

# READ THIS FIRST

## Model W1865

### \*\*\*IMPORTANT UPDATE\*\*\*

Applies to Models Mfd. Since 07/22  
and Owner's Manual Revised 07/19



Phone #: (360) 734-3482 • Tech Support: techsupport@woodstockint.com • Web: www.woodstockint.com

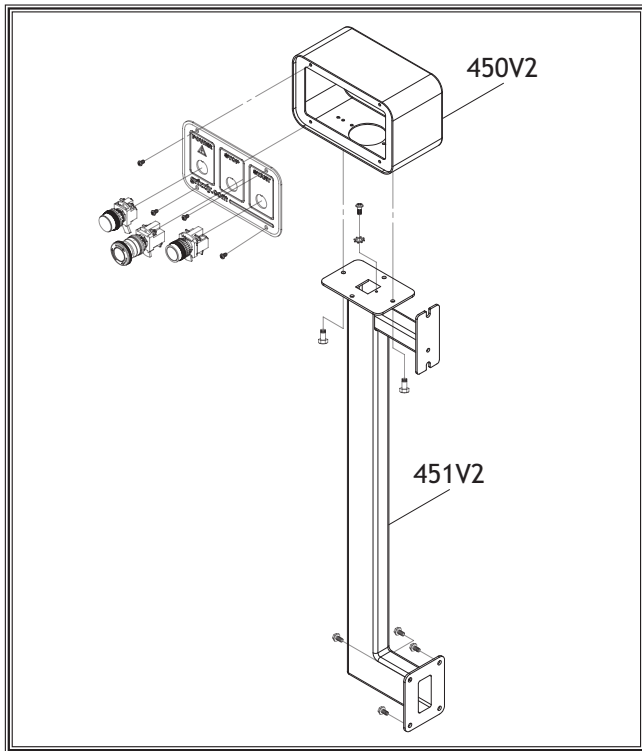
We made the following changes to this machine since the manual was printed:

- Switch box and pedestal have been modified.
- An additional step has been included in **Assembly**.

Aside from the information contained in this update, all other content in the owner's manual is applicable and **MUST** be read and understood for your own safety.

**IMPORTANT:** Keep this update with the owner's manual for future reference. If you have any further questions, contact our Technical Support.

### Revised Parts



### Revised Assembly

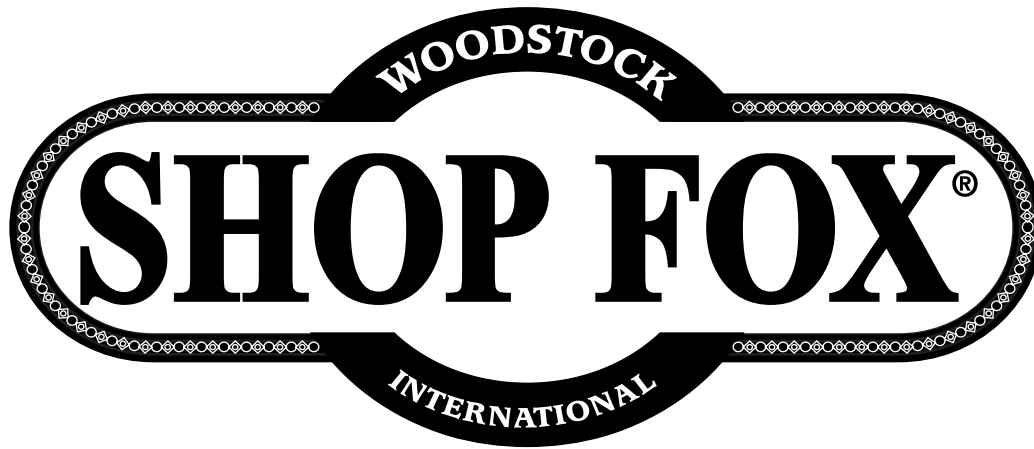
Please follow the **Assembly** instructions in the **Owner's Manual**, beginning on **Page 20**. Due to changes to the switch box and pedestal, the W1865 now requires an additional step.

10. **W1865:** Remove (2) M5-.8 x 10 hex bolts from base of switch box, and rotate box 90 degrees so control panel faces front of machine. Re-install switch box on pedestal using hex bolts.

REF	PART #	DESCRIPTION
450V2	X1865450V2	SWITCH BOX V2.07.22
451V2	X1865451V2	SWITCH PEDESTAL V2.07.22



**COPYRIGHT © JUNE, 2022 BY WOODSTOCK INTERNATIONAL, INC.**  
**WARNING: NO PORTION OF THIS MANUAL MAY BE REPRODUCED IN ANY SHAPE OR FORM WITHOUT**  
**THE WRITTEN APPROVAL OF WOODSTOCK INTERNATIONAL, INC. #22386MN PRINTED IN TAIWAN**



## MODEL W1864 & W1865 20" PLANERS



# OWNER'S MANUAL

*(FOR MODELS MANUFACTURED SINCE 07/19)*

Phone: (360) 734-3482 • Online Technical Support: [techsupport@woodstockint.com](mailto:techsupport@woodstockint.com)



COPYRIGHT © DECEMBER, 2018 BY WOODSTOCK INTERNATIONAL, INC. REVISED JULY, 2019 (JL).

WARNING: NO PORTION OF THIS MANUAL MAY BE REPRODUCED IN ANY SHAPE OR FORM WITHOUT

THE WRITTEN APPROVAL OF WOODSTOCK INTERNATIONAL, INC.

#WK20085 Printed in Taiwan



## **WARNING!**

This manual provides critical safety instructions on the proper setup, operation, maintenance, and service of this machine/tool. Save this document, refer to it often, and use it to instruct other operators.

Failure to read, understand and follow the instructions in this manual may result in fire or serious personal injury—including amputation, electrocution, or death.

The owner of this machine/tool is solely responsible for its safe use. This responsibility includes but is not limited to proper installation in a safe environment, personnel training and usage authorization, proper inspection and maintenance, manual availability and comprehension, application of safety devices, cutting/sanding/grinding tool integrity, and the usage of personal protective equipment.

The manufacturer will not be held liable for injury or property damage from negligence, improper training, machine modifications or misuse.



## **WARNING!**

Some dust created by power sanding, sawing, grinding, drilling, and other construction activities contains chemicals known to the State of California to cause cancer, birth defects or other reproductive harm. Some examples of these chemicals are:

- Lead from lead-based paints.
- Crystalline silica from bricks, cement and other masonry products.
- Arsenic and chromium from chemically-treated lumber.

Your risk from these exposures varies, depending on how often you do this type of work. To reduce your exposure to these chemicals: Work in a well ventilated area, and work with approved safety equipment, such as those dust masks that are specially designed to filter out microscopic particles.

# Contents

<b>INTRODUCTION</b> .....	<b>2</b>	<b>ACCESSORIES</b> .....	<b>36</b>
Machine Description .....	2	Planer Accessories .....	36
Woodstock Technical Support .....	2	<b>MAINTENANCE</b> .....	<b>38</b>
W1864 Machine Specifications .....	3	Schedule .....	38
W1865 Machine Specifications .....	5	Cleaning & Protecting .....	38
Identification .....	7	Lubrication .....	38
Controls & Components .....	8	<b>SERVICE</b> .....	<b>41</b>
Internal Components .....	9	General .....	41
<b>SAFETY</b> .....	<b>10</b>	Tensioning/Replacing V-Belts.....	41
Standard Machinery Safety Instructions ....	10	Checking/Adjusting Pulley Alignment.....	42
Additional Safety for Planers.....	12	Setting Feed Roller, Chip Breaker &	
<b>ELECTRICAL</b> .....	<b>13</b>	Pressure Bar Heights.....	43
Circuit Requirements .....	13	Adjusting Feed Roller Spring Tension .....	47
Grounding Requirements.....	14	Positioning Chip Deflector .....	48
Extension Cords .....	14	Calibrating Table Elevation Scale.....	49
<b>SETUP</b> .....	<b>15</b>	Checking Anti-Kickback Fingers.....	49
Unpacking .....	15	Tensioning Table Height Chain .....	50
Items Needed for Setup.....	15	Adjusting Table Parallelism .....	51
Inventory .....	16	Troubleshooting.....	53
Cleaning Machine.....	17	Electrical Safety Instructions.....	55
Machine Placement .....	18	W1864 Wiring Diagram .....	56
Lifting & Moving.....	19	W1864 Electrical Components .....	57
Assembly.....	20	W1865 Wiring Diagram .....	58
Dust Collection .....	21	W1865 Electrical Components .....	59
Checking Gearbox Oil Level .....	22	<b>PARTS</b> .....	<b>60</b>
Test Run.....	23	Main .....	60
Recommended Adjustments .....	24	W1864 Stand & Motor .....	63
<b>OPERATIONS</b> .....	<b>25</b>	W1865 Stand & Motor .....	65
Operation Overview .....	25	Table & Base .....	67
Workpiece Inspection.....	26	W1864 Labels & Cosmetics .....	69
Wood Types.....	26	W1865 Labels & Cosmetics .....	70
Planing Tips .....	27	<b>WARRANTY</b> .....	<b>73</b>
Cutting Problems .....	27		
Depth of Cut .....	29		
Bed Roller Height .....	29		
Setting Feed Rate .....	31		
Adjusting/Replacing Knives (W1864).....	31		
Rotating/Replacing Cutterhead Inserts (W1865).....	34		





# INTRODUCTION

## Machine Description

Models W1864 and W1865 are CSA-certified, 5 HP, 20" planers with the following differences:

- **Model W1864** has a 4-knife cutterhead and magnetic ON/OFF switch mounted to the headstock.
- **Model W1865** has a helical cutterhead and pedestal-mounted control panel with magnetic ON/OFF switch.

## Woodstock Technical Support

This machine has been specially designed to provide many years of trouble-free service. Close attention to detail, ruggedly built parts and a rigid quality control program assure safe and reliable operation.

Woodstock International, Inc. is committed to customer satisfaction. Our intent with this manual is to include the basic information for safety, setup, operation, maintenance, and service of this product.

We stand behind our machines! In the event that questions arise about your machine, please contact Woodstock International Technical Support at (360) 734-3482 Ext. 2 or send e-mail to: [techsupport@woodstockint.com](mailto:techsupport@woodstockint.com). Our knowledgeable staff will help you troubleshoot problems and process warranty claims.

If you need the latest edition of this manual, you can download it from <http://www.woodstockint.com/manuals>.

If you have comments about this manual, please contact us at:

Woodstock International, Inc.  
Attn: Technical Documentation Manager  
P.O. Box 2309  
Bellingham, WA 98227  
Email: [manuals@woodstockint.com](mailto:manuals@woodstockint.com)



# MACHINE SPECIFICATIONS



© Woodstock International, Inc. • Phone: (800) 840-8420 • Web: www.shopfox.biz

## MODEL W1864 20" PLANER, 5HP

### Product Dimensions

Weight..... 702 lbs.  
 Width (side-to-side) x Depth (front-to-back) x Height..... 39 x 58 x 45 in.  
 Footprint (Length x Width)..... 27-1/2 x 23 in

### Shipping Dimensions

Type..... Wood Crate  
 Content..... Machine  
 Weight..... 816 lbs.  
 Length x Width x Height..... 38 x 30 x 46 in.  
 Must Ship Upright..... Yes

### Electrical

Power Requirement..... 220V, Single-Phase, 60 Hz  
 Full-Load Current Rating..... 23A  
 Minimum Circuit Size..... 30A  
 Connection Type..... Cord & Plug  
 Power Cord Included..... Yes  
 Power Cord Length..... 10 ft.  
 Power Cord Gauge..... 12 AWG  
 Plug Included..... Yes  
 Included Plug Type..... L6-30  
 Switch Type..... Magnetic Switch w/Thermal Overload Protection

### Motors

#### Main

Horsepower..... 5 HP  
 Phase..... Single-Phase  
 Amps..... 23A  
 Speed..... 3450 RPM  
 Type..... TEFC Capacitor-Start Induction  
 Power Transfer ..... Triple V-Belt Drive  
 Bearings..... Shielded & Permanently Lubricated  
 Centrifugal Switch/Contacts Type..... External



**Main Specifications**

**Main Specifications**

Max. Cut Width.....	20 in.
Min. Stock Length.....	7 in.
Min. Stock Thickness.....	1/4 in.
Max. Stock Thickness.....	8 in.
Number of Cuts Per Inch.....	83, 104
Number of Cuts Per Minute.....	20,000
Cutterhead Speed.....	5000 RPM
Planing Feed Rate.....	16, 28 FPM
Max. Cut Depth Planing Full Width.....	3/32 in.
Max. Cut Depth Planing 6-Inch Wide Board.....	1/8 in.

**Cutterhead Info**

Cutterhead Type.....	4 Knife
Cutterhead Diameter .....	3-1/4 in.
Number of Knives.....	4
Knife Type.....	HSS, Single-Sided, Solid
Knife Size Length.....	20 in.
Knife Size Width.....	1 in.
Knife Size Thickness.....	1/8 in.
Knife Adjustment.....	Springs or Jack Screws

**Table Info**

Table/Headstock Movement.....	8 in.
Table Bed Size Length.....	56 in.
Table Bed Size Width.....	20 in.
Table Bed Size Thickness.....	2-1/2 in.
Number of Bed Rollers.....	2
Floor-to-Table Height.....	28 - 36 in.

**Construction**

Table.....	Precision-Ground Cast Iron
Body.....	Cast Iron
Stand.....	Steel
Cutterhead Assembly.....	Steel
Infeed Roller.....	Serrated Steel
Outfeed Roller.....	Smooth Steel
Paint Type/Finish.....	Powder Coated

**Other**

Table/Headstock Locks.....	Yes
Measurement Scale.....	Inch & Metric
Number of Dust Ports.....	1
Dust Port Size.....	5 in.
Mobile Base.....	D2058A

**Other**

Country of Origin .....	Taiwan
Warranty .....	2 Years
Approximate Assembly & Setup Time .....	2 Hours
Serial Number Location .....	ID Label on Upper Cover
ISO 9001 Factory .....	Yes
Certified by a Nationally Recognized Testing Laboratory (NRTL) .....	Yes



# MACHINE SPECIFICATIONS



© Woodstock International, Inc. • Phone: (800) 840-8420 • Web: www.shopfox.biz

## MODEL W1865 20" PLANER WITH HELICAL CUTTERHEAD, 5HP

### Product Dimensions

Weight..... 772 lbs.  
 Width (side-to-side) x Depth (front-to-back) x Height..... 44 x 56 x 45 in.  
 Footprint (Length x Width)..... 27-1/2 x 23 in.

### Shipping Dimensions

Type..... Wood Crate  
 Content..... Machine  
 Weight..... 882 lbs.  
 Length x Width x Height..... 45 x 30 x 46 in.  
 Must Ship Upright..... Yes

### Electrical

Power Requirement..... 220V, Single-Phase, 60 Hz  
 Prewired Voltage..... 220V  
 Full-Load Current Rating..... 23A  
 Minimum Circuit Size..... 30A  
 Connection Type..... Cord & Plug  
 Power Cord Included..... Yes  
 Power Cord Length..... 10 ft.  
 Power Cord Gauge..... 12 AWG  
 Plug Included..... Yes  
 Included Plug Type..... L6-30  
 Switch Type..... Button Controls w/Magnetic Switch Protection

### Motors

#### Main

Horsepower..... 5 HP  
 Phase..... Single-Phase  
 Amps..... 23A  
 Speed..... 3450 RPM  
 Type..... TEFC Capacitor-Start Induction  
 Power Transfer ..... Triple V-Belt Drive  
 Bearings..... Shielded & Permanently Lubricated  
 Centrifugal Switch/Contacts Type..... External





**Main Specifications**

**Main Specifications**

Planer Size.....	20 in.
Max. Cut Width.....	20 in.
Min. Stock Length.....	7 in.
Min. Stock Thickness.....	1/4 in.
Max. Stock Thickness.....	8 in.
Number of Cuts Per Inch.....	83, 104
Number of Cuts Per Minute.....	20,000
Cutterhead Speed.....	5000 RPM
Planing Feed Rate.....	16, 28 FPM
Max. Cut Depth Planing Full Width.....	5/64 in.
Max. Cut Depth Planing 6-Inch Wide Board.....	1/8 in.

**Cutterhead Info**

Cutterhead Type.....	Helical
Cutterhead Diameter .....	3-1/4 in.
Number of Cutter Spirals.....	4
Number of Indexable Cutters.....	92
Cutter Insert Size Length.....	15 mm
Cutter Insert Size Width.....	15 mm
Cutter Insert Size Thickness.....	2.5 mm

**Table Info**

Table/Headstock Movement.....	8 in.
Table Bed Size Length.....	56 in.
Table Bed Size Width.....	20 in.
Table Bed Size Thickness.....	2-1/4 in.
Number of Bed Rollers.....	2
Floor-to-Table Height.....	28 - 36 in.

**Construction**

Table.....	Precision-Ground Cast Iron
Body.....	Cast Iron
Stand.....	Steel
Cutterhead Assembly.....	Steel
Infeed Roller.....	Serrated Steel
Outfeed Roller.....	Smooth Steel
Paint Type/Finish.....	Powder Coated

**Other**

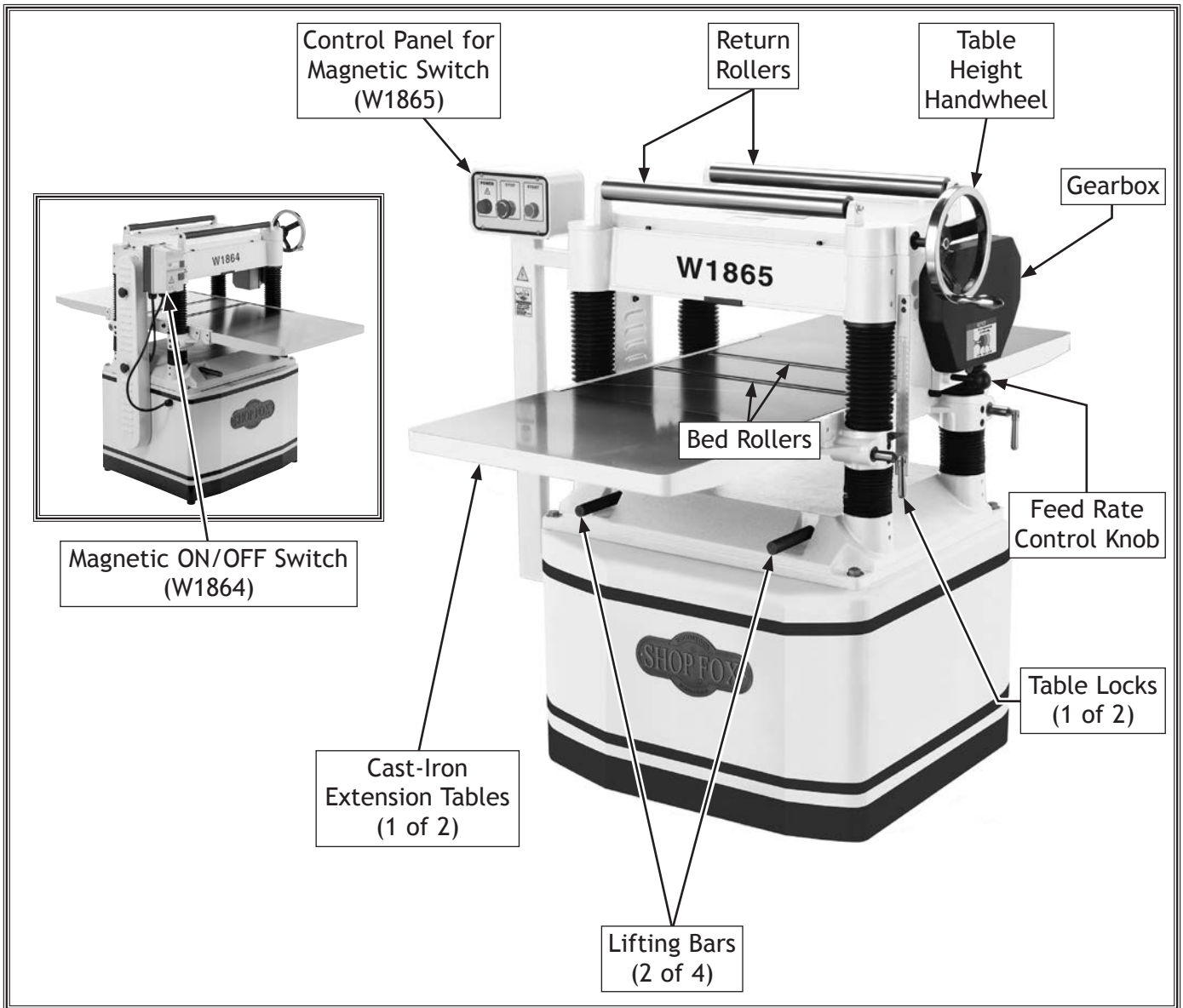
Table/Headstock Locks.....	Yes
Measurement Scale.....	Inch & Metric
Number of Dust Ports.....	1
Dust Port Size.....	5 in.
Mobile Base.....	D2058A

**Other**


Country of Origin .....	Taiwan
Warranty .....	2 Years
Approximate Assembly & Setup Time .....	2 Hours
Serial Number Location .....	ID Label on Upper Cover
ISO 9001 Factory .....	Yes
Certified by a Nationally Recognized Testing Laboratory (NRTL) .....	Yes

# Identification

Become familiar with the names and locations of the controls and features shown below to better understand the instructions in this manual.



**⚠ WARNING**



To reduce your risk of serious injury or damage to the machine, read this entire manual **BEFORE** using machine.

# Controls & Components

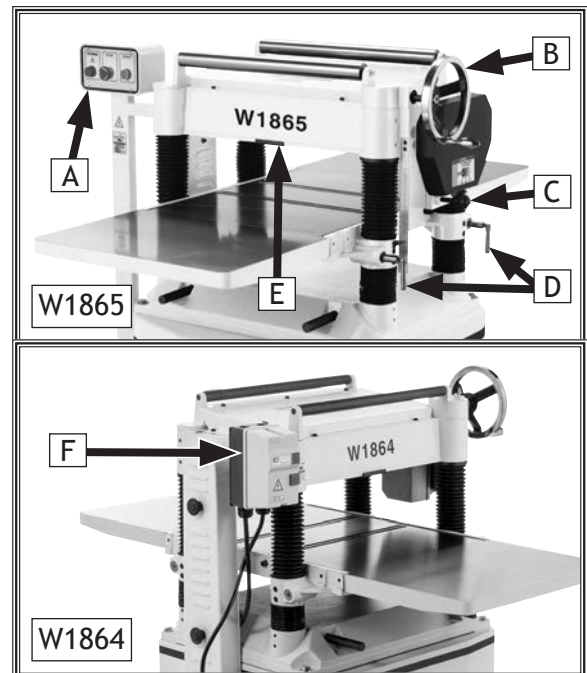
Refer to the **Figures 1-2** and the following descriptions to become familiar with the basic controls and components of this machine. Understanding these items and how they work will help you understand the rest of the manual and stay safe when operating this machine.

- A. Control Panel for Magnetic Switch (W1865):**
- Green START button turns motor **ON**.
  - Power indicator light illuminates when motor is turned **ON**.
  - Red STOP button turns motor **OFF**; for safety purposes, this button remains depressed and prevents restarting until reset. Reset by rotating clockwise until it pops out.
- B. Table Height Handwheel:** Raises and lowers table to accommodate different workpiece thicknesses. One complete revolution of handwheel moves the table approximately  $\frac{1}{16}$ ".
- C. Feed Rate Control Knob:** Selects 28 FPM feed rate when pushed in and 16 FPM feed rate when pulled out.
- D. Table Locks:** Secure table height position so they don't shift during cutting operation.
- E. Depth Limiter:** Limits depth of cut to a maximum of  $\frac{1}{8}$ " at full width.
- F. Magnetic ON/OFF Switch (W1864):**
- Green START button turns motor **ON**.
  - Red STOP button turns motor **OFF**; for safety purposes, this button remains depressed and prevents restarting until reset. Reset by rotating clockwise until it pops out.
- G. Return Rollers:** Assist sliding workpiece back to operator following planing operation.
- H. Dust Port:** 5" dust port connects to a dust-collection system to extract shavings and dust during operation.

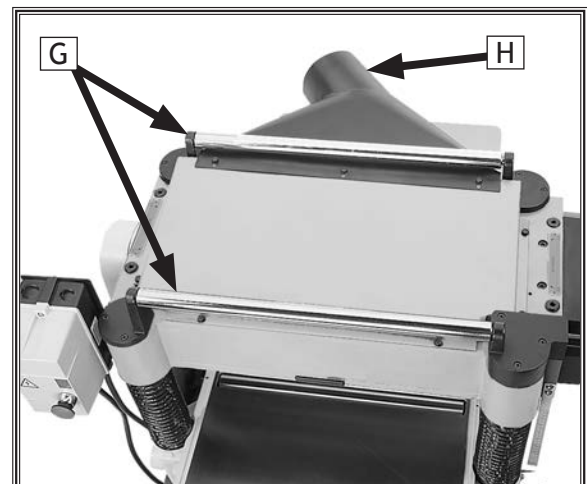
## ⚠ WARNING



To reduce your risk of serious injury or damage to the machine, read this entire manual **BEFORE** using machine.



**Figure 1.** Table elevation and feed controls.



**Figure 2.** Example of return rollers and dust port.

# Internal Components

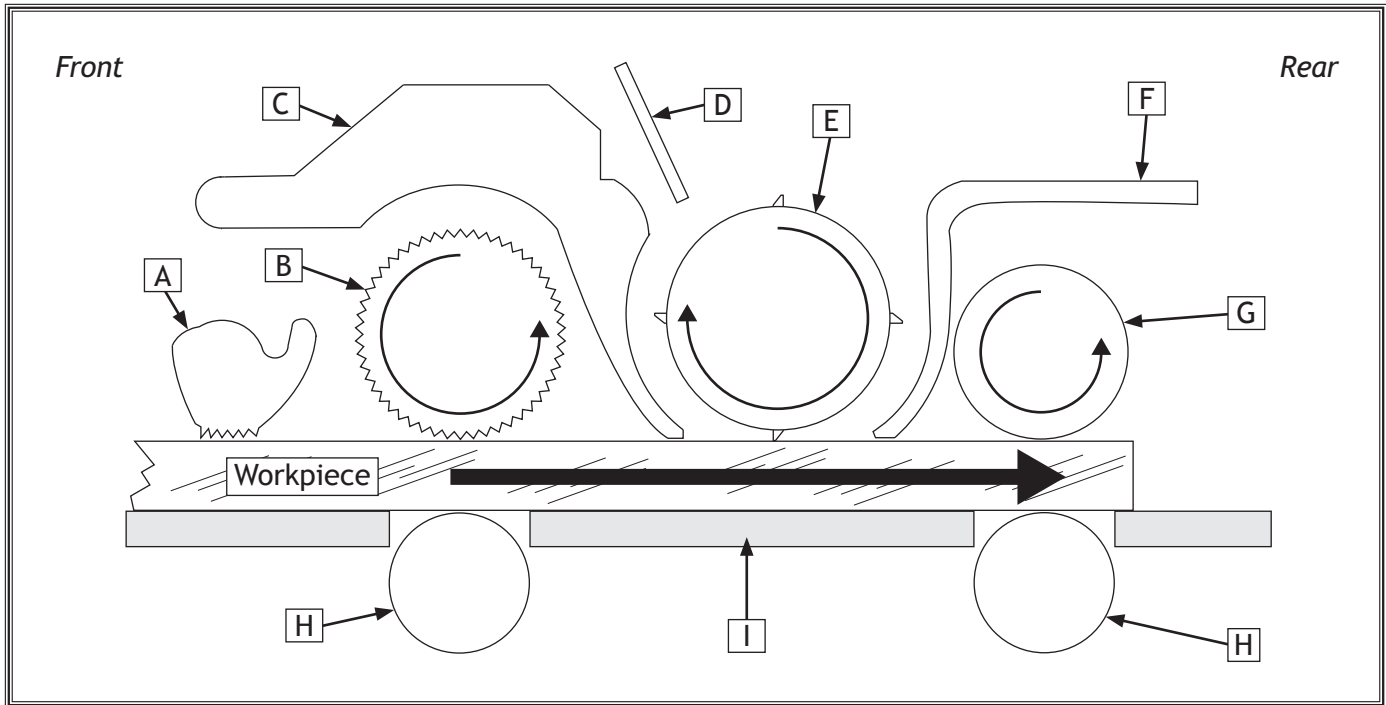


Figure 3. Workpiece path and major planing components (side cutaway view).

- A. **Anti-Kickback Fingers:** Provide additional safety for the operator.
- B. **Serrated Infeed Roller:** Pulls the workpiece toward the cutterhead.
- C. **Chip Breaker:** Breaks off chips created by the cutterhead to prevent tear-out and diverts the chips to the dust hood.
- D. **Chip Deflector:** Directs chips into the dust hood.
- E. **Cutterhead:** Holds the knives/indexable carbide inserts that remove material from the workpiece.
- F. **Pressure Bar:** Stabilizes the workpiece as it leaves the cutterhead and assists in deflecting wood particles toward the dust hood.
- G. **Outfeed Roller:** Pulls the workpiece through the planer.
- H. **Bed Rollers:** Provide upward pressure on the workpiece, enabling the feed rollers to pull the workpiece along.
- I. **Planer Table:** Provides a smooth and level path for the workpiece as it moves through the planer.

## WARNING

Like all machinery there is potential danger when operating this machine. Accidents are frequently caused by lack of familiarity or failure to pay attention. Use this machine with respect and caution to decrease the risk of operator injury. If normal safety precautions are overlooked or ignored, serious personal injury may occur.

# SAFETY

## For Your Own Safety, Read Manual Before Operating Machine

The purpose of safety symbols is to attract your attention to possible hazardous conditions. This manual uses a series of symbols and signal words intended to convey the level of importance of the safety messages. The progression of symbols is described below. Remember that safety messages by themselves do not eliminate danger and are not a substitute for proper accident prevention measures—this responsibility is ultimately up to the operator!



Indicates an imminently hazardous situation which, if not avoided, **WILL** result in death or serious injury.



Indicates a potentially hazardous situation which, if not avoided, **COULD** result in death or serious injury.



Indicates a potentially hazardous situation which, if not avoided, **MAY** result in minor or moderate injury.

### **NOTICE**

This symbol is used to alert the user to useful information about proper operation of the equipment or a situation that may cause damage to the machinery.

## Standard Machinery Safety Instructions

**OWNER'S MANUAL.** Read and understand this owner's manual **BEFORE** using machine.

**TRAINED OPERATORS ONLY.** Untrained operators have a higher risk of being hurt or killed. Only allow trained/supervised people to use this machine. When machine is not being used, disconnect power, remove switch keys, or lock-out machine to prevent unauthorized use—especially around children. Make workshop kid proof!

**DANGEROUS ENVIRONMENTS.** Do not use machinery in areas that are wet, cluttered, or have poor lighting. Operating machinery in these areas greatly increases the risk of accidents and injury.

**MENTAL ALERTNESS REQUIRED.** Full mental alertness is required for safe operation of machinery. Never operate under the influence of drugs or alcohol, when tired, or when distracted.

**ELECTRICAL EQUIPMENT INJURY RISKS.** You can be shocked, burned, or killed by touching live electrical components or improperly grounded machinery. To reduce this risk, only allow an electrician or qualified service personnel to do electrical installation or repair work, and always disconnect power before accessing or exposing electrical equipment.

**DISCONNECT POWER FIRST.** Always disconnect machine from power supply **BEFORE** making adjustments, changing tooling, or servicing machine. This eliminates the risk of injury from unintended startup or contact with live electrical components.

**EYE PROTECTION.** Always wear ANSI-approved safety glasses or a face shield when operating or observing machinery to reduce the risk of eye injury or blindness from flying particles. Everyday eyeglasses are not approved safety glasses.

**WEARING PROPER APPAREL.** Do not wear clothing, apparel, or jewelry that can become entangled in moving parts. Always tie back or cover long hair. Wear non-slip footwear to avoid accidental slips, which could cause loss of workpiece control.

**HAZARDOUS DUST.** Dust created while using machinery may cause cancer, birth defects, or long-term respiratory damage. Be aware of dust hazards associated with each workpiece material, and always wear a NIOSH-approved respirator to reduce your risk.

**HEARING PROTECTION.** Always wear hearing protection when operating or observing loud machinery. Extended exposure to this noise without hearing protection can cause permanent hearing loss.

**REMOVE ADJUSTING TOOLS.** Tools left on machinery can become dangerous projectiles upon startup. Never leave chuck keys, wrenches, or any other tools on machine. Always verify removal before starting!

**INTENDED USAGE.** Only use machine for its intended purpose—never make modifications without prior approval from Woodstock International. Modifying machine or using it differently than intended will void the warranty and may result in malfunction or mechanical failure that leads to serious personal injury or death!

**AWKWARD POSITIONS.** Keep proper footing and balance at all times when operating machine. Do not overreach! Avoid awkward hand positions that make workpiece control difficult or increase the risk of accidental injury.

**CHILDREN & BYSTANDERS.** Keep children and bystanders at a safe distance from the work area. Stop using machine if they become a distraction.

**GUARDS & COVERS.** Guards and covers reduce accidental contact with moving parts or flying debris—make sure they are properly installed, undamaged, and working correctly.

**FORCING MACHINERY.** Do not force machine. It will do the job safer and better at the rate for which it was designed.

**NEVER STAND ON MACHINE.** Serious injury may occur if machine is tipped or if the cutting tool is unintentionally contacted.

**STABLE MACHINE.** Unexpected movement during operation greatly increases risk of injury or loss of control. Before starting, verify machine is stable and mobile base (if used) is locked.

**USE RECOMMENDED ACCESSORIES.** Consult this owner's manual or the manufacturer for recommended accessories. Using improper accessories will increase risk of serious injury.

**UNATTENDED OPERATION.** To reduce the risk of accidental injury, turn machine **OFF** and ensure all moving parts completely stop before walking away. Never leave machine running while unattended.

**MAINTAIN WITH CARE.** Follow all maintenance instructions and lubrication schedules to keep machine in good working condition. A machine that is improperly maintained could malfunction, leading to serious personal injury or death.

**CHECK DAMAGED PARTS.** Regularly inspect machine for any condition that may affect safe operation. Immediately repair or replace damaged or mis-adjusted parts before operating machine.

**MAINTAIN POWER CORDS.** When disconnecting cord-connected machines from power, grab and pull the plug—NOT the cord. Pulling the cord may damage the wires inside, resulting in a short. Do not handle cord/plug with wet hands. Avoid cord damage by keeping it away from heated surfaces, high traffic areas, harsh chemicals, and wet/damp locations.

**EXPERIENCING DIFFICULTIES.** If at any time you experience difficulties performing the intended operation, stop using the machine! Contact Technical Support at (360) 734-3482.



# Additional Safety for Planers

Amputation, serious cuts, entanglement, or death can occur from contact with rotating cutterhead or other moving parts! Flying chips can cause eye injuries or blindness. Workpieces or knives thrown by cutterhead can strike nearby operator or bystanders with deadly force. To reduce risk of these hazards, operator and bystanders **MUST** completely heed hazards and warnings below.

**KICKBACK.** Know how to reduce the risk of kickback and kickback-related injuries. “Kickback” occurs during operation when the workpiece is ejected from the machine at high speed. Kickback is commonly caused by poor workpiece selection, unsafe feeding techniques, or improper machine setup/maintenance. Kickback injuries typically occur as follows: (1) operator/bystanders are struck by the workpiece, resulting in impact injuries (i.e., blindness, broken bones, bruises, death); (2) operator’s hands are pulled into blade, resulting in amputation or severe lacerations.

**AVOID CONTACT WITH MOVING PARTS.** Never remove guards/covers or reach inside the planer during operation or while connected to power. You could be seriously injured if you accidentally touch the spinning cutterhead or get entangled in moving parts. If a workpiece becomes stuck or sawdust removal is necessary, turn planer **OFF** and disconnect power before clearing.

**DULL/DAMAGED KNIVES/INSERTS.** Only use sharp, undamaged knives/inserts. Dull or damaged knives/inserts increase the risk of kickback.

**INSPECTING STOCK.** To reduce the risk of kickback injuries or machine damage, thoroughly inspect and prepare the workpiece before cutting. Verify workpiece is free of nails, staples, loose knots or foreign material. Workpieces with minor warping should be jointed first or planed with the cupped side facing the table.

**BODY PLACEMENT.** Stand to one side of planer during the entire operation to avoid getting hit if kickback occurs.

**GRAIN DIRECTION.** Planing across the grain is hard on the planer and may cause kickback. Plane in the same direction or at a slight angle with the wood grain.

**PLANING CORRECT MATERIAL.** Only plane natural wood stock with this planer. **DO NOT** plane MDF, OSB, plywood, laminates or other synthetic materials that can break up inside the planer and be ejected towards operator.

**LOOKING INSIDE PLANER.** Wood chips fly around inside the planer at a high rate of speed during operation. To avoid injury from flying material, **DO NOT** look inside planer during operation.

**CUTTING LIMITATIONS.** To reduce the risk of kickback hazards or damage to the machine, do not exceed the maximum depth of cut or minimum board length and thickness found in the **Data Sheet**. Only feed one board at a time.

**INFEEED ROLLER CLEARANCE.** The infeed roller is designed to pull material into the spinning cutterhead. To reduce the risk of entanglement, keep hands, clothing, jewelry, and long hair away from the infeed roller during operation.

**FEED WORKPIECE PROPERLY.** To reduce the risk of kickback, never start planer with workpiece touching cutterhead. Allow cutterhead to reach full speed before feeding, and do not change feed speed during cutting operation.

**WORKPIECE SUPPORT.** To reduce the risk of kickback, always make sure workpiece can move completely across table without rocking or tipping. Use auxiliary support stands for long stock.

**SECURE KNIVES/INSERTS.** Loose knives or improperly set inserts can become dangerous projectiles or cause machine damage. Always verify knives/inserts are secure and properly adjusted before operation.

# ELECTRICAL

## Circuit Requirements

This machine must be connected to the correct size and type of power supply circuit, or fire or electrical damage may occur. Read through this section to determine if an adequate power supply circuit is available. If a correct circuit is not available, a qualified electrician **MUST** install one before you can connect the machine to power.

A power supply circuit includes all electrical equipment between the breaker box or fuse panel in the building and the machine. The power supply circuit used for this machine must be sized to safely handle the full-load current drawn from the machine for an extended period of time. (If this machine is connected to a circuit protected by fuses, use a time delay fuse marked D.)

### Full-Load Current Rating

The full-load current rating is the amperage a machine draws at 100% of the rated output power. On machines with multiple motors, this is the amperage drawn by the largest motor or sum of all motors and electrical devices that might operate at one time during normal operations.

Full-Load Current Rating at 220V ..... 23 Amps

### Circuit Requirements


This machine is prewired to operate on a power supply circuit that has a verified ground and meets the following requirements:

- Nominal Voltage ..... 208V, 220V, 230V, 240V
- Cycle ..... 60 Hz
- Phase ..... 1-Phase
- Power Supply Circuit ..... 30 Amps
- Plug/Receptacle ..... NEMA L6-30
- Cord ..... "S"-Type, 3-Wire, 12 AWG, 300 VAC

**⚠ WARNING**

The machine must be properly set up before it is safe to operate. **DO NOT** connect this machine to the power source until instructed to do so later in this manual.

**⚠ WARNING**



Incorrectly wiring or grounding this machine can cause electrocution, fire, or machine damage. To reduce this risk, only an electrician or qualified service personnel should do any required electrical work on this machine.

**NOTICE**

The circuit requirements listed in this manual apply to a dedicated circuit—where only one machine will be running at a time. If this machine will be connected to a shared circuit where multiple machines will be running at the same time, consult with an electrician to ensure that the circuit is properly sized for safe operation.

ELECTRICAL



# Grounding Requirements

This machine **MUST** be grounded. In the event of certain types of malfunctions or breakdowns, grounding provides a path of least resistance for electric current to travel—in order to reduce the risk of electric shock.

Improper connection of the equipment-grounding wire will increase the risk of electric shock. The wire with green insulation (with/without yellow stripes) is the equipment-grounding wire. If repair or replacement of the power cord or plug is necessary, do not connect the equipment-grounding wire to a live (current carrying) terminal.

Check with a qualified electrician or service personnel if you do not understand these grounding requirements, or if you are in doubt about whether the tool is properly grounded. If you ever notice that a cord or plug is damaged or worn, disconnect it from power, and immediately replace it with a new one.

## For 220V Connection

This machine is equipped with a power cord that has an equipment-grounding wire and NEMA L6-30 grounding plug. The plug must only be inserted into a matching receptacle (see Figure) that is properly installed and grounded in accordance with local codes and ordinances.

## Extension Cords

We do not recommend using an extension cord with this machine. Extension cords cause voltage drop, which may damage electrical components and shorten motor life. Voltage drop increases with longer extension cords and smaller gauge sizes (higher gauge numbers indicate smaller sizes).

Any extension cord used with this machine must contain a ground wire, match the required plug and receptacle, and meet the following requirements:

- Minimum Gauge Size at 230V ..... 10 AWG
- Maximum Length (Shorter is Better) ..... 50 ft.

ELECTRICAL

**⚠ WARNING**

The machine must be properly set up before it is safe to operate. **DO NOT** connect this machine to the power source until instructed to do so later in this manual.

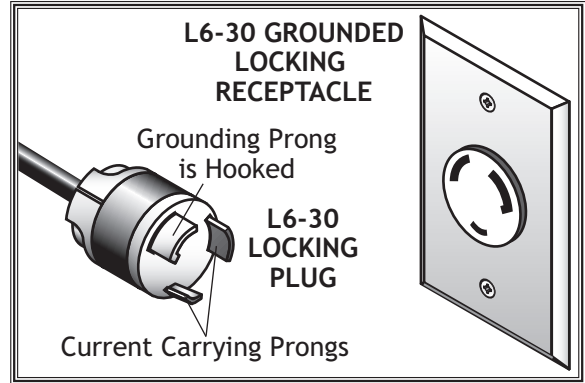


Figure 4. NEMA L6-30 plug & receptacle.

**⚠ CAUTION**

No adapter should be used with the required plug. If the plug does not fit the available receptacle or the machine must be reconnected to a different type of circuit, the reconnection must be made by an electrician or qualified service personnel and it must comply with all local codes and ordinances.

# SETUP

## Unpacking

This machine has been carefully packaged for safe transportation. If you notice the machine has been damaged during shipping, please contact your authorized Shop Fox dealer immediately.

## Items Needed for Setup

The following items are needed, but not included, to set up your machine.


Description	Qty
• Additional People.....	1
• Safety Glasses.....	1 Per Person
• Forklift (rated for at least 1000 lbs.).....	1
• Cleaner/Degreaser.....	As Needed
• Disposable Shop Rags.....	As Needed
• Phillips Screwdriver #2.....	1
• Hex Wrench 6mm.....	1
• Wrench or Socket 18mm.....	1
• Straightedge 4'.....	1
• Dust-Collection System.....	1
• 5" Dust Hose.....	Length As Needed
• 5" Hose Clamps.....	2

### W1864 Only:

- Wrench or Socket 10mm, 16mm..... 1 Ea.

### W1865 Only:

- Wrench or Socket 13mm..... 1




### ⚠ WARNING

This machine presents serious injury hazards to untrained users. Read through this entire manual to become familiar with the controls and operations before starting the machine!



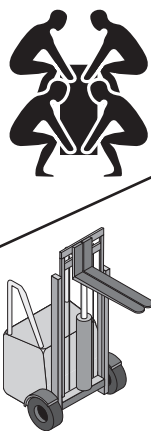
### ⚠ WARNING

Wear safety glasses during entire setup process!



### ⚠ WARNING

**SUFFOCATION HAZARD!**  
Immediately discard all plastic bags and packing materials to eliminate choking/suffocation hazards for children and animals.



### ⚠ WARNING

**HEAVY LIFT!**  
Straining or crushing injury may occur from improperly lifting the machine or some of its parts. To reduce this risk, get help from other people and use a forklift (or other lifting equipment) rated for weight of machine.

SETUP

# Inventory

The following is a list of items shipped with your machine. Before beginning setup, lay these items out and inventory them.

**Note:** If you cannot find an item on this list, carefully check around/inside the machine and packaging materials. Often, these items get lost in packaging materials while unpacking or they are pre-installed at the factory.

Box 1 (Figure 5)	Qty
A. Planer Unit (Not Shown).....	1
B. Cast-Iron Extension Wings.....	2
C. Table Height Handwheel .....	1
D. Dust Hood.....	1

## Tools and Hardware (Figure 6)

E. Hex Wrenches 3, 4, 5, 6mm .....	1 Ea.
F. Flat Washer 13mm (Handwheel) .....	1
G. Flange Bolts M6-1 x 12 (Dust Hood) .....	6
H. Hex Bolts M8-1.25 x 25 (Ext. Tables).....	6
I. Flat Washers 8mm (Ext. Tables).....	6
J. Set Screws M8-1.25 x 12 (Ext. Tables) .....	6
K. Handwheel Handle (Handwheel).....	1
L. Hex Nut M12-1.75 (Handwheel) .....	1
M. Key 4 x 4 x 10 (Handwheel).....	1
N. LOW/HIGH Direction Label (Handwheel) .....	1
O. Flat Wrench 10/13mm.....	1
P. Open-End Wrenches 8/10, 12/14, 17/19mm.....	1 Ea.

## W1864 Only (Figure 7)

Q. Knife-Setting Jig Assembly .....	1
– Knife-Setting Jig Foot .....	2
– Knife-Setting Jig Shaft .....	1
– E-Clip 9mm .....	4

## W1865 Only (Figure 8)

R. T-Handle Torx Wrenches T-25.....	2
S. Flat Head Torx Screws #10-32 x 1/2" .....	20
T. Indexable Carbide Inserts 15 x 15 x 2.5 .....	10

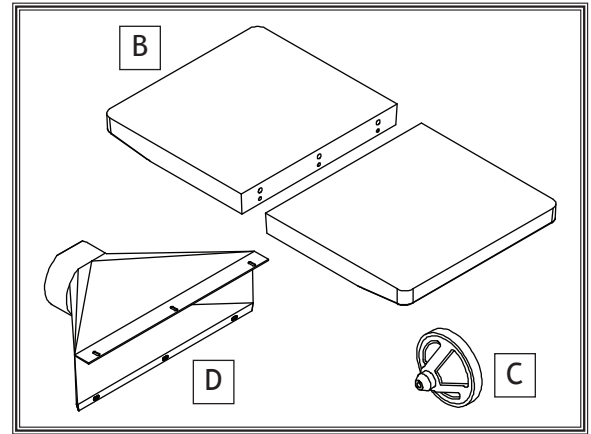


Figure 5. Box inventory.

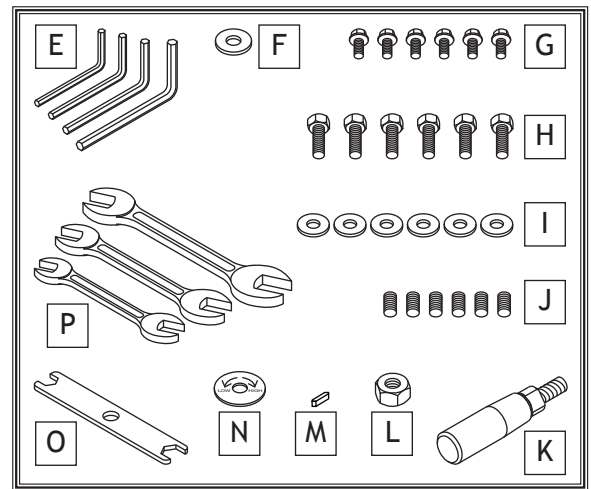


Figure 6. Tools and hardware.

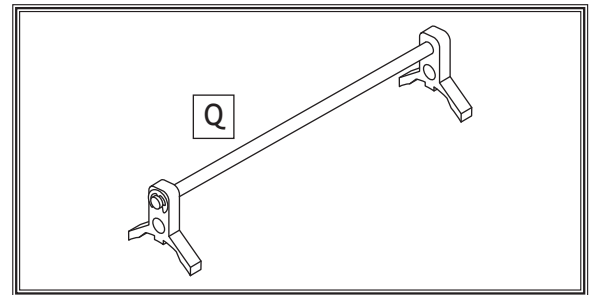


Figure 7. Knife-setting jig assembly (W1864 only).

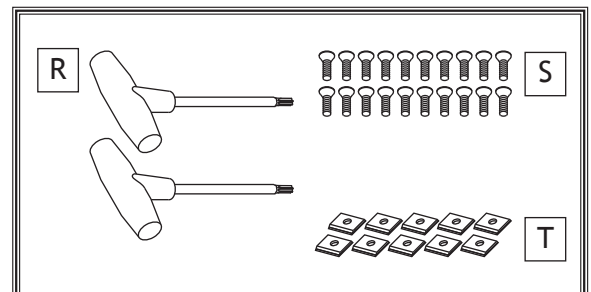


Figure 8. Tools and hardware (W1865 only).

# Cleaning Machine

To prevent corrosion during shipment and storage of your machine, the factory has coated the bare metal surfaces of your machine with a heavy-duty rust prevention compound.

If you are unprepared or impatient, this compound can be difficult to remove. To ensure that the removal of this coating is as easy as possible, please gather the correct cleaner, lubricant, and tools listed below:

- Cleaner/degreaser designed to remove storage wax and grease
- Safety glasses & disposable gloves
- Solvent brush or paint brush
- Disposable Rags

To remove rust preventative coating, do these steps:

1. DISCONNECT MACHINE FROM POWER!
2. Put on safety glasses and disposable gloves.
3. Coat the rust preventative with a liberal amount of cleaner/degreaser, then let it soak for 5-10 minutes.
4. Wipe off surfaces. If your cleaner/degreaser is effective, the coating will wipe off easily.

**Tip:** *An easier way to clean off thick coats of rust preventative from flat surfaces is to use a PLASTIC paint scraper to scrape off the majority of the coating before wiping it off with your rag. (Do not use a metal scraper or you may scratch your machine.)*

5. Repeat cleaning steps as necessary until all of the compound is removed.
6. To prevent rust on freshly cleaned surfaces, immediately coat with a quality metal protectant.

<b>! WARNING</b>	
	<p>Gasoline and petroleum products have low flash points and can explode or cause fire if used to clean machinery. Avoid using these products to clean machinery. Many cleaning solvents are toxic if inhaled. Minimize your risk by only using these products in a well ventilated area.</p>

<b>NOTICE</b>
<p>In a pinch, automotive degreasers, mineral spirits or WD•40 can be used to remove rust preventative coating. Before using these products, though, test them on an inconspicuous area of your paint to make sure they will not damage it.</p>

SETUP

# Machine Placement

## Weight Load

Refer to the **Machine Specifications** for the weight of your machine. Make sure that the surface upon which the machine is placed will bear the weight of the machine, additional equipment that may be installed on the machine, and the heaviest workpiece that will be used. Additionally, consider the weight of the operator and any dynamic loading that may occur when operating the machine.

## Space Allocation

Consider the largest size of workpiece that will be processed through this machine and provide enough space around the machine for adequate operator material handling or the installation of auxiliary equipment. With permanent installations, leave enough space around the machine to open or remove doors/covers as required by the maintenance and service described in this manual. **See below for required space allocation.**

## Physical Environment

The physical environment where your machine is operated is important for safe operation and the longevity of its components. For best results, operate this machine in a dry environment that is free from excessive moisture, hazardous chemicals, airborne abrasives, or extreme conditions. Extreme conditions for this type of machinery are generally those where the ambient temperature range exceeds 41°-104°F; the relative humidity range exceeds 20-95% (non-condensing); or the environment is subject to vibration, shocks, or bumps.

## Electrical Installation

Place this machine near an existing power source. Make sure all power cords are protected from traffic, material handling, moisture, chemicals, or other hazards. Make sure to leave access to a means of disconnecting the power source or engaging a lockout/tagout device.

## Lighting

Lighting around the machine must be adequate enough that operations can be performed safely. Shadows, glare, or strobe effects that may distract or impede the operator must be eliminated.

SETUP

	<h3>CAUTION</h3> <p>Children or untrained people may be seriously injured by this machine. Only install in an access restricted location.</p>
--	---

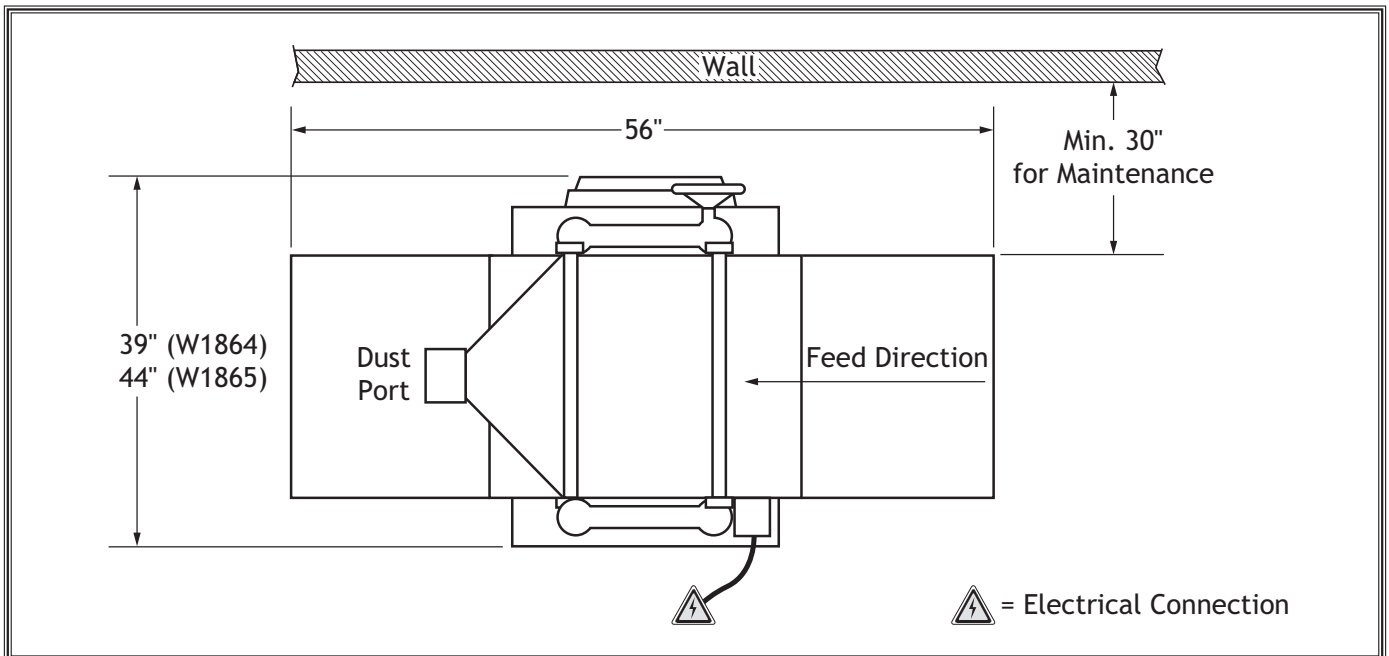



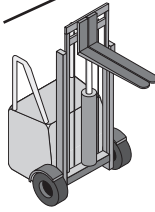
Figure 9. Working clearances.

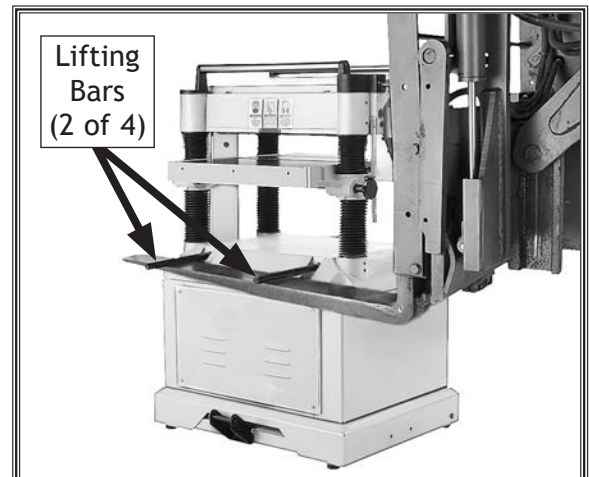
## Lifting & Moving

The planer is equipped with four lifting bars that extend in order to lift and place the planer.

To lift and place the planer, extend the lifting bars and use a forklift to lift the machine off the pallet, as shown in **Figure 10**, then set the planer down in a suitable location and return the lifting bars to their original position.

**Tip:** When positioning lift forks, place shop rags or cardboard between forks and cabinet stand to avoid scratching paint.

	<p><b>⚠ WARNING</b> <b>HEAVY LIFT!</b> Straining or crushing injury may occur from improperly lifting the machine or some of its parts. To reduce this risk, get help from other people and use a forklift (or other lifting equipment) rated for weight of machine.</p>
	



**Figure 10.** Example of lifting planer with forklift.

SETUP



# Assembly

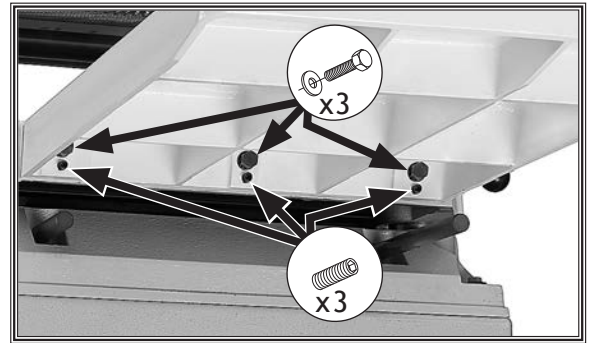
Before beginning the assembly process, refer to **Items Needed for Setup** and gather everything you need. Ensure all parts have been properly cleaned of any heavy-duty rust-preventative applied at the factory (if applicable). Be sure to complete all steps in the assembly procedure prior to performing the **Test Run** or connecting

To assemble planer, do these steps:

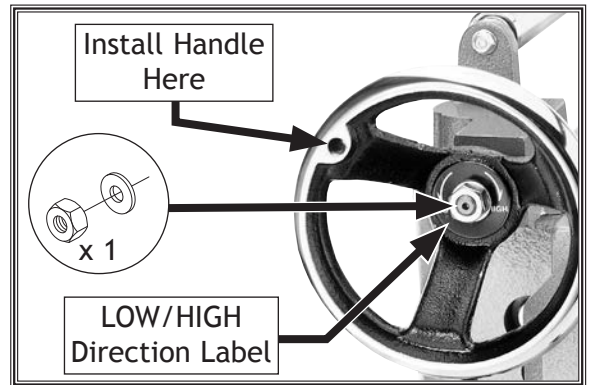
1. Attach each cast-iron extension wing to planer table with (3) M8-1.25 x 25 hex bolts and (3) 8mm flat washers (see **Figure 11**). Do not tighten hex bolts at this time.
2. Thread (3) M8-1.25 x 20 set screws into each extension wing at locations shown in **Figure 11**.
3. Using a straightedge as a guide, rotate set screws from **Step 2** until extension wings are in plane with main table, then fully tighten hex bolts from **Step 1**.

**Note:** *Bed rollers will give you a false reading with your straightedge if they are raised above table. Move them down or work around them when leveling extension wings (refer to **Bed Roller Height** on **Page 29** for details).*

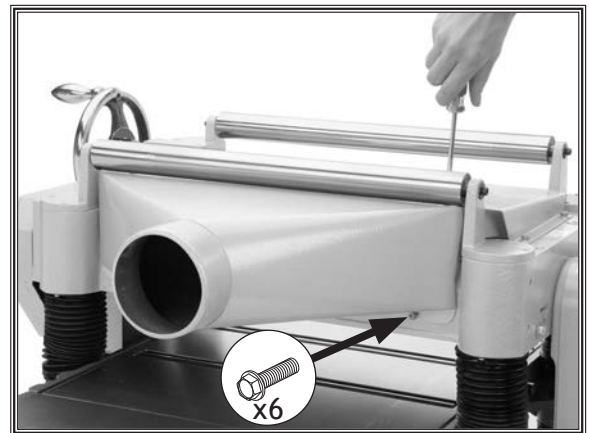
4. Insert key into keyway on handwheel shaft on top of planer.
5. Line up notch in handwheel bore with key, then slide handwheel onto shaft (see **Figure 12**).
6. Slide LOW/HIGH direction label onto handwheel shaft, and secure handwheel with 13mm flat washer and M12-1.75 hex nut (see **Figure 12**).
7. Thread handwheel handle into handwheel (see **Figure 12**) and tighten with wrench.
8. Attach dust hood to planer with (6) M6-1 x 12 flange bolts (see **Figure 13**).



**Figure 11.** Extension wing mounting locations.



**Figure 12.** Table elevation handwheel installed.



**Figure 13.** Dust port installed.

SETUP

- 9. **W1864:** Assemble knife-setting jig (see **Figure 14**).
  - a. Snap (2) 9mm E-clips into inner notches on knife-setting jig shaft.
  - b. Slide (2) knife-setting jig feet onto ends of shaft.
  - c. Snap (2) 9mm E-clips into outer notches on ends of shaft to secure feet.

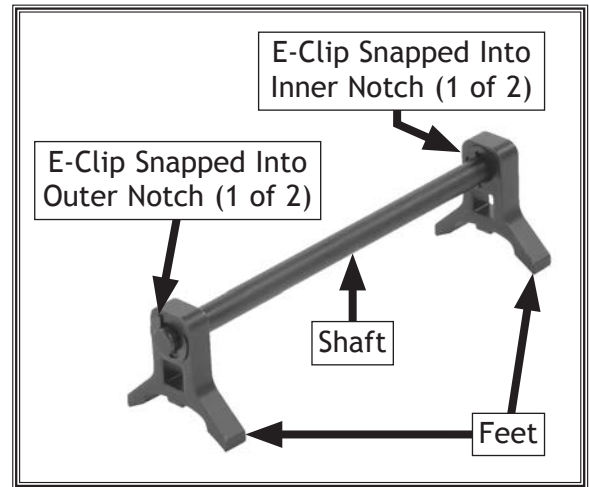


Figure 14. Example of assembled knife-setting jig components.

## Dust Collection

Recommended CFM at Dust Port: ..... 600 CFM

Do not confuse this CFM recommendation with the rating of the dust collector. To determine the CFM at the dust port, you must consider these variables: (1) CFM rating of the dust collector, (2) hose type and length between the dust collector and the machine, (3) number of branches or wyes, and (4) amount of other open lines throughout the system. Explaining how to calculate these variables is beyond the scope of this manual. Consult an expert or purchase a good dust collection “how-to” book.

### CAUTION

This machine creates substantial amounts of dust during operation. Breathing airborne dust on a regular basis can result in permanent respiratory illness. Reduce your risk by wearing a respirator and capturing the dust with a dust collection system.

To connect the machine to a dust-collection system, fit a 5" dust hose over the dust port, and secure in place with a hose clamp (see **Figure 15**). Tug the hose to make sure it does not come off.

**Note:** A tight fit is necessary for proper performance.

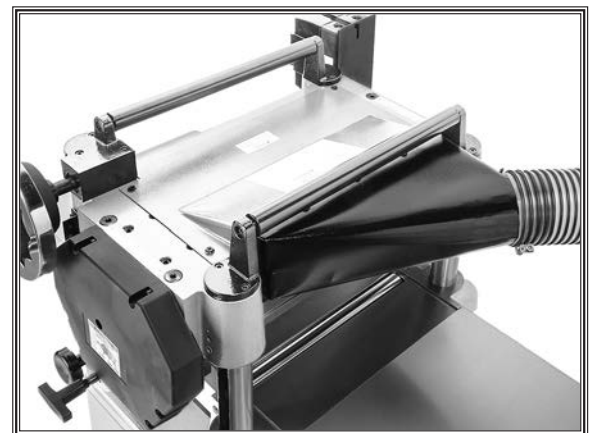


Figure 15. Example of dust hose connected to dust port.

SETUP



# Checking Gearbox Oil Level

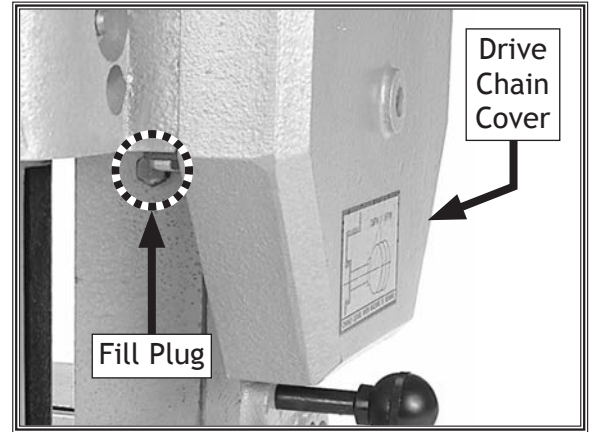
Before starting your machine for the first time, check the gearbox oil level. The proper oil level is just even with the bottom of the fill hole. The gearbox uses ISO 320 gear oil. However, SAE 140 gear oil or SAE 85W-140 multi-weight gear oil may also be used as alternatives. DO NOT mix oil types.

**Note:** For easier access to the fill plug, remove the drive chain cover (see **Figure 16**).

To check gearbox oil level, do these steps:

1. Remove gearbox fill plug (see **Figure 16**).
2. Wipe clean the 6mm hex wrench that came with your machine, dip the short end of it inside fill hole, and then remove it.
  - If the end of the hex wrench is coated with oil, then the gearbox oil level is okay. Replace the fill plug and continue setup.
  - If the end of the hex wrench is *not* coated with oil, then you need to add more oil. Refer to **Gearbox Oil on Page 40** for instructions on how to do this.

**Note:** We recommend that you replace the gearbox oil after the first 20 hours of operation. This is a normal break-in procedure and will help maximize the service life of the machine by flushing away any particles from the break-in and manufacturing process.



**Figure 16.** Location of gearbox fill plug.

# Test Run

Once assembly is complete, test run the machine to ensure it is properly connected to power and safety components are functioning properly.

If you find an unusual problem during the test run, immediately stop the machine, disconnect it from power, and fix the problem BEFORE operating the machine again. The **Troubleshooting** table in the **SERVICE** section of this manual can help.

The Test Run consists of verifying the following: 1) The motor powers up and runs correctly, and 2) the STOP/ reset button safety feature functions properly.

To test run machine, do these steps:

1. Clear all setup tools and loose objects away from machine.
2. **W1865 Only:** Push STOP button in.
3. Connect machine to power supply.
4. **W1865 Only:** Twist STOP button clockwise until it springs out (see **Figure 17**). This resets the switch so the machine can start.
5. Press START button to turn machine **ON**. Verify motor starts up and runs smoothly without any unusual problems or noises.
6. Press STOP button to turn machine **OFF**.
  - **W1864 only:** Congratulations! Test Run is complete.
7. **W1865 Only:** WITHOUT resetting STOP button, try to start machine by pressing the START button. The machine should not start.
  - If the machine does not start, the STOP button safety feature is working correctly. Congratulations! Test Run is complete.
  - If the machine does start with the STOP button pushed in, immediately disconnect power to the machine. The STOP button safety feature is not working correctly and must be replaced before further using the machine. Call Tech Support for help.

**⚠ WARNING**

Serious injury or death can result from using this machine BEFORE understanding its controls and related safety information. DO NOT operate, or allow others to operate, machine until the information is understood.

**⚠ WARNING**

DO NOT start machine until all preceding setup instructions have been performed. Operating an improperly set up machine may result in malfunction or unexpected results that can lead to serious injury, death, or machine/property damage.

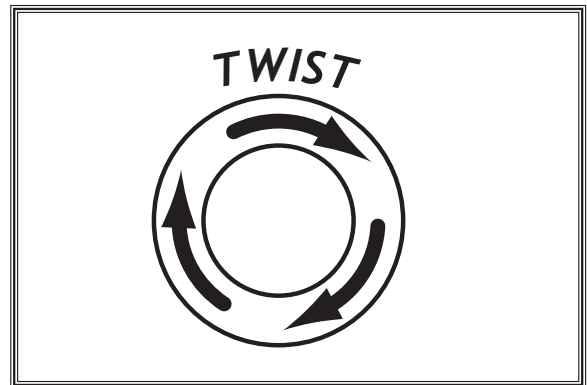


Figure 17. Resetting the switch.

# Recommended Adjustments

The adjustments listed below have been performed at the factory. However, because of the many variables involved with shipping, we recommend that you verify the adjustments to ensure the best possible results from your new machine.

Step-by-step instructions for these adjustments can be found in the **SERVICE** section starting on **Page 41**.

**Factory adjustments that should be verified:**

- Tensioning/replacing V-belts (**Page 41**).
- Calibrating table elevation scale (**Page 49**).
- Pulley alignment (**Page 42**).

## **NOTICE**

After approximately 16 hours of operation, V-belts will stretch and seat into pulley grooves and need to be properly tensioned to avoid severely reducing life of V-belts. Refer to Tensioning/Replacing V-Belts on Page 41 for detailed instructions.

# OPERATIONS

## Operation Overview

The purpose of this overview is to provide the novice machine operator with a basic understanding of how the machine is used during operation, so the machine controls/components discussed later in this manual are easier to understand.

Due to the generic nature of this overview, it is **not** intended to be an instructional guide. To learn more about specific operations, read this entire manual and seek additional training from experienced machine operators, and do additional research outside of this manual by reading "how-to" books, trade magazines, or websites.

To complete a typical operation, the operator does the following:

1. Examines workpiece to make sure it is suitable for planing.
2. Puts on safety glasses or face shield, a respirator, and hearing protection.
3. Places workpiece on table with flat side down and correctly adjusts table height for workpiece thickness and depth of cut.
  - If workpiece is bowed, operator surface planes workpiece on a jointer until one side is flat. Doing so ensures that it sits solidly on planer table during operation.
4. When all safety precautions have been taken, turns planer **ON**.
5. Stands to one side of planer path to reduce risk of kickback injuries, then feeds workpiece into planer until infeed roller grabs it.

**Note:** *Infeed and outfeed rollers control feed rate of workpiece as it passes through planer. Operator should not push or pull on workpiece.*

– If cut is too deep and bogs down planer, operator immediately reduces depth of cut.

**! WARNING**

To reduce your risk of serious injury or damage to the machine, read this entire manual **BEFORE** using machine.

**! WARNING**

Eye injuries, respiratory problems, or hearing loss can occur while operating this tool. Wear personal protective equipment to reduce your risk from these hazards.

**NOTICE**

If you are an inexperienced operator, we strongly recommend that you read books or trade articles, or seek training from an experienced operator of this type of machinery before performing unfamiliar operations. Above all, safety must come first!

6. Once workpiece is clear of outfeed roller and stops moving, operator removes workpiece from outfeed table and measures thickness. If further planing is required, operator raises table slightly ( $\frac{1}{4}$  to  $\frac{1}{2}$  turn of table height handwheel), then feeds workpiece into front of planer again.
7. Operator continues process until desired thickness is achieved, then turns machine **OFF**.

OPERATIONS

# Workpiece Inspection

Some workpieces are not safe to use or may require modification before they are. **Before cutting, inspect all workpieces for the following:**

- **Material Type:** This machine is only intended for workpieces of natural wood fiber. Attempting to use workpieces of any other material that may break apart during operation could lead to serious personal injury and property damage.
- **Foreign Objects:** Inspect lumber for defects and foreign objects (nails, staples, embedded gravel, etc.). If you have any question about the quality of your lumber, **DO NOT** use it. Remember, wood stacked on a concrete floor can have small pieces of stone or concrete pressed into the surface.
- **Large/Loose Knots:** Loose knots can become dislodged during operation. Large knots can cause kickback and machine damage. Always use workpieces that do not have large/loose knots.
- **Wet or "Green" Stock:** Avoid using wood with a high water content. Wood with more than 20% moisture content or wood exposed to excessive moisture (such as rain or snow), will cut poorly and cause excessive wear to the machine. Excess moisture can also hasten rust and corrosion of the machine and/or individual components.
- **Excessive Warping:** Workpieces with excessive cupping, bowing, or twisting are dangerous to cut because they are unstable and often unpredictable when being cut. **DO NOT** use workpieces with these characteristics!
- **Minor Cupping:** Workpieces with slight cupping can be safely supported if the cupped side is facing the table. On the contrary, a workpiece supported on the bowed side will rock during operation and could cause severe injury from kickback.

# Wood Types

The species of wood, as well as its condition, greatly affects the depth of cut the planer can effectively take with each pass.

The chart in the figure below shows the Janka Hardness Rating for a number of commonly used species. The larger the number, the harder the workpiece, and the less material should be removed in any one pass for good results.

**Note:** *The Janka Hardness Rating is expressed in pounds of force required to embed a 0.444" steel ball into the surface of the wood to a depth equal to half the ball's diameter.*

Species	Janka Hardness
Ebony	3220
Red Mahogany	2697
Rosewood	1780
Red Pine	1630
Sugar Maple	1450
White Oak	1360
White Ash	1320
American Beech	1300
Red Oak	1290
Black Walnut	1010
Teak	1000
Black Cherry	950
Cedar	900
Sycamore	770
Douglas Fir	660
Chestnut	540
Hemlock	500
White Pine	420
Basswood	410
Eastern White Pine	380
Balsa	100

**Figure 18.** Janka Hardness Rating for some common wood species.

## Planing Tips

- Inspect your lumber for twisting or cupping, and surface one face on a jointer if necessary before planing workpiece.
- Scrape off all glue when planing glued-up panels. Dried glue can quickly dull knives/inserts.
- DO NOT plane more than one piece at a time.
- Never remove more than the recommended amount of material on each pass. Only remove a small amount of material on each pass when planing wide or dense stock.
- Support the workpiece on both ends. Get assistance from another person if you are planing long lumber, or use roller stands to support the workpiece.
- Measure the workpiece thickness with calipers to get exact results.
- Carefully inspect all stock to make sure it is free of large knots or foreign objects that may damage your knives/inserts, cause kickback, or be ejected from the planer.
- When possible, plane equal amounts on each side of the board to reduce the chance of twisting or cupping.
- Use the entire width of the planer to wear knives/inserts evenly. With narrow workpieces, alternate between far left, far right, and the middle of the table. Your knives/inserts will remain sharp much longer.
- To avoid "chip marks," always plane WITH the grain direction of the wood. Never plane cross-grain or end-grain.
- Plane ONLY natural wood fiber. Do not plane wood composites or other materials that could break up in the planer and cause operator injury or damage to planer.
- Always true cupped or warped stock on a jointer before planing.

## Cutting Problems

Below is a list of wood characteristics you may encounter when planing. The following descriptions of defects will give you some possible answers to problems you may encounter while planing different materials. Possible solutions follow the descriptions.

### Chipped Grain

**Problem:** Usually a result of cutting against the grain, planing lumber with knots or excessive amount of cross grain, or using dull knives/inserts.

**Note:** *Some amount of chipping is normal with highly figured wood.*

**Solution:** Decrease the depth of cut. Reduce the feed rate. Inspect your lumber and determine if its grain pattern is causing the problem. If the lumber does not show substantial crossgrain, inspect your knives/inserts.

### Fuzzy Grain

**Problem:** Usually caused by surfacing lumber with too high of a moisture content. Sometimes fuzzy grain is an unavoidable characteristic of some woods, such as basswood. Fuzzy grain can also be caused by dull knives/inserts.

**Solution:** Check the lumber with a moisture meter. If moisture is greater than 20%, sticker the lumber and allow it to dry. Otherwise, inspect the knife/insert condition.

### Snipe

**Problem:** Occurs when board ends have more material removed than the rest of the board. Usually caused when the workpiece is not properly supported as it goes through the machine. In many cases, however, a small amount of snipe is inevitable.

**Solution:** Hold workpiece up slightly as it leaves the outfeed end of the planer. The best way to deal with snipe is by planing lumber longer than your intended work length and then cutting off the excess after planing is completed.



## Chip Marks or Indentations

**Problem:** Chip indentation or chip bruising is the result of wood chips not being ejected from the machine. Instead they are carried around the cutterhead, deposited on the planed surface and crushed by the outfeed roller. Some causes of chip indentation are:

- Wood chips/sawdust not being properly expelled from the cutterhead.
- The type of lumber being planed. Certain species have a tendency to chip bruise.
- High moisture content (over 20%) or surface moisture (refer to **Workpiece Inspection**).
- Dull knives/inserts.
- Excessive depth of cut.

### Solution:

- Use a proper dust-collection system; adjust chip deflector in or out as necessary.
- Lumber must be completely dry, preferably kiln-dried (KD). Air-dried (AD) lumber must be seasoned properly and have no surface moisture. **DO NOT** surface partially-air-dried (PAD) lumber.
- Make sure planer knives/inserts are sharp.
- Reduce depth of cut.

## Pitch & Glue Build-up

**Problem:** Glue/resin buildup on the rollers and cutterhead will cause overheating by decreasing cutting sharpness while increasing drag in the feed mechanism. This can result in scorched lumber, uneven knife/insert marks, and chatter.

**Solution:** Clean the rollers and cutterhead.

## Rippled Cut

**Problem:** Regularly spaced indentations across face of workpiece are caused by excessive outfeed roller pressure or excessive feed rate.

**Solution:** Reduce outfeed roller pressure; reduce feed rate.

# Depth of Cut

## Table Movement per Handwheel Revolution

One Full Revolution..... 1/16"

## Material Thickness Range

Minimum-Maximum Stock Thickness ..... 1/4"-8"

The depth of cut on a planer means the amount of material that is removed from the top of the workpiece as it passes underneath the cutterhead.

The depth of cut is set by adjusting the distance of the table below the cutterhead. This distance is the thickness of the workpiece minus the depth of cut. The planing depth of cut is controlled by using the table height handwheel on the right side of the machine. Rotating the handwheel clockwise raises the table.

Although the correct depth of cut varies according to wood hardness and workpiece width, we recommend the maximum depth of cut (per pass) be no more than 1/16". A series of light cuts will give better end results and put less stress on the planer than trying to take off too much material in a single pass.

The depth of cut can be referenced directly from the inch/millimeter scale on the front of the planer, as shown.

**Note:** *The scale functions as a general guide only, and is not intended for low-tolerance, precision results.*

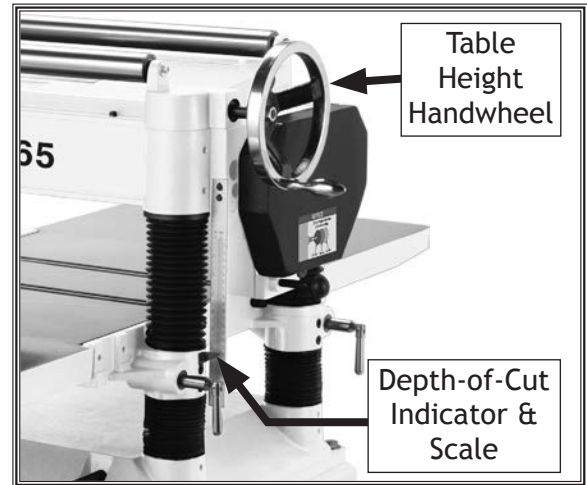


Figure 19. Location of depth-of-cut controls (W1865 shown).

# Bed Roller Height

Bed Roller Height Range ..... 0.002"-0.020"

The correct height of the bed rollers will vary, depending on the type of material you intend to plane. However, as a general rule, keep the bed roller height within 0.002"-0.020" above the table surface, as illustrated in Figure 20.

When planing rough stock, set the rollers high to keep the lumber from dragging along the bed. When planing milled lumber, set the rollers low to help minimize snipe.

To ensure accurate results and make the adjustment process quicker and easier, we recommend using a Rotacator (refer to Page 36) to gauge the bed roller height from the table surface. If a Rotacator is not available, a straightedge and feeler gauges can be used, but care must be taken to achieve accurate results.

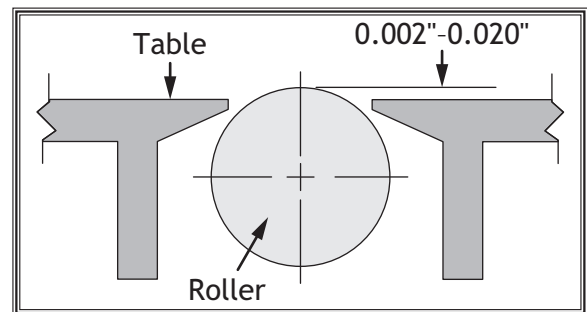


Figure 20. Recommended bed roller height above the table surface.

## NOTICE

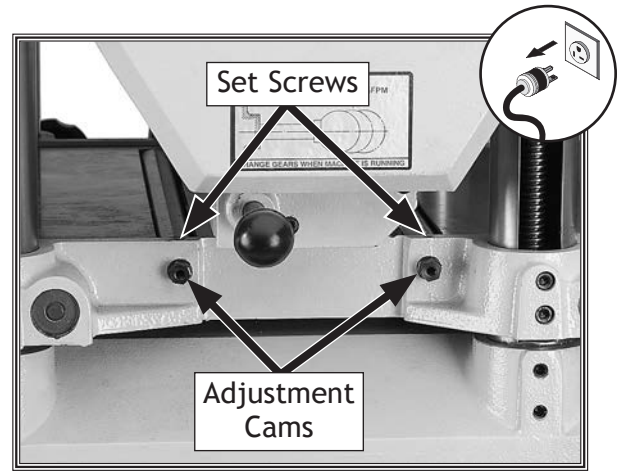
Bed rollers that are not adjusted to the correct height or out of alignment with each other can cause poor finishes, inconsistent planing thickness, and other undesirable results.



Items Needed	Qty
Hex Wrench 3mm .....	1
Open-End Wrench 14mm.....	1
Straightedge 36" .....	1
Feeler Gauge Set .....	1
Rotacator (optional, refer to <b>Page 36</b> ) .....	1

**To adjust bed rollers, do these steps:**

1. DISCONNECT MACHINE FROM POWER!
2. Completely lower table to give yourself enough room to work.
3. Loosen set screws (see **Figure 21**) above each of four roller adjustment cams (there are two on each side of planer).
4. Rotate eccentric adjustment cams to raise or lower bed rollers to desired height above table surface.
5. Verify both sides of each roller are at the same height, then re-tighten set screws to secure in place.
6. Re-check roller heights to make sure they did not change while being secured.
  - If roller heights are not correct, repeat this procedure until they are.



**Figure 21.** Bed roller height controls.

# Setting Feed Rate

High Feed Rate ..... 28 FPM  
 Low Feed Rate ..... 16 FPM

The infeed and outfeed rollers move the workpiece through the planer while keeping it flat and providing a consistent rate of movement. The speed that these rollers move the workpiece through the planer is the feed rate.

Generally, low feed rates are used for dimensioning, while higher feed rates are used for finishing.

The figure below illustrates the three different positions of the feed rate control knob:

- Push knob in to use high feed rate.
- Pull the knob out to use the low feed rate.
- Move knob to center position to place gearbox in neutral.

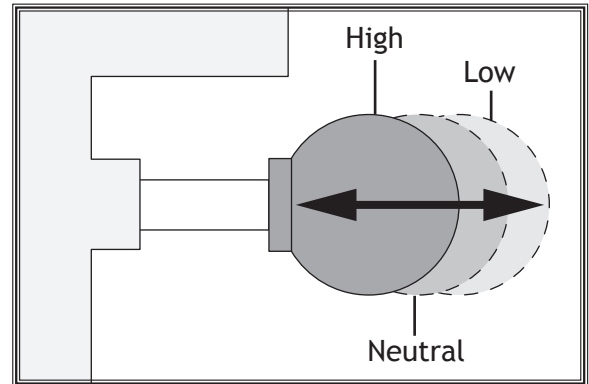
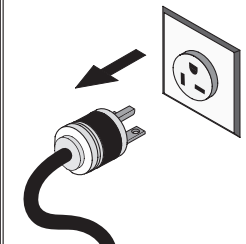


Figure 22. Feed rate control knob positions.

**NOTICE**

Only change the feed rate when the planer is running, but **DO NOT** attempt to change the feed rate during any cutting operations or damage to the gearbox will result.

# Adjusting/Replacing Knives (W1864)



⚠ WARNING

To reduce risk of shock or accidental startup, always disconnect machine from power before adjustments, maintenance, or service.

Setting the height of the knives correctly is crucial to the proper operation of your planer and is very important in keeping the knives sharp. If one knife protrudes higher than the others, it will do the majority of the work, dull much faster, and produce poor cutting results.

The knife-setting jig included with this planer is designed to set the knives at a uniform distance of 0.070" above the cutterhead surface.

**Note:** If you need to replace or sharpen a knife, you can remove the knife from the cutterhead during **Step 4** of the following procedure. Thoroughly clean out any debris from the knife slots before replacing the knives.

**⚠ CAUTION**

Cutterhead knives are extremely sharp. Contact with knives can result in severe cuts. Take great caution whenever working with or around cutterhead knives. Wear heavy leather gloves to reduce risk of severe cuts.

**NOTICE**

To maintain accurate and consistent planing results, we do not recommend sharpening knives yourself. Instead, just replace dull knives or have them professionally sharpened.

OPERATIONS

Items Needed	Qty
Phillips Screwdriver #2.....	1
Wrench or Socket 12mm, 13mm.....	1 Ea.
Hex Wrench 3mm .....	1
Knife-Setting Jig .....	1
Heavy Leather Gloves.....	1 Pair

**To adjust height of knives, do these steps:**

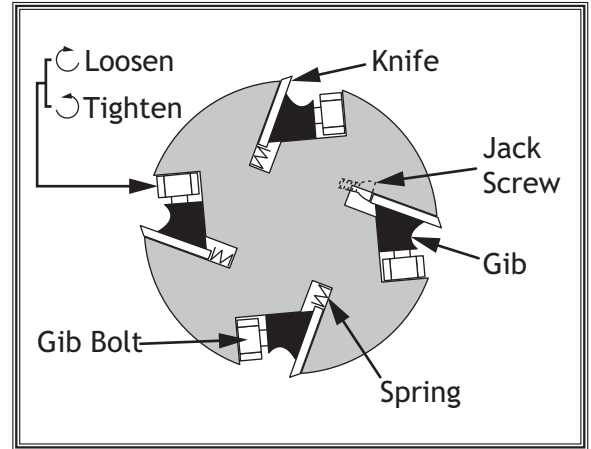
1. DISCONNECT MACHINE FROM POWER!
2. Remove dust hood and top cover to expose cutterhead.
3. Put on heavy leather gloves.
4. Remove belt cover, then rotate cutterhead pulley to provide access to one of the knives.

**Note:** The cutterhead for Model W1864 ships with both springs and jack screws to adjust the knife height (see **Figure 23**)—which one you use is up to your personal preference. However, if you use the springs, you must first remove the jack screws from the cutterhead before proceeding.

– The advantage of using springs is that springs maintain a constant upward pressure on the knives while using the knife-setting jig during **Step 6**.

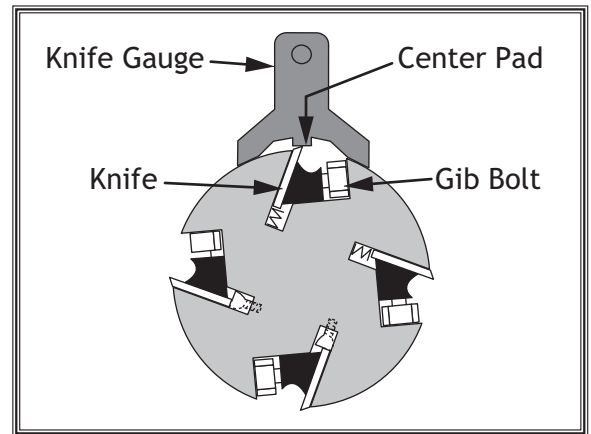
– The advantage of using jack screws is that once you set the proper height of the screws, they should require little to no adjustment when replacing the knives.

5. Loosen cutterhead gib bolts until knife is completely loose.
  - If you are replacing the knives, remove the old knife and install the new one, making sure the beveled edge of the new knife is facing the correct direction.
6. Position knife-setting jig over knife so that knife edge is directly under center pad, as shown in **Figure 24** to right.



**Figure 23.** W1864 cutterhead components.

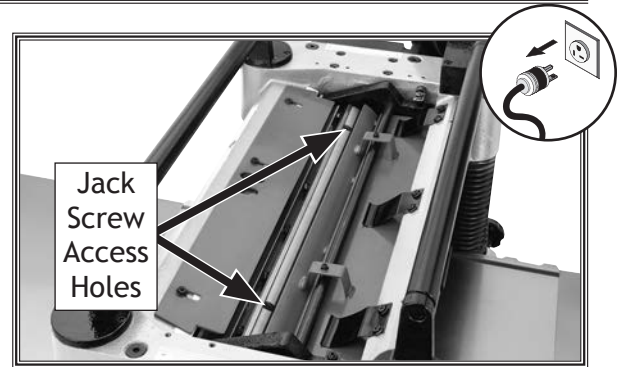
OPERATIONS



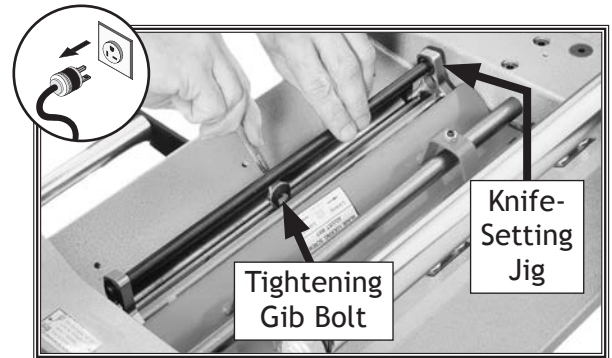
**Figure 24.** Knife-setting jig correctly positioned over knife.

7. **Jack Screws:** Insert hex wrench into access holes in cutterhead (see **Figure 25**), and rotate jack screws to raise or lower knife until it barely touches center pad of knife-setting jig with all legs of jig still firmly on cutterhead, then snug gib bolts enough to hold knife in place without fully tightening gib bolts (see **Figure 26**).

**Springs:** Insert hex wrench into access holes in cutterhead (see **Figure 25**), and remove jack screws. Push down on knife jig until all legs of jig are firmly on cutterhead and knife just touches center pad of jig, then tighten gib bolts enough to hold knife in place without fully tightening gib bolts (see **Figure 26**).

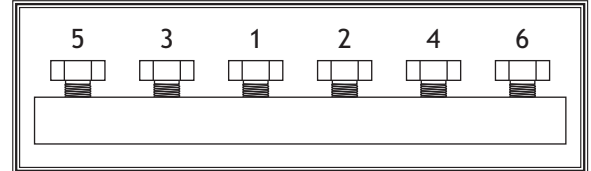


**Figure 25.** Jack screw access holes in cutterhead.



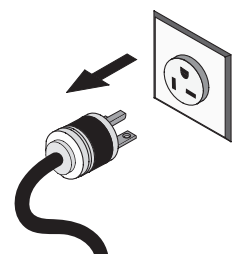
**Figure 26.** Using knife-setting jig to set knife height.

8. Incrementally snug gib bolts in an even manner, starting at middle and working your way to ends by alternating left and right, as illustrated in **Figure 27**.
9. Repeat **Step 8**, snugging gib bolts a little more.
10. Repeat **Step 8**, this time fully tightening all gib bolts.
11. Repeat **Steps 4-8** for remaining knives.



**Figure 27.** Gib bolt tightening sequence.

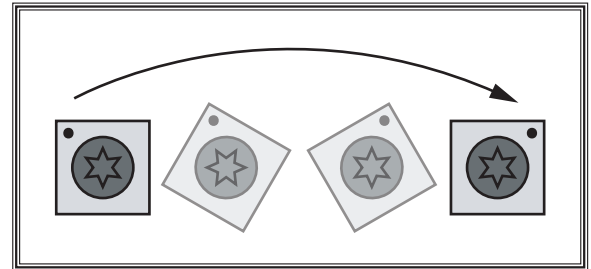
# Rotating/Replacing Cutterhead Inserts (W1865)



**⚠ WARNING**  
To reduce risk of shock or accidental startup, always disconnect machine from power before adjustments, maintenance, or service.

The helical cutterhead is equipped with indexable carbide inserts that can each be rotated to reveal one of four cutting edges. If one edge of the insert becomes dull or damaged, simply rotate it 90° to reveal a fresh cutting edge, as shown in **Figure 28**.

Items Needed	Qty
Phillips Screwdriver #2.....	1
Wrench or Socket 10mm.....	1
Torque Wrench .....	1
T-25 Torx Bit .....	1
Heavy Leather Gloves .....	1 Pair
Light Machine Oil .....	As Needed



**Figure 28.** Rotation of insert to reveal fresh cutting edge.

OPERATIONS

To rotate or replace a helical cutterhead insert, do these steps:

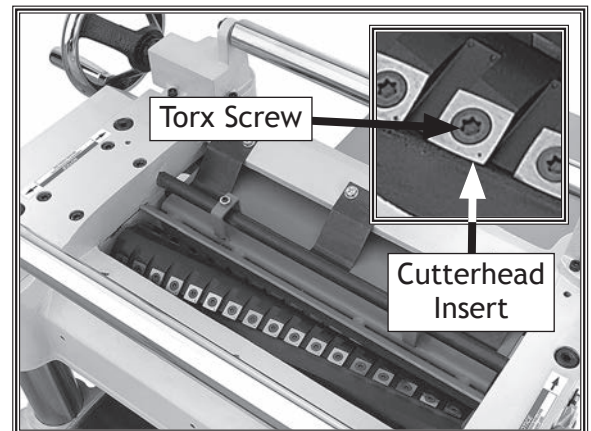
1. DISCONNECT MACHINE FROM POWER!
2. Remove dust port, top cover, and belt cover.
3. Put on heavy leather gloves to protect your fingers and hands.
4. Remove any sawdust or debris from head of insert, Torx screw, and surrounding area (see **Figure 29**).
5. Remove Torx screw and insert, then clean all dust and debris from both parts and cutterhead pocket.

**Note:** Proper cleaning of insert, Torx screw, and cutterhead pocket is critical to achieving a smooth finish. Dirt or dust trapped between insert and cutterhead will raise insert, and make marks on your workpiece when planing.

**Tip:** Use low-pressure compressed air or a vacuum nozzle to clean out cutterhead pocket.

**⚠ CAUTION**

The carbide inserts are very sharp and can quickly cut your hands. ALWAYS use caution and heavy leather gloves when handling these parts to reduce the risk of personal injury.



**Figure 29.** W1865 cutterhead inserts and Torx screws.

6. Rotate insert 90° and install so that a fresh cutting edge faces outward (see Figure 30).
  - When all four insert cutting edges have been used, replace insert with a new one. Always position new insert reference dot in same position to aid in rotational sequencing.
7. Lubricate Torx screw threads with a very small amount of light machine oil, wipe excess off, and torque screw to 50-55 inch/pounds.

**Note:** *If too much oil is applied to the threads, excess oil will attempt to squeeze out of the threaded hole and raise insert during installation, bringing it out of height alignment.*

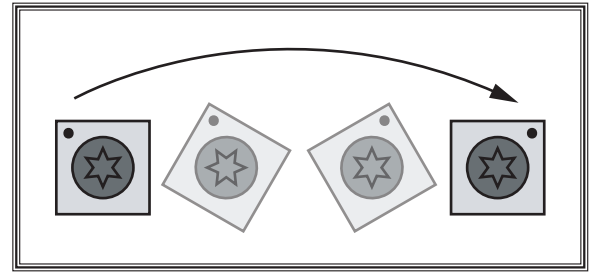


Figure 30. Insert rotating sequence.

# ACCESSORIES

## Planer Accessories

The following planer accessories may be available through your local Woodstock International Inc. Dealer. If you do not have a dealer in your area, these products are also available through online dealers. Please call or e-mail Woodstock International Inc. Customer Service to get a current listing of dealers at: 1-800-840-8420 or at [sales@woodstockint.com](mailto:sales@woodstockint.com).

### W1218A—Rotacator™ Precision Planer Tool

The Rotacator is a dial indicator on a magnetic base, designed for quickly and accurately setting the critical tolerances needed when making planer adjustments. Perfect for adjusting infeed/outfeed rollers, pressure bars, chip breakers, and bed rollers. Also a great setup tool for other machines! Accurate to 0.001". Indicator rotates 360°.

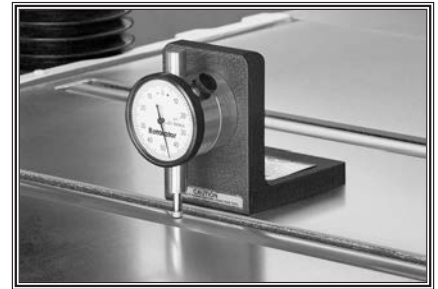


Figure 31. W1218A Rotacator™ Precision Planer Tool.

### D4112—Fractional Digital Caliper 6"

Large LCD readout converts to decimal inch, fractional inch, and millimeters, with the push of a button. Measure internal and external dimensions, depth, steps, and differential measurements. Features thumb roll and stainless steel construction. Range: 0-6", 0-150mm. Resolution: 0.0005", 0.01mm,  $\frac{1}{128}$ ".

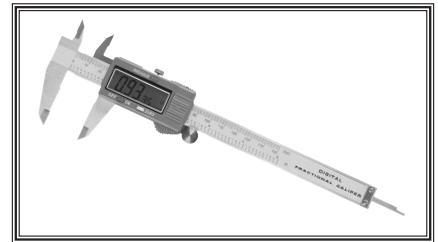


Figure 32. Model D4112 Fractional Digital Caliper 6".

### D2273—Single Roller Stand

Large diameter ball bearing roller stand features smooth operation for a variety of processing and work support applications. Heavy pedestal base is stable and secure.

### D2274—5-Roller Stand

For greater work stability and support, this 5 roller stand features large diameter, ball bearing rollers mounted on a sturdy adjustable pedestal base.



Figure 33. Models D2273 and D2274 Roller Stands.



**D2058A—Heavy-Duty Adjustable Mobile Base**

This patented base is the most stable on the market with outrigger-type supports. Adjusts from 18<sup>1</sup>/<sub>2</sub>" x 24<sup>1</sup>/<sub>2</sub>" to 28<sup>1</sup>/<sub>2</sub>" x 33<sup>1</sup>/<sub>2</sub>". 1300 lb. capacity. Weighs 39 lbs.

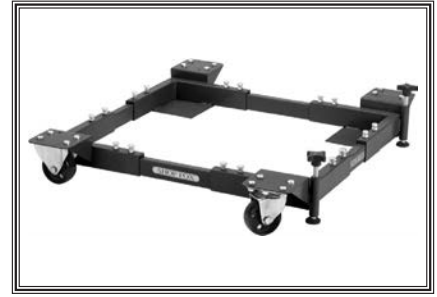


Figure 34. D2058A Adjustable Mobile Base.

**For W1864:**

**D3097—20" Planer Knives, Set of 4**

These planer knives are made from high-speed steel and fit Model W1864 20" Planer. Set of 4.

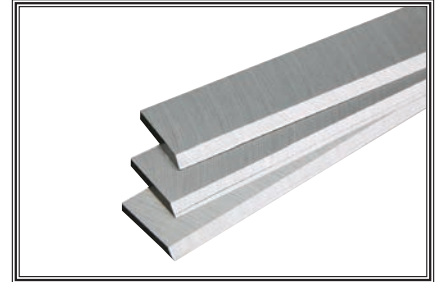


Figure 35. D3097 20" Planer Knives.

**For W1865:**

**D4297—Indexable Carbide Inserts, 10 Pack**

These Indexable Carbide Inserts are designed for use in helical cutterhead systems and made to last up to 10 times longer than a set of HSS steel inserts. Made of solid carbide. Size: 15 x 15 x 2.5mm.

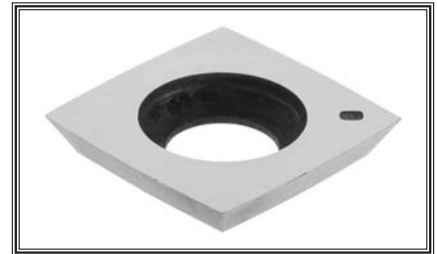


Figure 36. D4297 Indexable Carbide Inserts.



# MAINTENANCE



## Schedule

For optimum performance from your machine, follow this maintenance schedule and refer to any specific instructions given in this section.

**Note:** *This maintenance schedule is based on average daily usage. Adjust the maintenance schedule to match your usage, to keep your planer running smoothly, and to protect your investment.*

### Ongoing

- Clean machine and protect unpainted cast-iron surfaces.
- Lubricate feed roller bushings (Page 39).
- Tighten loose mounting bolts.
- Check/sharpen/replace damaged or worn knives/inserts (Page 31).
- Check/repair/replace worn/damaged wires.
- Resolve any other unsafe condition.

### Every 40 Hours of Operation

- Clean cutterhead and, for W1864, check knife height (Page 31).
- Lubricate table columns and leadscrews (Page 39).

### Every 160 Hours of Operation

- Check/tension/replace V-belts (Page 41).
- Clean/vacuum dust buildup from inside cabinet and off motor.
- Lubricate table height worm gear (Page 39).
- Lubricate table height chain and sprockets (Page 39).
- Lubricate drive chain and sprockets (Page 40).

### Yearly

- Change gearbox oil (Page 40).

## Cleaning & Protecting

Vacuum excess wood chips and sawdust, and wipe off the remaining dust with a dry cloth. If any resin has built up, use a resin-dissolving cleaner to remove it.

Protect the unpainted cast-iron table by wiping it clean after every use—this ensures moisture from wood dust does not remain on bare metal surfaces. Keep your table rust-free with regular applications of quality lubricants.

## Lubrication

### NOTICE

Failure to follow reasonable lubrication practices as instructed in this manual for your machine could lead to premature failure of components and void the warranty.

This planer features bearings that are lubricated and sealed at the factory. These bearing do not require any further attention unless they need to be replaced. If a bearing fails, your planer will probably develop a noticeable rumble or vibration, which will increase when the machine is under a load. The bearings are standard sizes and can be replaced through Woodstock International.

Follow the maintenance schedule on this page and the procedures beginning on Page 39 to properly lubricate the other planer components, which are essential for long life and trouble-free operation of your planer.

### Feed Roller Bushings

Oil Type..... ISO-68  
Oil Amount ..... 2-3 Drops  
Frequency ..... Every 8 Hours of Operation

The infeed and outfeed rollers rotate inside bushing blocks on both ends of the rollers. Add 2-3 drops of ISO 68 machine oil to the center hole of the four feed roller tension adjustment bolts on top of the head casting, as shown in **Figure 37**.

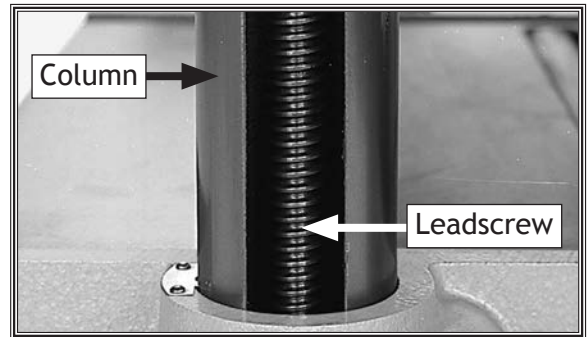


**Figure 37.** Lubrication locations for feed roller bushings.

### Columns & Leadscrews

Oil Type..... ISO-68  
Oil Amount ..... Thin Coat  
Grease Type..... NLGI#2 Equivalent  
Frequency ..... Every 40 Hours of Operation

The table rides on the columns and is moved by the rotation of the leadscrews inside the columns. Loosen the dust sleeve (see **Figure 38**) to access the columns and leadscrews. Apply a thin coat of ISO 68 machine oil to the outside surface of the columns and brush on a light application of multi-purpose grease to the leadscrew threads. Move the table up and down to distribute the lubricant.

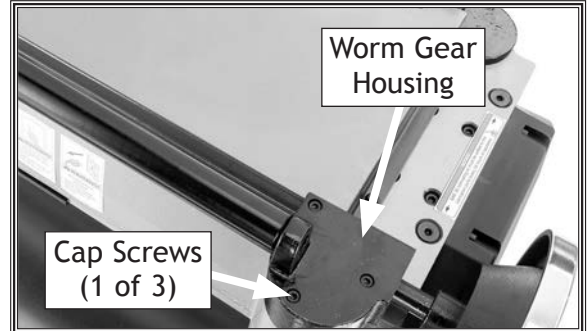


**Figure 38.** Location of column and leadscrew.

### Table Height Worm Gear

Grease Type..... NLGI#2 Equivalent  
Frequency ..... Every 160 Hours of Operation

Remove the three cap screws that secure the worm gear housing (see **Figure 39**), then lift the housing and handwheel assembly off the machine. Clean away any debris from the housing and gears, then brush on a moderate amount of multi-purpose grease to the gear teeth.

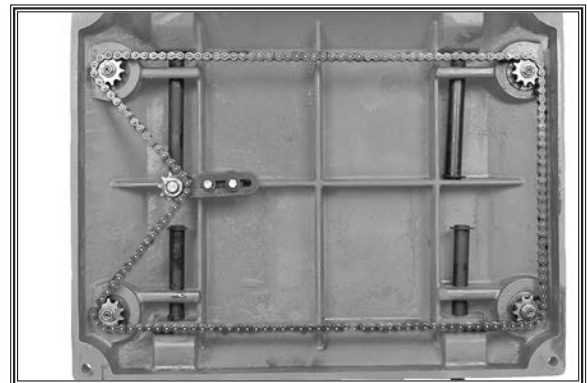


**Figure 39.** Example of table height worm gear housing.

### Table Height Chain & Sprockets

Grease Type..... NLGI#2 Equivalent  
Frequency ..... Every 160 Hours of Operation

The table leadscrews are synchronized by the table height chain and sprockets located underneath the planer base (see **Figure 40**). Use shop rags and mineral spirits to clean away debris and grime, then brush on a light coat of multi-purpose grease to the chain and sprockets.



**Figure 40.** Table height chain and sprockets as viewed from underneath the base.

## Drive Chain & Sprockets

Grease Type..... Synthetic Grease  
 Frequency..... Every 160 Hours of Operation

The infeed and outfeed rollers receive the transferred power from the cutterhead through the drive chain system on the right side of the machine, as shown in **Figure 41**.

Remove the table height handwheel and the safety covers attached to the inside of the drive chain cover, then remove the cover to access these parts.

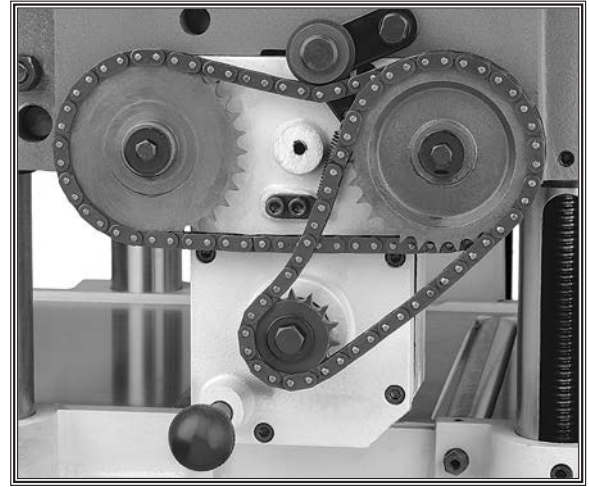
Use shop rags and mineral spirits to clean away any debris and grime, then brush on a light coat of multi-purpose grease to the chain and sprockets.

## Gearbox Oil

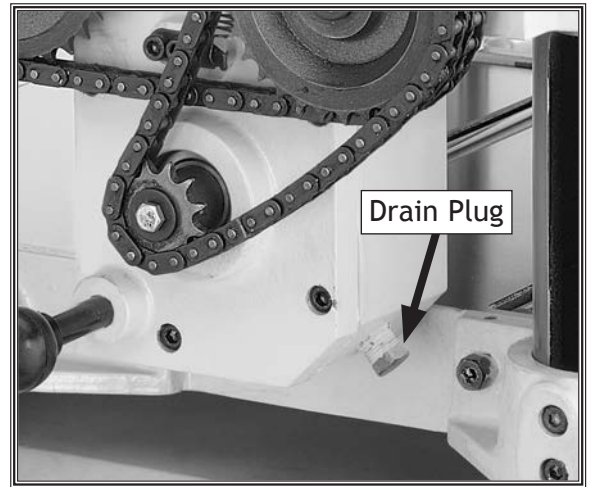
Oil Type..... ISO-320  
 Oil Amount..... 20 Oz.  
 Frequency..... After First 20 Hours, Then Yearly

**Note:** We recommend that you replace the gearbox oil after the first 20 hours of operation. This is a normal break-in procedure and will help maximize the service life of the machine by flushing away any particles from the break-in and manufacturing process.

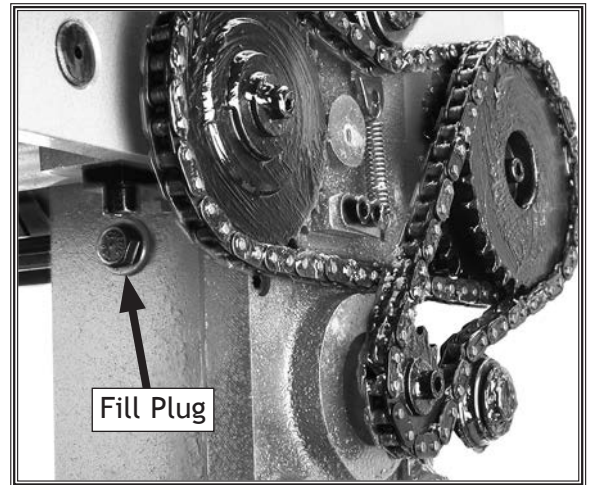
Although it is not necessary to remove the drive chain cover to access the fill and drain plugs, it is more convenient to do so (see **Figures 42-43**). Replace the gearbox oil with ISO 320 or equivalent oil until it just reaches the fill plug.



**Figure 41.** Example of drive chains and sprockets for infeed and outfeed rollers.



**Figure 42.** Example of gearbox drain plug.



**Figure 43.** Example of gearbox fill plug.

# SERVICE

## General

This section covers the most common service adjustments or procedures that may need to be made during the life of your machine.

If you require additional machine service not included in this section, please contact Woodstock International Technical Support at (360) 734-3482 or send e-mail to: [techsupport@woodstockint.com](mailto:techsupport@woodstockint.com).

## Tensioning/Replacing V-Belts

Three V-belts transfer power from the motor to the cutterhead, and then to the infeed and outfeed rollers with the use of the drive chain system. To ensure efficient transfer of power to these systems, make sure the V-belts are always properly tensioned and in good condition.

If the V-belts are worn, cracked, or damaged, replace them. Always replace the V-belts with a matched set of three, or belt tension may not be even among the belts, causing premature belt failure.

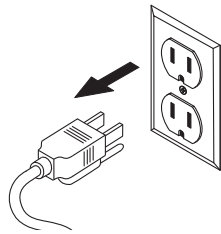
Items Needed	Qty
Phillips Screwdriver #2.....	1
Open-End Wrench 19mm.....	1

To tension/replace V-belts, do these steps:

1. DISCONNECT MACHINE FROM POWER!
2. Remove V-belt cover from left side of machine to expose belts, as shown in Figure 44.

**Note:** A collection of black belt dust at the bottom of the belt cover is normal during the life of the belts.

**⚠ WARNING**



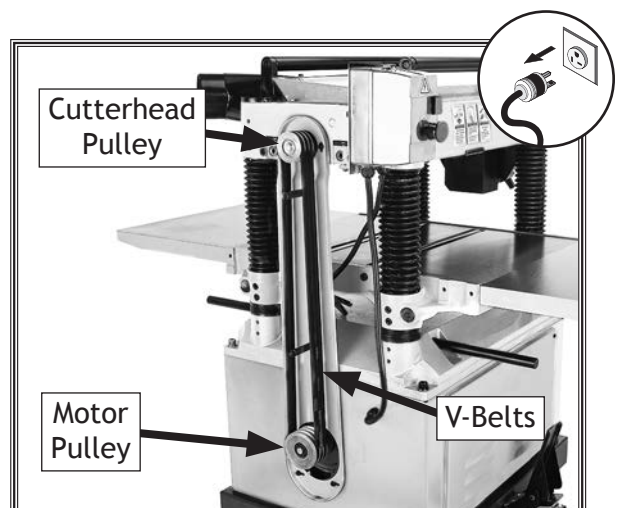
**MAKE SURE** that your machine is unplugged during all service procedures! If this warning is ignored, serious personal injury may occur.

**NOTICE**

After approximately 16 hours of operation, V-belts will stretch and seat into pulley grooves and need to be properly tensioned to avoid severely reducing life of V-belts.

**⚠ CAUTION**

V-belts and pulleys will be hot after operation. Allow them to cool before handling.



**Figure 44.** Example of belt cover removed to expose V-belts and pulleys.

**SERVICE**



3. Remove front cabinet cover to access motor, as shown in Figure 45.
4. If V-belts need to be replaced, raise motor to release belt tension (see Step 5 for instructions), roll belts off pulleys, then replace with a matched set of 3.
5. To adjust V-belt tension, loosen top belt tension hex nuts (see Figure 45), then adjust bottom hex nut to raise or lower motor.

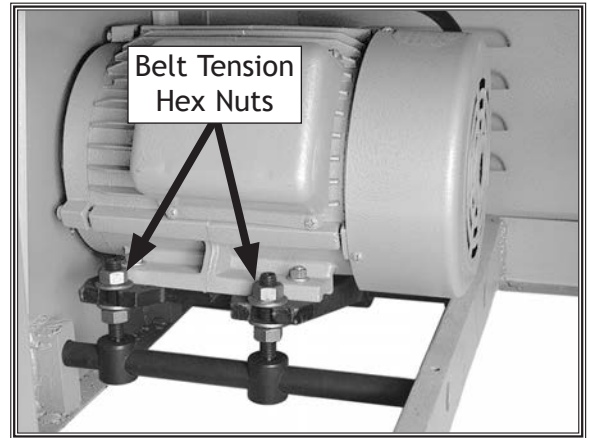


Figure 45. Front cabinet cover removed to access motor.

**Note:** V-belts are correctly tensioned when there is approximately  $\frac{3}{4}$ " deflection when moderate pressure is applied to belts midway between pulleys, as illustrated in Figure 46.

6. After V-belts are correctly tensioned, tighten top bent tension hex nuts, then re-install cabinet cover and belt cover.

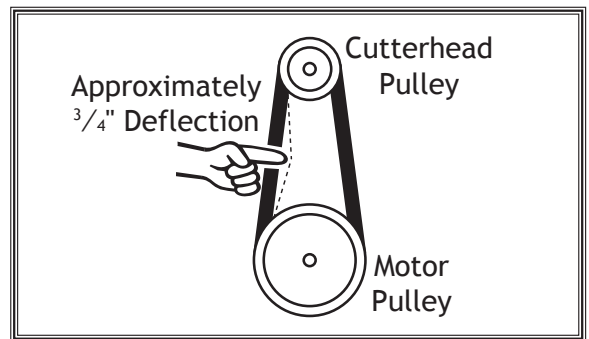


Figure 46. Belt deflection when V-belts are correctly tensioned.

## Checking/Adjusting Pulley Alignment

Pulley alignment prevents premature V-belt wear and unnecessary load on the motor. The pulleys are aligned when they are parallel and in the same plane as each other.

Items Needed	Qty
Straightedge 3' .....	1
Wrench or Socket 14mm, 17mm.....	2 Ea.

To check/re-align pulleys, do these steps:

1. DISCONNECT MACHINE FROM POWER!
2. Remove belt cover, then use straightedge to check pulley alignment, as shown in Figure 47.

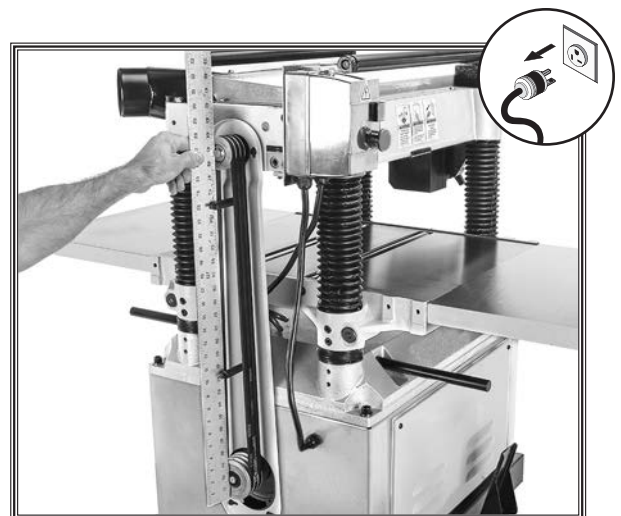


Figure 47. Example of checking pulley alignment.

- If pulleys *are* parallel and in the same plane, no adjustment is necessary. Re-install belt cover.
  - If pulleys are *not* parallel or in the same plane, remove motor access panel, then proceed to **Step 3**.
3. Loosen four motor mount bolts (see **Figure 48**), shift motor until pulleys are aligned, then re-tighten motor mount bolts.
  4. Re-check pulleys and repeat **Step 3** as necessary until pulleys are aligned, then re-tighten all fasteners, and replace belt cover and motor access panel.

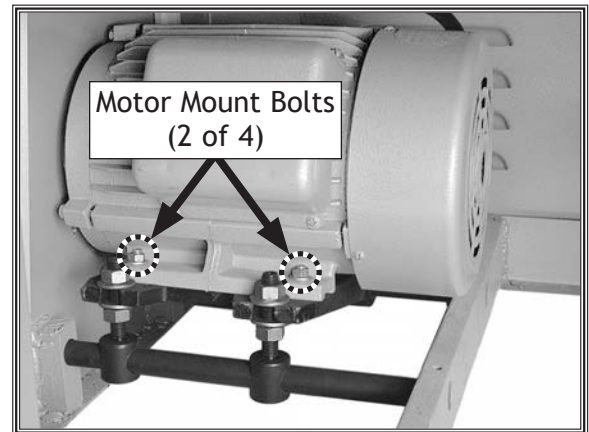


Figure 48. Location of motor mount bolts.

## Setting Feed Roller, Chip Breaker & Pressure Bar Heights

It is essential that the feed rollers and chip breaker are set at the correct distance below the cutterhead knives at BDC (bottom dead center) to ensure that the workpiece moves through the planer evenly and the correct distance from the cutterhead knives.

To ensure accurate results and make the adjustment process quicker and easier, we recommend using a Rotacator for these adjustments (refer to **Accessories**).

If a Rotacator is not available, a 6' 2x4 cut into two even sized pieces and a feeler gauge set can be used, but care must be taken when jointing the wood to achieve accurate results.

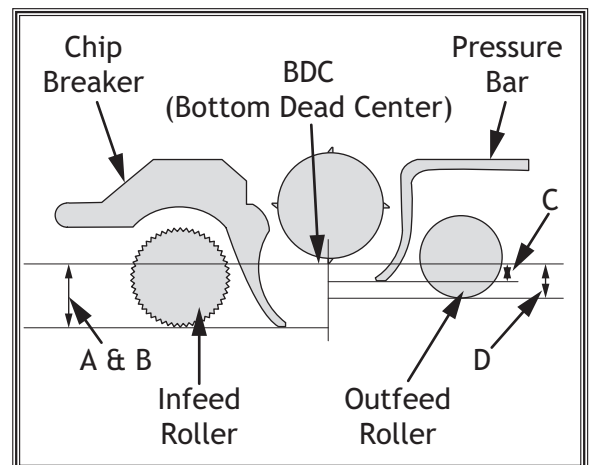


Figure 49. Planer component recommended clearances (illustration is not to scale).

### Distance Below Knife/Insert at BDC (Figure 49)

A. Infeed Roller .....	0.040"
B. Chip Breaker .....	0.040"
C. Pressure Bar .....	0.008"
D. Outfeed Roller .....	0.020"

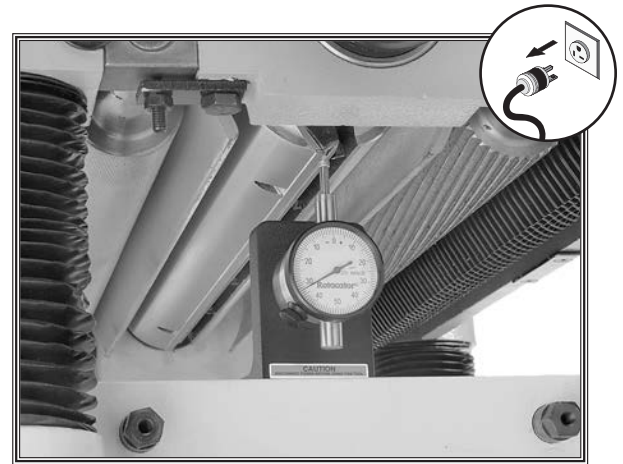
### Using a Rotacator

Items Needed	Qty
Phillips Screwdriver #2.....	1
Hex Wrenches 3mm, 5mm.....	1 Ea.
Wrench or Socket 10mm.....	1 Ea.
Rotacator (see <b>Page 36</b> ).....	1

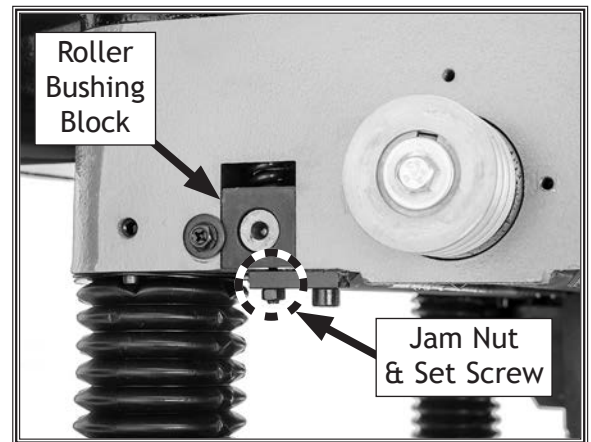


To use a Rotacator, do these steps:

1. DISCONNECT MACHINE FROM POWER!
2. Make sure knives are set to correct height (refer to **Adjusting/Replacing Knives** on **Page 31** for detailed instructions). If machine is helical cutterhead, make sure all inserts are properly installed (refer to **Rotating/Replacing Cutterhead Inserts** on **Page 33** for detailed instructions).
3. Lower table at least 4" below head casting, then lock it in place.
4. Remove dust port, top cover, belt cover, and drive chain cover.
5. Using your Rotacator, find bottom dead center (BDC) of any knife/insert edge by slowly rocking cutterhead pulley back and forth, then set Rotacator dial to "0" (see **Figure 50**).
6. Move feed speed knob to neutral position to allow infeed roller to freely rotate.
7. Keeping Rotacator dial at "0", position it under right-hand side of infeed roller and find BDC of a serrated edge by rocking infeed roller back and forth.
8. Loosen jam nuts and use set screws on each side of feed roller (see **Figure 51**) to adjust height of infeed roller bushing block until Rotacator dial shows 0.040", which is the recommended distance for infeed roller below cutterhead.
9. Repeat **Steps 7-8** on left side of infeed roller.
10. Re-check both sides of infeed roller and, if necessary, make further adjustments until infeed roller height from side-to-side is 0.040" below BDC of cutterhead knife, then retighten both jam nuts.
11. Keeping same "0" reference on Rotacator dial from **Step 5**, repeat **Steps 7-10** for outfeed roller, but adjust it until it is 0.020" below BDC of cutterhead knife.



**Figure 50.** Example of using a Rotacator to find BDC.



**Figure 51.** Example of infeed roller bushing block and height adjustment controls.

12. Using same "0" reference on Rotacator dial from Step 5, perform similar steps as described previously to adjust height of chip breaker to its recommended specification given at beginning of this subsection. (The adjustment controls are shown in Figure 52.)
13. Repeat Step 12 for pressure bar height adjustment (see Figure 52).
14. Re-install belt cover, top cover, drive chain cover, and dust port.

### Using Wood Blocks

Items Needed	Qty
Phillips Screwdriver #2.....	1
Hex Wrench 3mm, 5mm .....	1
Wrench or Socket 10mm.....	1
2x4 6' Long.....	1
Feeler Gauge Set .....	1

To use wood blocks, do these steps:

1. Build wood blocks by cutting a straight 6-foot-long 2x4 in half.

**Note:** Having the wood blocks at an even height is critical to the accuracy of your overall adjustments. For best results, make the 2x4 square with a jointer and table saw before cutting it in half.

2. **W1864 Only:** Make sure knives are set to correct height (refer to **Adjusting/Replacing Knives** on Page 31 for detailed instructions).
3. **DISCONNECT MACHINE FROM POWER!**
4. Lower bed rollers below table surface (refer to **Bed Roller Height** on Page 29 for detailed instructions).
5. Place wood blocks along sides of table, as illustrated in Figure 53.

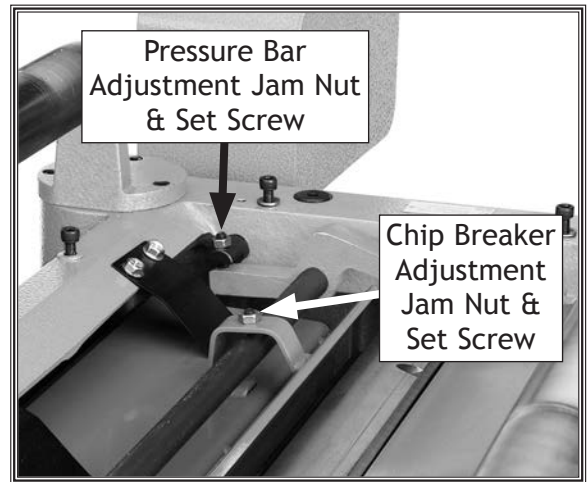


Figure 52. Location of chip breaker and pressure bar height adjustment components.

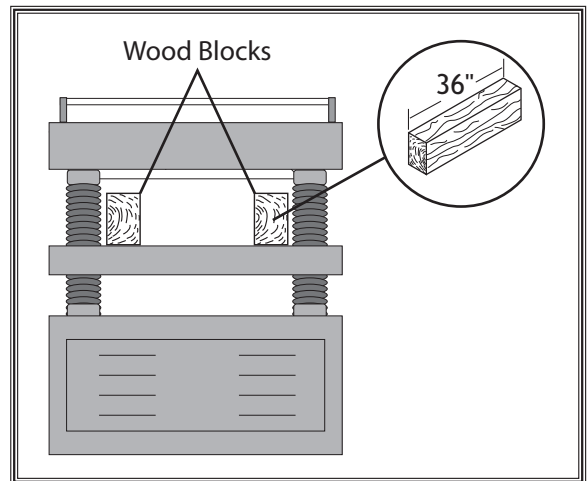
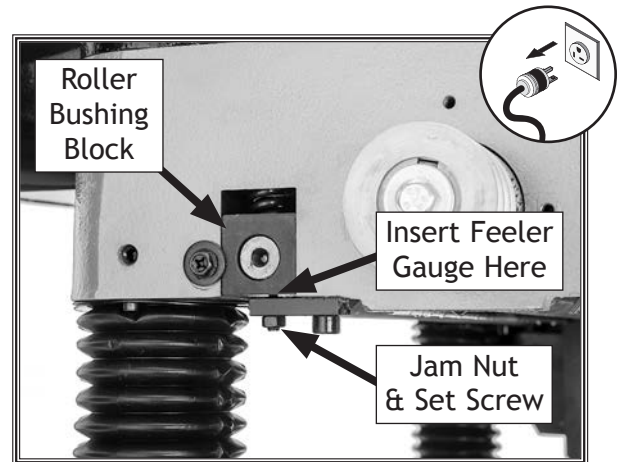


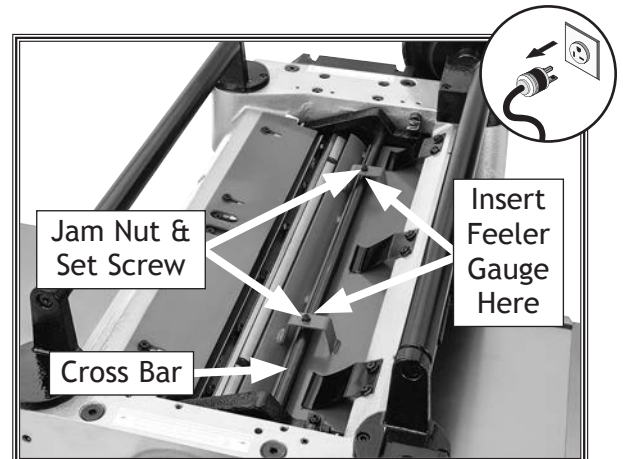
Figure 53. Wood blocks properly positioned on the planer table.

6. Remove dust port, top cover, belt cover, and drive chain cover.
7. Raise table until wood blocks get close to cutterhead.
8. Use belt to rotate cutterhead and continue raising table until blocks just barely touch cutterhead knife/insert at its lowest point of rotation (BDC).
9. Lock table in place. Upward pressure of wood blocks will be holding infeed and outfeed rollers, chip breaker, and pressure bar at same level as knife/insert at BDC.
10. Loosen jam nuts and set screws on each side of infeed roller (see **Figure 54**).
11. Using a feeler gauge, adjust set screw so it is 0.040" from roller bushing block (see **Figure 54**), then tighten jam nut. Repeat on other side of infeed roller.
12. Repeat **Steps 10-11** with outfeed roller, only adjust the gaps to 0.020".



**Figure 54.** Example of feeler gauge location for adjusting infeed roller height when using wood blocks (one of two locations shown).

13. Loosen jam nuts and set screws on each side of chip breaker (see **Figure 55**).
14. Using a feeler gauge, adjust set screw so it is 0.040" from cross bar (see **Figure 55**), then tighten jam nut. Repeat on other side of chip breaker.
15. Re-install belt cover, top cover, drive chain cover, and dust port.



**Figure 55.** Example of feeler gauge locations for adjusting chip breaker height when using wood blocks.

# Adjusting Feed Roller Spring Tension

The infeed and outfeed rollers keep the workpiece moving through the planer. Springs exert downward pressure on the feed rollers while allowing them to raise with an uneven workpiece surface. Proper spring tension is crucial to keep the workpiece moving through the planer during operation.

The ideal feed-roller spring tension varies depending upon the type of wood you plane. When adjusting spring tension, keep the following in mind:

- If you are planing milled lumber with a consistent surface, use less spring tension to reduce the risk of marring the workpiece.
- If you are planing rough lumber with inconsistent surfaces, use greater spring tension to keep the stock moving through the planer.
- If the workpiece consistently stops feeding during operation, the spring tension may need to be increased.

Items Needed	Qty
Hex Wrench 5mm .....	1

To adjust feed-roller spring tension, do these steps:

1. DISCONNECT MACHINE FROM POWER!
2. Rotate tension screws (see **Figure 56**) clockwise to increase tension or counterclockwise to decrease tension.

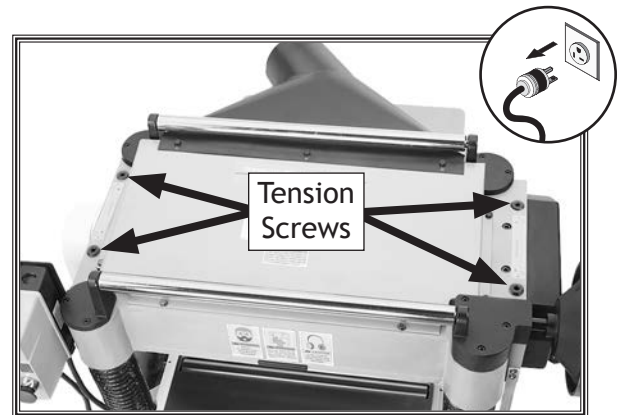


Figure 56. Example of roller spring tension adjustment screws.

# Positioning Chip Deflector

## Chip Deflector Gap Setting

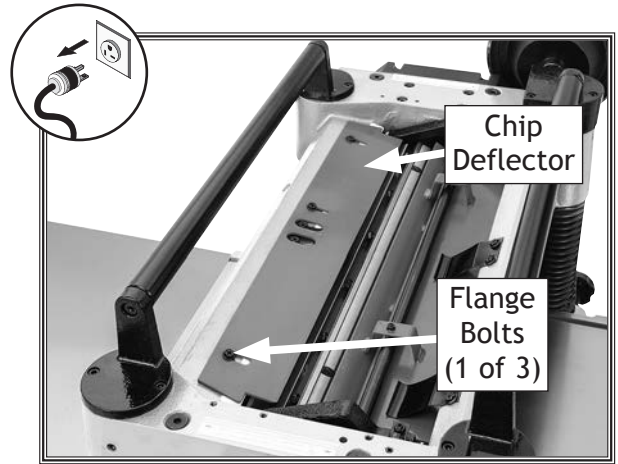
- If Planer Used w/Dust Collector..... 1/4"
- If Planer Used w/o Dust Collector ..... 1/16"

When properly distanced from the cutterhead, the chip deflector directs the chips into the dust hood, and keeps them from falling onto the outfeed roller and being pressed into the workpiece.

Items Needed	Qty
Wrench or Socket 10mm.....	1
Hex Wrench 5mm .....	1

To adjust chip deflector gap, do these steps:

1. DISCONNECT MACHINE FROM POWER!
2. Remove dust hood, top cover, and belt cover.
3. Use cutterhead pulley to rotate cutterhead until a knife/insert reaches closest distance to chip deflector (see **Figure 57**), then measure distance between knife/insert and chip deflector.
4. If distance measured in **Step 3** is *not* equal to correct chip deflector gap setting, then loosen flange bolts (see **Figure 57**) that secure chip deflector and adjust gap to correct setting.
5. Re-tighten flange bolts, then replace belt cover, top cover, and dust port.



**Figure 57.** Example of chip deflector and mounting hardware.



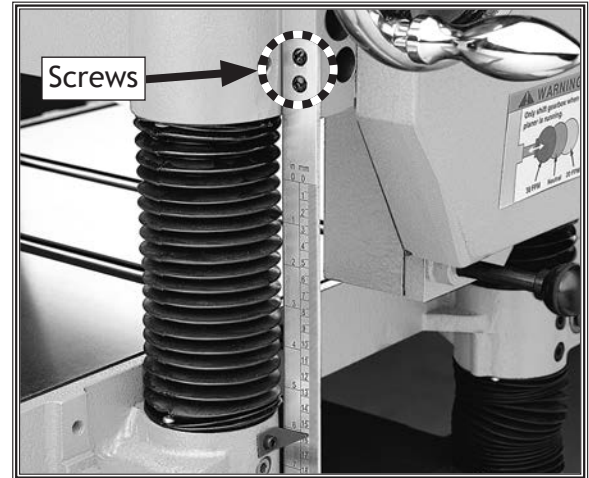
# Calibrating Table Elevation Scale

Although correctly set at the factory, the table elevation scale can be adjusted for accuracy if necessary.

Items Needed	Qty
Phillips Screwdriver #2.....	1
Scrap Piece of Stock.....	1
Calipers.....	1

To calibrate table elevation scale, do these steps:

1. Plane a scrap piece of stock until it is flat and of even thickness along its length.  
  
*Note: Turn board over between each pass.*
2. Use calipers to measure board thickness.
3. If there is a discrepancy between board thickness and reading on table elevation scale, loosen the screw shown in **Figure 58**, adjust scale as necessary, then re-tighten screw.



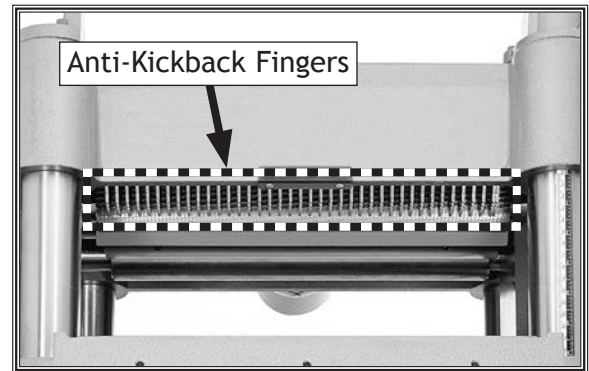
**Figure 58.** Location of adjustment screws for table height scale.

# Checking Anti-Kickback Fingers

The anti-kickback fingers are an important safety feature of your planer. The fingers hang from a rod suspended across the head casting and in front of the infeed roller, as shown. This design allows the workpiece to easily enter the planer but reduces the risk of kickback by digging into the workpiece if it moves backward.

Check the anti-kickback fingers regularly to ensure they swing freely and easily. If the fingers do not swing freely and easily, first clean them with a wood-resin solvent, then inspect them for damage. If any of the fingers are damaged, the device must be replaced before using the machine.

Do not apply oil or other lubricants to the anti-kickback fingers that will attract dust and restrict free movement of the fingers.



**Figure 59.** Anti-kickback fingers.

**⚠ WARNING**

Proper operation of anti-kickback fingers is critical for safe operation of this planer. **DO NOT** operate planer if anti-kickback fingers are not operating correctly. Failure to heed this warning could result in serious personal injury.

**SERVICE**



# Tensioning Table Height Chain

The table height chain transfers movement from the elevation handwheel to the columns that control table height. The chain drive can be adjusted to remove slack if the chain stretches over time or is loosened during table leveling procedures.

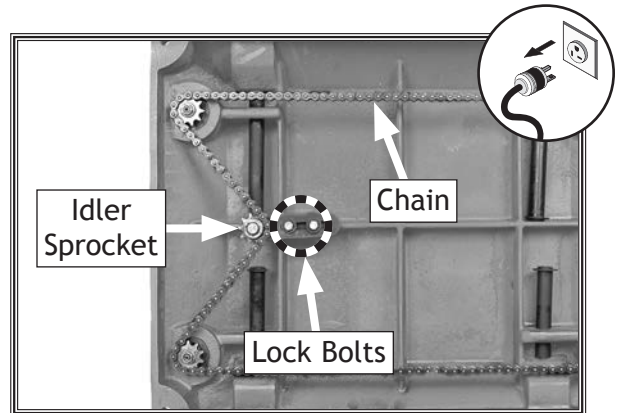
Items Needed	Qty
Phillips Screwdriver #2.....	1
Wrench or Socket 14mm.....	1

To adjust table height chain tension, do these steps:

1. DISCONNECT MACHINE FROM POWER!
2. Remove motor access panel to access table height chain shown in **Figure 60**.
3. Loosen two chain tension lock bolts, then push idler sprocket against chain with moderate pressure to eliminate slack in chain. While maintaining pressure on idler sprocket, re-tighten bolts (see **Figure 60**).
4. Clean and lubricate chain and sprockets (refer to **Table Height Chain & Sprockets** on **Page 39** for instructions), then re-install motor access panel.

**NOTICE**

DO NOT let chain fall off sprockets. It can be very difficult to return chain to its proper location on sprockets without changing table adjustments.



**Figure 60.** Table height chain adjustment (shown without stand for purpose of illustration).

# Adjusting Table Parallelism

**Maximum Allowable Tolerances:**

Cutterhead/Table Side-to-Side .....	0.002"
Head Casting/Table Front/Back .....	0.020"

Table parallelism is critical to the operation of the machine. As such, it is essential that the table is parallel with the cutterhead (within 0.002") from side-to-side, as illustrated in Figure 61.

Items Needed:	Qty
Rotacator .....	1
Phillips Screwdriver #2 .....	1
Wrench or Socket 14mm .....	1
Hex Wrench 6mm .....	1

How the table sits in relation to the head casting from front-to-back is also important (see Figure 62). Because the feed rollers, pressure bar, and chip breaker will be adjusted off the table position, the tolerances on the front-to-back positioning are not as critical as the cutterhead/table side-to-side positioning. Therefore, the maximum allowable tolerance for the front-to-back parallelism is not more than 0.020".

## Table Parallelism Inspection

Use your Rotacator to inspect the table parallelism. If you do not have a Rotacator, a wood block and feeler gauges may be used, but extra care must be taken to ensure accuracy. If the table is not within the maximum allowable tolerances, it must be adjusted.

## Table Parallelism Adjustments

The table is adjusted by turning the chain sprockets underneath the table for movements over 0.016" or by adjusting how the table is mounted on the columns for movements under 0.016".

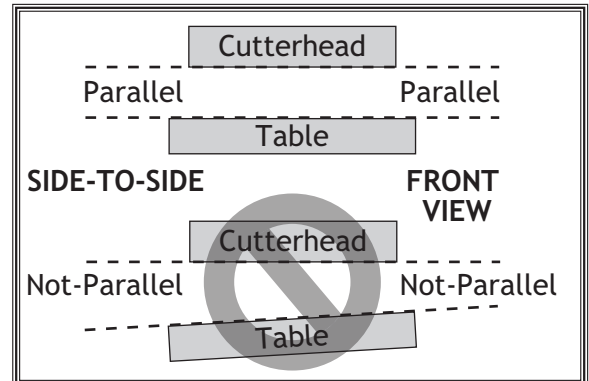


Figure 61. Side-to-side parallelism of table and cutterhead.

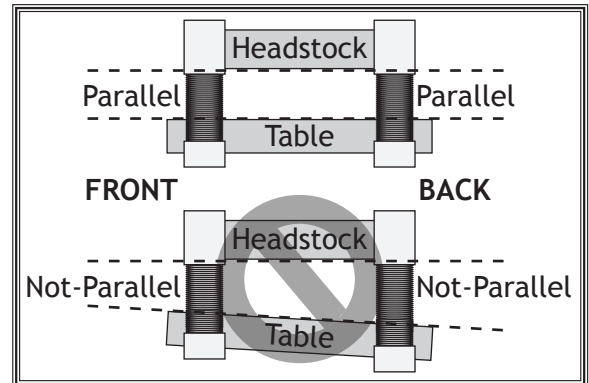


Figure 62. Front-to-back parallelism of table and cutterhead.

## NOTICE

When making adjustments, tighten fasteners after each step to ensure the accuracy of your tests. When adjusting the chain sprockets, keep in mind that if the chain becomes too loose, it will fall off of all the sprockets, and returning it to its proper location can be extremely difficult.

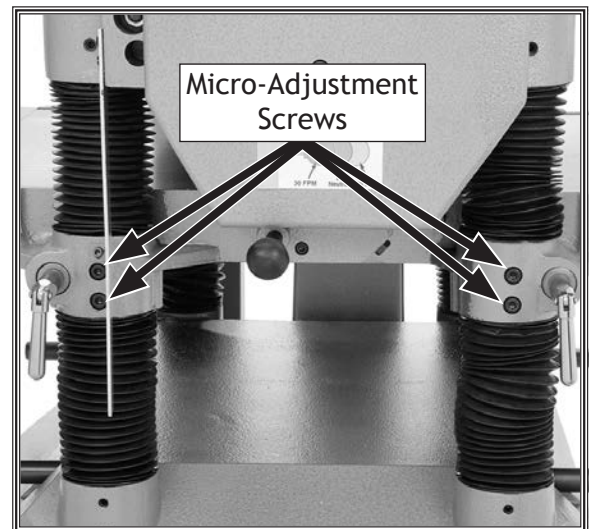
To adjust table parallelism, do these steps:

1. DISCONNECT MACHINE FROM POWER!
2. Remove motor access panel and locate chain on underside of table.
3. Loosen lock bolts and idler sprocket (see **Tensioning Table Height Chain Tension** instructions on **Page 50**).
4. Move chain away from sprocket you want to adjust so only that sprocket can be rotated independent of chain.

*Note: If the left side of the table is too high, the left two sprockets will need to be adjusted. Each tooth on the sprocket represents .016" of vertical movement as the cogs are turned. Make sure, as you turn the sprockets, to keep an accurate tooth count to ensure that the table is adjusted equally.*

5. Mark location of one tooth of sprocket that you are adjusting.
6. Carefully rotate sprocket (clockwise to lower table; counterclockwise to raise table) just enough to position next tooth at marked location, then fit chain around sprocket again.
7. Repeat **Steps 4-6** with each sprocket that needs to be adjusted until table-to-cutterhead clearance is within 0.016" from one side to the other.
8. Make sure chain is properly fitted on sprockets, then re-tighten idler sprocket and lock bolts.
9. If necessary, micro-adjust table position by loosening cap screws shown in **Figure 63** and raising or lowering table until it is properly aligned with cutterhead.

*Note: This process may require adjusting the columns on both the left and right hand sides until you find the correct combination.*

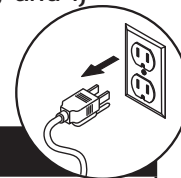


**Figure 63.** Location of table micro-adjustment screws (one side shown only).

# Troubleshooting

The following troubleshooting tables cover common problems that may occur with this machine. If you need replacement parts or additional troubleshooting help, contact our Technical Support.

**Note:** Before contacting Tech Support, find the machine serial number and manufacture date, and if available, your original purchase receipt. This information is required to properly assist you.



## Motor and Electrical

PROBLEM	POSSIBLE CAUSE	CORRECTIVE ACTION
Machine does not start, or power supply breaker trips immediately after startup.	<ol style="list-style-type: none"> <li>1. STOP button depressed/at fault.</li> <li>2. Incorrect power supply voltage or circuit size.</li> <li>3. Thermal overload relay has tripped.</li> <li>4. Power supply circuit breaker tripped or fuse blown.</li> <li>5. Motor wires connected incorrectly.</li> <li>6. Wiring open/has high resistance.</li> <li>7. START button switch at fault.</li> <li>8. Start capacitor at fault.</li> <li>9. Thermal overload relay has tripped.</li> <li>10. Contactor not energized; has poor contacts.</li> <li>11. Centrifugal switch/contact points at fault.</li> <li>12. Motor at fault.</li> </ol>	<ol style="list-style-type: none"> <li>1. Rotate button head to reset; replace if at fault.</li> <li>2. Ensure correct power supply voltage and circuit size.</li> <li>3. Reset; adjust trip load dial if necessary; replace.</li> <li>4. Ensure circuit is sized correctly and free of shorts. Reset circuit breaker or replace fuse.</li> <li>5. Correct motor wiring connections.</li> <li>6. Check/fix broken, disconnected, or corroded wires.</li> <li>7. Replace switch.</li> <li>8. Test/replace if at fault.</li> <li>9. Reset; adjust trip load dial if necessary; replace.</li> <li>10. Test all legs for power/replace.</li> <li>11. Adjust/replace centrifugal switch/contact points if available.</li> <li>12. Test/repair/replace.</li> </ol>
Machine stalls or is underpowered.	<ol style="list-style-type: none"> <li>1. Machine undersized for task.</li> <li>2. Workpiece not suitable for machine.</li> <li>3. Motor overheated, causing thermal overload to trip.</li> <li>4. Belt(s) slipping; oil/grease on belt(s).</li> <li>5. Dull knives/inserts.</li> <li>6. Dust collection ducting problem.</li> <li>7. Motor wired incorrectly.</li> <li>8. Run capacitor at fault.</li> <li>9. Pulley slipping on shaft.</li> <li>10. Contactor not energized/has poor contacts.</li> <li>11. Centrifugal switch/contact points at fault.</li> <li>12. Motor bearings at fault.</li> </ol>	<ol style="list-style-type: none"> <li>1. Reduce feed rate/depth of cut.</li> <li>2. Only cut wood/ensure moisture is below 20%.</li> <li>3. Allow motor to cool, reset overload if necessary, and reduce depth of cut.</li> <li>4. Clean/tension/replace belt(s) (<b>Page 41</b>); align pulleys (<b>Page 42</b>).</li> <li>5. Sharpen/replace knives (<b>Page 31</b>), or replace inserts (<b>Page 34</b>).</li> <li>6. Clear blockages, seal leaks, use smooth wall duct, eliminate bends, close other branches.</li> <li>7. Wire motor correctly.</li> <li>8. Test/repair/replace.</li> <li>9. Tighten loose pulley; replace pulley/shaft if damaged.</li> <li>10. Test all legs for power/replace.</li> <li>11. Adjust/replace centrifugal switch/contact points if available.</li> <li>12. Test/repair/replace.</li> </ol>
Machine has vibration or noisy operation.	<ol style="list-style-type: none"> <li>1. Motor or component loose.</li> <li>2. V-belt(s) worn, loose, or slapping cover.</li> <li>3. Pulley loose.</li> <li>4. Bed rollers protruding unevenly.</li> <li>5. Plastic chip deflector hitting knives.</li> <li>6. Motor fan rubbing on fan cover.</li> <li>7. Knives/gibs at fault.</li> <li>8. Cutterhead bearings at fault.</li> <li>9. Centrifugal switch/contact points at fault.</li> <li>10. Motor bearings at fault.</li> </ol>	<ol style="list-style-type: none"> <li>1. Inspect/tighten loose bolts/nuts; replace damaged components.</li> <li>2. Tension/replace belts as a matched set (<b>Page 41</b>).</li> <li>3. Re-align/replace shaft, pulley set screw, and key.</li> <li>4. Adjust bed rollers (<b>Page 29</b>).</li> <li>5. Adjust chip deflector (<b>Page 48</b>); replace if necessary.</li> <li>6. Fix/replace fan cover; replace loose/damaged fan.</li> <li>7. Sharpen/replace knives; set knife alignment/height correctly (<b>Page 31</b>).</li> <li>8. Replace bearing(s).</li> <li>9. Adjust/replace centrifugal switch/contact points if available.</li> <li>10. Test by rotating shaft; rotational grinding/loose shaft requires bearing replacement.</li> </ol>

## Machine Operation

PROBLEM	POSSIBLE CAUSE	CORRECTIVE ACTION
<p>Excessive snipe (gouge in end of board that is uneven with rest of cut).</p> <p>Note: A small amount of snipe is inevitable with all types of planers. The key is minimizing it as much as possible.</p>	<ol style="list-style-type: none"> <li>One or both of bed rollers are set too high.</li> <li>Outfeed extension slopes down or is not level with main table.</li> <li>Chip breaker set too low.</li> <li>Workpiece is not supported as it leaves planer.</li> <li>Some snipe is inevitable.</li> </ol>	<ol style="list-style-type: none"> <li>Lower bed rollers (<b>Page 29</b>).</li> <li>Shim outfeed extension wing level with main table.</li> <li>Raise height of chip breaker (<b>Page 43</b>).</li> <li>Hold workpiece up slightly as it leaves outfeed end of planer.</li> <li>Plane lumber longer than your intended workpiece length, then cut off excess after planing complete.</li> </ol>
<p>Workpiece stops/slow in middle of cut.</p>	<ol style="list-style-type: none"> <li>Taking too heavy of a cut.</li> <li>One or both of bed rollers are set too low or too high.</li> <li>Chip breaker or pressure bar set too low.</li> <li>Feed rollers set too low or too high.</li> <li>Pitch and glue buildup on planer components.</li> </ol>	<ol style="list-style-type: none"> <li>Take a lighter cut.</li> <li>Adjust bed rollers (<b>Page 29</b>).</li> <li>Raise height of chip breaker or pressure bar (<b>Page 43</b>).</li> <li>Adjust feed rollers (<b>Page 43</b>).</li> <li>Clean internal cutterhead components with a pitch/resin-dissolving solvent.</li> </ol>
<p>Chipping (consistent pattern).</p>	<ol style="list-style-type: none"> <li>Knots or conflicting grain direction in wood.</li> <li>Taking too deep of a cut.</li> <li>Feeding workpiece too fast.</li> <li>Mis-adjusted chip breaker.</li> <li>Nicked or chipped knife/insert.</li> </ol>	<ol style="list-style-type: none"> <li>Inspect workpiece for knots and grain direction; only use clean stock, and cut WITH the grain.</li> <li>Take a smaller depth of cut. (Reduce cutting depth when planing hard woods.)</li> <li>Slow down feed rate.</li> <li>Adjust both sides of chip breaker to correct height.</li> <li>Replace affected knife (<b>Page 31</b>), or have it sharpened; rotate/replace insert (<b>Page 34</b>).</li> </ol>
<p>Chipping/indentation in workpiece surface (inconsistent pattern).</p>	<ol style="list-style-type: none"> <li>Chips aren't being properly expelled from cutterhead.</li> <li>Chip breaker not set correctly.</li> </ol>	<ol style="list-style-type: none"> <li>Use a proper dust-collection system.</li> <li>Correctly adjust chip breaker (<b>Page 43</b>).</li> </ol>
<p>Fuzzy grain.</p>	<ol style="list-style-type: none"> <li>Wood may have high moisture content or surface wetness.</li> <li>Dull knives/inserts.</li> </ol>	<ol style="list-style-type: none"> <li>Check moisture content is below 20% and allow to dry if moisture is too high.</li> <li>Replace knives (<b>Page 31</b>) or have them professionally sharpened; rotate/replace inserts (<b>Page 34</b>).</li> </ol>
<p>Long lines or ridges that run along length of board.</p>	<ol style="list-style-type: none"> <li>Nicked or chipped knife/inserts.</li> </ol>	<ol style="list-style-type: none"> <li>Replace knives (<b>Page 31</b>) or have them professionally sharpened; rotate/replace inserts (<b>Page 34</b>).</li> </ol>
<p>Uneven cutting marks, wavy surface, or chatter marks across face of board.</p>	<ol style="list-style-type: none"> <li>Feeding workpiece too fast.</li> <li>Chip breaker or pressure bar set unevenly or not low enough.</li> <li>Knives not installed evenly/inserts not properly installed.</li> <li>Worn cutterhead bearings.</li> </ol>	<ol style="list-style-type: none"> <li>Slow down feed rate.</li> <li>Adjust height of chip breaker (<b>Page 43</b>).</li> <li>Adjust knives with knife gauge (<b>Page 31</b>); remove inserts, properly clean mounting pocket and re-install (<b>Page 34</b>).</li> <li>Replace cutterhead bearings.</li> </ol>
<p>Glossy surface.</p>	<ol style="list-style-type: none"> <li>Knives/inserts are dull.</li> <li>Feeding workpiece too slow.</li> <li>Cutting depth too shallow.</li> </ol>	<ol style="list-style-type: none"> <li>Replace knives (<b>Page 31</b>) or have them professionally sharpened; rotate/replace inserts (<b>Page 34</b>).</li> <li>Increase feed rate.</li> <li>Increase depth of cut.</li> </ol>
<p>If workpiece twists in machine.</p>	<ol style="list-style-type: none"> <li>Feed rollers not parallel with table.</li> </ol>	<ol style="list-style-type: none"> <li>Adjust feed rollers (<b>Page 43</b>).</li> </ol>

# Electrical Safety Instructions

These pages are current at the time of printing. However, in the spirit of improvement, we may make changes to the electrical systems of future machines. Compare the manufacture date of your machine to the one stated in this manual, and study this section carefully.

If there are differences between your machine and what is shown in this section, call Technical Support at (360) 734-3482 for assistance **BEFORE** making any changes to the wiring on your machine. An updated wiring diagram may be available. **Note:** *Please gather the serial number and manufacture date of your machine before calling. This information can be found on the main machine label.*

## WARNING

**SHOCK HAZARD.** Working on wiring that is connected to a power source is extremely dangerous. Touching electrified parts will result in personal injury including but not limited to severe burns, electrocution, or death. Disconnect the power from the machine before servicing electrical components!

**QUALIFIED ELECTRICIAN.** Due to the inherent hazards of electricity, only a qualified electrician should perform wiring tasks on this machine. If you are not a qualified electrician, get help from one before attempting any kind of wiring job.

**WIRE CONNECTIONS.** All connections must be tight to prevent wires from loosening during machine operation. Double-check all wires disconnected or connected during any wiring task to ensure tight connections.

**WIRE/COMPONENT DAMAGE.** Damaged wires or components increase the risk of serious personal injury, fire, or machine damage. If you notice that any wires or components are damaged while performing a wiring task, replace those wires or components before completing the task.

**MODIFICATIONS.** Using aftermarket parts or modifying the wiring beyond what is shown in the diagram may lead to unpredictable results, including serious injury or fire.

**MOTOR WIRING.** The motor wiring shown in these diagrams is current at the time of printing, but it may not match your machine. Always use the wiring diagram inside the motor junction box.

**CAPACITORS/INVERTERS.** Some capacitors and power inverters store an electrical charge for up to 10 minutes after being disconnected from the power source. To reduce the risk of being shocked, wait at least this long before working on capacitors.

**CIRCUIT REQUIREMENTS.** You **MUST** follow the requirements at the beginning of this manual when connecting your machine to a power source.

**EXPERIENCING DIFFICULTIES.** If you are experiencing difficulties understanding the information included in this section, contact our Technical Support at (360) 734-3482.

### NOTICE

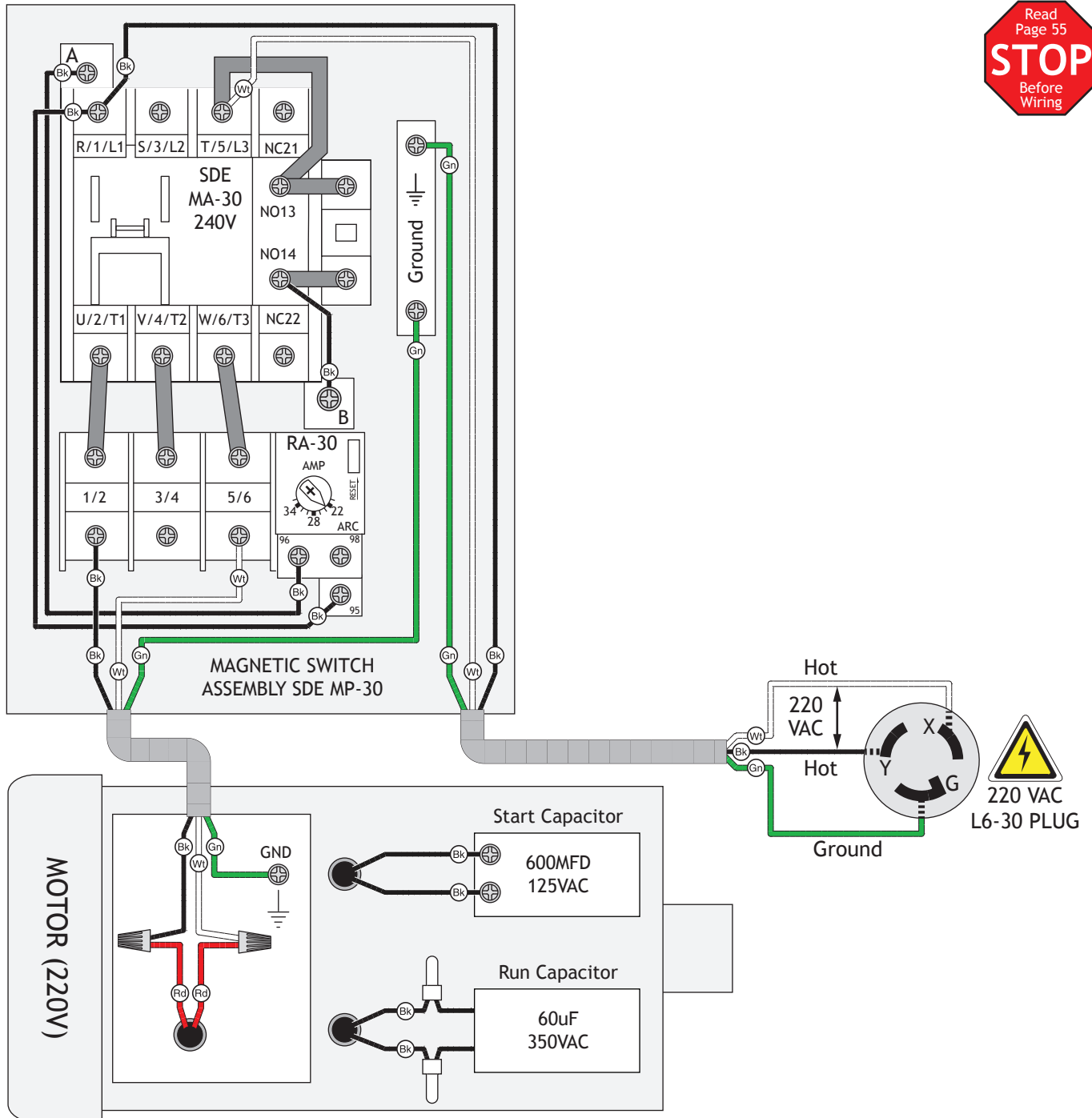
The photos and diagrams included in this section are best viewed in color. You can view these pages in color at [www.shopfox.biz](http://www.shopfox.biz).

### WIRING DIAGRAM COLOR KEY

BLACK	BLUE	YELLOW	LIGHT BLUE
WHITE	BROWN	YELLOW GREEN	BLUE WHITE
GREEN	GRAY	PURPLE	TUR-QUOISE
RED	ORANGE	PINK	



# W1864 Wiring Diagram



SERVICE

**NOTICE**  
This motor wiring diagram is current at the time of printing; however, always use the diagram on the inside of the junction box cover when rewiring your motor!

# W1864 Electrical Components



Figure 64. W1864 magnetic switch with cover removed.

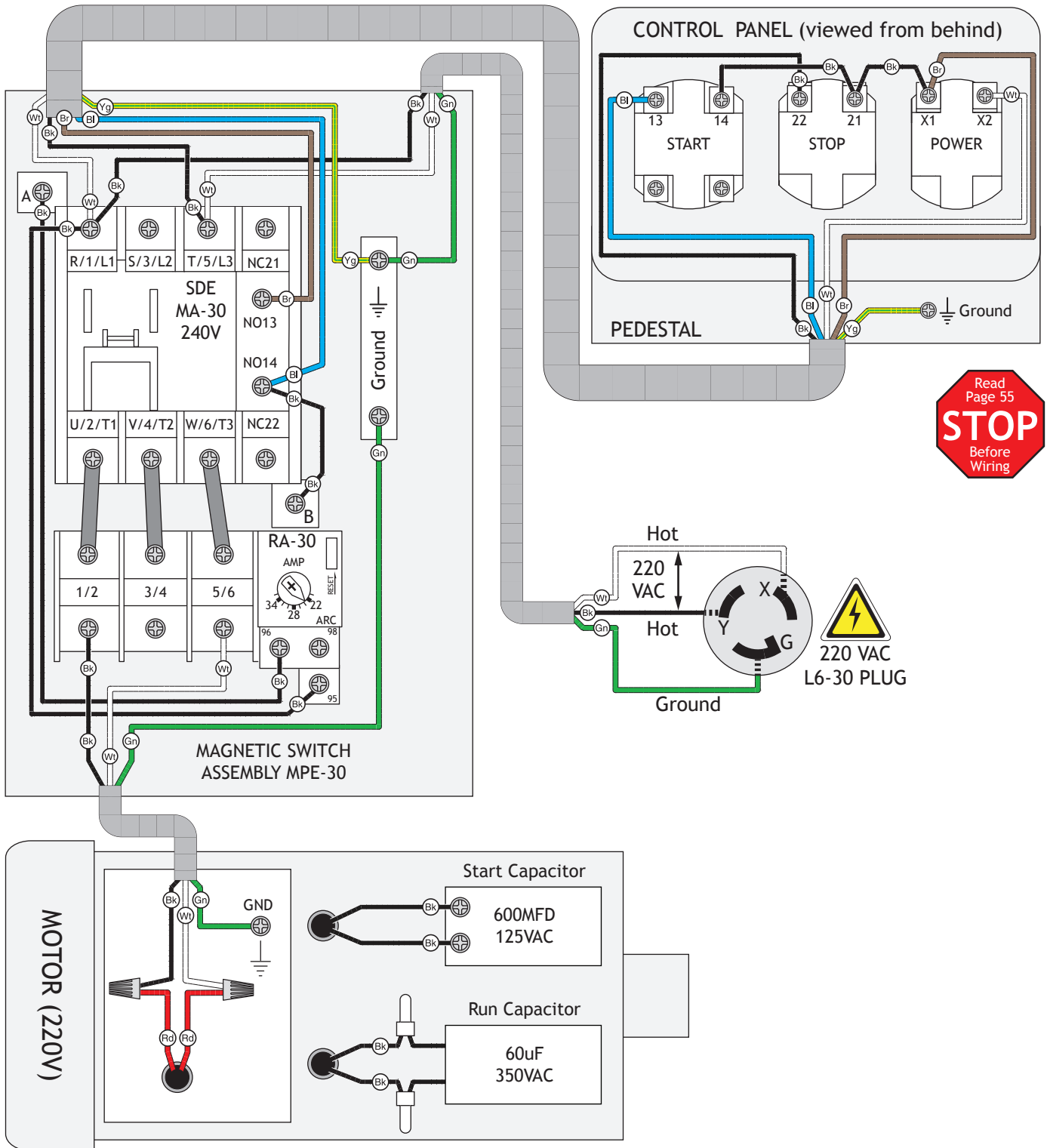


Figure 65. W1864 motor junction box.



Figure 66. W1864 capacitors.

# W1865 Wiring Diagram



**NOTICE**  
This motor wiring diagram is current at the time of printing; however, always use the diagram on the inside of the junction box cover when rewiring your motor!

SERVICE



# W1865 Electrical Components



Figure 67. W1865 magnetic switch with cover removed.



Figure 69. W1865 motor junction box.

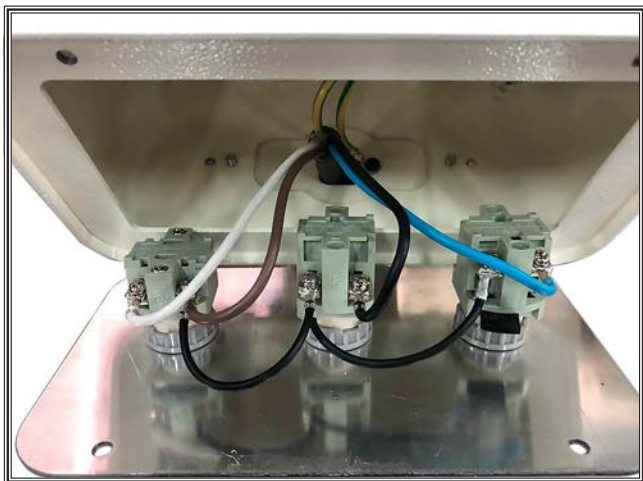


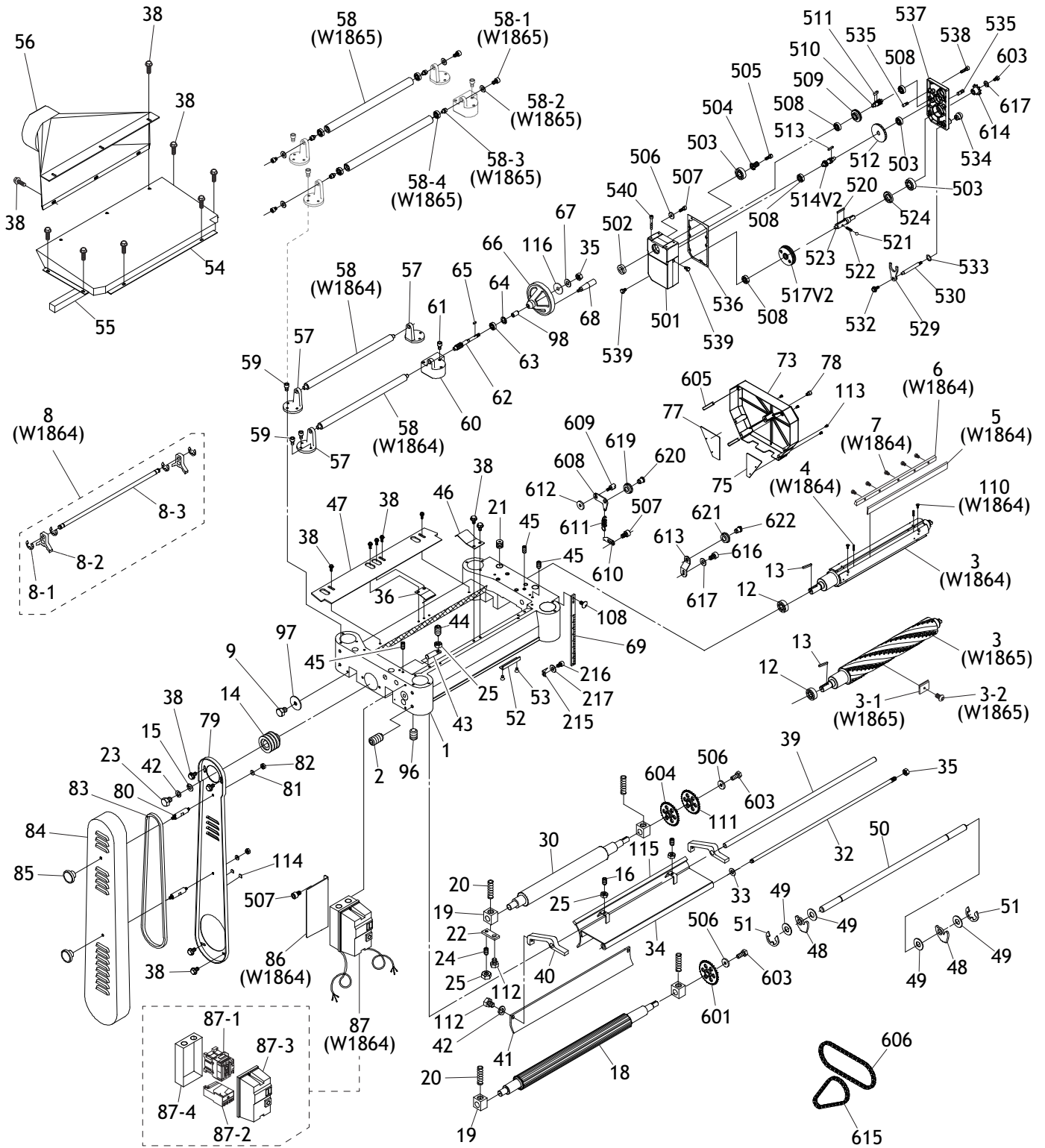
Figure 68. W1865 control panel.



Figure 70. W1865 capacitors.

# PARTS

## Main



PARTS

# Main Parts List

REF PART #	DESCRIPTION	REF PART #	DESCRIPTION		
1	X1864001	HEADSTOCK CASTING	54	X1864054	UPPER COVER
2	X1864002	SET SCREW M10-1.5 X 12	55	X1864055	UPPER COVER GASKET
3	X1864003	CUTTERHEAD 20" 4-KNIFE (W1864)	56	X1864056	DUST PORT 5"
3A	X1864003A	CUTTERHEAD ASSEMBLY 20" 4-KNIFE (W1864)	57	X1864057	RETURN ROLLER BRACKET
3	X1865003	HELICAL CUTTERHEAD 20" (W1865)	58	X1864058	RETURN ROLLER (W1864)
3A	X1865003A	HELICAL CUTTERHEAD ASSEMBLY 20" (W1865)	58	X1865058	RETURN ROLLER (W1865)
3-1	X1865003-1	INSERTS 15 X 15 X 2.5 (10 PK) (W1865)	58-1	X1865058-1	CAP SCREW M6-1 X 10 (W1865)
3-2	X1865003-2	FLAT HD TORX 10-32 X 1/2 (W1865)	58-2	X1865058-2	FLAT WASHER 6MM (W1865)
4	X1864004	COMPRESSION SPRING 0.6 X 5.9 X 16 (W1864)	58-3	X1865058-3	BEARING SHAFT (W1865)
5	X1864005	20" PLANER KNIVES-SET OF 4 (W1864)	58-4	X1865058-4	BALL BEARING 620ZZZ (W1865)
6	X1864006	CUTTERHEAD GIB (W1864)	59	X1864059	CAP SCREW M6-1 X 16
7	X1864007	HEX BOLT M8-1.25 X 10 (W1864)	60	X1864060	WORM GEAR HOUSING
8	X1864008	KNIFE-SETTING JIG ASSEMBLY (W1864)	61	X1864061	CAP SCREW M6-1 X 50
8-1	X1864008-1	E-CLIP 9MM (W1864)	62	X1864062	WORM SHAFT
8-2	X1864008-2	KNIFE-SETTING JIG FOOT (W1864)	63	X1864063	BALL BEARING 6201-2RS
8-3	X1864008-3	KNIFE-SETTING JIG SHAFT (W1864)	64	X1864064	INT RETAINING RING 32MM
9	X1864009	HEX BOLT M6-1 X 12	65	X1864065	KEY 4 X 4 X 10
12	X1864012	BALL BEARING 6206-2RS	66	X1864066	HANDWHEEL TYPE-2 200D X 12B-K X 3/8-16
13	X1864013	KEY 8 X 8 X 36	67	X1864067	FLAT WASHER 13MM
14	X1864014	CUTTERHEAD PULLEY	68	X1864068	REVOLVING HANDLE 1 X 3-9/16, 3/8-16 X 1/2
15	X1864015	FENDER WASHER 8MM	69	X1864069	SCALE
16	X1864016	SET SCREW M6-1 X 12	73	X1864073	DRIVE CHAIN COVER
18	X1864018	INFEED ROLLER	75	X1864075	GEARBOX COVER PLATE-A
19	X1864019	BUSHING BLOCK	77	X1864077	GEARBOX COVER PLATE-B
20	X1864020	COMPRESSION SPRING 3.5 X 19.7 X 70	78	X1864078	CAP SCREW M8-1.25 X 10
21	X1864021	TENSIONING SET SCREW M22-1.5 X 20	79	X1864079	PULLEY GUARD
22	X1864022	BUSHING BLOCK PLATE	80	X1864080	STANDOFF-HEX DE
23	X1864023	HEX BOLT M8-1.25 X 30	81	X1864081	FLAT WASHER 5/16
24	X1864024	SET SCREW M6-1 X 16	82	X1864082	HEX NUT 5/16-18
25	X1864025	HEX NUT M6-1 THIN	83	X1864083	V-BELT M58 3L580
30	X1864030	OUTFEED ROLLER	84	X1864084	PULLEY COVER
32	X1864032	CHIP BREAKER PIVOT ROD M12-1.75 X 25	85	X1864085	KNOB 5/16-18, D1-3/4, ROUND
33	X1864033	EXT RETAINING RING 12MM	86	X1864086	SWITCH BRACKET (W1864)
34	X1864034	CHIP BREAKER	87	X1864087	MAGNETIC SWITCH ASSY SDE MP-30
35	X1864035	HEX NUT M12-1.75	87-1	X1864087-1	CONTACTOR SDE MA-30 220-240V
36	X1864036	FLAT SPRING 84 X 46 X 0.6MM	87-2	X1864087-2	OL RELAY SDE RA-30 22-34A
38	X1864038	FLANGE BOLT M6-1 X 12	87-3	X1864087-3	MAGNETIC SWITCH COVER (FRONT)
39	X1864039	CHIPBREAKER ADJUSTMENT ROD	87-4	X1864087-4	MAGNETIC SWITCH COVER (REAR)
40	X1864040	CHIPBREAKER ADJUSTMENT BRACKET	96	X1864096	SET SCREW M8-1.25 X 12
41	X1864041	PRESSURE BAR	97	X1864097	FENDER WASHER 6MM
42	X1864042	LOCK WASHER 8MM	98	X1864098	SLEEVE 13.5 ID X 30 L
43	X1864043	SHAFT	108	X1864108	PHLP HD SCR M6-1 X 12
44	X1864044	SET SCREW M6-1 X 20	110	X1864110	FLAT HD CAP SCR M5-.8 X 10 (W1864)
45	X1864045	SET SCREW M6-1 X 16	111	X1864111	SPROCKET 31T
46	X1864046	FLAT SPRING 84 X 46 X 0.6MM	112	X1864112	FLANGE BOLT M8-1.25 X 20
47	X1864047	CHIP DEFLECTOR	113	X1864113	PHLP HD SCR M4-.7 X 8
48	X1864048	ANTI-KICKBACK FINGER	114	X1864114	PULLEY GUARD PLATE
49	X1864049	SPACER	115	X1864115	CHIP BREAKER GASKET
50	X1864050	ANTI-KICKBACK SHAFT	116	X1864116	LOW/HIGH DIRECTION LABEL
51	X1864051	E-CLIP 15MM	215	X1864215	POINTER
52	X1864052	DEPTH LIMITER	216	X1864216	CAP SCREW M5-.8 X 10
53	X1864053	FLAT HD SCR M5-.8 X 12	217	X1864217	LOCK WASHER 5MM

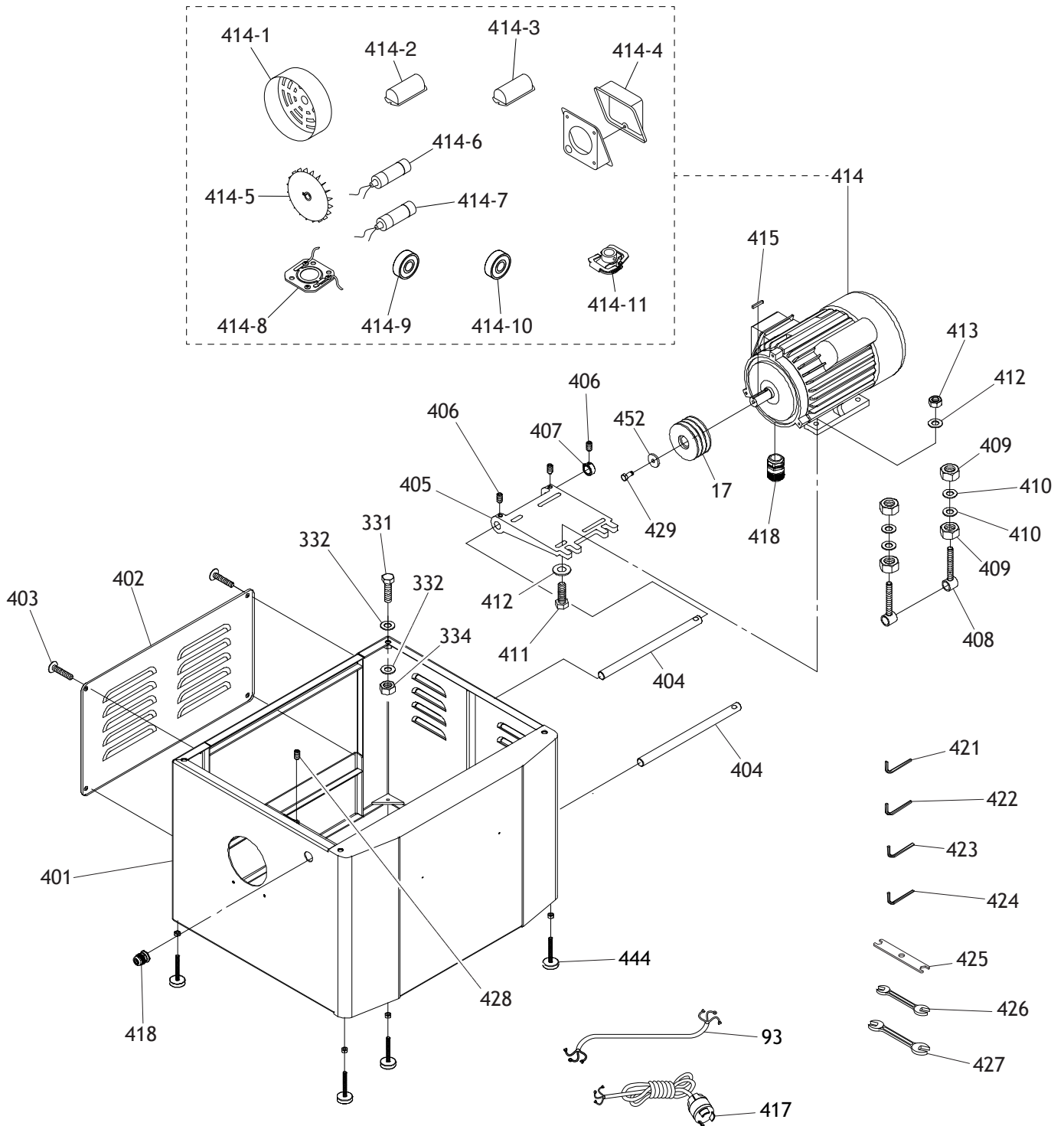


# Main Parts List (Cont.)

REF	PART #	DESCRIPTION
501	X1864501	GEARBOX
502	X1864502	OIL SEAL 28 X 40 X 8
503	X1864503	BALL BEARING 6204ZZ
504	X1864504	GEAR 16T
505	X1864505	CAP SCREW M6-1 X 25
506	X1864506	FENDER WASHER 6 X 20 X 3MM
507	X1864507	CAP SCREW M6-1 X 12
508	X1864508	BALL BEARING 6201ZZ
509	X1864509	GEAR 47T
510	X1864510	GEARED SHAFT 18T
511	X1864511	KEY 5 X 5 X 12
512	X1864512	GEAR 71T
513	X1864513	KEY 5 X 5 X 10
514V2	X1864514V2	GEARED SHAFT 28T/18T V2.02.19
517V2	X1864517V2	COMBO GEAR 86T/96T V2.02.19
520	X1864520	KEY 6 X 6 X 40
521	X1864521	STEEL BALL 6MM
522	X1864522	COMPRESSION SPRING 0.6 X 5.9 X 16
523	X1864523	GEAR SHAFT
524	X1864524	OIL SEAL 25 X 47 X 6
529	X1864529	SHIFTING FORK
530	X1864530	SHIFTING SHAFT
532	X1864532	FLANGE BOLT M6-1 X 12
533	X1864533	O-RING 12 X 1.5 S12.5
534	X1864534	KNOB 3/8-16, D1-1/4, BALL

REF	PART #	DESCRIPTION
535	X1864535	LOCATING PIN 8 X 7.55 X 7.95
536	X1864536	GASKET
537	X1864537	GEARBOX COVER
538	X1864538	CAP SCREW M6-1 X 25
539	X1864539	OIL PLUG 1/4 NPT X 3/4"
540	X1864540	CAP SCREW M8-1.25 X 50
601	X1864601	SPROCKET 31T
603	X1864603	HEX BOLT M6-1 X 16
604	X1864604	SPROCKET 31T
605	X1864605	ROLL PIN 6 X 20
606	X1864606	CHAIN 06B-1 X 67 33 LINKS
608	X1864608	CHAIN TENSIONER
609	X1864609	SHOULDER BOLT M8-1.25 X 14, 12 X 4
610	X1864610	SPRING BRACKET
611	X1864611	EXTENSION SPRING 1 X 8.5 X 33
612	X1864612	FLAT WASHER 8 X 22 X 3MM
613	X1864613	OUTER CHAIN TENSIONER
614	X1864614	SPROCKET 12T W/KEY
615	X1864615	CHAIN 06B-1 25 LINKS
616	X1864616	CAP SCREW M6-1 X 35
617	X1864617	FLAT WASHER 6MM
619	X1864619	CHAIN TENSIONER IDLER WHEEL
620	X1864620	CHAIN TENSIONER IDLER SHAFT
621	X1864621	OUTER CHAIN TENSIONER IDLER WHEEL
622	X1864622	OUTER CHAIN TENSIONER IDLER SHAFT

# W1864 Stand & Motor

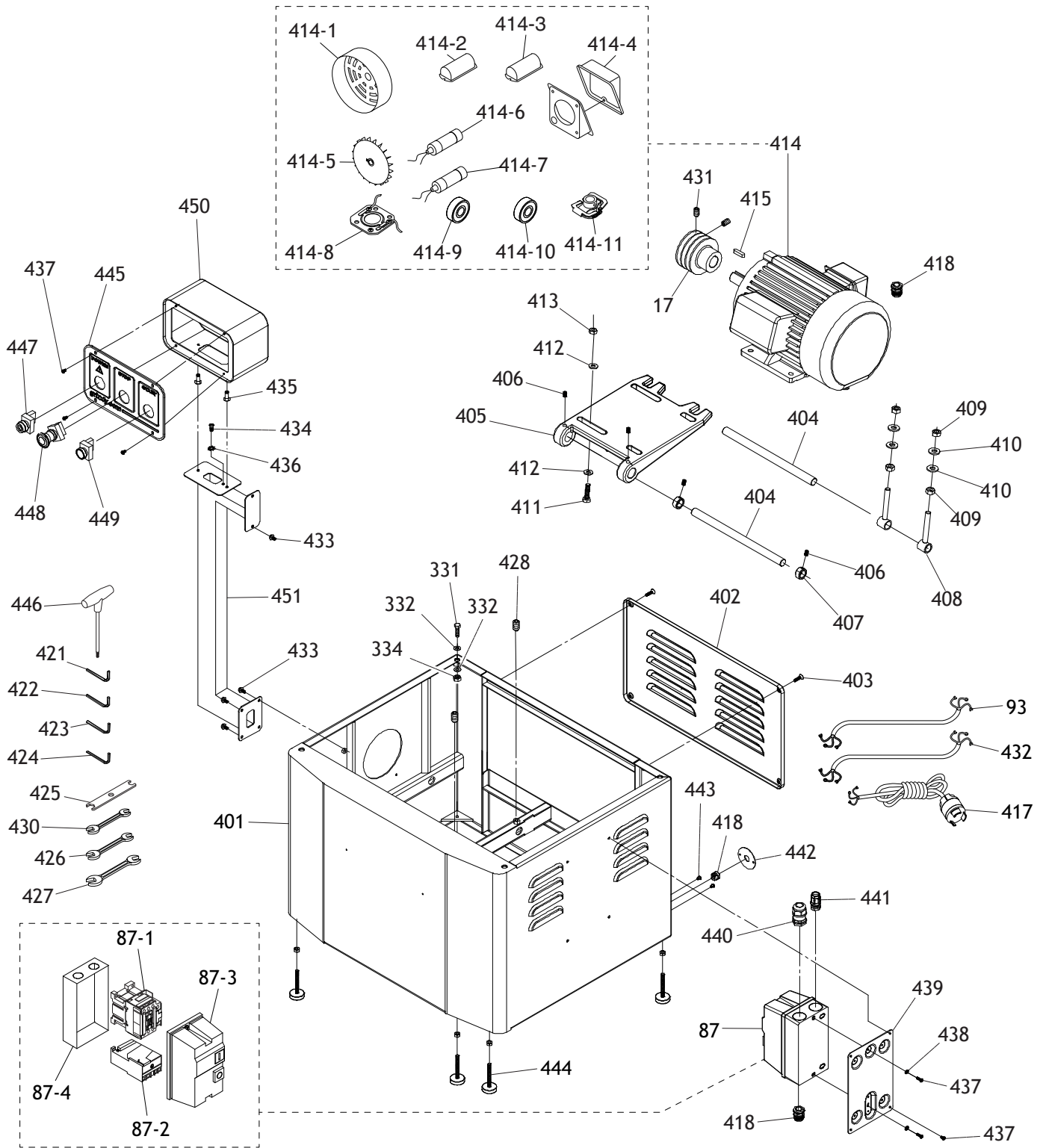


# W1864 Stand & Motor Parts List

REF	PART #	DESCRIPTION
17	X1864017	MOTOR PULLEY
93	X1864093	MOTOR CORD 10G 3W 57"
331	X1864331	HEX BOLT M12-1.75 X 50
332	X1864332	FLAT WASHER 12MM
334	X1864334	HEX NUT M12-1.75
401	X1864401	STAND
402	X1864402	MOTOR ACCESS PANEL
403	X1864403	FLAT HD SCR M6-1 X 20
404	X1864404	PLATE CONNECTING ROD
405	X1864405	MOTOR MOUNT PLATE
406	X1864406	SET SCREW M8-1.25 X 12
407	X1864407	COLLAR
408	X1864408	ROD END BOLT M12-1.75 X 105, ID 20MM
409	X1864409	HEX NUT M12-1.75
410	X1864410	FLAT WASHER 12MM
411	X1864411	HEX BOLT M8-1.25 X 40
412	X1864412	FLAT WASHER 8 X 22 X 3MM
413	X1864413	HEX NUT M8-1.25
414	X1864414	MOTOR 5HP 220V 1-PH
414-1	X1864414-1	MOTOR FAN COVER
414-2	X1864414-2	R CAPACITOR COVER
414-3	X1864414-3	S CAPACITOR COVER

REF	PART #	DESCRIPTION
414-4	X1864414-4	MOTOR JUNCTION BOX
414-5	X1864414-5	MOTOR FAN
414-6	X1864414-6	R CAPACITOR 60M 350V 1-3/4 X 4-5/16
414-7	X1864414-7	S CAPACITOR 600M 125V 1-3/4 X 3-5/16
414-8	X1864414-8	CONTACT PLATE
414-9	X1864414-9	BALL BEARING 6205ZZ (FRONT)
414-10	X1864414-10	BALL BEARING 6203ZZ (REAR)
414-11	X1864414-11	CENTRIFUGAL SWITCH
415	X1864415	KEY 5 X 5 X 30
417	X1864417	POWER CORD 10G 3W 138" L6-30P
418	X1864418	STRAIN RELIEF TYPE-3 M20-1.5
421	X1864421	HEX WRENCH 3MM
422	X1864422	HEX WRENCH 4MM
423	X1864423	HEX WRENCH 5MM
424	X1864424	HEX WRENCH 6MM
425	X1864425	FLAT WRENCH 10 X 13MM OPEN ENDS
426	X1864426	WRENCH 12 X 14MM OPEN ENDS
427	X1864427	WRENCH 17 X 19MM OPEN ENDS
428	X1864428	SET SCREW M8-1.25 X 16
429	X1864429	HEX BOLT M8-1.25 X 30
444	X1864444	ADJUSTABLE FOOT
452	X1864452	FENDER WASHER 8MM

# W1865 Stand & Motor

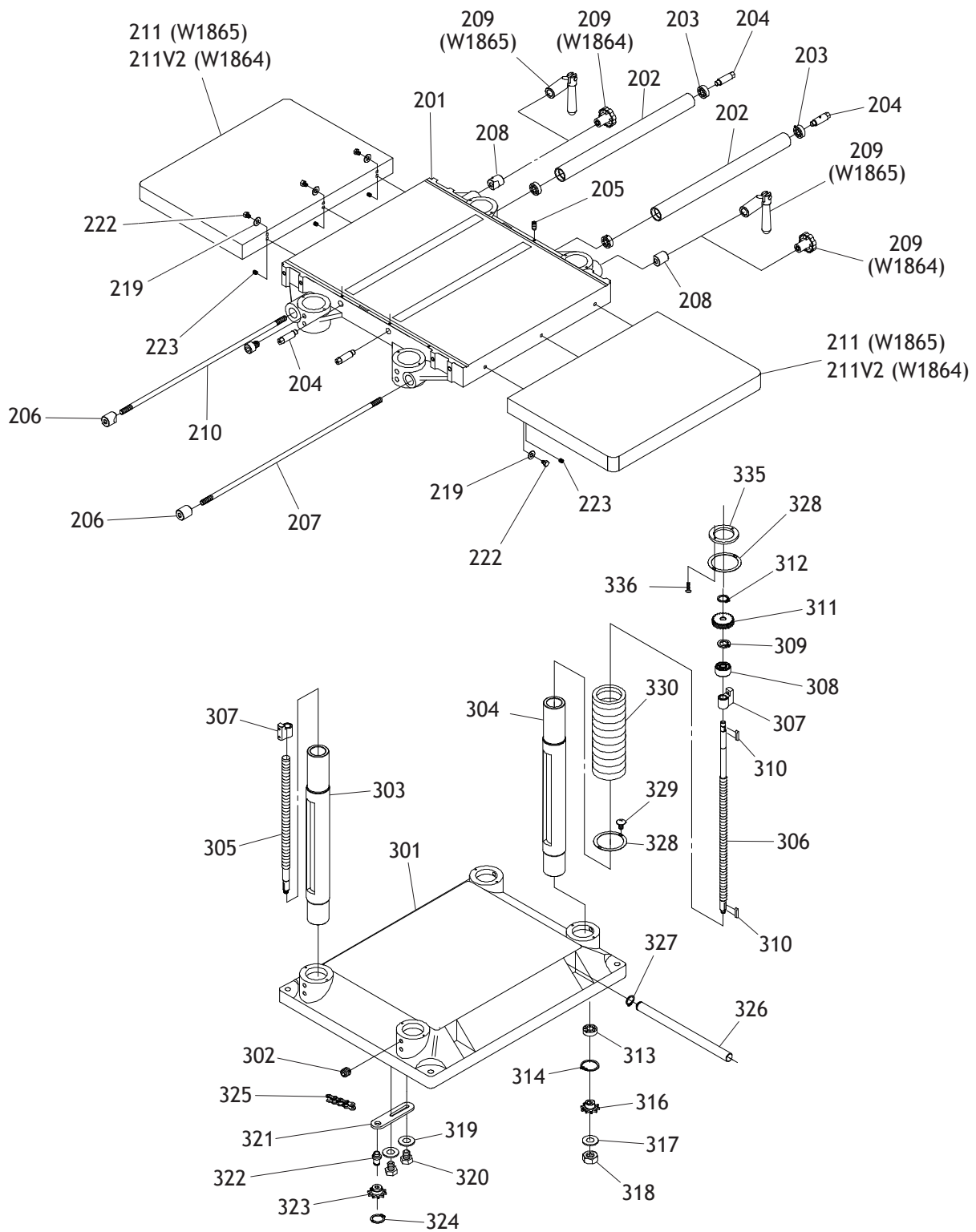


# W1865 Stand & Motor Parts List

REF	PART #	DESCRIPTION
17	X1865017	MOTOR PULLEY
87	X1865087	MAGNETIC SWITCH ASSY SDE MP-30
87-1	X1865087-1	CONTACTOR SDE MA-30 220-240V
87-2	X1865087-2	OL RELAY SDE RA-30 22-34A
87-3	X1865087-3	MAGNETIC SWITCH COVER (FRONT)
87-4	X1865087-4	MAGNETIC SWITCH COVER (REAR)
93	X1865093	MOTOR CORD 10G 3W 57"
331	X1865331	HEX BOLT M12-1.75 X 50
332	X1865332	FLAT WASHER 12MM
334	X1865334	HEX NUT M12-1.75
401	X1865401	STAND
402	X1865402	MOTOR ACCESS PANEL
403	X1865403	FLAT HD SCR M6-1 X 20
404	X1865404	PLATE CONNECTING ROD
405	X1865405	MOTOR MOUNT PLATE
406	X1865406	SET SCREW M8-1.25 X 12
407	X1865407	COLLAR
408	X1865408	ROD END BOLT M12-1.75 X 105, ID 20MM
409	X1865409	HEX NUT M12-1.75
410	X1865410	FLAT WASHER 12MM
411	X1865411	HEX BOLT M8-1.25 X 40
412	X1865412	FLAT WASHER 8 X 22 X 3MM
413	X1865413	HEX NUT M8-1.25
414	X1865414	MOTOR 5HP 220V 1-PH
414-1	X1865414-1	MOTOR FAN COVER
414-2	X1865414-2	R CAPACITOR COVER
414-3	X1865414-3	S CAPACITOR COVER
414-4	X1865414-4	MOTOR JUNCTION BOX
414-5	X1865414-5	MOTOR FAN
414-6	X1865414-6	R CAPACITOR 60M 350V 1-3/4 X 4-5/16
414-7	X1865414-7	S CAPACITOR 600M 125V 1-3/4 X 3-5/16
414-8	X1865414-8	CONTACT PLATE
414-9	X1865414-9	BALL BEARING 6205ZZ (FRONT)
414-10	X1865414-10	BALL BEARING 6203ZZ (REAR)

REF	PART #	DESCRIPTION
414-11	X1865414-11	CENTRIFUGAL SWITCH
415	X1865415	KEY 5 X 5 X 30
417	X1865417	POWER CORD 10G 3W 138" L6-30P
418	X1865418	STRAIN RELIEF TYPE-3 M25-1.5
421	X1865421	HEX WRENCH 3MM
422	X1865422	HEX WRENCH 4MM
423	X1865423	HEX WRENCH 5MM
424	X1865424	HEX WRENCH 6MM
425	X1865425	FLAT WRENCH 10 X 13MM OPEN ENDS
426	X1865426	WRENCH 12 X 14MM OPEN ENDS
427	X1865427	WRENCH 17 X 19MM OPEN ENDS
428	X1865428	SET SCREW M8-1.25 X 16
430	X1865430	WRENCH 8 X 10MM OPEN ENDS
431	X1865431	SET SCREW M8-1.25 X 20
432	X1865432	SWITCH CORD 18G 4W
433	X1865433	FLANGE BOLT M6-1 X 12
434	X1865434	PHLP HD SCR M4-.7 X 8
435	X1865435	HEX BOLT M5-.8 X 10
436	X1865436	EXT TOOTH WASHER 4MM
437	X1865437	PHLP HD SCR M5-.8 X 10
438	X1865438	EXT TOOTH WASHER 5MM
439	X1865439	SWITCH MOUNTING PLATE
440	X1865440	STRAIN RELIEF TYPE-3 PG21
441	X1865441	STRAIN RELIEF TYPE-3 PG16
442	X1865442	STRAIN RELIEF MOUNTING PLATE
443	X1865443	PHLP HD SCR M6-1 X 8
444	X1865444	ADJUSTABLE FOOT
445	X1865445	SWITCH PANEL
446	X1865446	T-HANDLE TORX DRIVER T-25
447	X1865447	POWER INDICATOR LIGHT 220V 25MM RED
448	X1865448	E-STOP BUTTON RENEY R9C01VN
449	X1865449	START SWITCH
450	X1865450	SWITCH BOX
451	X1865451	SWITCH PEDESTAL

# Table & Base





## Table & Base Parts List

REF	PART #	DESCRIPTION
201	X1864201	MAIN TABLE
202	X1864202	MAIN TABLE ROLLER
203	X1864203	BALL BEARING 6201-2RS
204	X1864204	ECCENTRIC SHAFT
205	X1864205	SET SCREW M6-1 X 12
206	X1864206	THREADED GIB
207	X1864207	LOCKING ROD
208	X1864208	GIB
209	X1864209	KNOB M12-1.75, 6-LOBE, D53 (W1864)
209	X1865209	LOCK HANDLE M12-1.75 (W1865)
210	X1864210	CAP SCREW M8-1.25 X 16
211	X1865211	EXTENSION WING (W1865)
211V2	X1864211V2	EXTENSION WING V2.07.19 (W1864)
219	X1864219	FLAT WASHER 8MM
222	X1864222	HEX BOLT M8-1.25 X 25
223	X1864223	SET SCREW M8-1.25 X 12
301	X1864301	BASE
302	X1864302	SET SCREW M10-1.5 X 12
303	X1864303	COLUMN (SECONDARY)
304	X1864304	COLUMN (PRIMARY)
305	X1864305	LEADSCREW 19.05-4 X 321 (SECONDARY)
306	X1864306	LEADSCREW 19.05-4 X 335 (PRIMARY)
307	X1864307	LEADSCREW NUT 19.05-4
308	X1864308	SPACER

REF	PART #	DESCRIPTION
309	X1864309	INT RETAINING RING 38MM
310	X1864310	KEY 4 X 4 X 10
311	X1864311	GEAR 24T
312	X1864312	EXT RETAINING RING 12MM
313	X1864313	BALL BEARING 6202ZZ
314	X1864314	INT RETAINING RING 35MM
316	X1864316	SPROCKET 10T
317	X1864317	FLAT WASHER 10MM
318	X1864318	HEX NUT M10-1.25
319	X1864319	FLAT WASHER 8 X 22 X 3MM
320	X1864320	HEX BOLT M8-1.25 X 25
321	X1864321	IDLER BRACKET
322	X1864322	IDLER SHAFT
323	X1864323	SPROCKET 10T
324	X1864324	EXT RETAINING RING 15MM
325	X1864325	CHAIN #40 X 166
326	X1864326	LIFTING BAR
327	X1864327	EXT RETAINING RING 17MM
328	X1864328	DUST BOOT FLANGE
329	X1864329	TAP SCREW M5 X 10
330	X1864330	DUST BOOT
335	X1864335	DUST BOOT FLANGE RING
336	X1864336	TAP SCREW M5 X 16

# W1864 Labels & Cosmetics



Note: Similar headstock shown as example.

**701**

**WARNING**  
READ AND UNDERSTAND MANUAL: To avoid personal injury, if a manual is not available, GO HERE and manual instead, go to [www.shopfoxint.com](http://www.shopfoxint.com) or call (360) 734-3482.

**702V3**

**SHOP FOX**

**MODEL W1864**  
**20" 5HP PLANER**

**Specifications**

Motor: 5 HP, 230V, 1-Ph, 60 Hz  
Full-Load Current Rating: 23A  
Cutterhead: 4 Knives, 5-1/4" Dia.  
Replacement Knives: D3097  
Cutterhead Speed: 5000 RPM  
Feed Rates: 16 & 28 FPM  
Max. Depth of Cut: 3/32"  
Min. Stock Thickness: 1/4"  
Max. Stock Thickness: 8"  
Max. Stock Length: 7"  
Max. Cutting Width: 20"  
Weight: 740 lbs.

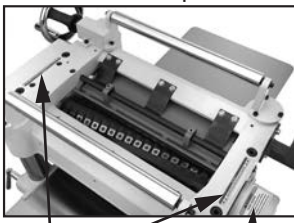
**WARNING!**

To reduce the risk of serious injury when using this machine:

1. Read and understand owner's manual before operating.
2. Always wear approved safety glasses and respirator.
3. Disconnect power before changing blades, removing parts, or doing maintenance, service, or adjustments.
4. Only plug power cord into a grounded outlet.
5. Do not wear loose clothing, gloves, jewelry, or other items that can get entangled. The back long hair and roll up sleeves.
6. Ensure machine is correctly set up before starting.
7. Do not plane two boards of varying thickness at same time.
8. Never plane material smaller than 6" long or 1/4" thick.
9. Keep fingers clear of pinch point between stock and table.
10. Stand clear of board ends during cutting operation.
11. Knives are sharp! Use extreme caution when servicing.
12. Never reach into cutting area while machine is running.
13. Do not expose to rain or use in damp or wet locations.
14. Prevent unauthorized use by children or untrained users.

**703**

**WARNING**  
ACCIDENTAL INJURY HAZARD!  
Disconnect power supply before adjustments, setup or maintenance!



**704**

**NOTICE**

← Add SAE 30 oil every 24 hours of operation. →



**706V2**

**NOTICE**

Only shift gearbox when planer is running.

**705**

**WARNING!**

**INJURY HAZARD!**  
To reduce the risk of serious personal injury, do not remove this cover while the machine is running or connected to power. Always disconnect power before servicing.

**713**

**WARNING**  
EYE/EAR/LUNG INJURY HAZARD!  
Always wear safety glasses, ear protection, and respirator when using this machine.

**712**

**W1864**  
707

**SHOP FOX**  
INTERNATIONAL  
708

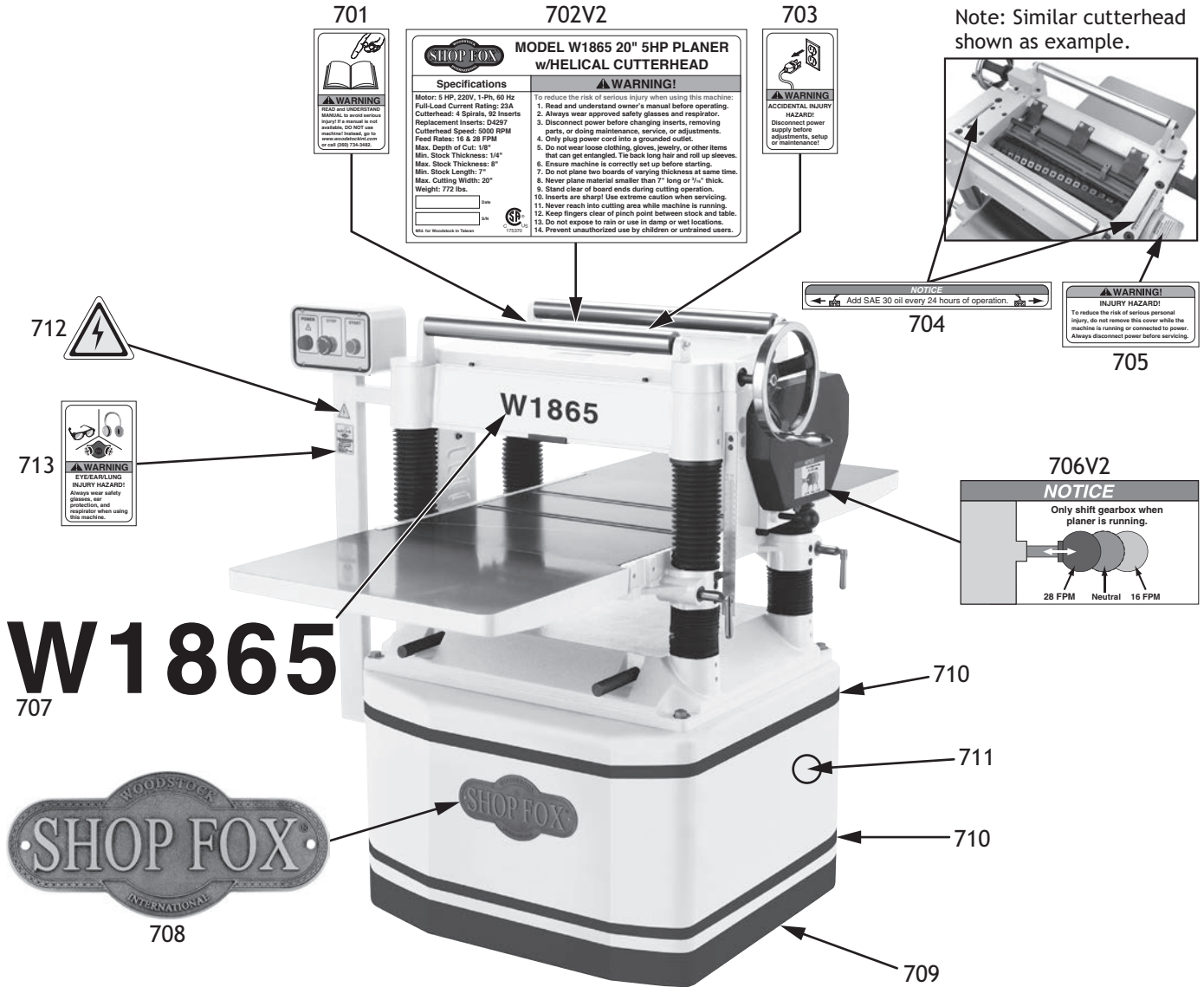
REF	PART #	DESCRIPTION
701	X1864701	READ MANUAL LABEL
702V3	X1864702V3	MACHINE ID LABEL V3.07.19
703	X1864703	DISCONNECT POWER LABEL
704	X1864704	ADD OIL NOTICE
705	X1864705	BELT COVER WARNING LABEL
706V2	X1864706V2	SHIFT GEARBOX NOTICE V2.02.19
707	X1864707	MODEL NUMBER LABEL

REF	PART #	DESCRIPTION
708	X1864708	SHOP FOX NAMEPLATE-MEDIUM
709	X1864709	BLACK STRIPE TAPE (LOWER)
710	X1864710	BLACK STRIPE TAPE (UPPER)
711	X1864711	TOUCH-UP PAINT, SHOP FOX WHITE
712	X1864712	ELECTRICITY LABEL
713	X1864713	EYE/EAR/LUNG INJURY LABEL

**! WARNING**

Safety labels warn about machine hazards and how to prevent serious personal injury. The owner of this machine **MUST** maintain the original location and readability of all labels on this machine. If any label is removed or becomes unreadable, **REPLACE** that label before allowing machine to be operated again. Contact us at (360) 734-3482 or [www.woodstockint.com](http://www.woodstockint.com) to order new labels.

# W1865 Labels & Cosmetics



# W1865

707



REF	PART #	DESCRIPTION
701	X1865701	READ MANUAL LABEL
702V2	X1865702V2	MACHINE ID LABEL V2.02.19
703	X1865703	DISCONNECT POWER LABEL
704	X1865704	ADD OIL NOTICE
705	X1865705	BELT COVER WARNING LABEL
706V2	X1865706V2	SHIFT GEARBOX NOTICE V2.02.19
707	X1865707	MODEL NUMBER LABEL

REF	PART #	DESCRIPTION
708	X1865708	SHOP FOX NAMEPLATE-MEDIUM
709	X1865709	BLACK STRIPE TAPE (LOWER)
710	X1865710	BLACK STRIPE TAPE (UPPER)
711	X1865711	TOUCH-UP PAINT, SHOP FOX WHITE
712	X1865712	ELECTRICITY LABEL
713	X1865713	EYE/EAR/LUNG INJURY LABEL

## ! WARNING

Safety labels warn about machine hazards and how to prevent serious personal injury. The owner of this machine **MUST** maintain the original location and readability of all labels on this machine. If any label is removed or becomes unreadable, **REPLACE** that label before allowing machine to be operated again. Contact us at (360) 734-3482 or [www.woodstockint.com](http://www.woodstockint.com) to order new labels.



# Warranty Registration

Name \_\_\_\_\_  
 Street \_\_\_\_\_  
 City \_\_\_\_\_ State \_\_\_\_\_ Zip \_\_\_\_\_  
 Phone # \_\_\_\_\_ Email \_\_\_\_\_ Invoice # \_\_\_\_\_  
 Model # \_\_\_\_\_ Serial # \_\_\_\_\_ Dealer Name \_\_\_\_\_ Purchase Date \_\_\_\_\_

The following information is given on a voluntary basis. It will be used for marketing purposes to help us develop better products and services. Of course, all information is strictly confidential.

- How did you learn about us?
 

<input type="checkbox"/> Advertisement	<input type="checkbox"/> Friend	<input type="checkbox"/> Local Store
<input type="checkbox"/> Mail Order Catalog	<input type="checkbox"/> Website	<input type="checkbox"/> Other:
- How long have you been a woodworker/metalworker?
 

<input type="checkbox"/> 0-2 Years	<input type="checkbox"/> 2-8 Years	<input type="checkbox"/> 8-20 Years	<input type="checkbox"/> 20+ Years
------------------------------------	------------------------------------	-------------------------------------	------------------------------------
- How many of your machines or tools are Shop Fox?
 

<input type="checkbox"/> 0-2	<input type="checkbox"/> 3-5	<input type="checkbox"/> 6-9	<input type="checkbox"/> 10+
------------------------------	------------------------------	------------------------------	------------------------------
- Do you think your machine represents a good value?  Yes  No
- Would you recommend Shop Fox products to a friend?  Yes  No
- What is your age group?
 

<input type="checkbox"/> 20-29	<input type="checkbox"/> 30-39	<input type="checkbox"/> 40-49
<input type="checkbox"/> 50-59	<input type="checkbox"/> 60-69	<input type="checkbox"/> 70+
- What is your annual household income?
 

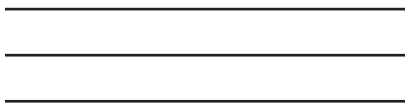
<input type="checkbox"/> \$20,000-\$29,000	<input type="checkbox"/> \$30,000-\$39,000	<input type="checkbox"/> \$40,000-\$49,000
<input type="checkbox"/> \$50,000-\$59,000	<input type="checkbox"/> \$60,000-\$69,000	<input type="checkbox"/> \$70,000+
- Which of the following magazines do you subscribe to?
 

<input type="checkbox"/> Cabinet Maker	<input type="checkbox"/> Popular Mechanics	<input type="checkbox"/> Today's Homeowner
<input type="checkbox"/> Family Handyman	<input type="checkbox"/> Popular Science	<input type="checkbox"/> Wood
<input type="checkbox"/> Hand Loader	<input type="checkbox"/> Popular Woodworking	<input type="checkbox"/> Wooden Boat
<input type="checkbox"/> Handy	<input type="checkbox"/> Practical Homeowner	<input type="checkbox"/> Woodshop News
<input type="checkbox"/> Home Shop Machinist	<input type="checkbox"/> Precision Shooter	<input type="checkbox"/> Woodsmith
<input type="checkbox"/> Journal of Light Cont.	<input type="checkbox"/> Projects in Metal	<input type="checkbox"/> Woodwork
<input type="checkbox"/> Live Steam	<input type="checkbox"/> RC Modeler	<input type="checkbox"/> Woodworker West
<input type="checkbox"/> Model Airplane News	<input type="checkbox"/> Rifle	<input type="checkbox"/> Woodworker's Journal
<input type="checkbox"/> Modeltec	<input type="checkbox"/> Shop Notes	<input type="checkbox"/> Other:
<input type="checkbox"/> Old House Journal	<input type="checkbox"/> Shotgun News	

9. Comments: \_\_\_\_\_  
 \_\_\_\_\_  
 \_\_\_\_\_  
 \_\_\_\_\_  
 \_\_\_\_\_

CUT ALONG DOTTED LINE

FOLD ALONG DOTTED LINE



Place  
Stamp  
Here



WOODSTOCK INTERNATIONAL INC.  
P.O. BOX 2309  
BELLINGHAM, WA 98227-2309



FOLD ALONG DOTTED LINE

TAPE ALONG EDGES--PLEASE DO NOT STAPLE

# WARRANTY

Woodstock International, Inc. warrants all Shop Fox machinery to be free of defects from workmanship and materials for a period of two years from the date of original purchase by the original owner. This warranty does not apply to defects due directly or indirectly to misuse, abuse, negligence or accidents, lack of maintenance, or reimbursement of third party expenses incurred.

Woodstock International, Inc. will repair, replace, or arrange for a dealer refund, at its expense and option, the Shop Fox machine or machine part proven to be defective for its designed and intended use, provided that the original owner returns the product prepaid to an authorized warranty or repair facility as designated by our Bellingham, Washington office with proof of their purchase of the product within two years, and provides Woodstock International, Inc. reasonable opportunity to verify the alleged defect through inspection. If it is determined there is no defect, or that the defect resulted from causes not within the scope of Woodstock International Inc.'s warranty, then the original owner must bear the cost of storing and returning the product.

This is Woodstock International, Inc.'s sole written warranty and any and all warranties that may be implied by law, including any merchantability or fitness, for any particular purpose, are hereby limited to the duration of this written warranty. We do not warrant that Shop Fox machinery complies with the provisions of any law, acts or electrical codes. We do not reimburse for third party repairs. In no event shall Woodstock International, Inc.'s liability under this limited warranty exceed the purchase price paid for the product, and any legal actions brought against Woodstock International, Inc. shall be tried in the State of Washington, County of Whatcom. We shall in no event be liable for death, injuries to persons or property or for incidental, contingent, special or consequential damages arising from the use of our products.

Every effort has been made to ensure that all Shop Fox machinery meets high quality and durability standards. We are committed to continuously improving the quality of our products, and reserve the right to change specifications at any time.





## High Quality Machines and Tools

Woodstock International, Inc. carries thousands of products designed to meet the needs of today's woodworkers and metalworkers.

Ask your dealer about these fine products:

**BROSMAN**  
PRECISION STOP BLOCK

**JOINTER PAL**<sup>®</sup>

**Rotacator**<sup>®</sup>

**STEELEX**<sup>®</sup>  
FINE TOOLS

**PLANER PAL**<sup>®</sup>

**THE REBEL**<sup>®</sup>

**PRO-STIK**<sup>®</sup>  
ABRASIVE BELT & DISC CLEANER

**BOARD BUDDIES**<sup>®</sup>

**WOODSTOCK**  
**SHOP FOX**<sup>®</sup>  
**INTERNATIONAL**

**STEELEX**<sup>®</sup>  
**PLUS**

**SLICKPLANE**<sup>®</sup>

*Aluma-Classic*<sup>®</sup>

**ACCU-SHARP**<sup>®</sup>

**ROMAN**  
**CARBIDE**<sup>®</sup>

**PARROT VISE**<sup>®</sup>

**WHOLESALE ONLY**

**WOODSTOCK INTERNATIONAL, INC.**

Phone: (360) 734-3482 • Fax: (360) 671-3053 • Toll Free Fax: (800) 647-8801

P.O.Box 2309 • Bellingham, WA 98227

**SHOPFOX.BIZ**