

READ THIS FIRST

Model W1859/W1860 ***IMPORTANT UPDATE***

Applies to Models Mfd. Since 11/20
and Owner's Manual Revised 6/20

Phone #: (360) 734-3482 • Tech Support: techsupport@woodstockint.com • Web: www.woodstockint.com



We made the following changes to this machine since the manual was printed:

- Infeed table lock warning added to **Adjusting Infeed Table Height** on Page 33.
- Infeed table lock warning label added to **Labels & Cosmetics** on Page 66.

Aside from the information contained in this update, all other content in the owner's manual is applicable and **MUST** be read and understood for your own safety.

IMPORTANT: Keep this update with the owner's manual for future reference. If you have any further questions, contact our Technical Support.

Adjusting Infeed Table Height

To adjust the infeed table height, loosen the infeed table lock (see **Figure 24**), move the infeed table adjustment lever (see **Figure 24**) up or down to raise or lower the table, and then tighten the lock to secure the setting.

To lower the infeed table below $\frac{1}{8}$ " stop, pull the table release knob (see **Figure 24**), adjust the table height, and then tighten the lock to secure the setting.

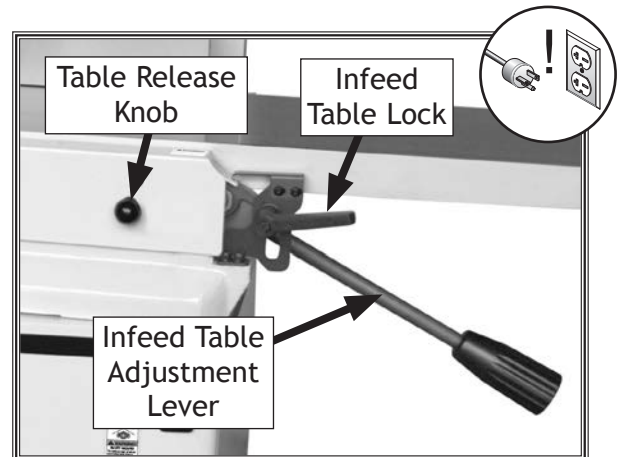

Figure 24. Infeed table controls.

⚠️ WARNING

Always secure infeed table lock before cutting. Table movement during jointer operation may lead to serious injury.

COPYRIGHT © NOVEMBER, 2020 BY WOODSTOCK INTERNATIONAL, INC.

WARNING: NO PORTION OF THIS MANUAL MAY BE REPRODUCED IN ANY SHAPE OR FORM WITHOUT

#21476AI

THE WRITTEN APPROVAL OF WOODSTOCK INTERNATIONAL, INC.

Printed in Taiwan

Labels & Cosmetics

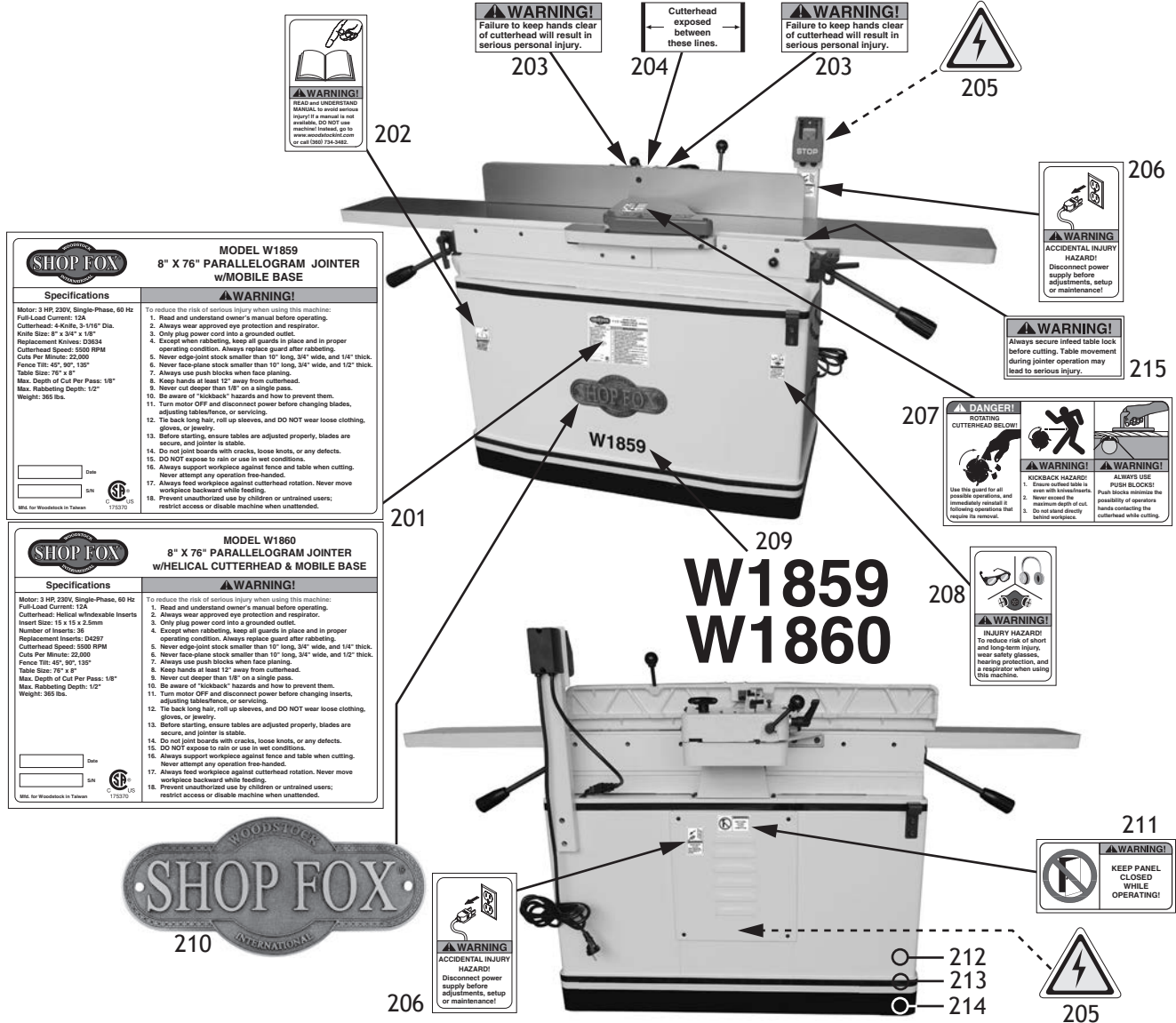

REF	PART #	DESCRIPTION
201	X1859201	MACHINE ID LABEL (W1859)
201	X1860201	MACHINE ID LABEL (W1860)
202	X1859202	READ MANUAL LABEL
203	X1859203	CUTTERHEAD WARNING LABEL
204	X1859204	CUTTERHEAD EXPOSED LABEL
205	X1859205	ELECTRICITY LABEL
206	X1859206	DISCONNECT POWER LABEL
207	X1859207	CUTTERHEAD GUARD LABEL
208	X1859208	EYES EARS LUNGS WARNING LABEL

REF	PART #	DESCRIPTION
209	X1859209	MODEL NUMBER LABEL (W1859)
209	X1860209	MODEL NUMBER LABEL (W1860)
210	X1859210	SHOP FOX NAMEPLATE-LARGE
211	X1859211	PANEL CLOSED WARNING LABEL
212	X1859212	TOUCH-UP PAINT, SHOP FOX WHITE
213	X1859213	BLACK TRIM TAPE
214	X1859214	TOUCH-UP PAINT, SHOP FOX BLACK
215	X1859215	INFED TABLE LOCK WARNING LABEL

⚠ WARNING

Safety labels warn about machine hazards and how to prevent serious personal injury. The owner of this machine **MUST** maintain the original location and readability of all labels on this machine. If any label is removed or becomes unreadable, **REPLACE** that label before allowing machine to be operated again. Contact us at (360) 734-3482 or www.woodstockint.com to order new labels.

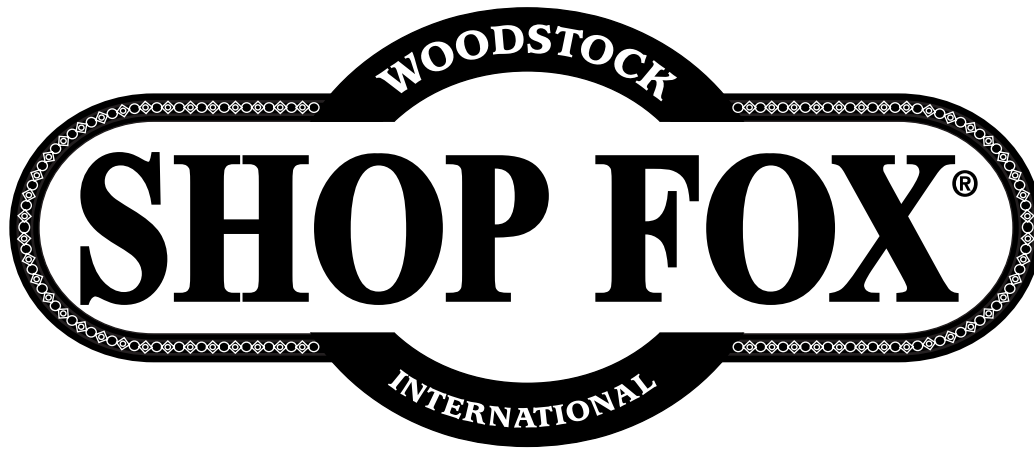

**MODEL W1859/W1860
8" X 76" PARALLELOGRAM
JOINTER W/MOBILE BASE**



OWNER'S MANUAL
(FOR MODELS MANUFACTURED SINCE 02/20)



Phone: (360) 734-3482 • Online Technical Support: techsupport@woodstockint.com

COPYRIGHT © NOVEMBER, 2018 BY WOODSTOCK INTERNATIONAL, INC. REVISED JUNE, 2020 (MN)

WARNING: NO PORTION OF THIS MANUAL MAY BE REPRODUCED IN ANY SHAPE OR FORM WITHOUT

THE WRITTEN APPROVAL OF WOODSTOCK INTERNATIONAL, INC.

V4.06.20

#19884ES Printed in Taiwan



WARNING!

This manual provides critical safety instructions on the proper setup, operation, maintenance, and service of this machine/tool. Save this document, refer to it often, and use it to instruct other operators.

Failure to read, understand and follow the instructions in this manual may result in fire or serious personal injury—including amputation, electrocution, or death.

The owner of this machine/tool is solely responsible for its safe use. This responsibility includes but is not limited to proper installation in a safe environment, personnel training and usage authorization, proper inspection and maintenance, manual availability and comprehension, application of safety devices, cutting/sanding/grinding tool integrity, and the usage of personal protective equipment.

The manufacturer will not be held liable for injury or property damage from negligence, improper training, machine modifications or misuse.



WARNING!

Some dust created by power sanding, sawing, grinding, drilling, and other construction activities contains chemicals known to the State of California to cause cancer, birth defects or other reproductive harm. Some examples of these chemicals are:

- Lead from lead-based paints.
- Crystalline silica from bricks, cement and other masonry products.
- Arsenic and chromium from chemically-treated lumber.

Your risk from these exposures varies, depending on how often you do this type of work. To reduce your exposure to these chemicals: Work in a well ventilated area, and work with approved safety equipment, such as those dust masks that are specially designed to filter out microscopic particles.

Contents

INTRODUCTION	2	ACCESSORIES	35
Machine Differences	2	Jointer Accessories.....	35
Woodstock Technical Support	2	MAINTENANCE	37
Machine Specifications (W1859)	3	General	37
Machine Specifications (W1860)	5	Cleaning & Protecting	37
Identification	7	Lubrication	38
Controls & Components	8	SERVICE	39
SAFETY	10	General	39
Standard Machinery Safety Instructions	10	Setting/Replacing Knives (W1859).....	39
Additional Safety for Jointers.....	12	Rotating/Replacing Helical Cutterhead	
ELECTRICAL	13	Inserts (W1860).....	43
Circuit Requirements	13	Checking/Adjusting Table Parallelism	45
Grounding Requirements.....	14	Setting Outfeed Table Height	49
Extension Cords	14	Calibrating 1/8" Infeed Table Stop	50
SETUP	15	Setting Fence Stops.....	51
Unpacking	15	Calibrating Depth-of-Cut Scale	54
Items Needed for Setup.....	15	Tensioning/Replacing Belt	55
Inventory	16	Checking/Aligning Pulleys	56
Cleaning Machine.....	17	Checking/Adjusting Cutterhead Guard	57
Machine Placement	18	Troubleshooting.....	58
Assembly.....	19	Electrical Safety Instructions.....	60
Knife-Setting Jig (W1859).....	21	Wiring Diagram	61
Dust Collection	22	PARTS	62
Test Run.....	23	Tables, Fence & Cutterhead.....	62
Tensioning Belt	23	Base, Stand & Motor	63
Disabling & Locking Switch	24	Labels & Cosmetics	66
OPERATIONS	25	WARRANTY	69
General	25		
Stock Inspection.....	26		
Squaring Stock	27		
Surface Planing	28		
Edge Jointing	29		
Bevel Cutting	30		
Rabbet Cutting	31		
Setting Depth of Cut.....	33		





INTRODUCTION

Machine Differences

Models W1859 and W1860 are 3 HP, 8" x 76" jointers with the following differences:

- **Model W1859** has a 4-knife cutterhead with high-speed steel knives.
- **Model W1860** has a helical cutterhead with 4 helicals and 36 indexable carbide inserts.

Woodstock Technical Support

This machine has been specially designed to provide many years of trouble-free service. Close attention to detail, ruggedly built parts and a rigid quality control program assure safe and reliable operation.

Woodstock International, Inc. is committed to customer satisfaction. Our intent with this manual is to include the basic information for safety, setup, operation, maintenance, and service of this product.

We stand behind our machines! In the event that questions arise about your machine, please contact Woodstock International Technical Support at (360) 734-3482 or send e-mail to: tech-support@shopfox.biz. Our knowledgeable staff will help you troubleshoot problems and process warranty claims.

If you need the latest edition of this manual, you can download it from <http://www.shopfox.biz>.
If you have comments about this manual, please contact us at:

Woodstock International, Inc.
Attn: Technical Documentation Manager
P.O. Box 2309
Bellingham, WA 98227
Email: manuals@woodstockint.com



MACHINE SPECIFICATIONS



© Woodstock International, Inc. • Phone: (800) 840-8420 • Web: www.shopfox.biz

MODEL W1859 8" X 76" PARALLELOGRAM JOINTER WITH MOBILE BASE

Product Dimensions

Weight..... 365 lbs.
 Width (side-to-side) x Depth (front-to-back) x Height..... 76 x 25 x 41-1/2 in.
 Footprint (Length x Width)..... 40 x 16 in.

Shipping Dimensions

Type..... Wood Crate
 Content..... Machine
 Weight..... 470 lbs.
 Length x Width x Height..... 85 x 26 x 43 in.
 Must Ship Upright..... Yes

Electrical

Power Requirement..... 230V, Single-Phase, 60 Hz
 Motor Size..... 3 HP
 Full-Load Current Rating..... 12A
 Minimum Circuit Size..... 20A
 Connection Type..... Cord & Plug
 Power Cord Included..... Yes
 Power Cord Length..... 6 ft.
 Power Cord Gauge..... 14 AWG
 Plug Included..... Yes
 Included Plug Type..... 6-20
 Switch Type..... Push Button Magnetic w/Large Shut-Off Paddle

Motors

Main

Horsepower..... 3 HP
 Phase..... Single-Phase
 Amps..... 12A
 Speed..... 3450 RPM
 Type..... TEFC Capacitor-Start Induction
 Power Transfer Belt Drive
 Bearings..... Sealed & Permanently Lubricated
 Centrifugal Switch/Contacts Type..... External



Main Specifications

Main Specifications

Jointer Size.....	8 in.
Bevel Jointing.....	0 - 45 deg. L/R
Maximum Width of Cut.....	8 in.
Maximum Depth of Cut.....	1/8 in.
Minimum Workpiece Length.....	10 in.
Minimum Workpiece Thickness.....	1/2 in.
Maximum Rabbeting Depth.....	1/2 in.
Number of Cuts Per Minute.....	22,000

Fence Information

Fence Length.....	38 in.
Fence Width.....	1-1/4 in.
Fence Height.....	4-1/2 in.
Fence Stops.....	45, 90, 135 deg.

Cutterhead Information

Cutterhead Type.....	4 Knife
Cutterhead Diameter.....	3-1/16 in.
Cutterhead Speed.....	5500 RPM

Knife Information

Number of Knives.....	4
Knife Type.....	HSS, Single-Sided
Knife Length.....	8 in.
Knife Width.....	3/4 in.
Knife Thickness.....	1/8 in.
Knife Adjustment.....	Jack Screws or Springs

Table Information

Table Length.....	76 in.
Table Width.....	8 in.
Table Thickness.....	1-3/4 in.
Floor to Table Height.....	31-1/4 in.
Table Adjustment Type.....	Lever Action
Table Movement Type.....	Parallelogram

Construction

Body Assembly.....	Cast Iron
Cabinet.....	Sheet Metal
Fence Assembly.....	Precision-Ground Cast Iron
Guard.....	Die-Cast Aluminum
Table.....	Precision-Ground Cast Iron
Paint Type/Finish.....	Powder Coated

Other Information

Number of Dust Ports.....	1
Dust Port Size.....	4 in.
Mobile Base.....	Built-In



MACHINE SPECIFICATIONS



© Woodstock International, Inc. • Phone: (800) 840-8420 • Web: www.shopfox.biz

MODEL W1860 8" X 76" PARALLELOGRAM JOINTER WITH HELICAL CUTTERHEAD & MOBILE BASE

Product Dimensions

Weight..... 365 lbs.
 Width (side-to-side) x Depth (front-to-back) x Height..... 76 x 25 x 41-1/2 in.
 Footprint (Length x Width)..... 40 x 16 in.

Shipping Dimensions

Type..... Wood Crate
 Content..... Machine
 Weight..... 470 lbs.
 Length x Width x Height..... 85 x 26 x 43 in.
 Must Ship Upright..... Yes

Electrical

Power Requirement..... 230V, Single-Phase, 60 Hz
 Motor Size..... 3 HP
 Full-Load Current Rating..... 12A
 Minimum Circuit Size..... 20A
 Connection Type..... Cord & Plug
 Power Cord Included..... Yes
 Power Cord Length..... 6 ft.
 Power Cord Gauge..... 14 AWG
 Plug Included..... Yes
 Included Plug Type..... 6-20
 Switch Type..... Push Button Magnetic w/Large Shut-Off Paddle

Motors

Main

Horsepower..... 3 HP
 Phase..... Single-Phase
 Amps..... 12A
 Speed..... 3450 RPM
 Type..... TEFC Capacitor-Start Induction
 Power Transfer Belt Drive
 Bearings..... Sealed & Permanently Lubricated
 Centrifugal Switch/Contacts Type..... External



Main Specifications

Main Specifications

Jointer Size.....	8 in.
Bevel Jointing.....	0 - 45 deg. L/R
Maximum Width of Cut.....	8 in.
Maximum Depth of Cut.....	1/8 in.
Minimum Workpiece Length.....	10 in.
Minimum Workpiece Thickness.....	1/2 in.
Maximum Rabbeting Depth.....	1/2 in.
Number of Cuts Per Minute.....	22,000

Fence Information

Fence Length.....	38 in.
Fence Width.....	1-1/4 in.
Fence Height.....	4-1/2 in.
Fence Stops.....	45, 90, 135 deg.

Cutterhead Information

Cutterhead Type.....	Helical
Cutterhead Diameter.....	3-1/16 in.
Number of Cutter Rows.....	4
Number of Indexable Cutters.....	36
Cutterhead Speed.....	5500 RPM

Cutter Insert Information

Cutter Insert Type.....	Indexable Carbide
Cutter Insert Length.....	15 mm
Cutter Insert Width.....	15 mm
Cutter Insert Thickness.....	2.5 mm

Table Information

Table Length.....	76 in.
Table Width.....	8 in.
Table Thickness.....	1-3/4 in.
Floor to Table Height.....	31-1/4 in.
Table Adjustment Type.....	Lever Action
Table Movement Type.....	Parallelogram

Construction

Body Assembly.....	Cast Iron
Cabinet.....	Sheet Metal
Fence Assembly.....	Precision-Ground Cast Iron
Guard.....	Die-Cast Aluminum
Table.....	Precision-Ground Cast Iron
Paint Type/Finish.....	Powder Coated

Other Information

Number of Dust Ports.....	1
Dust Port Size.....	4 in.
Mobile Base.....	Built-In

Identification

Become familiar with the names and locations of the controls and features shown below to better understand the instructions in this manual.

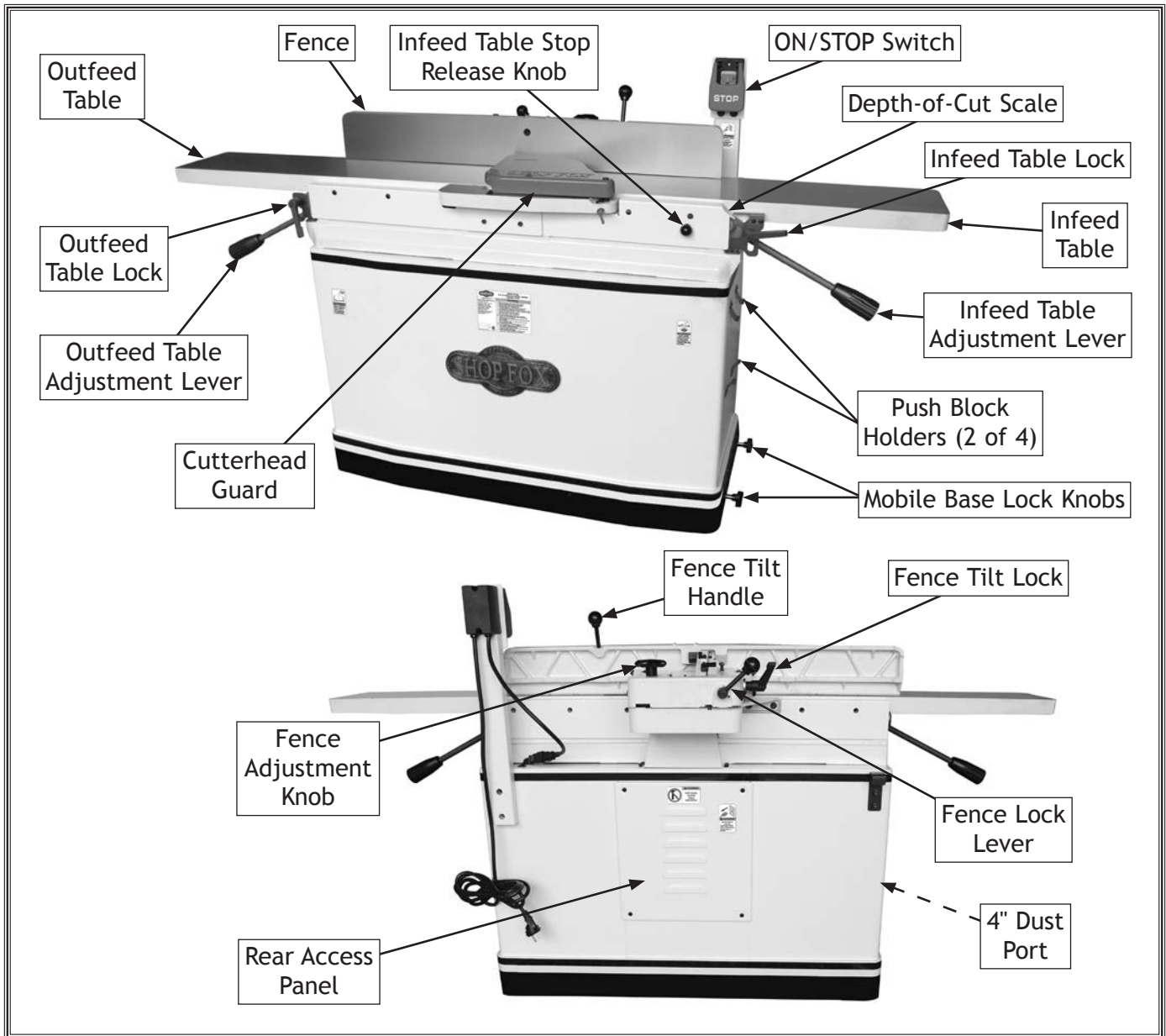

WARNING

For Your Own Safety Read Instruction Manual Before Operating Jointer

- a) Wear eye protection.
- b) Always keep cutterhead and drive guards in place and in proper operating condition. If removed, ALWAYS replace cutterhead guard immediately after rabbeting operations.
- c) Never make cuts deeper than $\frac{1}{8}$ " per pass.
- d) Always use hold-down or push blocks when jointing material narrower than 3" or planing material thinner than 3".
- e) Never perform jointing, planing, or rabbeting cuts on pieces shorter than 10" in length.

Controls & Components

Refer to the **Figures 1-4** and the following descriptions to become familiar with the basic controls and components of this machine. Understanding these items and how they work will help you understand the rest of the manual and stay safe when operating this machine.

- A. **ON Button:** Push to start motor. Insert padlock through button to disable (padlock not included).
- B. **STOP Paddle:** Push to stop motor.
- C. **Outfeed Table:** Supports workpiece after it passes over cutterhead. For optimum results, outfeed table must be properly adjusted even with highest point of cutterhead knives/inserts.
- D. **Fence:** Supports workpiece laterally as it moves across cutterhead; determines angle of cut when edge or bevel jointing.
- E. **Infeed Table:** Supports workpiece before it reaches cutterhead. Position of infeed table relative to cutterhead knives/inserts determines depth of cut.
- F. **Infeed Table Adjustment Lever:** Move up or down to adjust position of infeed table (when infeed table lock is loosened).
- G. **Mobile Base Lock Knobs:** Tighten to secure jointer in position; loosen to move jointer.
- H. **Outfeed Table Adjustment Lever:** Move up or down to adjust position of outfeed table (when outfeed table lock is loosened). Only used when setting outfeed table even with cutterhead knives/inserts.

WARNING



To reduce your risk of serious injury or damage to the machine, read this entire manual **BEFORE** using machine.

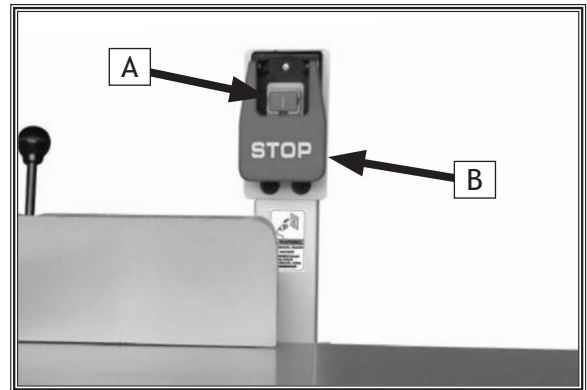

Figure 1. ON/STOP controls.

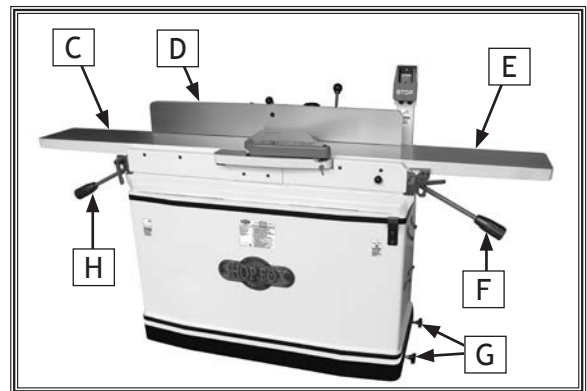

Figure 2. Table controls and components, fence, and mobile base lock knobs.

- I. **Cutterhead Guard:** Covers cutterhead until workpiece pushes guard out of the way during operation. When workpiece leaves cutterhead, guard springs back to its starting position.
 - J. **Depth-of-Cut Scale:** Shows depth of cut (per pass).
 - K. **Infeed Table Lock:** Tighten to secure infeed table position; loosen for table adjustment.
 - L. **Table Release Knob:** Pull out to lower infeed table more than $\frac{1}{8}$ ". Infeed table is factory-set to automatically stop at $\frac{1}{8}$ ".
 - M. **Outfeed Table Lock:** Tighten to secure outfeed table position; loosen for table adjustment.
 - N. **Fence Tilt Handle:** Use to tilt fence throughout its range of motion from 45° inward to 45° outward (135°). (Fence tilt lock must be loosened first.)
 - O. **90° Stop Block:** Swivels to engage with 90° stop bolt. When engaged, stops fence at 90°. When disengaged, allows bevel cuts greater than 90°.
 - P. **45° Inward Fence Stop:** Stops fence at 45° inward.
 - Q. **90° Fence Stop:** Stops fence at 90°.
 - R. **45° Outward Fence Stop:** Stops fence at 45° outward (135°).
 - S. **Fence Tilt Lock:** Secures fence at any position in available tilt range.
- IMPORTANT:** Always tighten tilt lock before starting machine—even when fence is resting against stops.
- T. **Fence Lock Lever:** Secures fence position.
 - U. **Fence Adjustment Knob:** Moves fence position forward/backward. (Fence lock lever must be loosened first.)

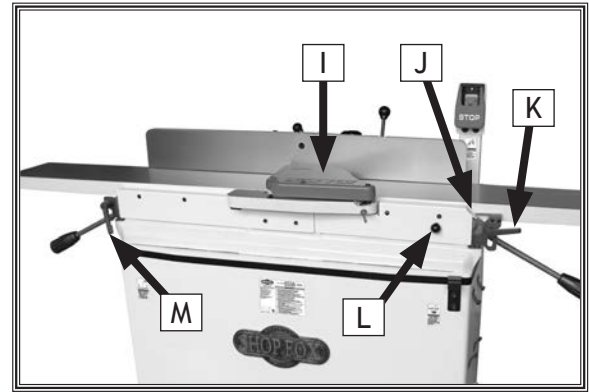

Figure 3. Table locks, cutterhead guard, and depth-of-cut scale.

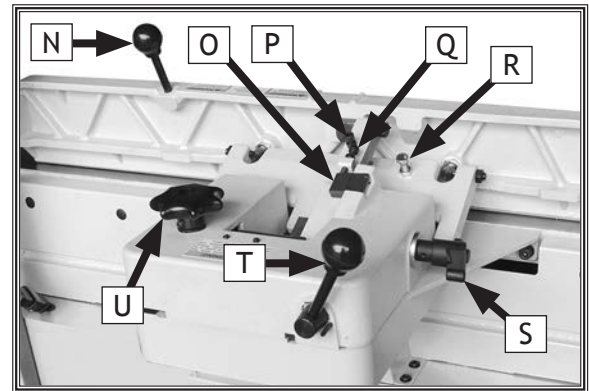

Figure 4. Fence controls and components.

SAFETY

For Your Own Safety, Read Manual Before Operating Machine

The purpose of safety symbols is to attract your attention to possible hazardous conditions. This manual uses a series of symbols and signal words intended to convey the level of importance of the safety messages. The progression of symbols is described below. Remember that safety messages by themselves do not eliminate danger and are not a substitute for proper accident prevention measures—this responsibility is ultimately up to the operator!



Indicates an imminently hazardous situation which, if not avoided, **WILL** result in death or serious injury.



Indicates a potentially hazardous situation which, if not avoided, **COULD** result in death or serious injury.



Indicates a potentially hazardous situation which, if not avoided, **MAY** result in minor or moderate injury.

NOTICE

This symbol is used to alert the user to useful information about proper operation of the equipment or a situation that may cause damage to the machinery.

Standard Machinery Safety Instructions

OWNER'S MANUAL. Read and understand this owner's manual **BEFORE** using machine.

TRAINED OPERATORS ONLY. Untrained operators have a higher risk of being hurt or killed. Only allow trained/supervised people to use this machine. When machine is not being used, disconnect power, remove switch keys, or lock-out machine to prevent unauthorized use—especially around children. Make workshop kid proof!

DANGEROUS ENVIRONMENTS. Do not use machinery in areas that are wet, cluttered, or have poor lighting. Operating machinery in these areas greatly increases the risk of accidents and injury.

MENTAL ALERTNESS REQUIRED. Full mental alertness is required for safe operation of machinery. Never operate under the influence of drugs or alcohol, when tired, or when distracted.

ELECTRICAL EQUIPMENT INJURY RISKS. You can be shocked, burned, or killed by touching live electrical components or improperly grounded machinery. To reduce this risk, only allow an electrician or qualified service personnel to do electrical installation or repair work, and always disconnect power before accessing or exposing electrical equipment.

DISCONNECT POWER FIRST. Always disconnect machine from power supply **BEFORE** making adjustments, changing tooling, or servicing machine. This eliminates the risk of injury from unintended startup or contact with live electrical components.

EYE PROTECTION. Always wear ANSI-approved safety glasses or a face shield when operating or observing machinery to reduce the risk of eye injury or blindness from flying particles. Everyday eyeglasses are not approved safety glasses.

WEARING PROPER APPAREL. Do not wear clothing, apparel, or jewelry that can become entangled in moving parts. Always tie back or cover long hair. Wear non-slip footwear to avoid accidental slips, which could cause loss of workpiece control.

HAZARDOUS DUST. Dust created while using machinery may cause cancer, birth defects, or long-term respiratory damage. Be aware of dust hazards associated with each workpiece material, and always wear a NIOSH-approved respirator to reduce your risk.

HEARING PROTECTION. Always wear hearing protection when operating or observing loud machinery. Extended exposure to this noise without hearing protection can cause permanent hearing loss.

REMOVE ADJUSTING TOOLS. Tools left on machinery can become dangerous projectiles upon startup. Never leave chuck keys, wrenches, or any other tools on machine. Always verify removal before starting!

INTENDED USAGE. Only use machine for its intended purpose—never make modifications without prior approval from Woodstock International. Modifying machine or using it differently than intended will void the warranty and may result in malfunction or mechanical failure that leads to serious personal injury or death!

AWKWARD POSITIONS. Keep proper footing and balance at all times when operating machine. Do not overreach! Avoid awkward hand positions that make workpiece control difficult or increase the risk of accidental injury.

CHILDREN & BYSTANDERS. Keep children and bystanders at a safe distance from the work area. Stop using machine if they become a distraction.

GUARDS & COVERS. Guards and covers reduce accidental contact with moving parts or flying debris—make sure they are properly installed, undamaged, and working correctly.

FORCING MACHINERY. Do not force machine. It will do the job safer and better at the rate for which it was designed.

NEVER STAND ON MACHINE. Serious injury may occur if machine is tipped or if the cutting tool is unintentionally contacted.

STABLE MACHINE. Unexpected movement during operation greatly increases risk of injury or loss of control. Before starting, verify machine is stable and mobile base (if used) is locked.

USE RECOMMENDED ACCESSORIES. Consult this owner's manual or the manufacturer for recommended accessories. Using improper accessories will increase risk of serious injury.

UNATTENDED OPERATION. To reduce the risk of accidental injury, turn machine **OFF** and ensure all moving parts completely stop before walking away. Never leave machine running while unattended.

MAINTAIN WITH CARE. Follow all maintenance instructions and lubrication schedules to keep machine in good working condition. A machine that is improperly maintained could malfunction, leading to serious personal injury or death.

CHECK DAMAGED PARTS. Regularly inspect machine for any condition that may affect safe operation. Immediately repair or replace damaged or mis-adjusted parts before operating machine.

MAINTAIN POWER CORDS. When disconnecting cord-connected machines from power, grab and pull the plug—NOT the cord. Pulling the cord may damage the wires inside, resulting in a short. Do not handle cord/plug with wet hands. Avoid cord damage by keeping it away from heated surfaces, high traffic areas, harsh chemicals, and wet/damp locations.

EXPERIENCING DIFFICULTIES. If at any time you experience difficulties performing the intended operation, stop using the machine! Contact Technical Support at (360) 734-3482.

Additional Safety for Jointers

Serious cuts, amputation, entanglement, or death can occur from contact with rotating cutterhead or other moving components! Flying chips from cutting operations can cause eye injuries or blindness. Workpieces or inserts/knives thrown by cutterhead (kickback) can strike nearby operator or bystanders with deadly force. To reduce the risk of serious personal injury from these hazards, operator and bystanders **MUST** completely heed the hazards and warnings below.

KICKBACK. Occurs when workpiece is ejected from machine at high rate of speed. Kickback injuries occur from getting struck by workpiece or hands being pulled into cutterhead. To reduce risk of kickback, only use proper workpieces, safe feeding techniques, and proper machine setup.

GUARD REMOVAL. Operating jointer without guards exposes operator to knives/inserts and other hazardous moving parts. Except when rabbeting, never operate jointer or allow it to be connected to power if any guards are removed. Turn jointer **OFF** and disconnect power before clearing any shavings or sawdust from around cutterhead. After rabbeting or maintenance is complete, immediately replace all guards and ensure they are properly installed/adjusted before resuming regular operations.

DULL/DAMAGED KNIVES/INSERTS. Dull or damaged knives/inserts increase risk of kickback and cause poor workpiece finish. Only use sharp, undamaged knives/inserts.

OUTFEED TABLE ALIGNMENT. Setting outfeed table too high can cause workpiece to hit table or get stuck while feeding. Setting outfeed table too low may cause workpiece to rock or shift while feeding. Both results will increase risk of kickback. Always keep outfeed table even with knives/inserts at highest point during rotation.

INSPECTING STOCK. Impact injuries or kickback may result from using improper workpieces. Thoroughly inspect and prepare workpiece before cutting. Verify workpiece is free of nails, staples, loose knots or other foreign material.

MAXIMUM CUTTING DEPTH. To reduce risk of kickback, never cut deeper than 1/8".

GRAIN DIRECTION. Jointing against the grain or end grain can increase the risk of kickback. It also requires more cutting force, which produces chatter or excessive chip out. Always joint or surface plane with the grain.

CUTTING LIMITATIONS. Cutting workpieces that do not meet minimum dimension requirements can result in kickback or accidental contact with cutterhead. Never perform jointing, planing, or rabbeting cuts on pieces smaller than specified in data sheet.

PUSH BLOCKS. Push blocks reduce risk of accidental cutterhead contact with hands. Always use push blocks when planing materials less than 3" high or wide. Never pass your hands directly over cutterhead without a push block.

WORKPIECE SUPPORT. Poor workpiece support or loss of workpiece control while feeding will increase risk of kickback or accidental contact with cutterhead. Support workpiece with fence continuously during operation. Support long stock with auxiliary table if necessary.

FEED WORKPIECE PROPERLY. Kickback or accidental cutterhead contact may result if workpiece is fed into cutterhead the wrong way. Allow cutterhead to reach full speed before feeding. Never start jointer with workpiece touching cutterhead. Always feed workpiece from infeed side to outfeed side without stopping until cut is complete. Never move workpiece backwards while feeding.

SECURE KNIVES/INSERTS. Loose knives or improperly set inserts can be thrown from cutterhead with dangerous force. Always verify knives/inserts are secure and properly adjusted before operation. Straight knives should never project more than 1/8" (0.125") from cutterhead body.

ELECTRICAL

Circuit Requirements

This machine must be connected to the correct size and type of power supply circuit, or fire or electrical damage may occur. Read through this section to determine if an adequate power supply circuit is available. If a correct circuit is not available, a qualified electrician **MUST** install one before you can connect the machine to power.

A power supply circuit includes all electrical equipment between the breaker box or fuse panel in the building and the machine. The power supply circuit used for this machine must be sized to safely handle the full-load current drawn from the machine for an extended period of time. (If this machine is connected to a circuit protected by fuses, use a time delay fuse marked D.)

Full-Load Current Rating

The full-load current rating is the amperage a machine draws at 100% of the rated output power. On machines with multiple motors, this is the amperage drawn by the largest motor or sum of all motors and electrical devices that might operate at one time during normal operations.

Full-Load Current Rating at 230V 12 Amps

Circuit Requirements

This machine is prewired to operate on a power supply circuit that has a verified ground and meets the following requirements:

Circuit Type 220V/240V, 60 Hz, Single-Phase
Circuit Size 20 Amps
Plug/Receptacle NEMA 6-20

⚠ WARNING

The machine must be properly set up before it is safe to operate. **DO NOT** connect this machine to the power source until instructed to do so later in this manual.

⚠ WARNING



Incorrectly wiring or grounding this machine can cause electrocution, fire, or machine damage. To reduce this risk, only an electrician or qualified service personnel should do any required electrical work on this machine.

NOTICE

The circuit requirements listed in this manual apply to a dedicated circuit—where only one machine will be running at a time. If this machine will be connected to a shared circuit where multiple machines will be running at the same time, consult with an electrician to ensure that the circuit is properly sized for safe operation.

ELECTRICAL

Grounding Requirements

This machine **MUST** be grounded. In the event of certain types of malfunctions or breakdowns, grounding provides a path of least resistance for electric current to travel—in order to reduce the risk of electric shock.

Improper connection of the equipment-grounding wire will increase the risk of electric shock. The wire with green insulation (with/without yellow stripes) is the equipment-grounding wire. If repair or replacement of the power cord or plug is necessary, do not connect the equipment-grounding wire to a live (current carrying) terminal.

Check with a qualified electrician or service personnel if you do not understand these grounding requirements, or if you are in doubt about whether the tool is properly grounded. If you ever notice that a cord or plug is damaged or worn, disconnect it from power, and immediately replace it with a new one.

For 220V Connection

This machine is equipped with a power cord that has an equipment-grounding wire and NEMA 6-15 grounding plug (see figure). The plug must only be inserted into a matching receptacle that is properly installed and grounded in accordance with local codes and ordinances.

Extension Cords

We do not recommend using an extension cord with this machine. Extension cords cause voltage drop, which may damage electrical components and shorten motor life. Voltage drop increases with longer extension cords and smaller gauge sizes (higher gauge numbers indicate smaller sizes).

Any extension cord used with this machine must contain a ground wire, match the required plug and receptacle, and meet the following requirements:

- Minimum Gauge Size at 220V 12 AWG
- Maximum Length (Shorter is Better) 50 ft.

ELECTRICAL

⚠ WARNING

The machine must be properly set up before it is safe to operate. **DO NOT** connect this machine to the power source until instructed to do so later in this manual.

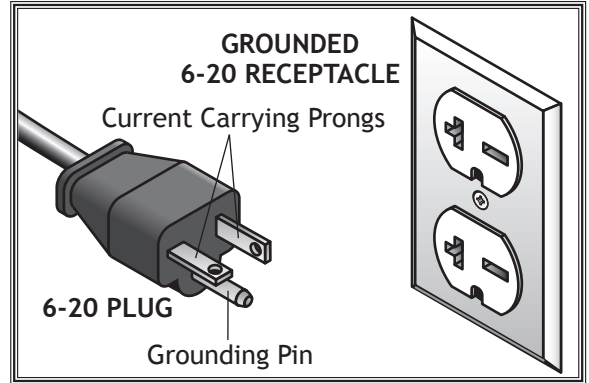

Figure 5. NEMA 6-20 plug & receptacle.

⚠ CAUTION

No adapter should be used with the required plug. If the plug does not fit the available receptacle or the machine must be reconnected to a different type of circuit, the reconnection must be made by an electrician or qualified service personnel and it must comply with all local codes and ordinances.

SETUP

Unpacking

This machine has been carefully packaged for safe transportation. If you notice the machine has been damaged during shipping, please contact your authorized Shop Fox dealer immediately.

Items Needed for Setup

The following items are needed, but not included, to set up your machine.

Description	Qty
• Additional People.....	1-3
• Safety Glasses.....	1 ea.
• Leather Gloves.....	1 Pair ea.
• Cleaner/Degreaser	As Needed
• Disposable Rags	As Needed
• Lifting Equipment (Min. 1000-lb Rating):	
—Forklift or Hoist	1
—Lifting Slings.....	2
• Precision Straightedge 3'	1
• Phillips Screwdriver #2	1
• Dust-Collection System	1
• 4" Dust Hose (length as needed).....	1
• 4" Hose Clamp.....	1



!WARNING

This machine presents serious injury hazards to untrained users. Read through this entire manual to become familiar with the controls and operations before starting the machine!



!WARNING

Wear safety glasses during entire setup process!



!WARNING

HEAVY LIFT!

Straining or crushing injury may occur from improperly lifting the machine or some of its parts. To reduce this risk, get help from other people and use a forklift (or other lifting equipment) rated for weight of machine.

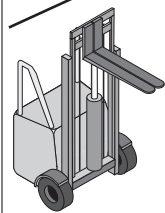

SETUP

Inventory

The following is a list of items shipped with your machine. Before beginning setup, lay these items out and inventory them.

Note: If you cannot find an item on this list, carefully check around/inside the machine and packaging materials. Often, these items get lost in packaging materials while unpacking or they are pre-installed at the factory.

Inventory (Figures 6-7):	Qty
A. Jointer Assembly.....	1
B. Lifting Hooks	2
C. Lock Washers 8mm (Lifting Hooks)	4
D. Cap Screws M8-1.25 x 20 (Lifting Hooks)	4
E. Fence Tilt Handle.....	1
F. Push Blocks	2
G. Open-End Wrench 11/13mm	1
H. Open-End Wrench 8/10mm	1
I. Hex Wrench 6mm.....	1
J. Knife-Setting Jig (W1859)	
—E-Clips	4
—Knife Jig Feet	2
—Knife Jig Rod.....	1
K. Helical Cutterhead Accessories (W1860)	
—T-Handle Torx Driver T-25	2
—Torx Screws T-25 #10-32 x 1/2.....	10
—Indexable Inserts 15 x 15 x 2.5mm	5
L. Knob Bolts M10-1.5 x 22.....	2
M. Hex Wrench 4mm.....	1
N. Cutterhead Guard Assembly	1

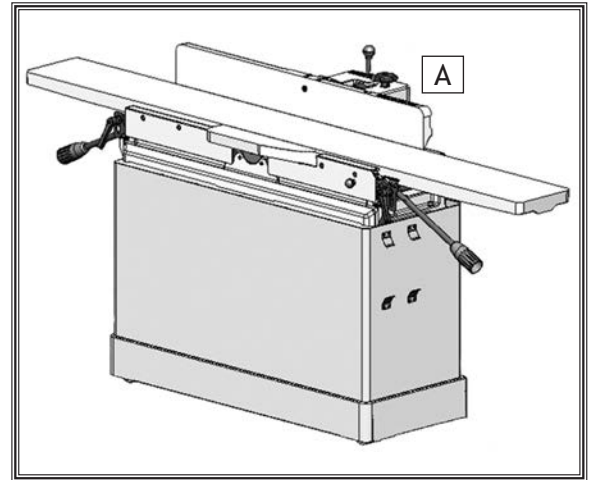

Figure 6. Inventory—jointer assembly.

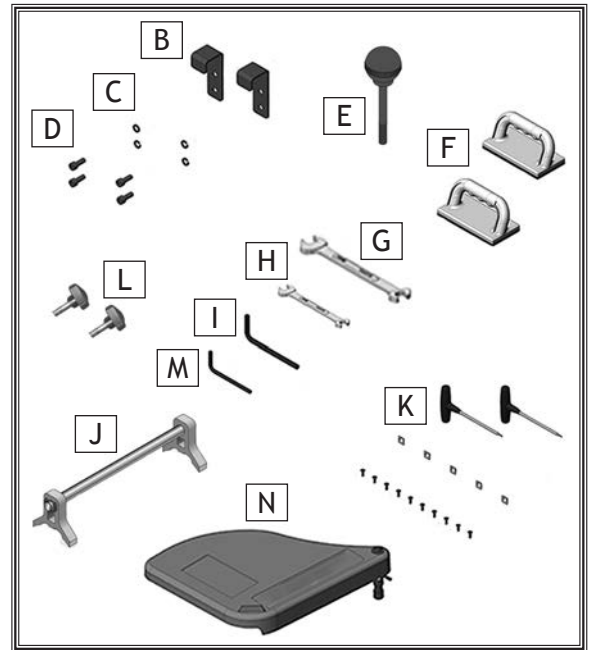

Figure 7. Inventory—loose items.

Cleaning Machine

To prevent corrosion during shipment and storage of your machine, the factory has coated the bare metal surfaces of your machine with a heavy-duty rust prevention compound.

If you are unprepared or impatient, this compound can be difficult to remove. To ensure that the removal of this coating is as easy as possible, please gather the correct cleaner, lubricant, and tools listed below:

- Cleaner/degreaser designed to remove storage wax and grease
- Safety glasses & disposable gloves
- Solvent brush or paint brush
- Disposable Rags

To remove rust preventative coating, do these steps:

1. DISCONNECT MACHINE FROM POWER!
2. Put on safety glasses and disposable gloves.
3. Coat the rust preventative with a liberal amount of cleaner/degreaser, then let it soak for 5-10 minutes.
4. Wipe off surfaces. If your cleaner/degreaser is effective, the coating will wipe off easily.

Tip: *An easier way to clean off thick coats of rust preventative from flat surfaces is to use a PLASTIC paint scraper to scrape off the majority of the coating before wiping it off with your rag. (Do not use a metal scraper or you may scratch your machine.)*

5. Repeat cleaning steps as necessary until all of the compound is removed.
6. To prevent rust on freshly cleaned surfaces, immediately coat with a quality metal protectant.

WARNING

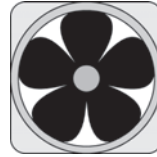

Gasoline and petroleum products have low flash points and can explode or cause fire if used to clean machinery. Avoid using these products to clean machinery. Many cleaning solvents are toxic if inhaled. Minimize your risk by only using these products in a well ventilated area.

NOTICE

In a pinch, automotive degreasers, mineral spirits or WD•40 can be used to remove rust preventative coating. Before using these products, though, test them on an inconspicuous area of your paint to make sure they will not damage it.

Machine Placement

Weight Load

Refer to the **Machine Specifications** for the weight of your machine. Make sure that the surface upon which the machine is placed will bear the weight of the machine, additional equipment that may be installed on the machine, and the heaviest workpiece that will be used. Additionally, consider the weight of the operator and any dynamic loading that may occur when operating the machine.

Space Allocation

Consider the largest size of workpiece that will be processed through this machine and provide enough space around the machine for adequate operator material handling or the installation of auxiliary equipment. With permanent installations, leave enough space around the machine to open or remove doors/covers as required by the maintenance and service described in this manual. See below for required space allocation.

Physical Environment

The physical environment where your machine is operated is important for safe operation and the longevity of its components. For best results, operate this machine in a dry environment that is free from excessive moisture, hazardous chemicals, airborne abrasives, or extreme conditions. Extreme conditions for this type of machinery are generally those where the ambient temperature range exceeds 41°-104°F; the relative humidity range exceeds 20-95% (non-condensing); or the environment is subject to vibration, shocks, or bumps.

Electrical Installation

Place this machine near an existing power source. Make sure all power cords are protected from traffic, material handling, moisture, chemicals, or other hazards. Make sure to leave access to a means of disconnecting the power source or engaging a lockout/tagout device.

Lighting

Lighting around the machine must be adequate enough that operations can be performed safely. Shadows, glare, or strobe effects that may distract or impede the operator must be eliminated.

SETUP

	<p>⚠ CAUTION</p> <p>Children or untrained people may be seriously injured by this machine. Only install in an access restricted location.</p>
--	--

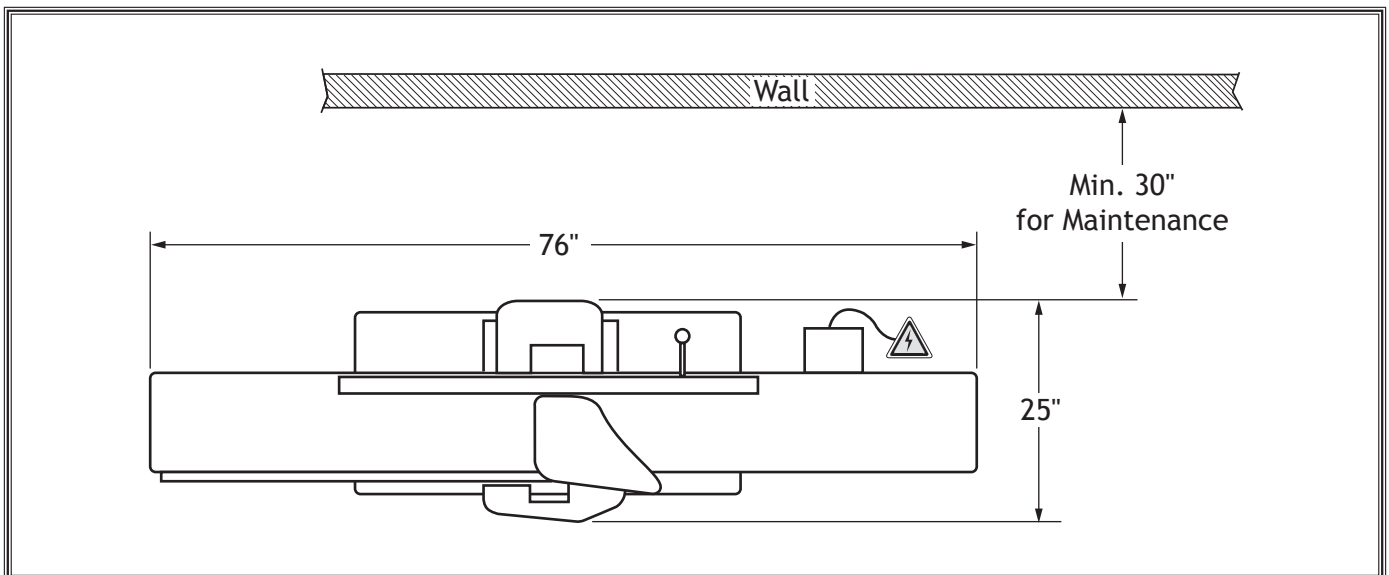

Figure 8. Working clearances.

Assembly

Before beginning the assembly process, refer to **Items Needed for Setup** and gather everything you need. Ensure all parts have been properly cleaned of any heavy-duty rust-preventative applied at the factory (if applicable). Be sure to complete all steps in the assembly procedure prior to performing the **Test Run** or connecting

This jointer is equipped with a mobile base to allow moving and placing of machine without power lifting equipment. **DO NOT** attempt to lift or move jointer without necessary assistance from other people. If using power lifting equipment (such as a forklift or crane), each piece of lifting equipment must be rated for at least 1000 lbs. to support dynamic loads that may be applied while lifting.

Review the **Electrical** section (see **Page 13**), then prepare a permanent location for the jointer.

To assemble machine, do these steps:

1. Remove top and sides of shipping crate, then place small items aside in safe location.

IMPORTANT: Do not destroy crate or packaging until after Test Run.
2. If moving and placing jointer without power lifting equipment, carefully "walk" machine off the shipping pallet with the help of other people and roll it to its prepared location. Proceed to **Step 4**.
3. If moving and placing machine with power lifting equipment, attach (2) lifting hooks to front and rear of jointer stand with (4) M8-1.25 x 20 cap screws and (4) 8mm lock washers (see **Figure 9**).

IMPORTANT: If using power lifting equipment, attach lifting slings to lifting hooks. **DO NOT** attach slings to jointer tables! After lifting, remove lifting hooks and roll jointer to its prepared location.



! WARNING

HEAVY LIFT!

Straining or crushing injury may occur from improperly lifting the machine or some of its parts. To reduce this risk, get help from other people and use a forklift (or other lifting equipment) rated for weight of machine.

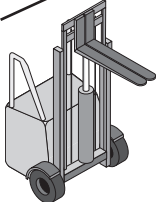

NOTICE

DO NOT lift this jointer by the tables. Doing so may affect factory-set table parallelism.

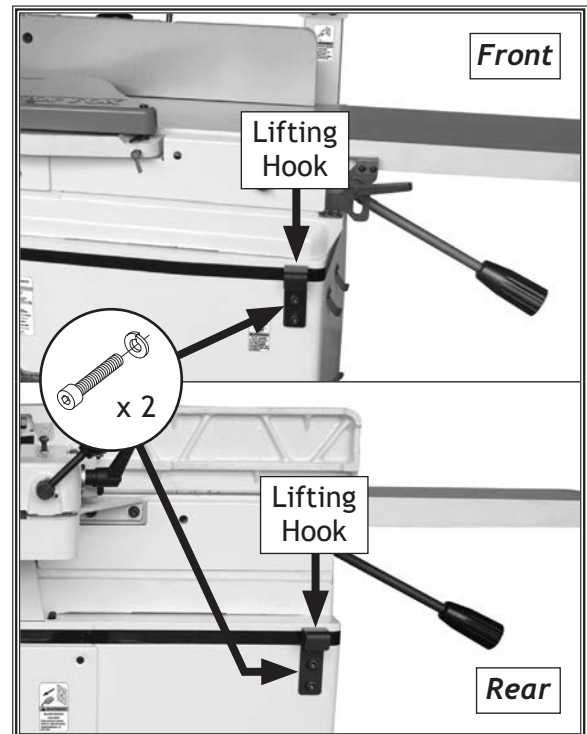

Figure 9. Lifting hooks attached.

SETUP

- Install (2) mobile base lock knobs (see **Figure 10**) so jointer will not easily move.

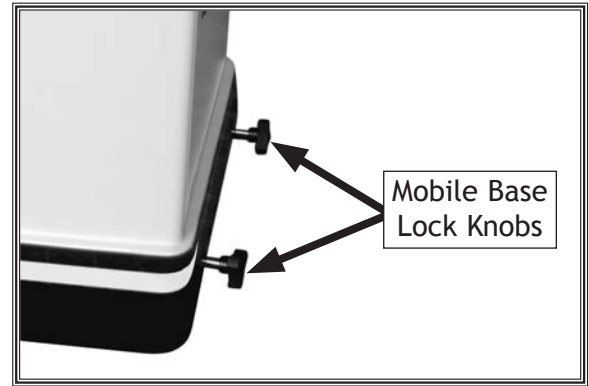

Figure 10. Mobile base lock knobs installed.

- Adjust feet (see **Figure 11**) as necessary until jointer is stable without any rocking or wobbling.

IMPORTANT: Ensure jointer is stable and unable to accidentally move prior to operations.

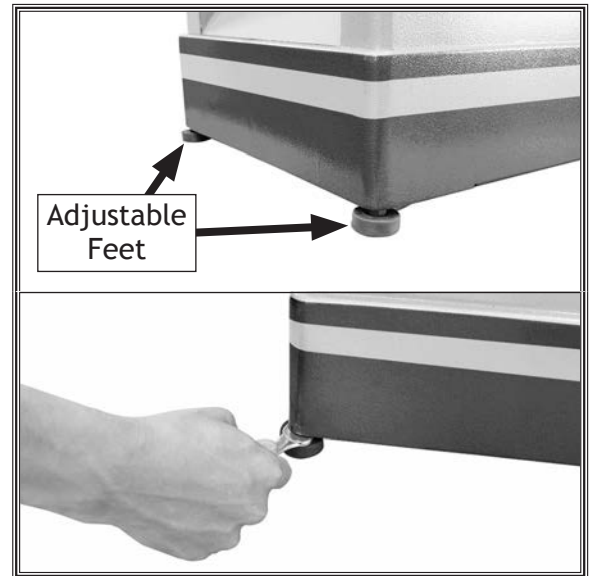

Figure 11. Leveling jointer.

- Reposition and secure switch pedestal (see **Figure 12**) in upright position with (2) pre-installed M8-1.25 x 20 cap screws and (2) 8mm lock washers.

Note: Switch pedestal is mounted upside-down for shipping purposes.

- Connect switch cord to motor cord and install fence tilt handle (see **Figure 12**).

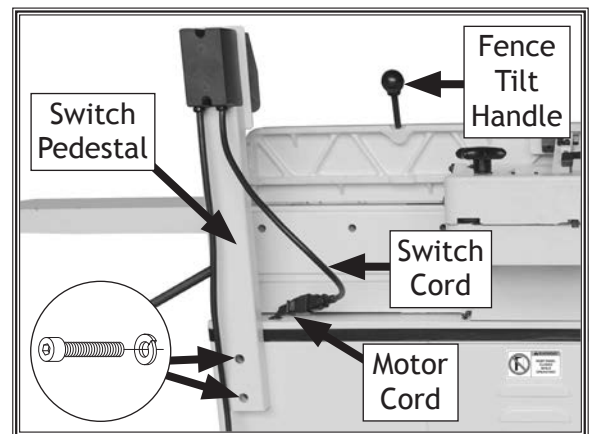

Figure 12. Switch pedestal attached to stand, cords connected, and fence tilt handle installed.

SETUP

8. Verify outfeed table height is set correctly with knives/inserts at top dead center (TDC) (refer to **Setting Outfeed Table Height** on Page 49) and all knives/inserts are securely tightened in cutterhead.
9. Set fence to 90° and move it all the way back.
10. Remove pre-installed button head cap screw and fender washer from bottom of cutterhead guard shaft; then loosen shaft lock and insert shaft into mounting hole, positioned so guard rests against fence (see **Figure 13**).
11. Position guard height as low as possible without dragging on infeed table/rabbeting ledge (approximately 1/16" above infeed table), tighten shaft lock to secure setting, then re-install button head cap screw and fender washer.
12. Verify proper operation of cutterhead guard by setting fence to 90°, moving fence to rear of table, then pulling cutterhead guard back and letting it go. It should spring back over cutterhead and contact fence without dragging across outfeed table.
 - If cutterhead guard does not spring back over cutterhead and contact fence, or if it drags across outfeed table, then it must be adjusted (refer to **Checking/Adjusting Cutterhead Guard** on Page 57 for instructions).

⚠ WARNING

The cutterhead guard is a critical safety feature of this jointer. You **MUST** verify its operation before using the jointer! Failure to properly install this guard will greatly increase risk of serious personal injury.

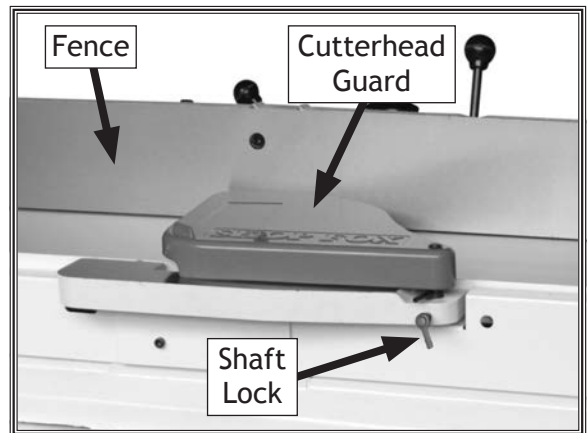

Figure 13. Cutterhead guard components.

Knife-Setting Jig (W1859)

Assemble the knife-setting jig (see **Figure 14**) using the knife-setting jig rod, feet, and e-clips.



Figure 14. Knife-setting jig assembly.

SETUP

Dust Collection

Recommended CFM at Dust Port: 400 CFM

Do not confuse this CFM recommendation with the rating of the dust collector. To determine the CFM at the dust port, you must consider these variables: (1) CFM rating of the dust collector, (2) hose type and length between the dust collector and the machine, (3) number of branches or wyes, and (4) amount of other open lines throughout the system. Explaining how to calculate these variables is beyond the scope of this manual. Consult an expert or purchase a good dust collection “how-to” book.

CAUTION

This machine creates substantial amounts of dust during operation. Breathing airborne dust on a regular basis can result in permanent respiratory illness. Reduce your risk by wearing a respirator and capturing the dust with a dust collection system.

SETUP

Item(s) Needed	Qty
Dust-Collection System	1
Dust Hose 4"	1
Hose Clamps 4"	2

To connect a dust-collection hose, do these steps:

1. Fit a 4" dust hose over the dust port, as shown in **Figure 15**, and secure it in place with a hose clamp.
2. Tug the hose to make sure it does not come off.

Note: A tight fit is necessary for proper performance.

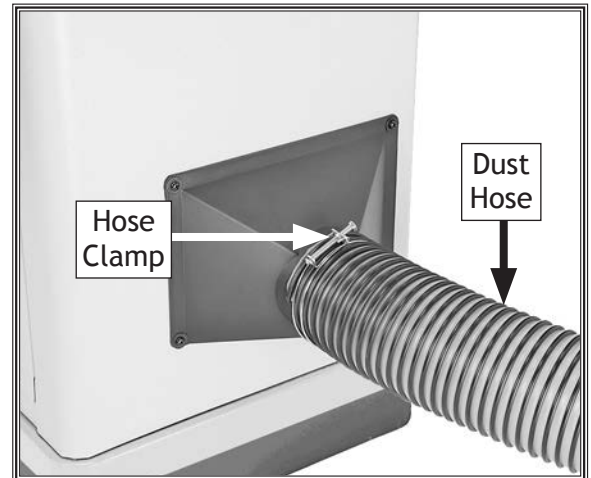

Figure 15. Example of dust hose connected to dust port.

Test Run

Once assembly is complete, test run the machine to ensure it is properly connected to power and safety components are functioning properly.

If you find an unusual problem during the test run, immediately stop the machine, disconnect it from power, and fix the problem BEFORE operating the machine again. The **Troubleshooting** table in the **SERVICE** section of this manual can help.

To test run machine, do these steps:

1. Clear all setup tools away from machine.
2. Connect machine to power supply.
3. Push ON button to start machine. A correctly operating machine runs smoothly with little or no vibration or rubbing noises.
4. Push STOP paddle to stop machine. Congratulations! The Test Run is complete.

Tensioning Belt

The final step in the setup process must be done after approximately 16 hours of operation. During this first 16 hours, the belt will stretch and seat into the pulley groove. After this time, you must re-tension the belt to avoid slippage and burn out. Refer to **Page 55** when you are ready to perform this important adjustment.

Note: *Pulleys and belt can get hot. This is a normal condition. Allow them to cool before making adjustments.*

A small amount of black belt dust at the bottom of the belt housing is normal during the life of the machine and does not indicate a problem with the machine or belt.

WARNING

Serious injury or death can result from using this machine BEFORE understanding its controls and related safety information. DO NOT operate, or allow others to operate, machine until the information is understood.

WARNING

DO NOT start machine until all preceding setup instructions have been performed. Operating an improperly set up machine may result in malfunction or unexpected results that can lead to serious injury, death, or machine/property damage.

Disabling & Locking Switch

!WARNING

Children or untrained people can be killed or seriously injured by this machine. This risk increases with unsupervised operation. To help prevent unsupervised operation, disable and lock the switch before leaving machine unattended! Place key in a well-hidden or secure location.

The switch can be disabled and locked by inserting a padlock through the ON/START button, as shown. Locking the switch in this manner can prevent unauthorized operation of the machine, which is especially important if the machine is not stored inside an access-restricted building.

IMPORTANT: Locking the switch with a padlock only restricts its function. It is not a substitute for disconnecting power from the machine when adjusting or servicing.

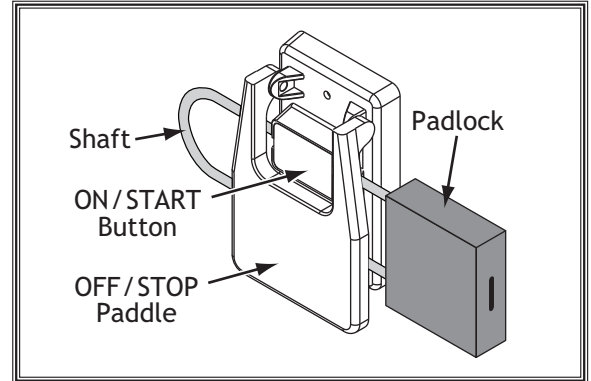

Figure 16. Switch disabled by padlock.

!WARNING

The padlock shaft diameter is important to the disabling function of the switch. Use padlocks with a maximum shaft diameter of 4mm. With any padlock used to lock the switch, test the switch after installation to ensure that it is properly disabled.

OPERATIONS

General

This machine will perform many types of operations that are beyond the scope of this manual. Many of these operations can be dangerous or deadly if performed incorrectly.

The instructions in this section are written with the understanding that the operator has the necessary knowledge and skills to operate this machine. If at any time you are experiencing difficulties performing any operation, stop using the machine!

The overview below provides the novice machine operator with a basic understanding of how the machine is used during operation, so the machine controls/components discussed later in this manual are easier to understand. Due to its generic nature, this overview is **NOT** intended to be an instructional guide.

To complete a typical operation with the jointer, the operator does the following:



1. Examines workpiece to verify it is safe and suitable for cutting.
2. Adjusts fence for width of workpiece and locks it in place.
3. Adjusts fence tilt, if necessary.
4. Adjusts infeed table height to set depth of cut per pass.
5. Puts on safety glasses, respirator, and any other required protective equipment.
6. Starts jointer.
7. Using push blocks as needed, holds workpiece firmly against infeed table and fence, and feeds workpiece into cutterhead at a steady and controlled rate until entire length of workpiece has been cut and it clears the cutterhead on the outfeed table side.
8. Repeats cutting process described above until desired results are achieved.
9. Stops jointer.

! WARNING



To reduce your risk of serious injury or damage to the machine, read this entire manual **BEFORE** using machine.

! WARNING

To reduce the risk of eye injury and long-term respiratory damage, always wear safety glasses and a respirator while operating this machine.

NOTICE

If you are an inexperienced operator, we strongly recommend that you read books or trade articles, or seek training from an experienced operator of this type of machinery before performing unfamiliar operations. Above all, safety must come first!

Stock Inspection

Follow these rules when choosing and jointing stock:

- **DO NOT joint or surface plane stock that contains large or loose knots.** Injury to the operator or damage to the workpiece can occur if a knot becomes dislodged during the cutting operation.
- **DO NOT joint or surface plane against the grain direction.** Cutting against the grain increases the likelihood of kickback, as well as tear-out on the workpiece.
- **Jointing and surface planing with the grain produces a better finish and is safer for the operator.** Cutting with the grain is described as feeding the stock on the jointer so the grain points down and toward you as viewed on the edge of the stock (see Figure below).

Note: If the grain changes direction along the edge of the board, decrease the cutting depth and make additional passes.

- **Scrape all glue off the workpiece before jointing.** Glue deposits on the workpiece, hard or soft, will gum up the cutterhead and produce poor results.
- **Remove foreign objects from the workpiece.** Make sure that any stock you process with the jointer is clean and free of dirt, nails, staples, tiny rocks or any other foreign objects that could damage the cutterhead. These particles could also cause a spark as they strike the cutterhead and create a fire hazard.

IMPORTANT: Wood stacked on a concrete or dirt surface can have small pieces of concrete or stone pressed into the surface.

- **Make sure all stock is sufficiently dried before jointing.** Wood with a moisture content over 20% will cause unnecessary wear on the cutters and poor cutting results. Excess moisture can also hasten rust and corrosion.

OPERATIONS

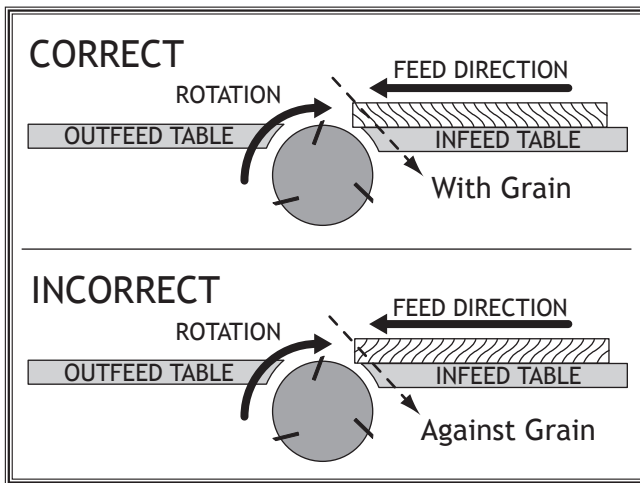

Figure 17. Proper grain alignment with cutterhead.

- **Only cut natural wood.** This jointer is only designed for cutting natural wood stock. Never use it to cut MDF, particle board, plywood, laminates, drywall, backer board, metals, glass, stone, tile, products with lead-based paint, or products that contain asbestos. Cutting these may lead to injury or machine damage.

⚠ WARNING

Make sure your workpiece exceeds the minimum dimension requirement shown below before processing it through the jointer, or the workpiece may break or kick back during the operation.

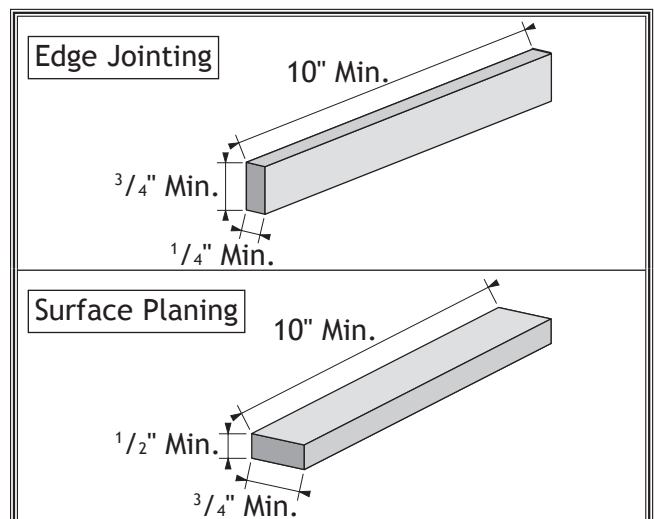

Figure 18. Minimum stock dimensions for jointer.

Squaring Stock

Squaring stock means making it flat and parallel along both length and width, and making the length and width perpendicular to one another.

The purpose of squaring stock is to prepare it for accurate cuts and construction later on.

A properly "squared up" workpiece is essential for tasks such as accurate table saw cuts, glue-ups/laminations, cutting accurate bevels on a bandsaw, and many other applications where one surface of a workpiece is used to reference another.

Item(s) Needed	Qty
Jointer	1
Planer	1
Table Saw	1

Squaring stock involves four steps performed in the order below:

1. **Surface Plane on Jointer**—Concave face of workpiece is surface planed flat with jointer.

2. **Surface Plane on a Thickness Planer**—Opposite face of workpiece is surface planed flat with a thickness planer.

3. **Edge Joint on Jointer**—Concave edge of workpiece is jointed flat with jointer.

4. **Rip Cut on a Table Saw**—Jointed edge of workpiece is placed against a table saw fence and opposite edge cut off.

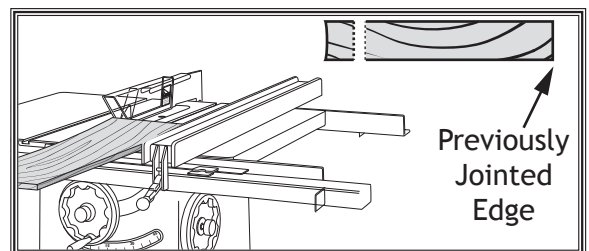
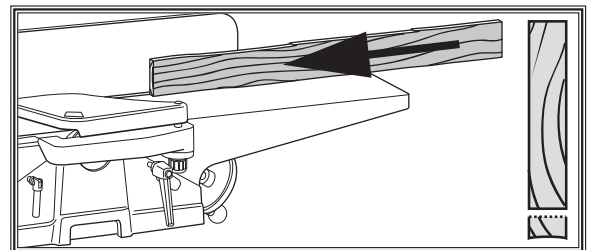
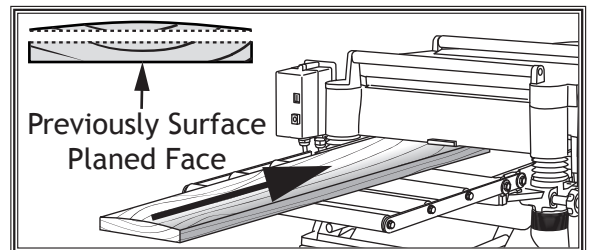
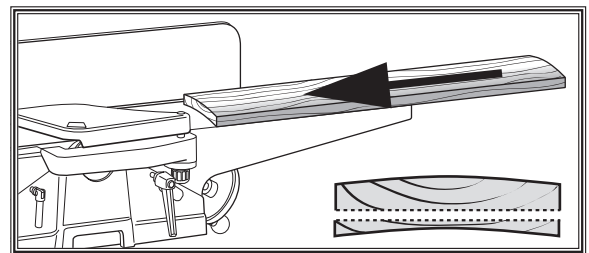

OPERATIONS

Surface Planing

The purpose of surface planing (see **Figure 19**) on the jointer is to make one flat face on a piece of stock to prepare it for thickness planing on a planer.

To surface plane on jointer, do these steps:

1. Inspect stock to ensure it is safe and suitable for the operation (refer to **Stock Inspection** on **Page 26**).
2. Set infeed table height to desired cutting depth for each pass.
 - ▲ **CAUTION:** To minimize risk of kickback, do not exceed a cutting depth of $\frac{1}{16}$ " per pass when surface planing.
3. Set fence to 90° .
4. Start jointer.
5. Place workpiece firmly against fence and infeed table with concave side facing down, as shown in **Figure 19**.

▲ **CAUTION:** To ensure workpiece remains stable during cut, concave sides of workpiece must face toward table and fence.

6. Feed workpiece completely across cutterhead while keeping it firmly against fence and tables during the entire cut.

▲ **CAUTION:** Keep hands at least 4" away from cutterhead during the entire cut. Instead of allowing a hand to pass directly over cutterhead, lift it up and over cutterhead, and safely reposition it on the outfeed side to continue supporting workpiece. Use push blocks whenever practical to further reduce risk of accidental hand contact with cutterhead.

7. Repeat **Step 6** until entire surface is flat.

Tip: When squaring up stock, cut opposite side of workpiece with a planer instead of the jointer to ensure both sides are parallel.

WARNING

Failure to use push blocks when surface planing could result in your hands contacting rotating cutterhead, which will cause serious personal injury. ALWAYS use push blocks when surface planing on jointer!

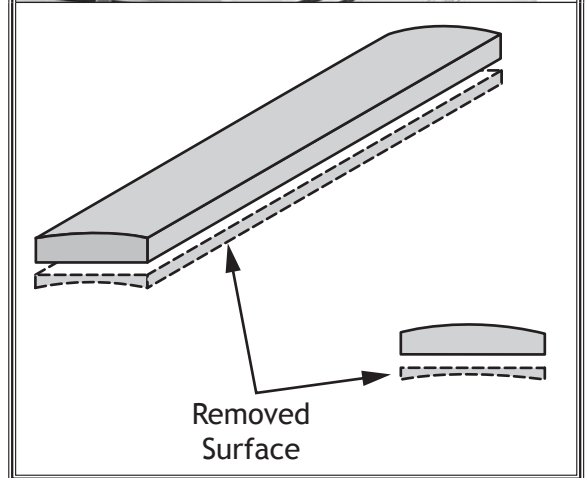

Figure 19. Example of a typical surface planing operation.

Edge Jointing

Edge jointing (see **Figure 20**) produces a flat and true surface along the side of a workpiece by removing uneven areas. It is an essential step for squaring up warped or rough stock and when preparing a workpiece for joinery or finishing.

To edge joint on jointer, do these steps:

1. Inspect stock to ensure it is safe and suitable for the operation (refer to **Stock Inspection** on **Page 26**).
2. Surface plane workpiece (refer to **Surface Planing** on **Page 28**).
3. Set infeed table height to desired cutting depth for each pass.

⚠ CAUTION: To minimize risk of kickback, do not exceed a cutting depth of $\frac{1}{8}$ " per pass.

4. Set fence to 90° .
5. Start jointer.
6. Place workpiece firmly against fence and infeed table with concave side facing down, as shown in **Figure 20**.

⚠ CAUTION: To ensure workpiece remains stable during cut, concave sides of workpiece must face toward table and fence.

7. Feed workpiece completely across cutterhead while keeping it firmly against fence and tables during the entire cut.

⚠ CAUTION: Keep hands at least 4" away from cutterhead during the entire cut. Instead of allowing a hand to pass directly over cutterhead, lift it up and over cutterhead, and safely reposition it on the outfeed side to continue supporting workpiece. Use push blocks whenever practical to further reduce risk of accidental hand contact with cutterhead.

8. Repeat **Step 6** until the entire edge is flat.

Tip: When squaring up stock, cut opposite edge of workpiece with a table saw instead of the jointer—otherwise, both edges of workpiece will not be parallel with each other.

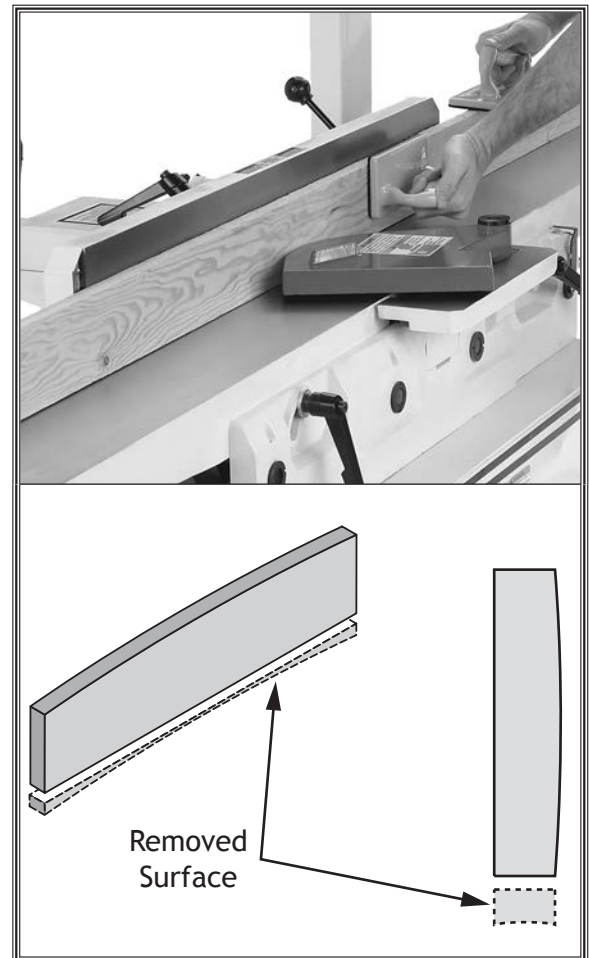

Figure 20. Example of a typical edge jointing operation.

Bevel Cutting

Bevel cuts (see **Figure 21**) can be made by setting the fence at the desired angle and feeding the workpiece firmly along the fence face, with the bottom inside corner firmly against the table. The cutting process typically requires multiple passes or cuts to bevel the entire edge of a workpiece.

To bevel cut on jointer, do these steps:

1. Inspect stock to ensure it is safe and suitable for the operation (refer to **Stock Inspection** on **Page 26**).
2. Surface plane workpiece (refer to **Surface Planing** on **Page 28**).
3. Edge joint workpiece (refer to **Edge Jointing** on **Page 29**).
4. Set infeed table height to cutting depth desired for each pass.

⚠ CAUTION: Cutting depth for bevel cuts is typically between $\frac{1}{16}$ " and $\frac{1}{8}$ ", depending on hardness and width of stock.

5. Set fence tilt to desired angle of cut.
6. Place workpiece against fence and infeed table.
7. Start jointer.
8. With a push block in your leading hand, press workpiece against table and fence with firm pressure, and feed workpiece over cutterhead with a push block in your trailing hand.

⚠ CAUTION: When your leading hand gets within 4" of the cutterhead, lift it up and over cutterhead, and place push block on portion of the workpiece once it is 4" past cutterhead. Now, focus your pressure on outfeed end of the workpiece while feeding, and repeat same action with your trailing hand when it gets within 4" of cutterhead. To help keep your hands safe, **DO NOT** let them get closer than 4" from moving cutterhead at any time during operation!

9. Repeat cutting process, as necessary, until you are satisfied with the results.

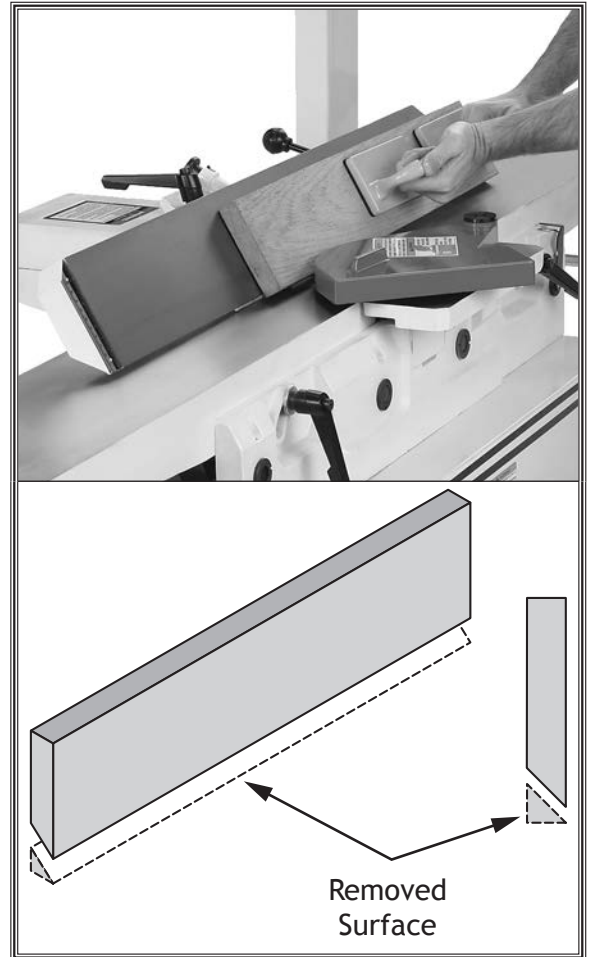

Figure 21. Example of a 45° bevel cutting operation.

Rabbet Cutting

A rabbet cut removes a portion of a workpiece edge, so it fits together with an opposing, equally sized rabbet cut on another workpiece (see **Figures 22–23**). This is a classic method of joining two workpieces that is simple, yet strong.

This jointer can be used to make high-quality rabbet cuts, but there are some situations—whether it is due to an excessively large/small workpiece size or rabbet cutting width/depth—when it will not be safe or appropriate for making the rabbet cut on this jointer. In these cases, you need to use another tool or method for rabbet cutting that will be a safer alternative.

A rabbet cut can alternatively be made using a table saw, router, or even a hand saw. As with any type of cutting operation, always consider your safety first and use good judgement!

Typically, rabbet cutting with a jointer requires the cutterhead guard to be removed first, so the workpiece can slide along the rabbeting ledge during the cut. However, it is possible to make rabbet cuts with workpieces up to 1" thick without removing the cutterhead guard. This is done by performing the rabbet cut with the workpiece on end (similar to when you are edge jointing).

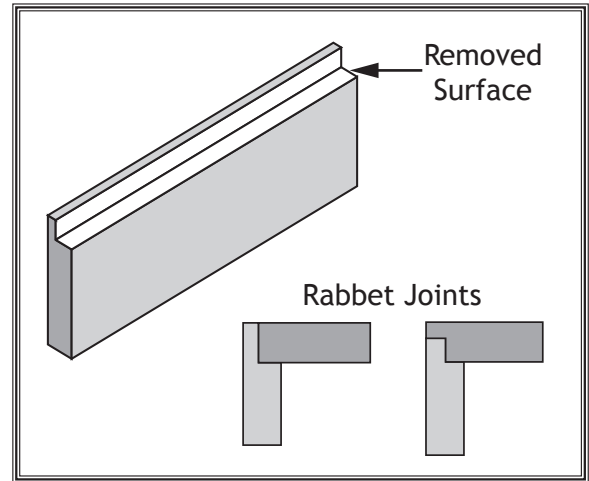

Figure 22. Rabbet joints.

To rabbet cut on jointer, do these steps:

1. Inspect stock to ensure it is safe and suitable for the operation (refer to **Stock Inspection** on **Page 26**).
2. Surface plane workpiece (refer to **Surface Planing** on **Page 28**).
3. Edge joint workpiece (refer to **Edge Jointing** on **Page 29**).
4. Set infeed table height to desired cutting depth for each pass.

▲ CAUTION: For safety reasons, cutting depth should never exceed $\frac{1}{8}$ " per pass.

5. Remove cutterhead guard if necessary to perform operation (see **Figure 22**).
6. Set fence to 90° and near front of jointer, so amount of exposed cutterhead in front of fence matches size of desired rabbet.
7. Start jointer.
8. Place workpiece firmly against fence and infeed table.
9. Feed workpiece completely across cutterhead while keeping it firmly against fence and tables during entire cut.

▲ CAUTION: Keep hands at least 4" away from cutterhead during the entire cut. Instead of allowing a hand to pass directly over cutterhead, lift it up and over cutterhead, and safely reposition it on the outfeed side to continue supporting workpiece. Use push blocks whenever practical to further reduce risk of accidental hand contact with cutterhead.

10. Repeat **Step 7** until rabbet is cut to depth.
11. Re-install cutterhead guard if removed in **Step 3**.

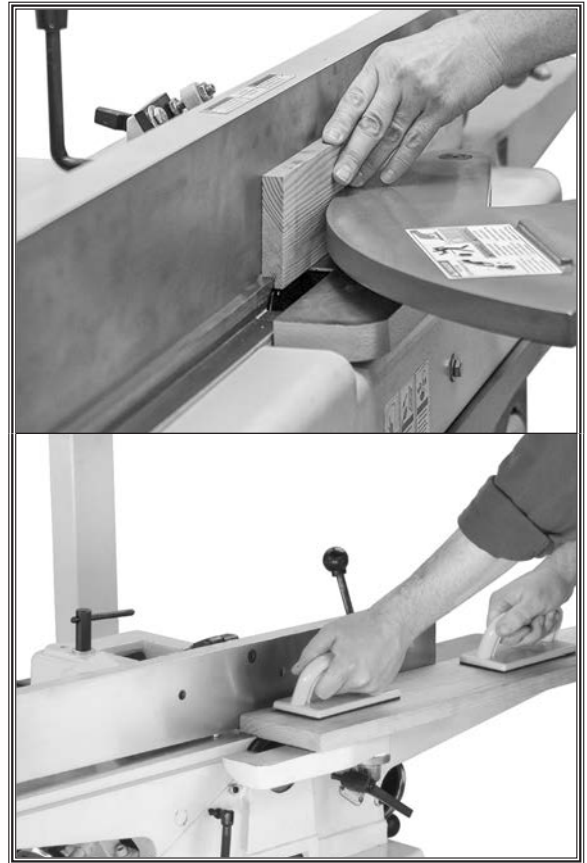

Figure 23. Examples of typical rabbet cutting operations.

Setting Depth of Cut

The depth of cut on a jointer affects the amount of material removed from the bottom of the workpiece as it passes over the cutterhead.

The depth of cut is set by adjusting the height of the infeed table relative to the outfeed table and cutterhead knives/inserts at top dead center (TDC).

This jointer is equipped with a 1/8" infeed table stop. This prevents the table from accidentally being lowered below 1/8", which is the maximum depth of cut for surface planing and edge jointing.

Adjusting Infeed Table Height

To adjust the infeed table height, loosen the infeed table lock (see **Figure 24**), move the infeed table adjustment lever (see **Figure 24**) up or down to raise or lower the table, and then tighten the lock to secure the setting.

To lower the infeed table below 1/8" stop, pull the table release knob (see **Figure 24**), adjust the table height, and then tighten the lock to secure the setting.

Depth-of-Cut Scale

The depth of cut can be referenced directly from the scale located on the front of the jointer (see **Figure 25**).

Note: The depth-of-cut scale can be calibrated or "zeroed" if it is not accurate. (Refer to *Calibrating Depth-of-Cut Scale* on Page 54.)

⚠ CAUTION

DO NOT exceed 1/8" depth of cut per pass on this machine or kickback and serious injury may occur!

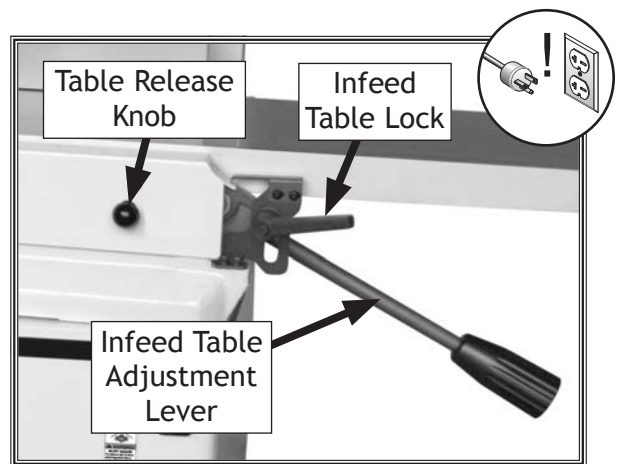

Figure 24. Infeed table controls.

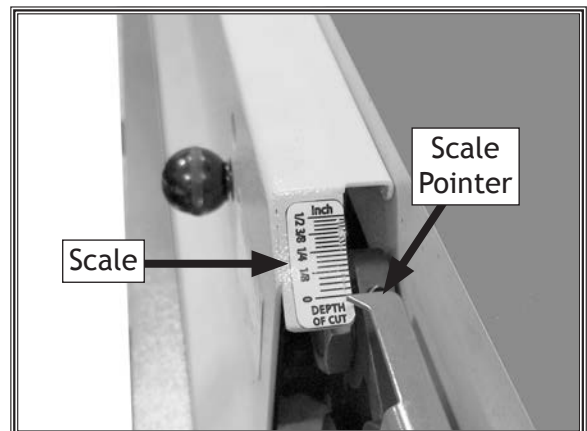

Figure 25. Depth-of-cut scale components.

Infeed Positive Stops

The infeed table has three positive stop bolts (see **Figure 26**) that allow you to quickly adjust the infeed table between finish/final cuts and shaping/heavy cuts, and the maximum depth of cut of $\frac{1}{2}$ " (or less) when rabbeting.

The positive stop bolts control the top and bottom range of table movement. Jam nuts lock the positive stop bolts in position so they will not move during operation.

We recommend setting the bottom height stop bolt at $\frac{1}{2}$ ". The top height stop can be set anywhere between 0" and $\frac{1}{16}$ ". The $\frac{1}{8}$ " depth stop is factory set and should not be adjusted unless calibration is necessary.

Item(s) Needed	Qty
Open-End Wrench 13mm.....	1

To adjust infeed positive stop bolts, do these steps:

1. DISCONNECT MACHINE FROM POWER!
2. Loosen jam nuts on both stop bolts (see **Figure 26**).
3. Raise table to minimum desired depth of cut, then tighten top height stop bolt (see **Figure 26**) until it contacts table. Tighten jam nut to secure stop bolt in position.
4. Lower table to maximum desired depth of cut, then tighten bottom height stop bolt until it contacts table. Tighten jam nut to secure stop bolt in position.

Note: If you need to lower the infeed table more than $\frac{1}{8}$ ", then pull and hold the table release knob (see **Figure 24** on **Page 33**) while lowering infeed table.

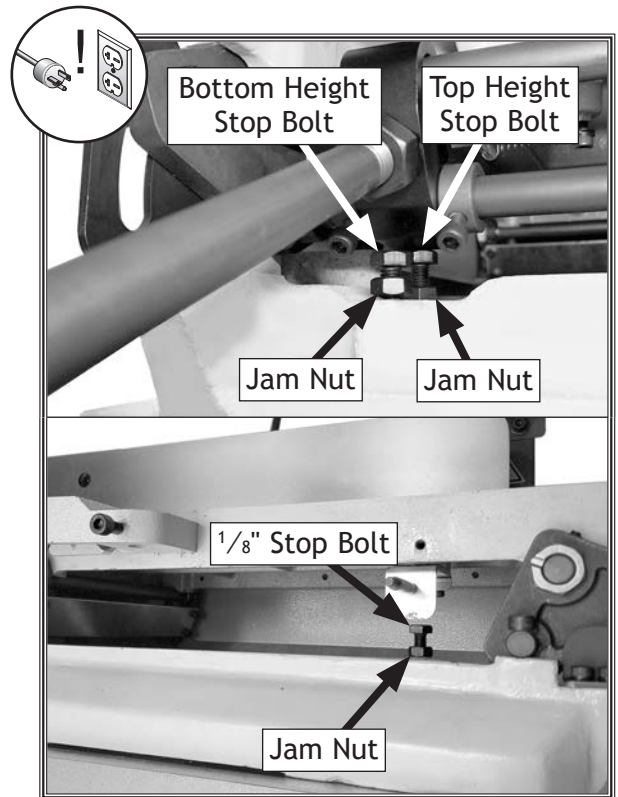

Figure 26. Positive stop bolts for infeed table.

ACCESSORIES

Jointer Accessories

The following jointer accessories may be available through your local Woodstock International Inc. Dealer. If you do not have a dealer in your area, these products are also available through online dealers. Please call or e-mail Woodstock International Inc. Customer Service to get a current listing of dealers at: 1-800-840-8420 or at sales@woodstockint.com.

D1123—Jointer/Planer Knife Hone

This handy tool sharpens flat and beveled surfaces quickly and easily. Great for touch-ups.



W1211A—Jointer Pal® Magnetic Knife Gauge (For HSS & Cobalt Knives)

This magnetic knife-setting system lets you set jointer knives in perfect alignment every time!

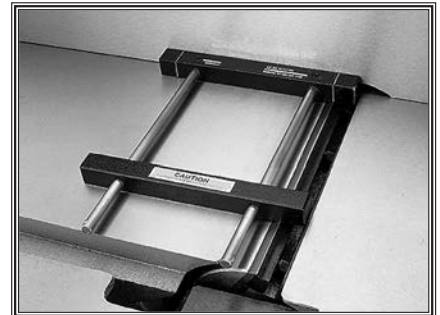

D3634—HSS Jointer Knives, 4 Pk.

8" x 3/4" x 1/8" replacement HSS jointer knives for Model W1859.

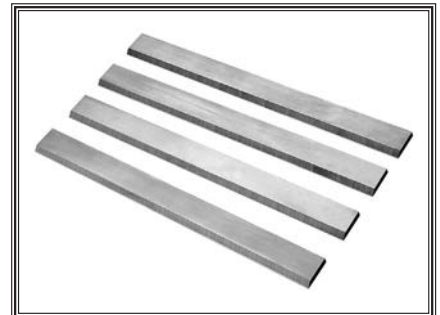

D4297—Indexable Carbide Inserts, 10-Pk.

15 x 15 x 2.5mm replacement indexable carbide inserts for Model W1860.

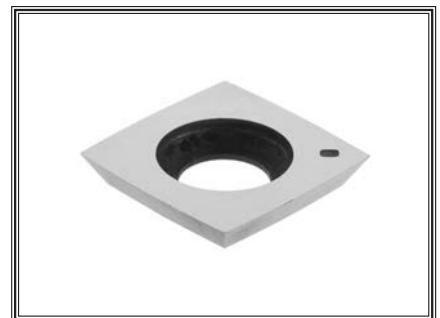

- D4206—Clear Flexible Hose 4" x 10'
- D4256—45° Elbow 4"
- W1007—Plastic Blast Gate 4"
- W1017—90° Elbow 4"
- D4216—Black Flexible Hose 4" x 10'
- W1053—Anti-Static Grounding Kit
- W1317—Wire Hose Clamp 4"

We've handpicked a selection of commonly used dust-collection components for machines with 4" dust ports.



W1727—1 HP Dust Collector

Specifications: • 1 HP, 120V/240V, single-phase motor • 800 CFM air suction capacity • 5.67" static pressure • One 4" intake hole • 9" balanced steel, radial fin impeller • 2.1 cubic feet of bag capacity • 15³/₄" x 39³/₄" base on casters for portability • 2.5-micron bag filtration • Power-coated finish for durability • 54¹/₂" height with bag inflated.



MAINTENANCE

General

For optimum performance from this machine, this maintenance schedule must be strictly followed.

Ongoing

To maintain a low risk of injury and proper machine operation, if you ever observe any of the items below, shut down the machine immediately and fix the problem before continuing operations:

- Loose mounting bolts.
- Dust or debris on and around machine.
- Dull or damaged cutterhead knives/inserts.
- Unprotected cast-iron surfaces.
- Worn or damaged wires.
- Any other unsafe condition.

Monthly Check

- Clean and lubricate fence pivot points (**Page 38**).
- V-belt tension, damage, or wear.
- Clean/vacuum dust buildup from inside stand and off of motor.

Cleaning & Protecting

Cleaning the Model W1859/W1860 is relatively easy. Vacuum excess wood chips and sawdust, and wipe off the remaining dust with a dry cloth. If any resin has built up, use a resin dissolving cleaner to remove it.

Protect the unpainted cast iron table by wiping it clean after every use—this ensures moisture from wood dust does not remain on bare metal surfaces. Keep your table rust-free with regular applications of quality lubricants.

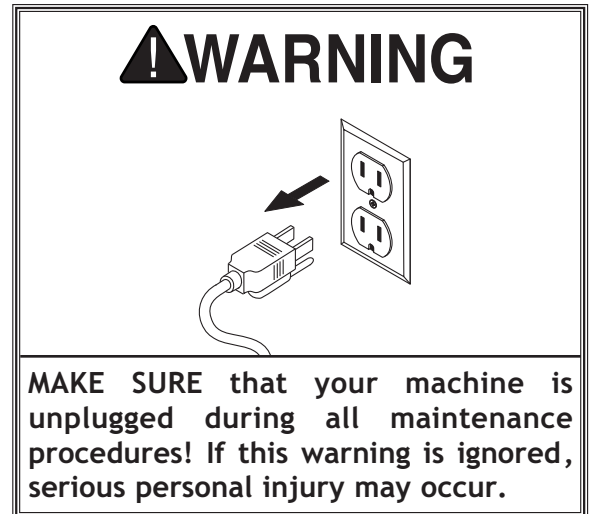

Lubrication

Since all bearings are sealed and permanently lubricated, simply leave them alone until they need to be replaced. DO NOT lubricate them.

It is essential to clean components before lubricating them because dust and chips build up on lubricated components and make them hard to move. Simply adding more grease to them will not yield smooth-moving components.

Item(s) Needed	Qty
Pump-Type Oil Can	1
Mineral Spirits	As Needed
Clean Shop Rags.....	As Needed

Fence & Carriage

Oil Type.....	ISO 68 Equivalent
Oil Amount	1-2 Drops
Lubrication Frequency	Monthly, or As Needed

Clean fence pivot points and carriage ways (see **Figure 27**) with mineral spirits and shop rags, allow to dry, then lubricate with light machine oil. Wipe off excess oil.

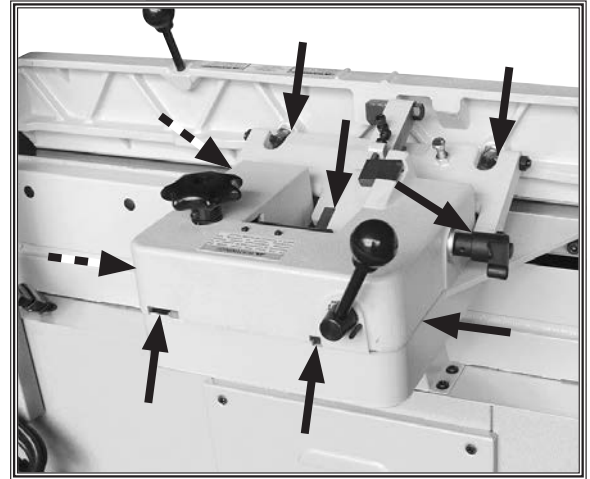

Figure 27. Fence and carriage lubrication locations.

SERVICE

General

This section covers the most common service adjustments or procedures that may need to be made during the life of your machine.

If you require additional machine service not included in this section, please contact Woodstock International Technical Support at (360) 734-3482 or send e-mail to: techsupport@woodstockint.com.

Setting/Replacing Knives (W1859)

Setting the knives correctly is crucial to the proper operation of the jointer and it plays an important role in keeping the knives sharp. If one knife is higher than the others, it will do the majority of the work, and thus, become dull much faster.

The cutterhead on this jointer comes with both jack screws and springs for setting knife height. Which one you choose is a matter of personal preference. However, *only one of these options is needed to set the knives.* The advantage of using springs is that springs maintain a constant upward pressure on the knives while using the knife-setting jig. The advantage of using jack screws is that once you set the proper height of the screws, they should require little to no adjustment when replacing knives.

There are two options for setting the knives—the straightedge method and the knife-setting jig method. Each option has advantages and disadvantages; the correct one for you will be a matter of personal preference. For best results, the tables must be parallel with each other (refer to **Checking/Adjusting Table Parallelism**) and the outfeed table height must be properly set (refer to **Setting Outfeed Table Height**).

! WARNING

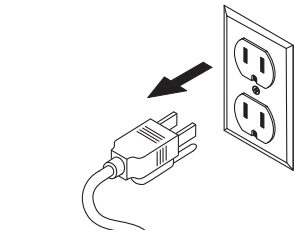

MAKE SURE that your machine is unplugged during all service procedures! If this warning is ignored, serious personal injury may occur.

! CAUTION

The HSS knives are very sharp and can quickly cut your hands. ALWAYS use caution when handling these parts to reduce risk of personal injury.

Straightedge Method

A high quality straightedge (or Jointer Pal) is held flat against the outfeed table and the knife heights are set to the bottom of the straightedge, as shown in **Figures 28–29**. Because the knife projection height from the cutterhead is dependent on the outfeed table height, the outfeed table must be set as described in **Setting Outfeed Table Height** on **Page 49** for this method to work correctly.

When using the straightedge method to set the knives, you will not need to move the outfeed table once it is set and you will always be assured that the knives are even with the outfeed table in their highest point of rotation—top dead center (TDC)—even if the cutterhead is not perfectly parallel with the outfeed table.

Item(s) Needed	Qty
Precision Straightedge or Knife-Setting Jig	1
Hex Wrench 3mm	1
Open-End Wrench 10mm.....	1

To check knife height with a straightedge, do these steps:

1. DISCONNECT MACHINE FROM POWER!
2. Remove cutterhead guard or block it open.
3. Using a straightedge on outfeed table, check height of each knife at positions as shown in **Figure 28**.
 - Knives are set correctly when they just touch bottom of straightedge at TDC in each of straightedge positions.
 - If knives do not touch straightedge or they lift up at any position, then those knives need to be adjusted (refer to **Setting/Replacing Knives** on **Page 42**).

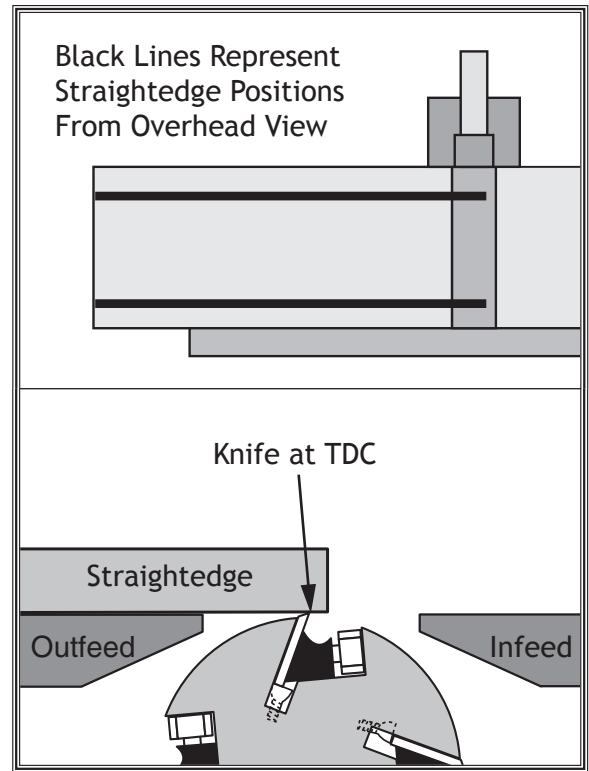

Figure 28. Setting knife height with a straightedge.



Figure 29. Setting knife height with a Jointer Pal®.

Knife-Setting Jig Method

The infeed table is lowered to fit the jig on the cutterhead, as shown in **Figure 30**, and the knife heights are set to just touch the middle pad of the jig. The knife-setting jig included with the jointer is designed to set all the knives evenly and at the correct height in the cutterhead.

To check knife height with a knife-setting jig, do these steps:

1. DISCONNECT MACHINE FROM POWER!
2. Remove cutterhead guard or block it open.
3. Pull table release knob and lower infeed table to $\frac{1}{2}$ " scale mark.
4. Rotate cutterhead so knife is at top dead center (TDC).
5. Place knife jig on cutterhead, directly over a knife.
6. Closely examine how jig touches cutterhead and knife. Knife is set correctly when, on each side of cutterhead, both legs of jig sit firmly on cutterhead body and middle pad of jig just touches top edge of knife.
 - If jig does not sit as described, then that knife must be reset. Repeat this inspection with other knives before resetting. (Refer to **Setting/Replacing Knives** on **Page 42**.)

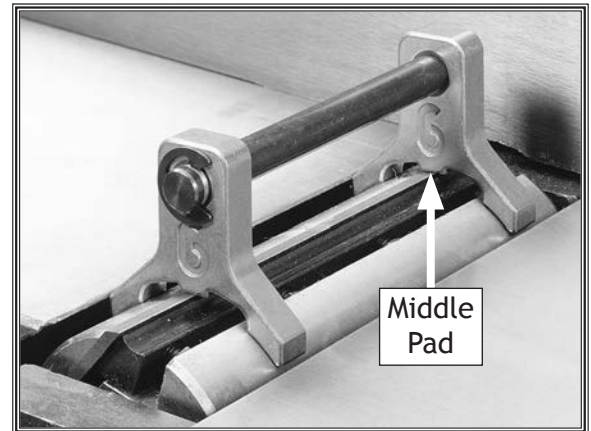

Figure 30. Example of knife-setting jig positioned over cutterhead knife.

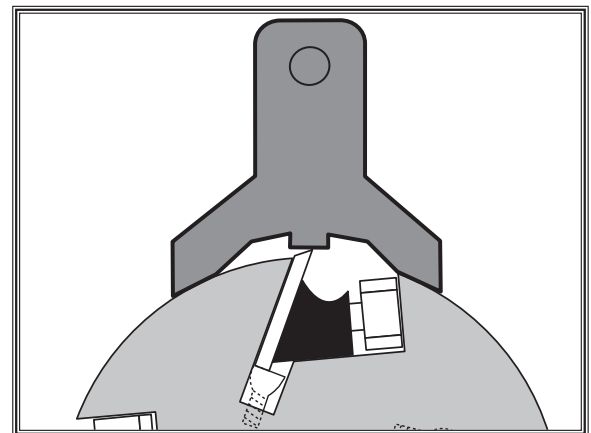

Figure 31. Using knife-setting jig to check knife height.

Setting/Replacing Knives

1. DISCONNECT MACHINE FROM POWER!
2. Remove cutterhead guard from table and lower infeed table to $\frac{1}{2}$ " on depth-of-cut scale. This will provide unrestricted access to cutterhead.
3. Remove cabinet rear access panel to expose cutterhead pulley.
4. Rotate cutterhead pulley to provide good access to cutterhead knives.
5. Loosen cutterhead gib bolts (see **Figure 32**), starting in the middle, and alternating back and forth until all gib bolts are loose, but not falling out.

The first time you set or replace a knife, remove the gib and knife from cutterhead. Clean gib and clean inside cutterhead slot to remove all pitch or sawdust. Coat knife and gib with a metal protectant.

6. Position knife-setting jig over knife. Loosen gib bolts until knife is completely loose.
7. **Jack Screws**—Access jack screws through holes in cutterhead (see **Figure 33**). Using a hex wrench, rotate jack screws to raise or lower knife. When knife is set correctly, it will barely touch the bottom of the straightedge or the middle pad of the knife jig. Snug gib bolts just tight enough to hold knife in place. Repeat with remaining knives.

Springs—Push knife down with straightedge or middle pad of knife-setting jig (see **Figure 34**). Keep straightedge flat against outfeed table. If using jig, keep feet pressed evenly against cutterhead. Tighten gib bolts just enough to hold knife in place. Repeat with remaining knives.

8. Rotate cutterhead to reveal the first knife you started with. Lightly snug all gib bolts, alternating from one side to the other, and working from the ends to the middle. Repeat with remaining knives.
9. Tighten each gib bolt in the same alternating manner as you did in the previous step.
10. Make sure outfeed table is set even with the new knives at top dead center.
11. Replace cutterhead guard and cabinet rear access panel.

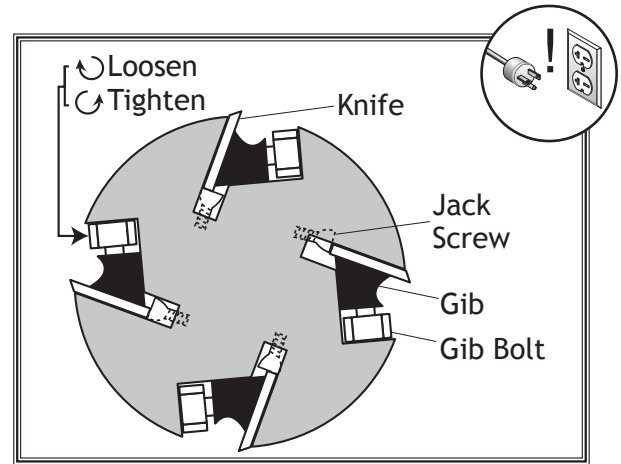

Figure 32. Cutterhead profile diagram.

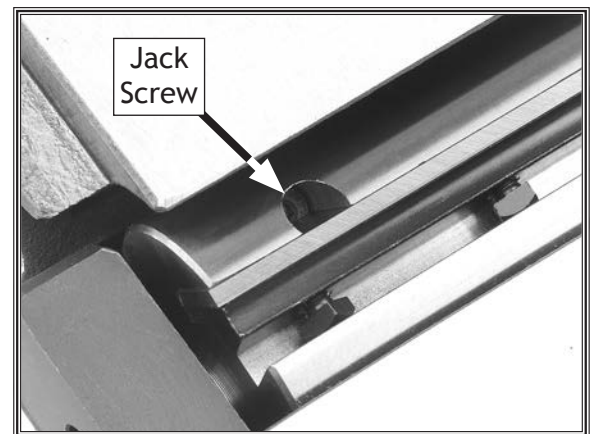

Figure 33. Location of jack screw access hole.

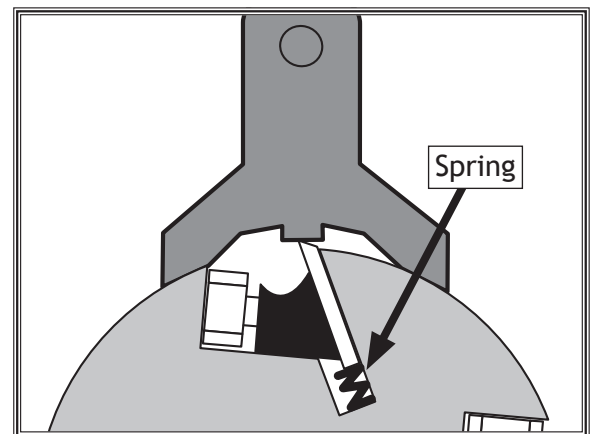

Figure 34. Location of spring.

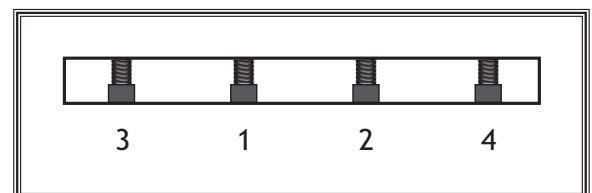

Figure 35. Gib bolt tightening sequence.

Rotating/Replacing Helical Cutterhead Inserts (W1860)

The helical cutterhead is equipped with 4-sided indexable carbide inserts. Each insert can be removed, rotated, and re-installed to use any one of its four cutting edges. Therefore, if one cutting edge becomes dull or damaged, simply rotate it 90° (see **Figure 36**) to use a sharp cutting edge.

The inserts have a reference dot on one corner. The position of the reference dot on installed inserts can be used to track which edges are sharp/unused and which edges are dull or damaged. Replace inserts once the reference dot has been rotated back to its original position.

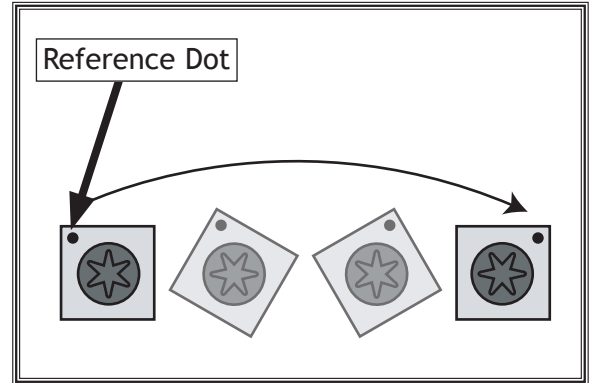

Figure 36. Insert rotating sequence.

Item(s) Needed

	Qty
Carbide Inserts 15 x 15 x 2.5mm.....	As Needed
Torx Head Screws T-25 #10-32 x 1/2".....	As Needed
T-25 Torx Driver or Torque Wrench.....	1
T-25 Torx Bit	1

To rotate or replace helical cutterhead insert, do these steps:

1. DISCONNECT MACHINE FROM POWER!
2. Remove cutterhead guard from table, and then pull table release knob and lower infeed table as far down as it will go.
3. Remove cover to get access to cutterhead pulley.
4. Taking care not to pinch your hand between belt and pulley, rotate pulley as needed to make inserts accessible for removal.

⚠ CAUTION

The carbide inserts are very sharp and can easily cut your hands. **ALWAYS** use caution when handling these parts to reduce risk of personal injury.

5. Carefully clean away all sawdust or debris from top of insert, Torx screw, and surrounding area (see Figure 37).
6. Remove Torx screw and insert, then carefully clean away all dust and debris from insert and insert pocket in cutterhead.

IMPORTANT: This step is critical for achieving a smooth finish with cutting operations. Dirt or dust trapped under insert during installation will slightly raise insert in cutterhead, which will leave marks on workpiece after jointing.

Tip: Use low-pressure compressed air or a vacuum nozzle to clean cutterhead pocket.

7. Re-install insert with a sharp cutting edge facing outward. Make sure insert is properly seated in cutterhead pocket before securing.
 - If all four insert cutting edges have been used, replace insert with a new one. Always position reference dot in same position when installing a new insert to aid in rotational sequencing.
8. Lubricate Torx screw threads with a small amount of light machine oil, wipe excess off, and torque screw to 48-50 inch/pounds.

IMPORTANT: If too much oil is applied to the threads, excess will attempt to squeeze out of threaded hole as you install insert and force it to raise slightly, making it out of alignment.

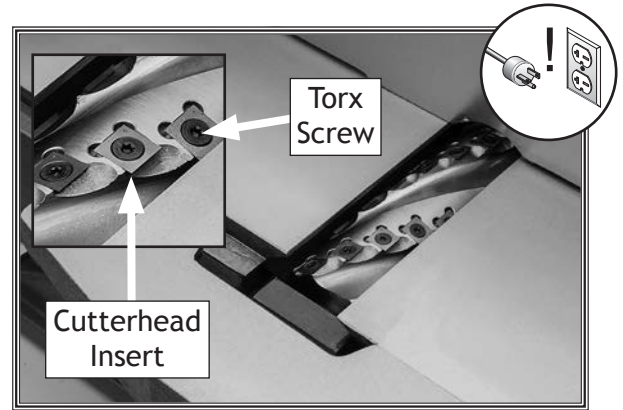

Figure 37. Example of cutterhead inserts and Torx screws.

Checking/Adjusting Table Parallelism

If the tables are not parallel with the cutterhead and each other, then poor cutting results and kickback can occur.

Item(s) Needed	Qty
Precision Straightedge 3'.....	1
Open-End Wrench 16mm.....	1
Hex Wrenches 3, 5mm	1 Ea.

Checking Outfeed Table

1. DISCONNECT MACHINE FROM POWER!
2. Remove cutterhead guard, fence assembly, and rear access panel on stand.
3. Loosen outfeed table lock located at front of machine, and loosen jam nuts and stop bolts located under outfeed table (see **Figure 38**).
4. Rotate motor pulley so that you can access cutterhead body with straightedge between the knives/inserts, as shown in **Figure 39**.
5. Place straightedge on outfeed table so it hangs over cutterhead, then lower outfeed table until straightedge just touches cutterhead body.
6. Place straightedge in positions shown in **Figure 40**. In each position, straightedge should touch cutterhead and sit flat on outfeed table.
 - If straightedge touches cutterhead body and sits flat across outfeed table in all positions, then outfeed table is already parallel with cutterhead. Follow the **Checking Infeed Table** instructions on **Page 46**.
 - If straightedge *does not* touch cutterhead body and sit flat across outfeed table in any of the positions, then outfeed table is not parallel with cutterhead. Perform **Adjusting Table Parallelism** procedure on **Page 47**, then perform **Checking Infeed Table** procedure on **Page 46**.

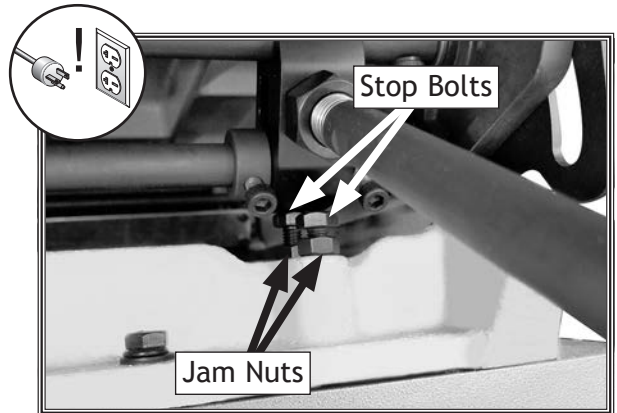

Figure 38. Location of outfeed table stop bolts and jam nuts.

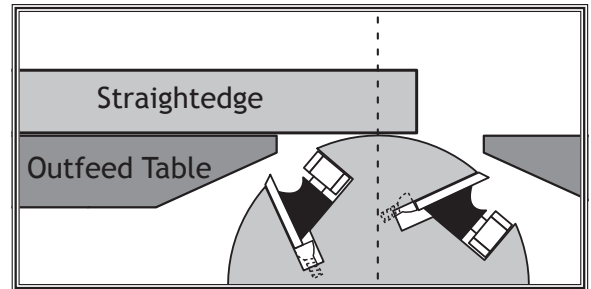

Figure 39. Adjusting outfeed table even with cutterhead body (knife-style cutterhead shown).

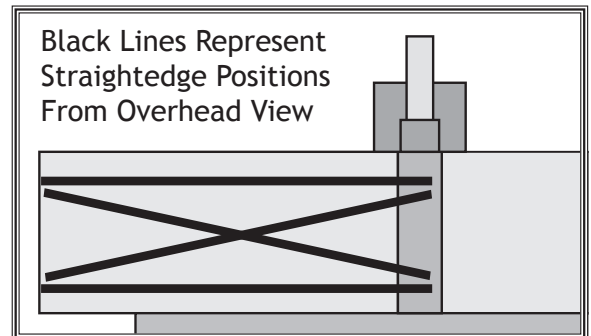

Figure 40. Straightedge positions for verifying if the outfeed table is parallel with cutterhead.

SERVICE

Checking Infeed Table

1. Follow all steps for checking outfeed table parallelism to first make sure that outfeed table is parallel with cutterhead.
2. Set outfeed table height (refer to **Setting Outfeed Table Height on Page 49**).
3. Rotate cutterhead so knives/inserts will not interfere, then place straightedge on infeed and outfeed tables and adjust infeed table even with outfeed table, as shown in **Figure 41**.
4. Place straightedge in the positions shown in **Figure 42**. In each position, straightedge should sit flat against both outfeed table and infeed table.
 - If straightedge sits flat against both infeed and outfeed tables in all positions, then tables are parallel. Replace cutterhead guard, fence assembly, and rear access panel on stand.
 - If straightedge *does not* sit flat against both infeed and outfeed tables in any of the positions, then perform **Adjusting Table Parallelism on Page 47**.

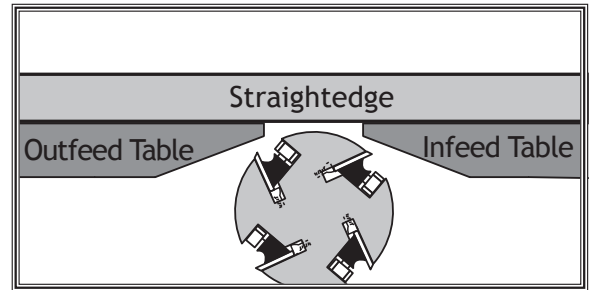

Figure 41. Infeed and outfeed tables set evenly (knife-style cutterhead shown).

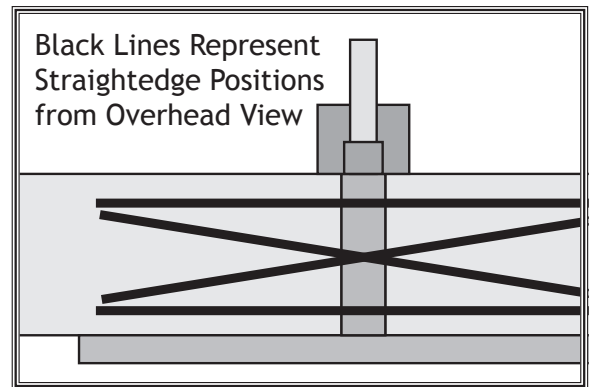

Figure 42. Straightedge positions for checking infeed/outfeed table parallelism.

Adjusting Table Parallelism

For safe and proper cutting results, the tables must be parallel to the cutterhead. Adjusting them to be parallel is a task of precision and patience, and may take up to one hour to complete. Luckily, this is considered a permanent adjustment and should not need to be repeated for the life of the machine.

Due to the complex nature of this task, we recommend that you double check the current table positions to make sure that they really need to be adjusted before starting.

Each table has four eccentric bushings on the base underneath that allow the table to be adjusted parallel. Each bushing is locked in place by a set screw.

The correct order for adjusting the table parallelism is to first adjust the outfeed table parallel with the cutterhead, then adjust the infeed table parallel with the outfeed table.

When setting the outfeed table, all measurements **MUST** be made from the cutterhead body—not the knives/inserts or the results may be skewed.

IMPORTANT: The following steps are intended to be performed directly after the steps involved in **Checking Outfeed Table**. Do not continue until you have performed those steps.

To adjust table parallelism, do these steps:

1. Place straightedge on outfeed table so it hangs over cutterhead, and lower outfeed table until straightedge just touches cutterhead body, as shown in **Figure 43**.
2. Remove outfeed table covers by removing plugs (see **Figure 44**) and accessing cap screws that secure covers to table, and then loosen set screws from eccentric bolts under outfeed table (see **Figure 44**).

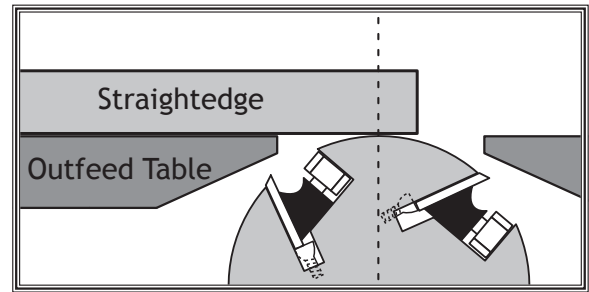

Figure 43. Adjusting outfeed table even with cutterhead body (knife-style cutterhead shown).

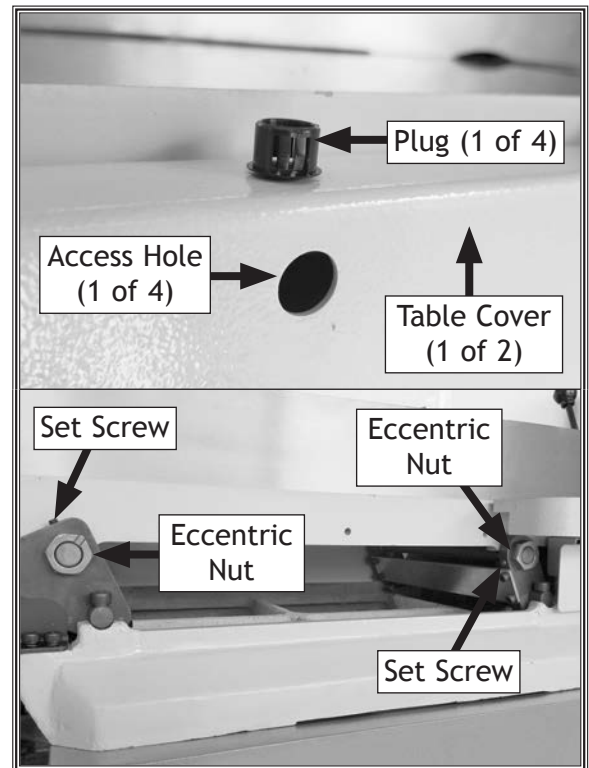

Figure 44. Accessing outfeed eccentric bushings (2 of 4).

3. Place straightedge in one of the positions shown in **Figure 45**, and adjust eccentric bushings so straightedge touches cutterhead body while lying flat across outfeed table (a small hammer and punch may be necessary to turn eccentric bushings).
4. Repeat **Step 3** with each remaining straightedge position as many times as necessary until outfeed table is parallel with cutterhead.
5. Tighten set screws in eccentric bushings on outfeed table.
6. Remove $\frac{1}{8}$ " stop release knob and infeed table covers and loosen set screws from each eccentric bushings under infeed table.
7. Place straightedge halfway across infeed and outfeed tables, and adjust infeed table even with outfeed table, as shown in **Figure 46**.
8. Place straightedge in one of the positions shown in **Figure 47**, and adjust eccentric bushings under infeed table so straightedge lies flat against both tables.
9. Repeat **Step 8** with each remaining straightedge position as many times as necessary until infeed table is parallel with outfeed table.
10. Tighten set screws in eccentric bushings on infeed table.
11. Set outfeed table height (refer to **Setting Outfeed Table Height** on Page 49).
12. Check/adjust infeed table stop (refer to **Calibrating Infeed Table Stop** on Page 50).

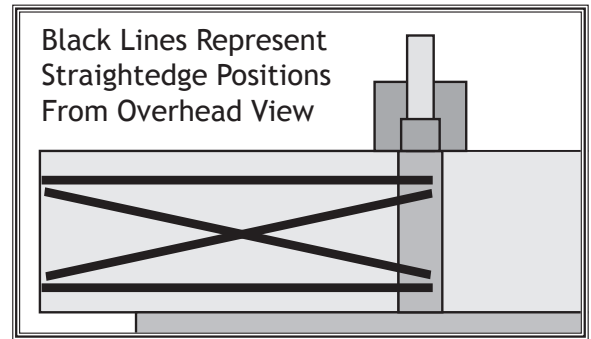

Figure 45. Straightedge positions for verifying if the outfeed table is parallel with cutterhead.

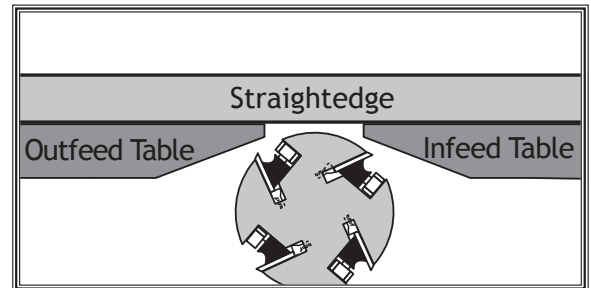

Figure 46. Infeed and outfeed tables set evenly (knife-style cutterhead shown).

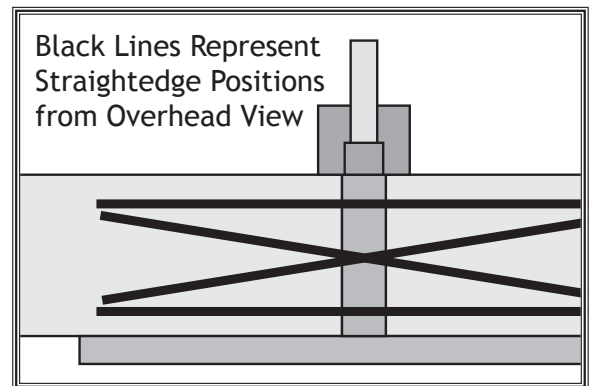

Figure 47. Straightedge positions for checking infeed/outfeed table parallelism.

Setting Outfeed Table Height

To help ensure safe operation and best cutting results, set the outfeed table height level with the knives/inserts when they are at top-dead-center (TDC). If the outfeed table is set too low, the workpiece will be tapered from front to back or there will be snipe (a gouge in end of board that is uneven with rest of cut). If the outfeed table is set too high, the workpiece will hit the edge of the outfeed table during operation, increasing the chance of kickback.

Item(s) Needed	Qty
Precision Straightedge 4'.....	1
Open-End Wrench 16mm.....	1

To set outfeed table height, do these steps:

1. DISCONNECT MACHINE FROM POWER!
2. Remove cutterhead guard, fence, and rear access panel on stand.
3. **W1859 Only:** Make sure knife heights are set correctly (refer to **Setting/Replacing Knives** on **Page 42**).
4. Loosen outfeed table lock located at front of machine, and loosen jam nuts and positive stop bolts located at side of machine just below outfeed table (see **Figure 48**).
5. Place straightedge on outfeed table so it extends over cutterhead.
6. Use motor pulley to rotate cutterhead until one knife or insert is at TDC (its highest point during rotation), as shown in **Figure 49**.
7. Use outfeed table lever to set outfeed table so knife or insert barely touches straightedge, as shown in **Figure 50**.
8. Tighten outfeed table lock located so outfeed table will not move during operation.
9. Re-install cutterhead guard, fence, and rear access panel on stand.
10. Verify proper operation of cutterhead guard (refer to **Checking/Adjusting Cutterhead Guard** on **Page 57**).

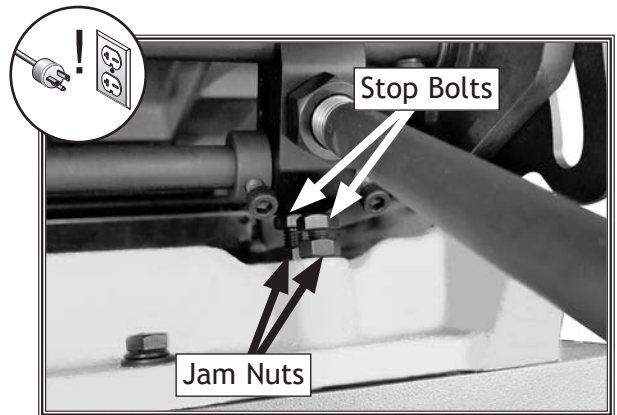

Figure 48. Location of outfeed table stop bolts and jam nuts.

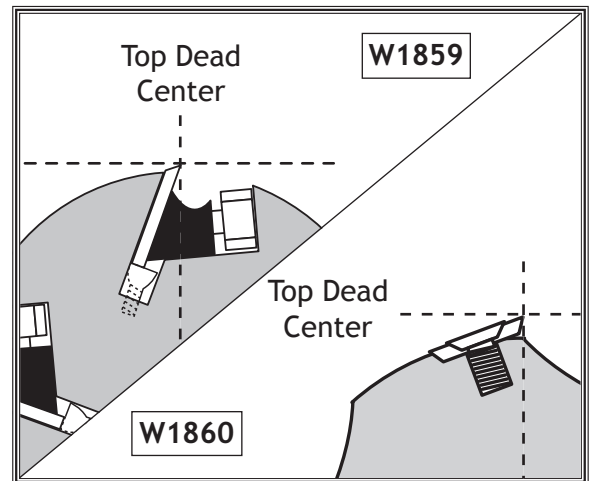

Figure 49. Knife or insert at TDC.

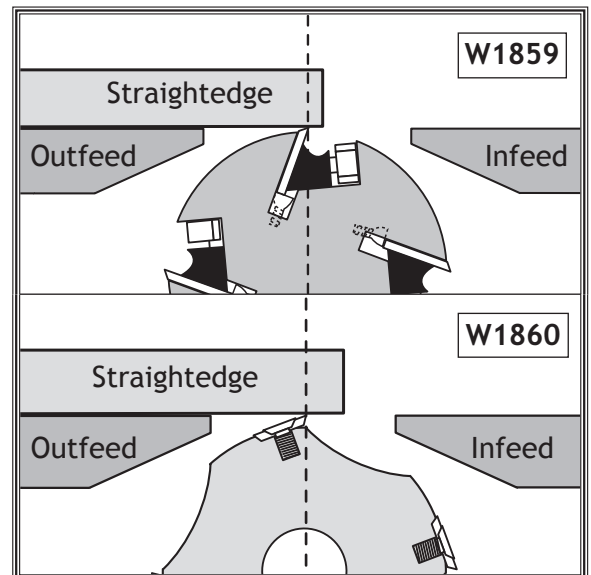

Figure 50. Using straightedge to check outfeed table height.

SERVICE

Calibrating 1/8" Infeed Table Stop

The infeed table on the Model W1859/W1860 has a built-in table stop that automatically sets maximum depth of cut at 1/8". It is necessary to adjust this stop if you adjust table parallelism.

Item(s) Needed	Qty
Precision Straightedge 3'.....	1
Tape Measure	1
Hex Wrench 5mm	1

To calibrate the 1/8" infeed table stop, do these steps:

1. DISCONNECT MACHINE FROM POWER!
2. Remove table release knob by unthreading it (see **Figure 51**), and then remove infeed table covers (see **Figure 51**) by removing plugs and cap screws that secure covers to table.
3. Loosen jam nut on the 1/8" infeed table stop bolt (see **Figure 52**), and then rotate stop bolt clockwise a couple turns to move it down, so it will clear the stop plate during adjustment process in later steps.
4. Place straightedge along outfeed table and position it so the end is just over infeed table, then lower infeed table until gap between infeed table and straightedge measures 1/8".

Tip: It may be easier to have another person help by holding the straightedge in position while you adjust table and measure gap.

5. Rotate stop bolt (see **Figure 52**) counterclockwise to move it upward until it makes firm contact with stop plate (see **Figure 52**).
6. Hold stop bolt in place, and tighten jam nut (see **Figure 52**) down firmly against the casting to secure stop bolt in place.
7. Replace table covers and re-install release knob.
8. Calibrate depth-of-cut scale (refer to **Calibrating Depth-of-Cut Scale on Page 54**).

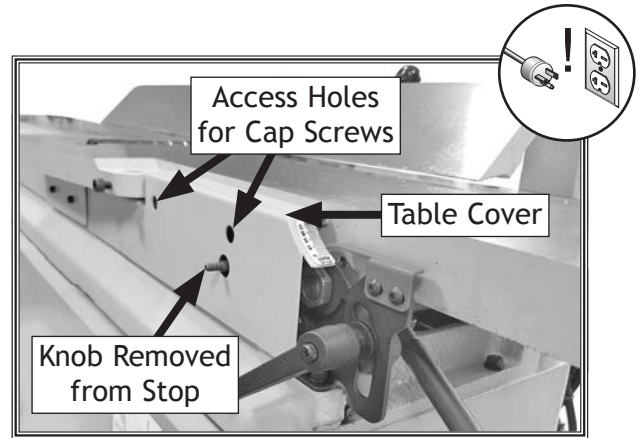

Figure 51. Accessing infeed table stop.

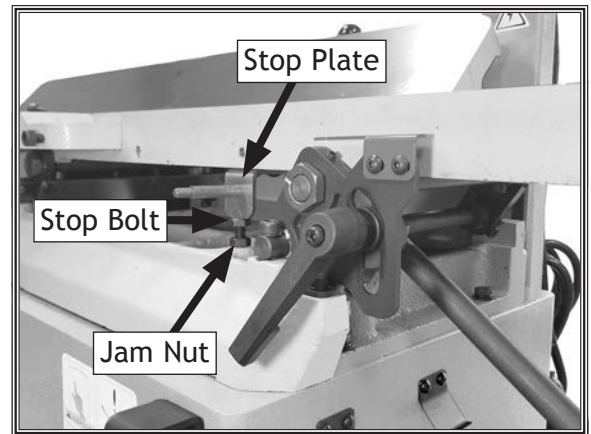

Figure 52. Location of 1/8" infeed table stop bolt and jam nut.

Setting Fence Stops

The fence stops simplify the task of adjusting the fence to 45° inward, 90°, and 45° outward (135°).

Item(s) Needed	Qty
Open-End Wrench 14mm.....	1
Sliding Bevel	1

Setting 45° Inward Stop

1. DISCONNECT MACHINE FROM POWER!
2. Loosen fence tilt lock, rotate stop block up, then tilt fence approximately 45° inward onto stop bolt (see **Figure 53**).
3. Place sliding bevel set to 45° against fence and table, as shown in **Figure 54**.
4. Loosen jam nut on 45° stop bolt and adjust stop bolt until fence is exactly 45° inward while resting on stop bolt (see **Figure 53**). Verify angle, then retighten jam nut.

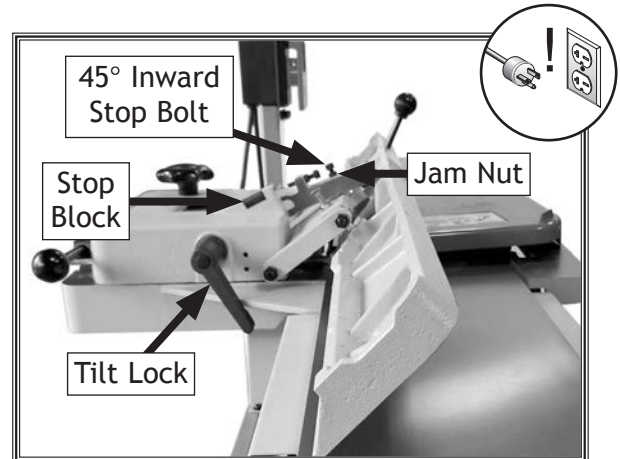

Figure 53. Fence set to 45° inward.

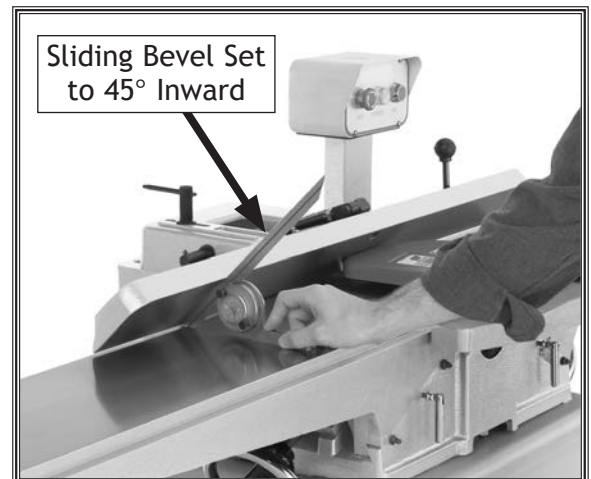

Figure 54. Example of adjusting fence to 45° inward.

Setting 90° Stop

1. DISCONNECT MACHINE FROM POWER!
2. Loosen fence tilt lock, rotate stop block down, and position fence approximately 90° onto stop cap screw (see Figure 55).

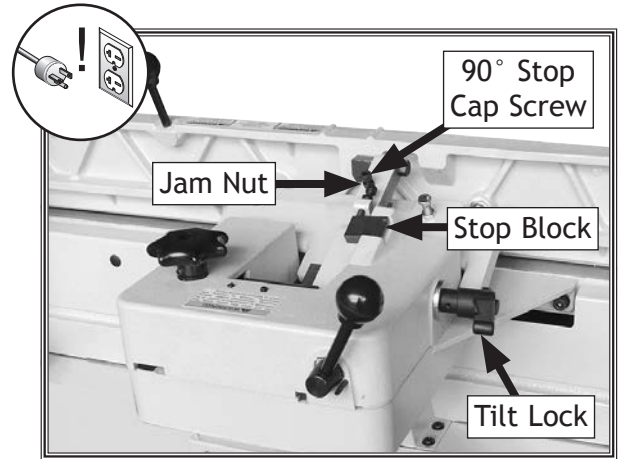

Figure 55. Fence set to 90°.

3. Place sliding bevel set to 90° against fence and table, as shown in Figure 56.
4. Loosen jam nut on 90° stop cap screw and adjust cap screw until fence is exactly 90° while cap screw is resting on stop block (see Figure 55). Verify angle, then retighten jam nut.

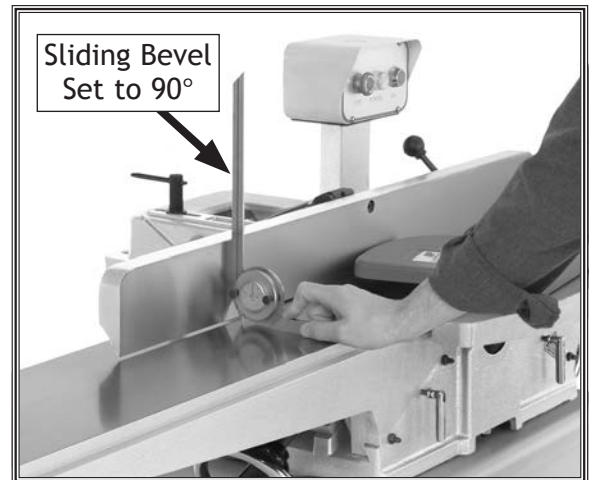

Figure 56. Example of adjusting fence to 90°.

Setting 45° Outward (135°) Stop

1. DISCONNECT MACHINE FROM POWER!
2. Loosen fence tilt lock, rotate stop block up, then tilt fence approximately 45° inward onto stop bolt (see **Figure 57**).

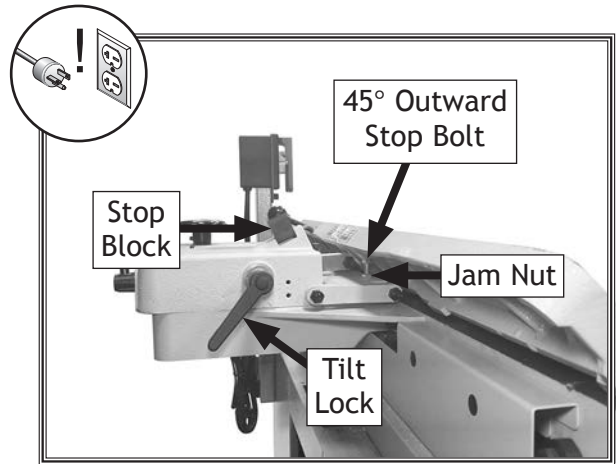

Figure 57. Fence set to 45° outward.

3. Place sliding bevel set to 135° against fence and table, as shown in **Figure 58**.
4. Loosen jam nut on 45° stop bolt and adjust stop bolt until fence is exactly 45° outward while resting on stop bolt (see **Figure 57**). Verify angle, then retighten jam nut.

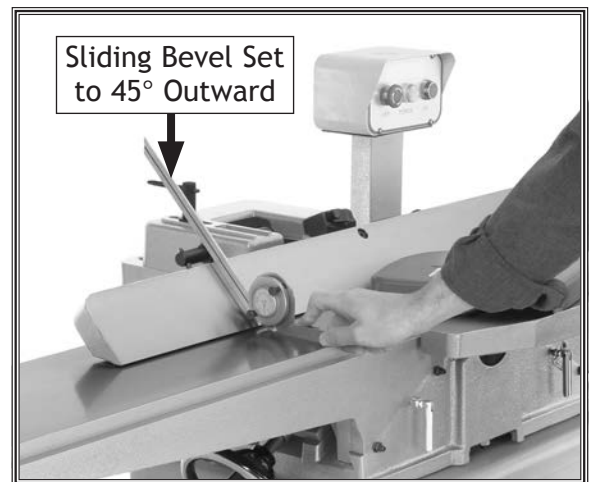

Figure 58. Example of adjusting fence to 45° outward.

Calibrating Depth-of-Cut Scale

For best cutting results, calibrate or "zero" the depth-of-cut scale so cutting depth shown on the scale matches the actual cutting depth (per pass).

Item(s) Needed	Qty
Precision Straightedge 4'.....	1
Hex Wrench 3mm	1

To calibrate the depth-of-cut scale, do these steps:

1. DISCONNECT MACHINE FROM POWER!
2. Make sure outfeed table height is set correctly (refer to **Setting Outfeed Table Height** on Page 49).
3. Place a straightedge across infeed and outfeed tables.
4. Adjust the infeed table until it is even with the outfeed table (see **Figure 59**).
5. Loosen button head screws that secure scale pointer, adjust scale pointer to "0," then re-tighten screws (see **Figure 60**).

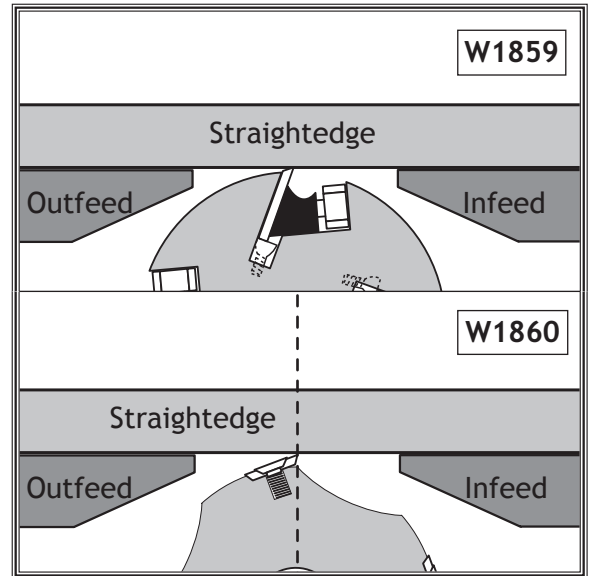

Figure 59. Infeed table even with outfeed table.

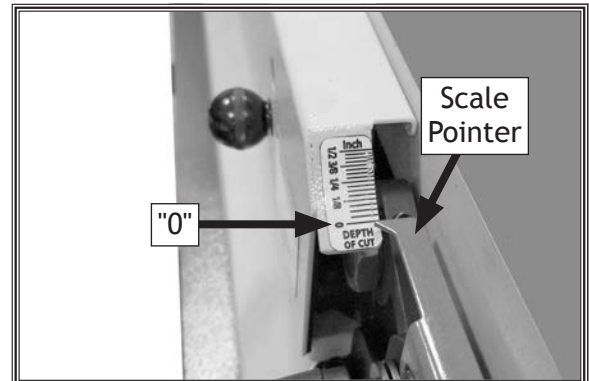

Figure 60. Depth-of-cut scale set to "0".

Tensioning/Replacing Belt

To ensure optimum power transmission from the motor to the cutterhead, the belt must be in good condition (free from cracks, fraying and wear) and properly tensioned.

Item(s) Needed	Qty
Replacement Belt (X1859136)	1
Phillips Screwdriver #2	1
Open-End or Socket Wrench 13mm	1

Tensioning Belt

1. DISCONNECT MACHINE FROM POWER!
2. Remove rear access panel on stand.
3. Loosen motor mount fasteners shown in **Figure 61**. DO NOT completely remove motor mount fasteners.
4. Press down on motor to keep tension on belt, and then tighten motor mount bracket fasteners (see **Figure 61**),
5. Press belt with moderate pressure in center to check belt tension. Belt is correctly tensioned when there is approximately 1/4" deflection when pushed, as shown in **Figure 62**.
 - If there is more than 1/4" deflection when you check belt tension, repeat the tensioning procedure until it is correct.
6. Replace rear access panel.

Replacing Belt

1. DISCONNECT MACHINE FROM POWER!
2. Remove fence, belt cover and rear access panel on stand.
3. Loosen motor mount bracket fasteners shown in **Figure 61**.
4. Use a 2x4 as leverage to lift motor as you remove belt and replace it with a new one. Make sure belt is seated in pulley groove.
5. Follow **Steps 4-5** in **Tensioning Belt** procedure to set correct belt tension.
6. Replace rear access panel.

⚠ CAUTION

Belts and pulleys will be hot after operation. Allow them to cool before handling.

NOTICE

After approximately 16 hours of operation, belts will stretch and seat into pulley grooves. The belts need to be re-tensioned after this initial break-in period to ensure optimum power transfer and maximum overall life of the belts.

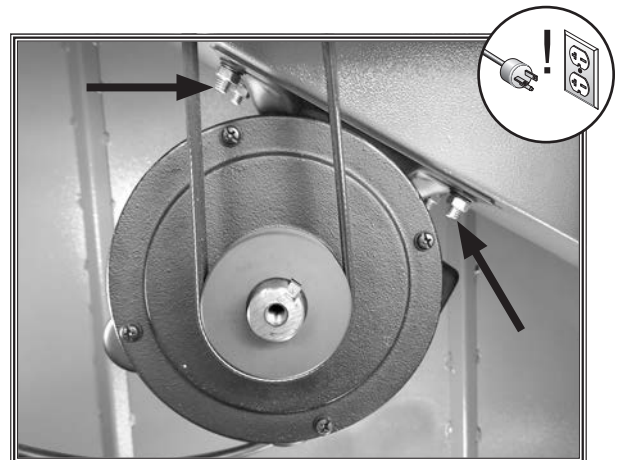

Figure 61. Location of motor mount fasteners (3 of 4 shown).

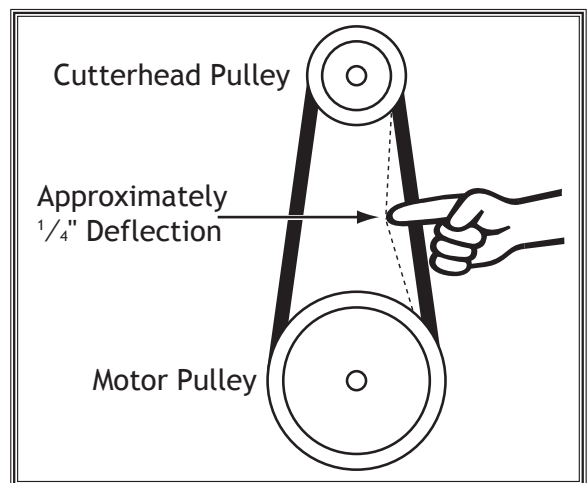

Figure 62. Checking belt deflection.

Checking/Aligning Pulleys

Pulley alignment is an important factor in power transmission and belt life. The pulleys should be parallel to each other and in the same plane (coplaner) for optimum performance.

Each pulley can be adjusted by loosening the set screw that secures the pulley to the shaft, sliding the pulley in/out, and retightening the set screw to lock the pulley in place.

Item(s) Needed	Qty
Precision Straightedge (Optional)	1
Hex Wrench 3mm	1
Phillips Head Screwdriver #2.....	1

To check/align pulleys, do these steps:

1. DISCONNECT MACHINE FROM POWER!
2. Remove fence, belt cover, and rear access panel on stand.
3. Look down length of belt and pulley faces to check pulley alignment (see **Figures 63-64**). If available use a narrow straightedge against pulley faces to check alignment.
 - If pulleys are aligned, proceed to **Step 7**.
 - If pulleys are not aligned, perform **Steps 4-6**.
4. Remove belt (refer to **Tensioning/Replacing Belt of Page 55**).
5. Loosen motor pulley set screw and cutterhead pulley set screw, and then align both pulleys. (Use straightedge if needed.)
6. Tighten set screws, replace belt, and repeat **Step 3** to verify proper pulley alignment. Pulleys should be aligned, as shown in **Figure 64**, when belt is properly tensioned.
7. Re-install fence, belt cover, and rear access panel on stand.

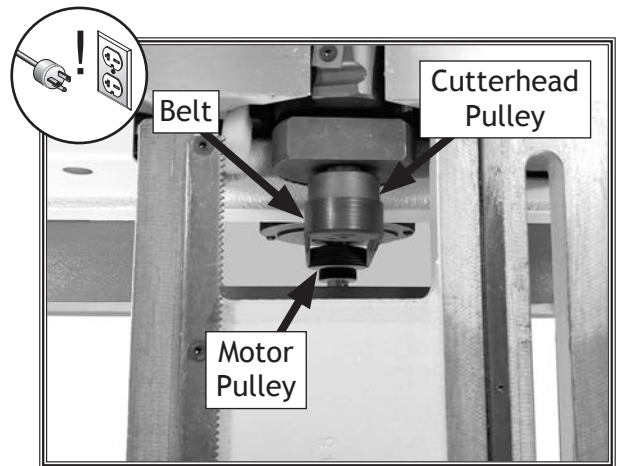

Figure 63. Checking pulley alignment (viewed from above).

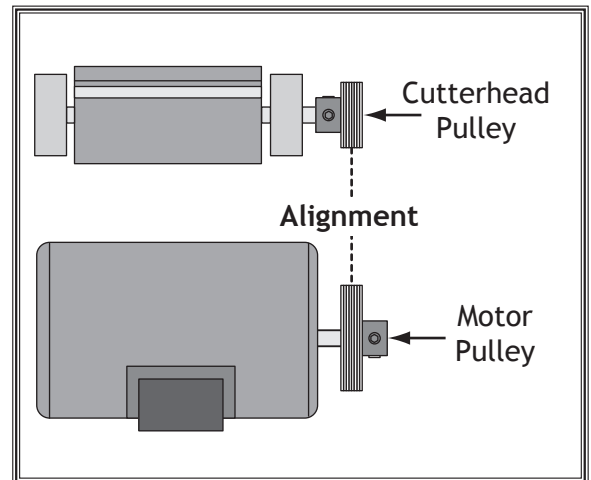

Figure 64. Proper pulley alignment.

Checking/Adjusting Cutterhead Guard

The cutterhead guard is designed to reduce the risk of accidental contact with hands or fingers with the spinning cutterhead. When properly installed and functioning correctly, the guard automatically rotates clear of the cutterhead during the cutting operation and then springs back over the cutterhead as soon as the operation is complete.

In order to function as intended, the guard must be installed as low as possible over the infeed table without actually touching it (approximately $\frac{1}{16}$ " above infeed table), and it must have enough spring tension at the mounting shaft to quickly reposition itself against the fence after it is rotated away from the cutterhead and released. Before performing rabbeting operation, adjust guard height to just clear outfeed table.

To check/adjust cutterhead guard for proper operation, do these steps:

1. DISCONNECT MACHINE FROM POWER!
2. Set fence to 90° and move it all the way back, then pull cutterhead guard (see **Figure 65**) back and let it go.
 - If cutterhead guard *springs* back over cutterhead, *contacts* fence, and *does not* drag across infeed table, then it is properly adjusted.
 - If cutterhead guard *does not* spring back over cutterhead, *does not* contact fence, or *drags* across infeed table, then proceed to **Step 3**.
3. Loosen shaft lock (see **Figure 65**). Move guard so it is resting against fence, and $\frac{1}{16}$ " above infeed table.
4. Holding guard height in place, tighten shaft lock to secure setting.
5. Repeat **Step 2** and, if necessary, repeat **Steps 3-4** until cutterhead guard is properly adjusted.

⚠ WARNING

The cutterhead guard is a critical safety feature of this jointer. You **MUST** install and verify its operation before using the jointer! Failure to properly install this guard will greatly increase the risk of serious personal injury.

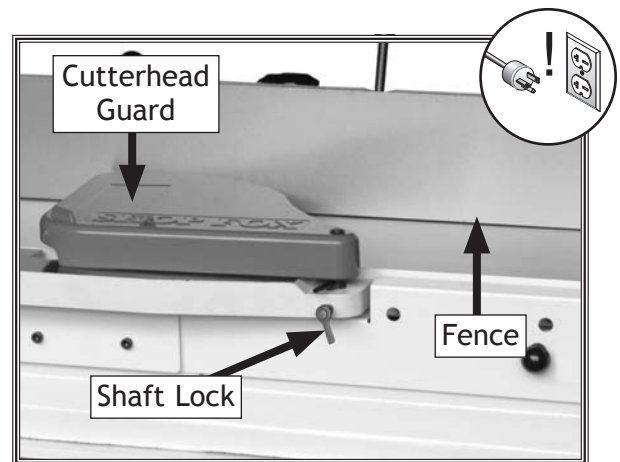
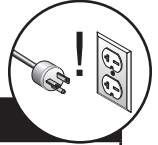

Figure 65. Cutterhead guard components.

Troubleshooting

The following troubleshooting tables cover common problems that may occur with this machine. If you need replacement parts or additional troubleshooting help, contact our Technical Support.

Note: Before contacting Tech Support, find the machine serial number and manufacture date, and if available, your original purchase receipt. This information is required to properly assist you.



Motor & Electrical

PROBLEM	POSSIBLE CAUSE	CORRECTIVE ACTION
Machine does not start or a breaker trips immediately after startup.	<ol style="list-style-type: none"> 1. Incorrect power supply voltage/circuit size. 2. Power supply circuit breaker tripped/fuse blown. 3. Motor wires connected incorrectly. 4. Wiring open/has high resistance. 5. ON/STOP switch at fault. 6. Start capacitor at fault. 7. Centrifugal switch at fault. 8. Motor at fault. 	<ol style="list-style-type: none"> 1. Ensure correct power supply voltage/circuit size. 2. Ensure circuit is sized correctly and free of shorts. Reset circuit breaker or replace fuse. 3. Correct motor wiring connections (Page 61). 4. Check/fix broken, disconnected, or corroded wires. 5. Test/replace switch. 6. Test/replace capacitor. 7. Adjust/replace centrifugal switch if available. 8. Test/repair/replace.
Machine stalls or is underpowered.	<ol style="list-style-type: none"> 1. Workpiece material not suitable. 2. Excessive feed rate. 3. Excessive depth of cut. 4. Dull knives/inserts. 5. Belt slipping or pulleys misaligned. 6. Dust collection blockage. 7. Motor overheated. 8. Pulley slipping on shaft. 9. Run capacitor at fault. 10. Centrifugal switch at fault. 11. Motor bearings at fault. 12. Motor at fault. 	<ol style="list-style-type: none"> 1. Ensure workpiece is suitable for jointing (Page 26). 2. Reduce feed rate. 3. Reduce depth of cut (Page 33). 4. Sharpen/replace knives (Page 42); rotate/replace inserts (Page 43). 5. Tension/replace belt (Page 55); ensure pulleys are aligned (Page 56). 6. Clear blockages, seal leaks, use smooth-wall duct, eliminate bends, close other branches. 7. Clean motor, let cool, and reduce workload. 8. Tighten/replace loose pulley/shaft, replace shaft key; tighten pulley set screw. 9. Test/repair/replace. 10. Adjust/replace centrifugal switch if available. 11. Test/repair/replace. 12. Test/repair/replace.
Machine has vibration or noisy operation.	<ol style="list-style-type: none"> 1. Mobile base lock knobs loose or stand feet not adjusted properly. 2. Motor or other component loose. 3. Belt worn or loose. 4. Motor fan rubbing on fan cover. 5. Pulley loose or misaligned. 6. Dull knives/inserts. 7. Cutterhead bearings at fault. 8. Centrifugal switch at fault. 9. Motor bearings at fault. 	<ol style="list-style-type: none"> 1. Tighten mobile base lock knobs or adjust stand feet to stabilize machine. 2. Replace missing bolts/nuts, or tighten if loose. 3. Inspect/tension or replace belt (Page 55). 4. Fix/replace fan cover; replace loose/damaged fan. 5. Secure pulley on shaft or realign (Page 56). 6. Sharpen/replace knives (Page 42); rotate/replace inserts (Page 43). 7. Replace bearing(s). 8. Adjust/replace centrifugal switch if available. 9. Test/repair/replace.

Machine Operation

PROBLEM	POSSIBLE CAUSE	CORRECTIVE ACTION
Table is hard to adjust.	<ol style="list-style-type: none"> 1. Table lock engaged/partially engaged. 2. Table stop blocking movement. 	<ol style="list-style-type: none"> 1. Completely loosen table lock (Page 9). 2. Loosen/reset table stop (Page 34).
Excessive snipe (gouge in end of board that is uneven with rest of cut).	<ol style="list-style-type: none"> 1. Outfeed table set too low. 2. Knives set too high (W1859). 3. Operator pushing down on trailing end of workpiece as it leaves cutterhead. 	<ol style="list-style-type: none"> 1. Align outfeed table with cutterhead knife/insert at top dead center (Page 49). 2. Adjust height of knives evenly with outfeed table (Page 42). 3. Reduce/eliminate downward pressure on trailing end of workpiece as it leaves cutterhead.
Workpiece stops in middle of cut.	<ol style="list-style-type: none"> 1. Outfeed table set too high. 	<ol style="list-style-type: none"> 1. Align outfeed table with cutterhead knife/insert at top dead center (Page 49).
Workpiece chipping, tear-out, indentations, or overall rough cuts.	<ol style="list-style-type: none"> 1. Workpiece not suitable for jointing. 2. Operator not feeding workpiece to cut "with" the grain. 3. Feed rate too fast. 4. Excessive depth of cut. 5. Dull knives/inserts. 6. Dust collection problems. 	<ol style="list-style-type: none"> 1. Ensure workpiece is suitable for jointing (Page 26). 2. Turn workpiece 180° before feeding again. 3. Reduce feed rate. 4. Reduce depth of cut (Page 33). 5. Sharpen/replace knives (Page 42); rotate/replace inserts (Page 43). 6. Clear blockages, seal leaks, move machine closer to dust collector, upgrade dust collector.
Fuzzy grain left in workpiece.	<ol style="list-style-type: none"> 1. Wood has high moisture content. 2. Dull knives/inserts. 	<ol style="list-style-type: none"> 1. Ensure wood moisture content is less than 20%. Allow to dry if necessary. 2. Sharpen/replace knives (Page 42); rotate/replace inserts (Page 43).
Long lines or ridges that run along length of workpiece.	<ol style="list-style-type: none"> 1. Nicked or chipped knives/inserts. 2. Inserts not consistently tightened/torqued (W1860). 3. Dirt or debris under inserts (W1860). 	<ol style="list-style-type: none"> 1. Replace knives (Page 42); rotate/replace inserts (Page 43). 2. Tighten/torque all inserts consistently when rotating/replacing (Page 43). 3. Remove inserts, properly clean mounting pocket and re-install (Page 43).
Uneven cutter marks, wavy surface, or chatter marks across face of workpiece.	<ol style="list-style-type: none"> 1. Feeding workpiece too fast. 2. Knives not properly adjusted (W1859). 3. Dirt or debris under inserts (W1860). 	<ol style="list-style-type: none"> 1. Reduce feed rate. 2. Properly adjust knives (Page 42). 3. Remove inserts, properly clean mounting pocket, and re-install (Page 43).
Glossy surface; scorching or burn marks on workpiece.	<ol style="list-style-type: none"> 1. Feed rate too slow. 2. Dull knives/inserts. 	<ol style="list-style-type: none"> 1. Increase feed rate. 2. Sharpen/replace knives (Page 42); rotate/replace inserts (Page 43).
Workpiece is concave or convex along its length after jointing.	<ol style="list-style-type: none"> 1. Workpiece not held with even pressure against outfeed table during cut. 2. Workpiece excessively bowed or warped, not suitable for jointing. 3. Tables are not parallel with cutterhead and each other. 	<ol style="list-style-type: none"> 1. Apply even downward pressure against workpiece throughout entire travel along outfeed side during cut. 2. Ensure workpiece is suitable for jointing (Page 26). 3. Check/adjust table parallelism (Page 45).
Workpiece edges not square; tapered cut produced.	<ol style="list-style-type: none"> 1. Fence not square to table(s); fence tilt unlocked. 2. Knives not properly adjusted (W1859). 3. Inserts not consistently tightened/torqued (W1860). 4. Warped infeed or outfeed table. 	<ol style="list-style-type: none"> 1. Square fence to table(s) (Page 51); lock fence. 2. Properly adjust knives (Page 42). 3. Tighten/torque all inserts consistently when rotating/replacing (Page 43). 4. Regrind/replace table.

Electrical Safety Instructions

These pages are current at the time of printing. However, in the spirit of improvement, we may make changes to the electrical systems of future machines. Compare the manufacture date of your machine to the one stated in this manual, and study this section carefully.

If there are differences between your machine and what is shown in this section, call Technical Support at (360) 734-3482 for assistance BEFORE making any changes to the wiring on your machine. An updated wiring diagram may be available. **Note:** Please gather the serial number and manufacture date of your machine before calling. This information can be found on the main machine label.

⚠ WARNING

SHOCK HAZARD. Working on wiring that is connected to a power source is extremely dangerous. Touching electrified parts will result in personal injury including but not limited to severe burns, electrocution, or death. Disconnect the power from the machine before servicing electrical components!

QUALIFIED ELECTRICIAN. Due to the inherent hazards of electricity, only a qualified electrician should perform wiring tasks on this machine. If you are not a qualified electrician, get help from one before attempting any kind of wiring job.

WIRE CONNECTIONS. All connections must be tight to prevent wires from loosening during machine operation. Double-check all wires disconnected or connected during any wiring task to ensure tight connections.

WIRE/COMPONENT DAMAGE. Damaged wires or components increase the risk of serious personal injury, fire, or machine damage. If you notice that any wires or components are damaged while performing a wiring task, replace those wires or components before completing the task.

MODIFICATIONS. Using aftermarket parts or modifying the wiring beyond what is shown in the diagram may lead to unpredictable results, including serious injury or fire.

MOTOR WIRING. The motor wiring shown in these diagrams is current at the time of printing, but it may not match your machine. Always use the wiring diagram inside the motor junction box.

CAPACITORS/INVERTERS. Some capacitors and power inverters store an electrical charge for up to 10 minutes after being disconnected from the power source. To reduce the risk of being shocked, wait at least this long before working on capacitors.

CIRCUIT REQUIREMENTS. You MUST follow the requirements at the beginning of this manual when connecting your machine to a power source.

EXPERIENCING DIFFICULTIES. If you are experiencing difficulties understanding the information included in this section, contact our Technical Support at (360) 734-3482.

NOTICE

The photos and diagrams included in this section are best viewed in color. You can view these pages in color at www.shopfox.biz.

WIRING DIAGRAM COLOR KEY

BLACK — Bk	BLUE — Bl	YELLOW — Yl	LIGHT BLUE — Lb
WHITE — Wt	BROWN — Br	YELLOW GREEN — Yg	BLUE WHITE — Bw
GREEN — Gn	GRAY — Gy	PURPLE — Pu	TUR-QUOISE — Tu
RED — Rd	ORANGE — Or	PINK — Pk	

Wiring Diagram

Paddle Switch
(viewed from behind)



WARNING!
SHOCK HAZARD!
Disconnect power
before working on
wiring

NOTICE

The motor wiring shown here is current at the time of printing, but it may not match your machine. Always use the wiring diagram inside the motor junction box.

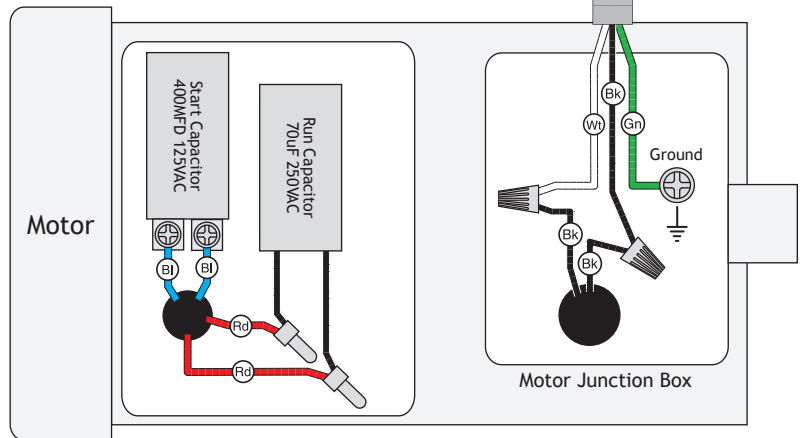
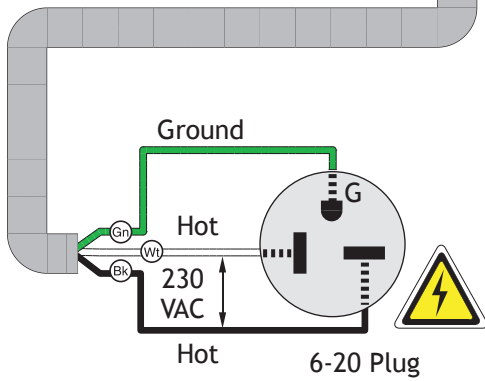
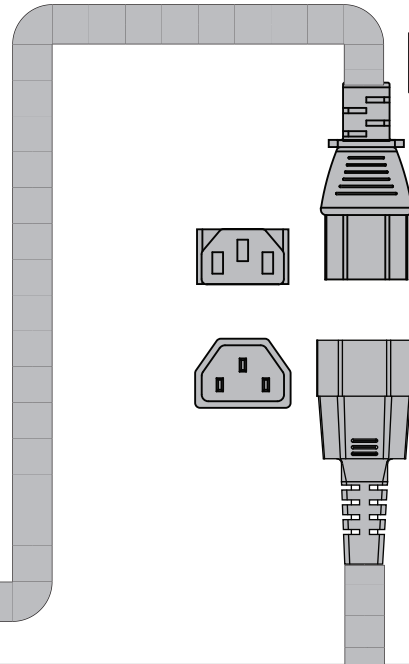
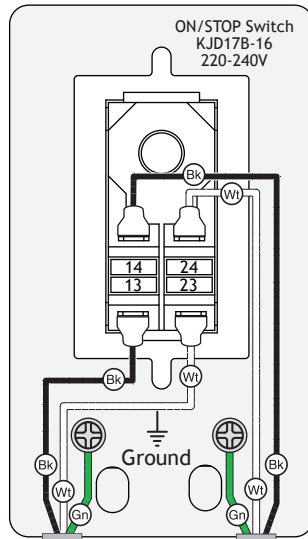

Figure 66. On/Off switch connections.

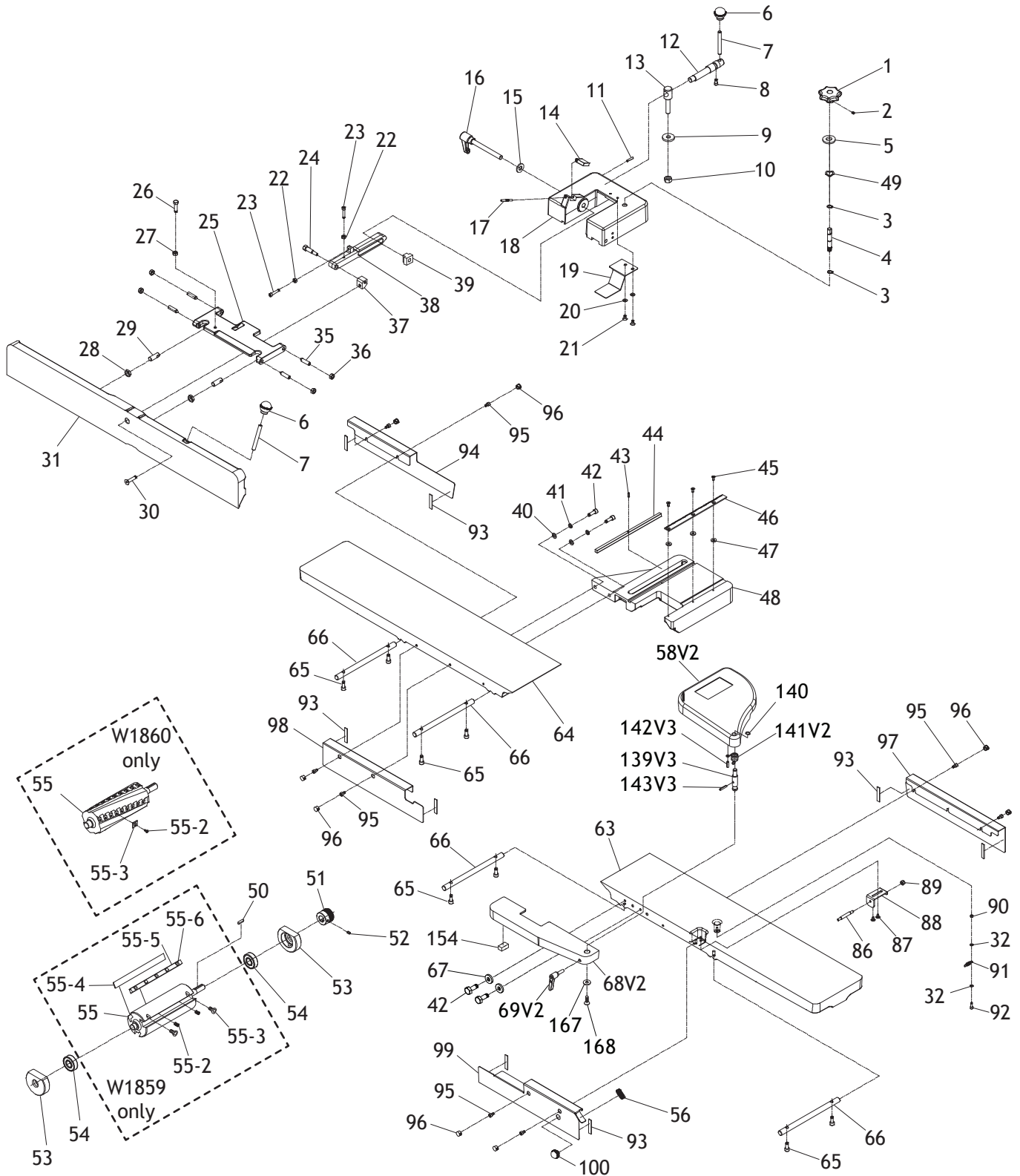

Figure 67. Motor junction box connections.

SERVICE

PARTS

Tables, Fence & Cutterhead



PARTS



Tables, Fence & Cutterhead Parts List

REI	PART #	DESCRIPTION
1	X1859001	KNOB 12ID, M6-1 SET SCREW THREADS
2	X1859002	SET SCREW M6-1 X 6
3	X1859003	EXT RETAINING RING 12MM
4	X1859004	GEAR SHAFT 10T, 11 X 78.5MM
5	X1859005	FLAT WASHER 12MM
6	X1859006	BALL KNOB 3/8-16, D1-5/16
7	X1859007	STUD-DE 3/8-16 X 3-1/8, 3/8
8	X1859008	CAP SCREW 1/4-20 X 1/2
9	X1859009	FENDER WASHER 1/2
10	X1859010	LOCK NUT 1/2-12
11	X1859011	ROLL PIN 4 X 25
12	X1859012	ECCENTRIC SHAFT 3/8-16, 5-1/4L
13	X1859013	CAMLOCK STUD 1/2-12 X1-3/16, 3-1/2L
14	X1859014	STOP BLOCK
15	X1859015	FLAT WASHER 1/2
16	X1859016	ADJ HANDLE 3L, 1/2-12 X 1-3/8
17	X1859017	DOWEL PIN 5 X 50
18	X1859018	FENCE CARRIAGE
19	X1859019	SAFETY PLATE
20	X1859020	FLAT WASHER 1/4
21	X1859021	FLAT HD SCR 1/4-20 X 1/2
22	X1859022	HEX NUT 1/4-20
23	X1859023	CAP SCREW 1/4-20 X 1-1/4
24	X1859024	SHOULDER BOLT 5/16-18 X 11/16, 3/8 X 1
25	X1859025	FENCE SWIVEL BASE
26	X1859026	HEX BOLT 5/16-18 X 1-1/4
27	X1859027	HEX NUT 5/16-18
28	X1859028	HEX NUT 1/2-20 THIN
29	X1859029	STUD-SE 1/2-20 X 1-3/8, 11/16
30	X1859030	FLAT HD CAP SCR 5/16-18 X 1-1/2
31	X1859031	FENCE
32	X1859032	FLAT WASHER 5MM
35	X1859035	SET SCREW 3/8-16 X 1-1/2 CONE-PT
36	X1859036	HEX NUT 3/8-16 THIN
37	X1859037	FENCE BLOCK
38	X1859038	FENCE LINK
39	X1859039	T-NUT 1/2-12
40	X1859040	FLAT WASHER 8MM
41	X1859041	LOCK WASHER 8MM
42	X1859042	CAP SCREW M8-1.25 X 25
43	X1859043	ROLL PIN 4 X 20
44	X1859044	KEY 9.5 X 9.5 X 268
45	X1859045	FLAT HD CAP SCR M5-.8 X 12
46	X1859046	FENCE GUIDE
47	X1859047	FLAT WASHER 1/4
48	X1859048	FENCE BASE
49	X1859049	WAVY WASHER 19MM

REF	PART #	DESCRIPTION
50	X1859050	KEY 5 X 5 X 22
51	X1859051	CUTTERHEAD PULLEY
52	X1859052	SET SCREW M6-1 X 8
53	X1859053	BEARING BLOCK
54	X1859054	BALL BEARING 6204-2NSE
55	X1859055	CUTTERHEAD 8" 4-KNIFE (W1859)
55-2	X1859055-2	COMPRESSION SPRING (W1859)
55-3	X1859055-3	FLAT HD CAP SCR M5-.8 X 12 (W1859)
55-4	X1859055-4	KNIFE 8 X 3/4 X 1/8 HSS (W1859)
55-5	X1859055-5	KNIFE GIB (W1859)
55-6	X1859055-6	KNIFE GIB BOLT 1/4-28 X 1/4 (W1859)
55	X1860055	HELICAL CUTTERHEAD 8" (W1860)
55-2	X1860055-2	FLAT HD TORX SCR T-25 10-24 X 1/2 (W1860)
55-3	X1860055-3	CARBIDE INSERT 15 X 15 X 2.5MM (W1860)
56	X1859056	DEPTH SCALE LABEL
58V2	X1859058V2	CUTTERHEAD GUARD V2.08.19
63	X1859063	INFEED TABLE
64	X1859064	OUTFEED TABLE
65	X1859065	CAP SCREW M8-1.25 X 25
66	X1859066	TABLE SHAFT 9-5/8L
67	X1859067	FLAT WASHER 8MM
68V2	X1859068V2	RABBETING TABLE V2.08.19
69V2	X1859069V2	GUARD LOCK HANDLE V2.07.19
86	X1859086	STANDOFF-RND MM 1/4-20 X 2-3/8, 1/2
87	X1859087	SHOULDER FLANGE SCR M5-.8, 6 X 3.3
88	X1859088	POSITION PLATE
89	X1859089	LOCK NUT 1/4-20
90	X1859090	HEX NUT M5-.8
91	X1859091	EXTENSION SPRING
92	X1859092	CAP SCREW M5-.8 X 15
93	X1859093	FOAM PAD
94	X1859094	REAR COVER (LEFT)
95	X1859095	CAP SCREW M6-1 X 10
96	X1859096	PLUG (PLASTIC)
97	X1859097	REAR COVER (RIGHT)
98	X1859098	FRONT COVER (LEFT)
99	X1859099	FRONT COVER (RIGHT)
100	X1859100	BALL KNOB 1/4-20, D1
139V3	X1859139V3	GUARD PIVOT SHAFT V3.07.19
140	X1859140	EXT RETAINING RING 11MM
141V2	X1859141V2	TORSION SPRING V2.07.19
142V3	X1859142V3	ROLL PIN 6 X 25 V3.07.19
143V3	X1859143V3	ROLL PIN 5 X 26 V3.07.19
154	X1859154	FOAM PAD 30 X 30 X 22
167	X1859167	FENDER WASHER 6.7 X 19 X 2MM
168	X1859168	BUTTON HD CAP SCR M6-1 X 12

Base, Stand & Motor

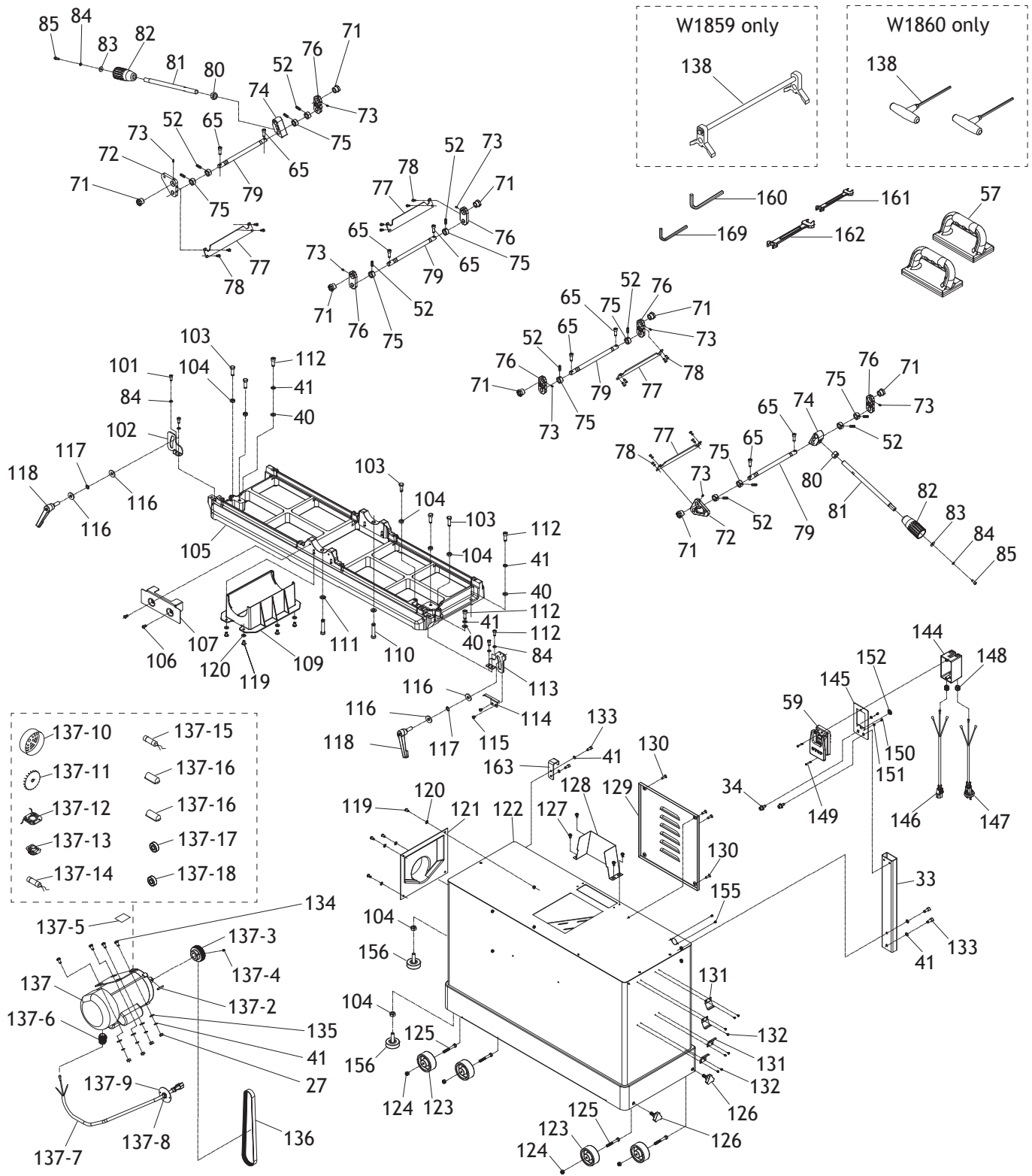



Base, Stand & Motor Parts List

REF PART #	DESCRIPTION
33	X1859033 SWITCH PEDESTAL
34	X1859034 CAP SCREW M8-1.25 X 20 W/WASHERS
40	X1859040 FLAT WASHER 8MM
41	X1859041 LOCK WASHER 8MM
57	X1859057 PUSH BLOCK
59	X1859059 ON/OFF BUTTON KEDU KJD17B-230V-S
71	X1859071 ECCENTRIC BUSHING
72	X1859072 BUSHING PLATE (3-HOLE)
73	X1859073 SET SCREW M5-.8 X 8
74	X1859074 ELEVATION BRACKET
75	X1859075 BUSHING
76	X1859076 BUSHING PLATE (2-HOLE)
77	X1859077 ELEVATION PLATE
78	X1859078 CAP SCREW M5-.8 X 10
79	X1859079 ELEVATION SHAFT 10-1/4L
80	X1859080 HEX NUT M16-2
81	X1859081 SHAFT INT THR M6-1, EXT THR M16-2
82	X1859082 LEVER KNOB
83	X1859083 FLAT WASHER 6MM
84	X1859084 LOCK WASHER 6MM
85	X1859085 CAP SCREW M6-1 X 16
101	X1859101 CAP SCREW M6-1 X 15
102	X1859102 OUTFEED TABLE LOCK PLATE
103	X1859103 HEX BOLT M8-1.25 X 30
104	X1859104 HEX NUT M8-1.25
105	X1859105 TABLE BASE
106	X1859106 FLAT HD CAP SCR M6-1 X 10
107	X1859107 CUTTERHEAD FRONT COVER
109	X1859109 DUST COVER
110	X1859110 CAP SCREW 3/8-24 X 2
111	X1859111 LOCK WASHER 3/8
112	X1859112 HEX BOLT M8-1.25 X 25
113	X1859113 INFEEED TABLE LOCK PLATE
114	X1859114 SCALE POINTER
115	X1859115 BUTTON HD CAP SCREW M5-.8 X 6
116	X1859116 FLAT WASHER 10MM
117	X1859117 WAVY WASHER 10MM
118	X1859118 ADJ HANDLE M10-1.5 X 25, 93L
119	X1859119 PHLP HD SCR M6-1 X 12
120	X1859120 FLAT WASHER 6MM
121	X1859121 DUST PORT 4"
122	X1859122 CABINET STAND
123	X1859123 WHEEL
124	X1859124 LOCK NUT M8-1.25
125	X1859125 WHEEL AXLE M8-1.25 X 30, 60L
126	X1859126 KNOB BOLT 3-LOBE, M10-1.5 X 22, D40

REF PART #	DESCRIPTION
127	X1859127 PHLP HD SCR M6-1 X 10 W/WASHER
128	X1859128 BELT COVER
129	X1859129 REAR ACCESS PANEL
130	X1859130 PHLP HD SCR M6-1 X 20
131	X1859131 PUSH BLOCK BRACKET
132	X1859132 PHLP HD SCR M4-.7 X 8
133	X1859133 CAP SCREW M8-1.25 X 20
134	X1859134 CARRIAGE BOLT 5/16-18 X 3/4
135	X1859135 FLAT WASHER 8MM
136	X1859136 POLY-V BELT 300J7
137	X1859137 MOTOR 3HP 230V 1-PH
137-2	X1859137-2 KEY 5 X 5 X 30
137-3	X1859137-3 MOTOR PULLEY
137-4	X1859137-4 SET SCREW M6-1 X 8
137-5	X1859137-5 MOTOR LABEL
137-6	X1859137-6 STRAIN RELIEF TYPE-3 PG13.5
137-7	X1859137-7 MOTOR CORD 14G 3W 32"
137-8	X1859137-8 STRAIN RELIEF TYPE-1 3/4"
137-9	X1859137-9 BACKING BOARD
137-10	X1859137-10 MOTOR FAN COVER
137-11	X1859137-11 MOTOR FAN
137-12	X1859137-12 CONTACT PLATE
137-13	X1859137-13 CENTRIFUGAL SWITCH
137-14	X1859137-14 S CAPACITOR 400M 125V 1-1/2 X 3-1/2
137-15	X1859137-15 R CAPACITOR 70M 250V 1-1/2 X 3-1/2
137-16	X1859137-16 CAPACITOR COVER
137-17	X1859137-17 BALL BEARING 6205ZZ (FRONT)
137-18	X1859137-18 BALL BEARING 6203ZZ (REAR)
138	X1859138 KNIFE-SETTING JIG (W1859)
138	X1860138 TORX DRIVER T-25 (W1860)
144	X1859144 SWITCH BOX
145	X1859145 SWITCH PLATE
146	X1859146 SWITCH CORD 14G 3W 20"
147	X1859147 POWER CORD 14G 3W 10' 6-20P
148	X1859148 STRAIN RELIEF TYPE-1 5/8"
149	X1859149 PHLP HD SCR M4-.7 X 25
150	X1859150 PHLP HD SCR M4-.7 X 6
151	X1859151 EXT TOOTH WASHER 4MM
152	X1859152 GROUND LABEL
155	X1859155 TAP SCREW M6 X 8
156	X1859156 ADJUSTABLE FOOT M8-1.25
160	X1859160 HEX WRENCH 6MM
161	X1859161 WRENCH 8 X 10MM OPEN-ENDS
162	X1859162 WRENCH 11 X 13MM OPEN-ENDS
163	X1859163 LIFTING HOOK
169	X1859169 HEX WRENCH 4MM

Labels & Cosmetics

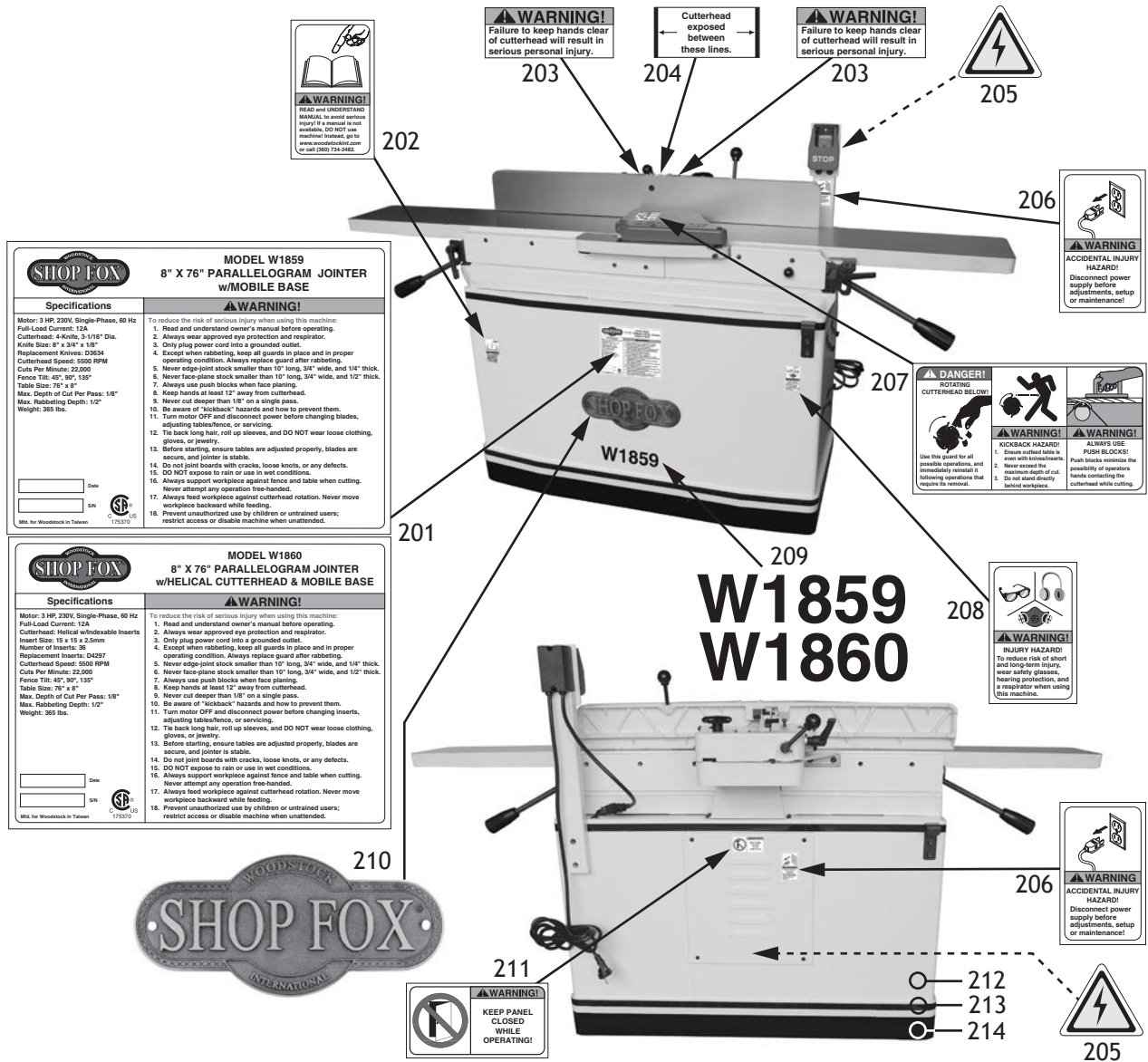

SHOP FOX	
MODEL W1859 8" X 76" PARALLELOGRAM JOINTER w/MOBILE BASE	
Specifications	
Motor: 3 HP, 230V, Single-Phase, 60 Hz Full-Load Current: 12A Cutterhead: 4-Blade, 3-1/8" Dia. Knife Size: 8" x 3/4" x 1/8" Replacement Knives: C2834 Cutterhead Speed: 5500 RPM Cuts Per Minute: 22,000 Fence Tilt: 45°, 90°, 135° Table Size: 70" x 8" Max. Depth of Cut Per Pass: 1/8" Max. Rabbeting Depth: 1/2" Weight: 365 lbs.	<p>To reduce the risk of serious injury when using this machine:</p> <ol style="list-style-type: none"> 1. Read and understand owner's manual before operating. 2. Always wear approved eye protection and respirator. 3. Only plug power cord into a grounded outlet. 4. Except when rabbeting, keep all guards in place and in proper operating condition. Always replace guard after rabbeting. 5. Never edge-joint stock smaller than 10" long, 3/4" wide, and 1/4" thick. 6. Never face-plane stock smaller than 10" long, 3/4" wide, and 1/2" thick. 7. Always use push blocks when face planing. 8. Keep hands at least 12" away from cutterhead. 9. Never cut deeper than 1/8" on a single pass. 10. Be aware of "kickback" hazards and how to prevent them. 11. Turn motor OFF and disconnect power before changing blades, adjusting table/fence, or servicing. 12. Tie back long hair, roll up sleeves, and DO NOT wear loose clothing, gloves, or jewelry. 13. Before starting, ensure tables are adjusted properly, blades are secure, and jointer is stable. 14. Do not joint boards with cracks, loose knots, or any defects. 15. DO NOT expose to rain or use in wet conditions. 16. Always support workpiece against fence and table when cutting. Never attempt any operation free-handed. 17. Always feed workpiece against cutterhead rotation. Never move workpiece backward while feeding. 18. Prevent unauthorized use by children or untrained users; restrict access or disable machine when unattended.

SHOP FOX	
MODEL W1860 8" X 76" PARALLELOGRAM JOINTER w/HELICAL CUTTERHEAD & MOBILE BASE	
Specifications	
Motor: 3 HP, 230V, Single-Phase, 60 Hz Full-Load Current: 12A Cutterhead: Helical, windable inserts Insert Size: 1.5 x 1.5 x 2.5mm Number of Inserts: 36 Replacement Inserts: D4287 Cutterhead Speed: 5500 RPM Cuts Per Minute: 22,000 Fence Tilt: 45°, 90°, 135° Table Size: 70" x 8" Max. Depth of Cut Per Pass: 1/8" Max. Rabbeting Depth: 1/2" Weight: 365 lbs.	<p>To reduce the risk of serious injury when using this machine:</p> <ol style="list-style-type: none"> 1. Read and understand owner's manual before operating. 2. Always wear approved eye protection and respirator. 3. Only plug power cord into a grounded outlet. 4. Except when rabbeting, keep all guards in place and in proper operating condition. Always replace guard after rabbeting. 5. Never edge-joint stock smaller than 10" long, 3/4" wide, and 1/4" thick. 6. Never face-plane stock smaller than 10" long, 3/4" wide, and 1/2" thick. 7. Always use push blocks when face planing. 8. Keep hands at least 12" away from cutterhead. 9. Never cut deeper than 1/8" on a single pass. 10. Be aware of "kickback" hazards and how to prevent them. 11. Turn motor OFF and disconnect power before changing inserts, adjusting table/fence, or servicing. 12. Tie back long hair, roll up sleeves, and DO NOT wear loose clothing, gloves, or jewelry. 13. Before starting, ensure tables are adjusted properly, blades are secure, and jointer is stable. 14. Do not joint boards with cracks, loose knots, or any defects. 15. DO NOT expose to rain or use in wet conditions. 16. Always support workpiece against fence and table when cutting. Never attempt any operation free-handed. 17. Always feed workpiece against cutterhead rotation. Never move workpiece backward while feeding. 18. Prevent unauthorized use by children or untrained users; restrict access or disable machine when unattended.

REF	PART #	DESCRIPTION
201	X1859201	MACHINE ID LABEL (W1859)
201	X1860201	MACHINE ID LABEL (W1860)
202	X1859202	READ MANUAL LABEL
203	X1859203	CUTTERHEAD WARNING LABEL
204	X1859204	CUTTERHEAD EXPOSED LABEL
205	X1859205	ELECTRICITY LABEL
206	X1859206	DISCONNECT POWER LABEL
207	X1859207	CUTTERHEAD GUARD LABEL

REF	PART #	DESCRIPTION
208	X1859208	EYES EARS LUNGS WARNING LABEL
209	X1859209	MODEL NUMBER LABEL (W1859)
209	X1860209	MODEL NUMBER LABEL (W1860)
210	X1859210	SHOPFOX NAMEPLATE-LARGE
211	X1859211	PANEL CLOSED WARNING LABEL
212	X1859212	TOUCH-UP PAINT, SHOP FOX WHITE
213	X1859213	BLACK TRIM TAPE
214	X1859214	TOUCH-UP PAINT, SHOP FOX BLACK

WARNING

Safety labels warn about machine hazards and how to prevent serious personal injury. The owner of this machine **MUST** maintain the original location and readability of all labels on this machine. If any label is removed or becomes unreadable, **REPLACE** that label before allowing machine to be operated again. Contact us at (360) 734-3482 or www.woodstockint.com to order new labels.

WARRANTY

Woodstock International, Inc. warrants all Shop Fox machinery to be free of defects from workmanship and materials for a period of two years from the date of original purchase by the original owner. This warranty does not apply to defects due directly or indirectly to misuse, abuse, negligence or accidents, lack of maintenance, or reimbursement of third party expenses incurred.

Woodstock International, Inc. will repair, replace, or arrange for a dealer refund, at its expense and option, the Shop Fox machine or machine part proven to be defective for its designed and intended use, provided that the original owner returns the product prepaid to an authorized warranty or repair facility as designated by our Bellingham, Washington office with proof of their purchase of the product within two years, and provides Woodstock International, Inc. reasonable opportunity to verify the alleged defect through inspection. If it is determined there is no defect, or that the defect resulted from causes not within the scope of Woodstock International Inc.'s warranty, then the original owner must bear the cost of storing and returning the product.

This is Woodstock International, Inc.'s sole written warranty and any and all warranties that may be implied by law, including any merchantability or fitness, for any particular purpose, are hereby limited to the duration of this written warranty. We do not warrant that Shop Fox machinery complies with the provisions of any law, acts or electrical codes. We do not reimburse for third party repairs. In no event shall Woodstock International, Inc.'s liability under this limited warranty exceed the purchase price paid for the product, and any legal actions brought against Woodstock International, Inc. shall be tried in the State of Washington, County of Whatcom. We shall in no event be liable for death, injuries to persons or property or for incidental, contingent, special or consequential damages arising from the use of our products.

Every effort has been made to ensure that all Shop Fox machinery meets high quality and durability standards. We are committed to continuously improving the quality of our products, and reserve the right to change specifications at any time.

To register the warranty, go to <https://www.woodstockint.com/warranty>, or scan the QR code below. You will be directed to the Warranty Registration page on www.woodstockint.com. Enter all applicable production information.





High Quality Machines and Tools

Woodstock International, Inc. carries thousands of products designed to meet the needs of today's woodworkers and metalworkers.

Ask your dealer about these fine products:

BROSMAN
PRECISION STOP BLOCK

JOINTER PAL[®]

Rotacator[®]

STEELEX[®]
FINE TOOLS

PLANER PAL[®]

THE REBEL[®]

PRO-STIK[®]
ABRASIVE BELT & DISC CLEANER

BOARD BUDDIES[®]

WOODSTOCK
SHOP FOX[®]
INTERNATIONAL

STEELEX[®]
PLUS

SLICKPLANE[®]

Aluma-Classic[®]

ACCU-SHARP[®]

ROMAN
CARBIDE[®]

PARROT VISE[®]

WHOLESALE ONLY

WOODSTOCK INTERNATIONAL, INC.

Phone: (360) 734-3482 • Fax: (360) 671-3053 • Toll Free Fax: (800) 647-8801

P.O.Box 2309 • Bellingham, WA 98227

SHOPFOX.BIZ