

# TIN KNOCKER

## TK 2236 MANUAL ROLLS

### INSTRUCTIONS & PARTS DIAGRAMS



Shown with Optional Stand

### **TAAG MACHINERY CO.**

(Master Distributor)

1257-B Activity Dr.

Vista, CA 92081

Tel: (800) 640-0746 Fax: (760) 727-9948

Website: [www.tinknocker.com](http://www.tinknocker.com) \* Email: [taag@sbcglobal.net](mailto:taag@sbcglobal.net)

# **TIN KNOCKER SAFETY RULES TK 2236 MANUAL ROLLS**

1. Never use a machine or tool for anything other than its intended purpose. Use the proper tool and equipment for the task.
2. Do not remove, paint over, alter, or deface any machine-mounted warning and instruction plates and signs.
3. Do not operate the machine in excess of its rated capacity 36" X 22 gauge.
4. Beware of protruding machine elements or assemblies. Avoid any pinch-points created by the movement of the machine's components.

## **WARRANTY**

All new machines are sold with a one-year limited warranty, on factory defective parts. The warranty is limited to the original user. TAAG Machinery Co. at its option, will repair, replace or refund the purchase price of any part, tool or machine that fails during the warranty period. TAAG Machinery Co. will pay normal shipping charges for replacement parts. After 90 days from date of purchase, all express or overnight delivery charges are the responsibility of the customer. Purchaser must deliver to TAAG Machinery Co., at the address below, any written claim, with proof of original purchase. Replacement parts will be invoiced to purchaser and credit issued when the failed part is delivered to TAAG Machinery Co. Removal, reinstallation or replacement parts shall be at purchasers' / user's expense. Failure due to improper use of the machine voids the warranty.

**NOTE: 1.** This machine has been tested and adjusted prior to shipment, but can and often does require readjustment due to vibration and bouncing during transport. Following the procedures described within can easily do readjustment. These are procedures with which you, as a user, should be familiar, as you will use them repeatedly over the life use of the machine. If you have difficulty in performing these procedures, we are here to support you. Call us at: (800) 640-0746.

**2.** Opening rolls (for Philipsburg Lock) are consumable items and not subject to warranty.

## **TAAG MACHINERY CO.**

(Master Distributor)

1257-B Activity Dr.

Vista, CA 92081

Tel: (800) 640-0746 Fax: (760) 727-9948

Website: [www.tinknocker.com](http://www.tinknocker.com) \* Email: [taag@sbcglobal.net](mailto:taag@sbcglobal.net)

We disclaim any responsibility whatsoever to the customer or to any other person for injury to person, or damage to or loss of property or value, caused by any product which has been subjected to misuse, negligence, or accident; or misapplied; or modified or repaired by unauthorized persons; or improperly installed. We shall in no event be liable for any consequential damage, loss or expense arising from the use of, or inability to use, our product.

## Tin Knocker 2236 Rolls

Forming Machines, or Slip Roll Formers, are intended for rolling sheet metal or forming cylinders of various diameters.

The two pinch rolls feed the sheet against the rear roll, curving the sheet and forming the cylinder. The rear or forming roll can be adjusted by screws on the rear of left and right end housings, varying the diameter of the required cylinder. Pinch rolls can be adjusted for stock thickness by screws on front of end housings.

The capacity ratings of Tin Knocker forming machines are based on forming mild steel, fully annealed, the full length of the rolls and are considered as standard by the sheet metal trade for forming rolls of a specified diameter and length. Definite capacities, however, depend upon the diameter and length of cylinder to be formed and the number of passes through the rolls to obtain a given diameter. Stiffness of material and uniformity desired are also factors. When a forming machine is overloaded, the immediate result will be deflection in the center of the rolls, resulting in cylinders bulged in the center.

In order to reduce the number of rear roll adjustments when sheets are of light gauge, proceed as follows:

- 1) Insert the sheet between two pinch rolls.
- 2) Bend the sheet upwards and slightly around the top roll.
- 3) Continue to pass the sheet through the machine.

This will also reduce the flat spot on the leading edge of the sheet.

The right-hand housing is provided with a hinged journal cap and lifting latch. After the cylinder is formed, the latch is lifted and the lever is pressed down. This raises the top roll and the cylinder can be slipped off the roll without distortion.

Forming machines are provided with grooves in the right end of the lower and rear rolls to allow for forming cylinders with a wired edge.

**WARNING:** Before operating, machines must be bolted to work bench. If floor stand has been provided, machine must be bolted to floor stand with bolts provided. Stand must be securely lagged to floor.

## INSTRUCTIONS

**CAUTION:** Be sure that the machine is securely bolted onto pedestal or to customer supplied bench. Pedestal or workbench should be bolted to floor.

1. Adjust Lower Roll (11) to grip the metal firmly and evenly but without straining the machine. Lower Roll (11) is adjusted up or down with the two lower Adjusting Screws (29).
2. Adjust Rear Roll (12) to form the metal up as it travels through the rollers. Rear Roll (12) is adjusted up or down with the two rear Adjusting Screws (22). Be sure Rear Roll (12) is parallel with Lower Roll (11). If rolls are not parallel, the formed metal will be conical in shape instead of cylindrical.
3. Feed the stock to the rolls only from the front.
4. As the front rolls grip the stock, lift the rear end of the metal upward. This will help reduce the flat spot on the leading edge of the sheet and will also cause the leading edge to pass over the rear roll readily.
5. The diameter of the formed cylinder is determined by the position of the Rear Roll (12). To increase the diameter of a cylinder, lower Rear Roll (12) by turning the two-rear Adjusting Screws (22) counter clockwise. To reduce the diameter of a formed cylinder, raise Rear Roll (12) by turning the two rear Adjusting Screws (22) clockwise. The two rear Adjusting Screws (22) should be turned an equal number of turns in order to keep the Rear Roll (12) parallel with the front gripping rolls.
6. To remove a cylindrical piece without distorting it, lift up Locking Handle (27), raise Right Hand Housing Cap (1/2) and turn Cam Handle (15) down. This raises the outboard end of the Upper Roll (10) and allows the formed cylinder to be slipped off of the Upper Roll (10).
7. The Lower Roll (11) and the Rear Roll (12) have grooves of varying widths in one end. These are for the purpose of accommodating a wired edge when forming a shape or when forming wire into a ring.
8. "X" points should be lubricated daily with a good grade machine oil. "Y" points should be greased weekly with Alemite #33 or equal.

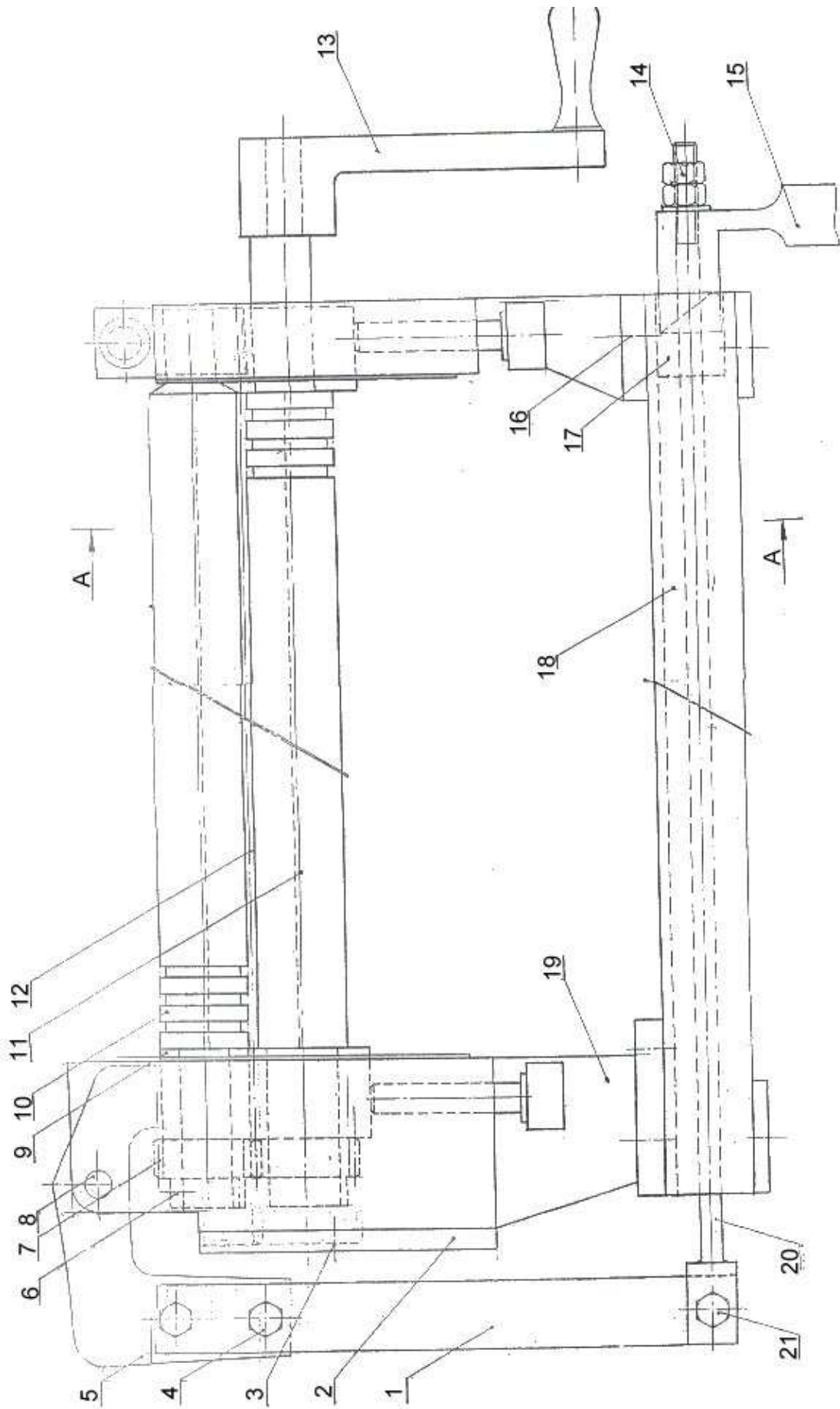

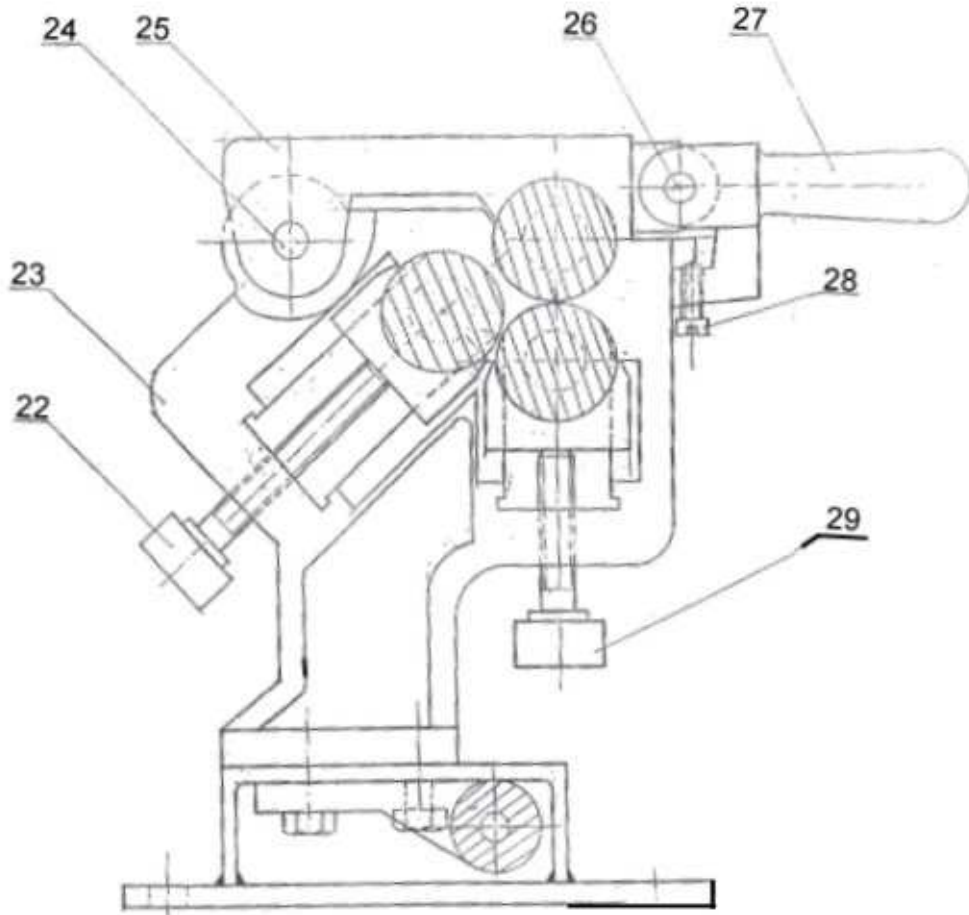

VIEW A-A

<b>Parts For 2236 ROLLS</b>			
<b>Fine No.</b>	<b>Part No.</b>	<b>Description</b>	<b>No. REQ"D.</b>
1	ROLL001	Lift Lever	1
2	ROLL002	Cover Plate	1
3	ROLL003	Bolt M8 x 25	2
4	ROLL004	Bolt M10 x 40	2
5	ROLL005	Rocking Box	1
6	ROLL006	Set Screw M6 x 25	3
7	ROLL007	Roll Gears	2
8	ROLL008	Rocking Box Pin	1
9	ROLL009	Box	4
10	ROLL010	Upper Front Roll	1
11	ROLL011	Lower Front Roll	1
12	ROLL012	Rear Roll	1
13	ROLL013	Crank Assembly Handle	1
14	ROLL014	Jam Nut	2
15	ROLL015	Cam Handle	1
16	ROLL016	Bolts M12 x 40	5
17	ROLL017	Cam	1
18	ROLL018	Machine Base Assembly	1
19	ROLL019	Left Hand Housing	1
20	ROLL020	Cam Rod	1
21	ROLL021	Bolt M10 x 30	1
22	ROLL022	Adjusting Screw Long	2
23	ROLL023	Right Hand Housing	1
24	ROLL024	Pin 16	1
25	ROLL025	Cap Right Hand Housing	1
26	ROLL026	Pin 12	1
27	ROLL027	Locking Handle	1
28	ROLL028	Locking Handle Screw	1
29	ROLL029	Adjusting Screw Short	2