

TIN KNOCKER

TK 1648 BOX & PAN BRAKE

INSTRUCTIONS & PARTS DIAGRAM



Shown with Optional Stand

TAAG MACHINERY CO.

(Master Distributor)

1257-B Activity Dr.

Vista, Ca 92081

Tel: (800) 640-0746 Fax: (760) 727-9948

Website: www.tinknocker.com * Email: taag@sbcglobal.net

**TIN KNOCKER
SAFETY RULES
TK 1648 BOX & PAN BRAKE**

1. Never use a machine or tool for anything other than its intended purpose. Use the proper tool and equipment for the task.
2. Do not operate the machine in excess of its rated capacity.
3. Never use a pipe or bar on the clamp or bending apron handles for additional leverage.
4. Keep clear of the counterweight and apron swing area, while operating the brake.

WARRANTY

All new machines are sold with a one-year limited warranty, on factory defective parts. The warranty is limited to the original user. TAAG Machinery Co. at its option, will repair, replace or refund the purchase price of any part, tool or machine that fails during the warranty period. TAAG Machinery Co. will pay normal shipping charges for replacement parts. After 90 days from date of purchase, all express or overnight delivery charges are the responsibility of the customer. Purchaser must deliver to TAAG Machinery Co., at the address below, any written claim, with proof of original purchase. Replacement parts will be invoiced to purchaser and credit issued when the failed part is delivered to TAAG Machinery Co. Removal, reinstallation or replacement parts shall be at purchasers' / user's expense. Failure due to improper use of the machine voids the warranty.

NOTE: 1. This machine has been tested and adjusted prior to shipment, but can and often does require readjustment due to vibration and bouncing during transport. Following the procedures described within can easily do readjustment. These are procedures with which you, as a user, should be familiar, as you will use them repeatedly over the life use of the machine. If you have difficulty in performing these procedures, we are here to support you. Call us at: (800) 640-0746.

2. Opening rolls (for Philipsburg Lock) are consumable items and not subject to warranty.

TAAG MACHINERY CO.

(Master Distributor)

1257-B Activity Dr.

Vista, Ca 92081

Tel: (800) 640-0746 Fax: (760) 727-9948

Website: www.tinknocker.com * Email: taag@sbcglobal.net

TK 1648 Box & Pan Brake,

RECEIVING THE MACHINE

Inspect before signing Bill of Lading. Upon receipt closely examine the machine for damage during shipment. Any loss or damage should be noted in detail on the delivery receipt and reported to your distributor immediately. Free replacement from TK International is dependant upon the notation and the Bill of Lading or delivery slip.

INSTALLING THE MACHINE

Locate the Brake in a well-lighted area on a solid, level floor. The Brake must be securely bolted to the floor. Be sure you have adequate room to swing both handles and Bending Leaf.

PRECAUTIONS

DO NOT use the Brake to bend rods, nails or wires. This will cause damage to the edge of the top blade. DO NOT exceed the capacity of the Brake.

OPERATING THE TK 1648 Box & Pan Brake

Your brake is a general-purpose tool for ending and forming sheet metal. The brake is operated in the following manner. Pushing the clamp handles toward the rear of the brake opens the holddown of the brake. Insert the material to be bent into the opening between the holddown and base assembly and clamp the material in place by pulling the clamp handles forward. Raise the apron to bend the material to the desired angle.

Allowing for metal thickness - The holddown assembly must be adjusted to allow for clearance when making bends according to the thickness of the material being formed. This adjustment is made by slightly releasing the clamping pressure on the clamp handles and moving the forward edge of the fingers back, away from the edge of the clamp block on the base. This movement is accomplished by loosening the bracket lock bolts – one on each end of the base assembly – and turning the adjusting bracket nuts to move the edge of the fingers toward or away from the edge of the clamp block. For 16 to 20 gauge materials allow a clearance equal to twice the thickness of the material being worked. For lighter gauges, allow a clearance equal to one and one half times the thickness of the material. A larger bend radius can be accomplished by increasing the clearance.

Clamping pressure – Clamping pressure should be adjusted according the thickness of the material being worked. A common cause of bending and forming problems is excessive clamping pressure. Clamping pressure should be adequate to hold the material securely in place but not so great as to require undue effort in locking the clamp handles. Clamping pressure is adjusted by turning the nuts on the threaded rod portion of the yoke assembly below the clamp swivel. The lift of the holddown assembly is adjusted by turning the nut above the clamp swivel. When the clamping pressure is properly adjusted, lock the nuts against the clamp swivel to prevent any change in adjustment.

Capacity – The capacity of the brake with the apron support angle attached is 16 gauge mild steel or 20-gauge stainless steel. The minimum recommended flange in capacity material with the apron support angle in place is one inch. The capacity of the brake is reduced by four gauges when the apron support angle is removed; i.e. 20 gauge mild steel or 24 gauge stainless. The capacity of the brake is reduced by seven gauges when the apron insert is removed. By removing the apron support angle and apron insert, narrow reverse bends are possible in lighter gauge materials.

Bending and repeat bends - Bending is accomplished by clamping the work piece under the holddown assembly so that the desired line of bend is held at the forward edge of the fingers and by elevating the apron assembly until the desired degree of bend is obtained. The maximum degree of bend is approximately 140 degrees. Due to the "spring back" in various materials some overbending may be required to get the desired bend angle. For repeat bends, adjust the stop on the stop rod to limit the swing of the apron assembly. The stop is secured in place with a setscrew.

Box and pan bending – The fingers can be removed and repositioned on the holddown assembly by moving the clamp handles fully to the rear and loosening the finger clamp screws. Reposition the fingers to assemble the desired width and secure the fingers to the holddown by tightening the finger clamp screws. Be certain that the tops of the fingers are flush and parallel with the milled edge on the holddown and that the finger clamps are parallel with the bottom edge of the holddown. As a general rule, use the wider fingers first and fill in with the narrower fingers. Small gaps between the fingers may be left with no adverse effect to the work piece. The maximum depth of the box or pan, which can be bent, is four inches.

Counterweight alignment – The counterweight on this brake can be adjusted to balance the apron for ease of operation. Loosen the setscrews and raise or lower the counterweight to achieve the desired degree of balance. Be certain to retighten the setscrews thus securing the counterweight in place.

Adjusting the Brake

Overbending – The holddown assembly should be moved back on the end where the overbending occurs by slightly unclamping the clamp handle, loosening the bracket lock screw and turning the adjusting bracket screw. When the correction is made retighten the bracket lock screw. When your brake was assembled at the factory it was adjusted for proper operation. Due to handling and repositioning, the brake may require adjustment and alignment. Read the adjustment and operating instructions completely before making any adjustments. Operate the brake and bend some material first before attempting any major adjustments.

Base alignment – The clamp block on the base of the brake should be straight. This is the reference point for all of the other alignment operations in adjusting the brake. Raise or lower the center of the brake by adjusting the center truss rods.

NOTE: Your brake has four truss rods, which facilitate adjustment of the brake's three primary weldments. The holddown has two truss rods bracing the top and rear of the weldment. Adjustments are accomplished through rotation of the nut located on the studs mounted perpendicular to the weldments.

Holddown Alignment – The forward edge of the fingers on the holddown assembly should be even and parallel to the edge of the clamp block on the base. Release any clamping pressure on the holddown assembly by pushing the clamp handles slightly to the rear. Loosen the bracket lock screws at each end of the holddown assembly and turn the adjustment bracket nuts to move the forward edge of the fingers to the forward edge of the clamp block. Check to see that the forward edge of the fingers are flush with the edge of the clamp block on the base along the entire length of the brake. The central portion of the holddown assembly can be adjusted forward/backward and up or down via truss rod adjustment.

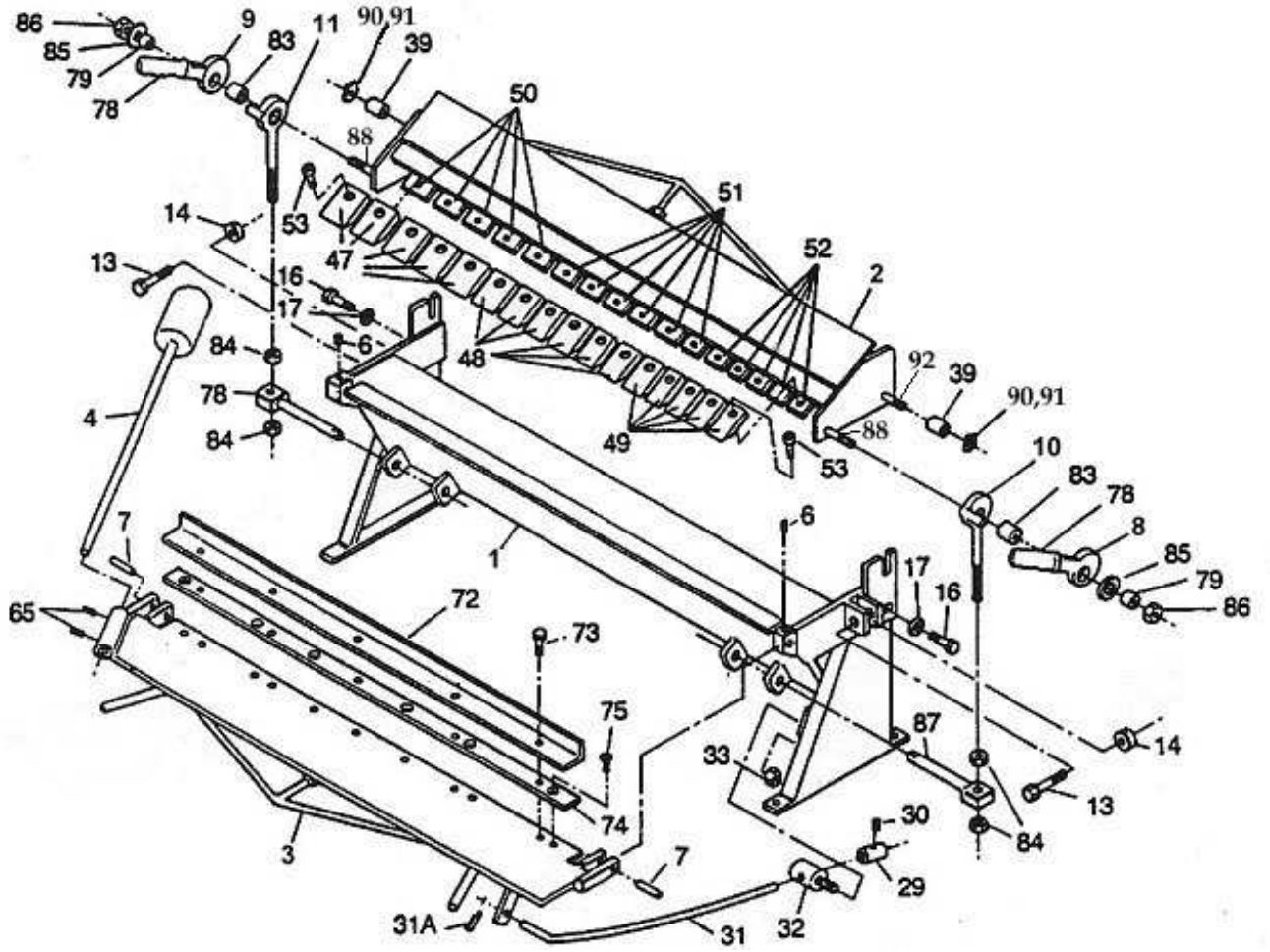

FINE NUMBERS FOR THE TK 1648 BOX AND PAN BRAKE

Parts For 1648 Box & Pan

Fine No.	Part No.	Description	No. REQ"D.
1	B&P1648001	BASE ASS'Y	1
2	B&P1648002	HOLDDOWN ASS'Y	1
3	B&P1648003	APRON ASS'Y	1
4	B&P1648004	C'Weight Ass'y	1
6	B&P1648006	SET SCREW HINGE BRKT.	2
7	B&P1648007	PIN HINGE	2
7A	B&P1648007A	PIN HINGE retainer ring	2
8	B&P1648008	R.H. CLAMP HANDLE ASS'Y	1
9	B&P1648009	L.H. CLAMP HANDLE ASS'Y	1
10	B&P1648010	R.H. YOKE ASS'Y	1
11	B&P1648011	L.H. YOKE ASS'Y	1
13	B&P1648013	SCREW BRKT. ADJ.	2
14	B&P1648014	NUT, ADJ. BRKT.	2
16	B&P1648016	SCREW, BRKT. LOCK	2
17	B&P1648017	WASHER, LOCK SCREW	2
29	B&P1648018	STOP	1
30	B&P1648019	SET SCREW, STOP	1
31	B&P1648020	STOP ROD	1
31A	B&P1648021	KEY, ROD	1
32	B&P1648022	STOP, SWIVEL	1
33	B&P1648023	NUT, SWIVEL	1
39	B&P1648024	BUSHING PIN	2
40	B&P1648025	RETAINER RING	2
47	B&P1648026	4" FINGER	5
48	B&P1648027	3" FINGER	6
49	B&P1648028	2" FINGER	5
50	B&P1648029	4" FINGER CLAMP	5
51	B&P1648030	3" FINGER CLAMP	6
52	B&P1648031	2" FINGER CLAMP	5
53	B&P1648032	SCREW, CLAMP	16
54	B&P1648033	HANDLE EXTENSION	0
65	B&P1648035	Set Screw, Holder	2
72	B&P1648036	SUPPORT ANGLE	1
73	B&P1648037	SCREW, ANGLE	5
74	B&P1648038	INSERT	1
75	B&P1648039	SCREW, INSERT	8
78	B&P1648040	HANDGRIP	2

79	B&P1648041	BUSHING, CAM	2
83	B&P1648042	BUSHING, YOKE	2
84	B&P1648043	NUT, YOKE ADJ.	4
85	B&P1648044	WASHER, CLAMP	2
86	B&P1648045	NUT, CLAMP	2
87	B&P1648046	SWIVEL, CLAMP	2
88	B&P1648050	Stud for Hold Down Assy	2
89	B&P1648051	LARGE WASHER	2
90	B&P1648052	Small Bolt	2
91	B&P1648053	Small Washer	2
92	B&P1648054	Pivot Stud	2