



Operating Instructions and Parts Manual 8-inch Woodworking Jointer

Models JWJ-8CS and JWJ-8HH



Model JWJ-8CS



Model JWJ-8HH

JET
427 New Sanford Road
LaVergne, Tennessee 37086
Ph.: 800-274-6848
www.jettools.com

Part No. M-718200
Edition 2 08/2016
Copyright © 2016 JET

Warranty and Service

JET warrants every product it sells against manufacturers' defects. If one of our tools needs service or repair, please contact Technical Service by calling 1-800-274-6846, 8AM to 5PM CST, Monday through Friday.

Warranty Period

The general warranty lasts for the time period specified in the literature included with your product or on the official JET branded website.

- JET products carry a limited warranty which varies in duration based upon the product. (See chart below)
- Accessories carry a limited warranty of one year from the date of receipt.
- Consumable items are defined as expendable parts or accessories expected to become inoperable within a reasonable amount of use and are covered by a 90 day limited warranty against manufacturer's defects.

Who is Covered

This warranty covers only the initial purchaser of the product from the date of delivery.

What is Covered

This warranty covers any defects in workmanship or materials subject to the limitations stated below. This warranty does not cover failures due directly or indirectly to misuse, abuse, negligence or accidents, normal wear-and-tear, improper repair, alterations or lack of maintenance. JET woodworking machinery is designed to be used with Wood. Use of these machines in the processing of metal, plastics, or other materials outside recommended guidelines may void the warranty. The exceptions are acrylics and other natural items that are made specifically for wood turning.

Warranty Limitations

Woodworking products with a Five Year Warranty that are used for commercial or industrial purposes default to a Two Year Warranty. Please contact Technical Service at 1-800-274-6846 for further clarification.

How to Get Technical Support

Please contact Technical Service by calling 1-800-274-6846. **Please note that you will be asked to provide proof of initial purchase when calling.** If a product requires further inspection, the Technical Service representative will explain and assist with any additional action needed. JET has Authorized Service Centers located throughout the United States. For the name of an Authorized Service Center in your area call 1-800-274-6846 or use the Service Center Locator on the JET website.

More Information

JET is constantly adding new products. For complete, up-to-date product information, check with your local distributor or visit the JET website.

How State Law Applies

This warranty gives you specific legal rights, subject to applicable state law.

Limitations on This Warranty

JET LIMITS ALL IMPLIED WARRANTIES TO THE PERIOD OF THE LIMITED WARRANTY FOR EACH PRODUCT. EXCEPT AS STATED HEREIN, ANY IMPLIED WARRANTIES OF MERCHANTABILITY AND FITNESS FOR A PARTICULAR PURPOSE ARE EXCLUDED. SOME STATES DO NOT ALLOW LIMITATIONS ON HOW LONG AN IMPLIED WARRANTY LASTS, SO THE ABOVE LIMITATION MAY NOT APPLY TO YOU.

JET SHALL IN NO EVENT BE LIABLE FOR DEATH, INJURIES TO PERSONS OR PROPERTY, OR FOR INCIDENTAL, CONTINGENT, SPECIAL, OR CONSEQUENTIAL DAMAGES ARISING FROM THE USE OF OUR PRODUCTS. SOME STATES DO NOT ALLOW THE EXCLUSION OR LIMITATION OF INCIDENTAL OR CONSEQUENTIAL DAMAGES, SO THE ABOVE LIMITATION OR EXCLUSION MAY NOT APPLY TO YOU.

JET sells through distributors only. The specifications listed in JET printed materials and on official JET website are given as general information and are not binding. JET reserves the right to effect at any time, without prior notice, those alterations to parts, fittings, and accessory equipment which they may deem necessary for any reason whatsoever. JET® branded products are not sold in Canada by JPW Industries, Inc.

Product Listing with Warranty Period

90 Days – Parts; Consumable items
1 Year – Motors; Machine Accessories
2 Year – Metalworking Machinery; Electric Hoists, Electric Hoist Accessories; Woodworking Machinery used for industrial or commercial purposes
5 Year – Woodworking Machinery
Limited Lifetime – JET Parallel clamps; VOLT Series Electric Hoists; Manual Hoists; Manual Hoist Accessories; Shop Tools; Warehouse & Dock products; Hand Tools; Air Tools

NOTE: JET is a division of JPW Industries, Inc. References in this document to JET also apply to JPW Industries, Inc., or any of its successors in interest to the JET brand.

Table of Contents

Warranty and Service.....	2
Table of Contents.....	3
Warning.....	4
Introduction.....	5
Levers and Controls.....	6
Specifications.....	6
Setup and Assembly.....	7
Unpacking and Cleanup.....	7
Installing Bed to Stand.....	8
Installing Pedestal Switch (<i>JWJ-8HH only</i>).....	8
Installing Handwheels.....	9
Assembling Knife-Setting Gauge (<i>JWJ-8CS only</i>).....	9
Installing V-Belts.....	9
Installing Cutterhead Guard.....	10
Installing Access Door.....	10
Installing Dust Chute.....	11
Electrical Connections.....	11
Extension Cords.....	11
Adjustments.....	12
90° Fence Adjustment.....	12
45° Fence Adjustment.....	12
Leveling Outfeed Table to Cutterhead Knives.....	13
Removing and Replacing Knives (<i>JWJ-8CS only</i>).....	14
Replacing or Rotating Knife Inserts (<i>JWJ-8HH only</i>).....	15
Infeed Table Depth Stop.....	16
Gib Adjustment.....	16
Operation.....	16
Jointing Warped Material.....	17
Direction of Grain.....	17
Bevel Cut.....	18
Taper Cut.....	18
Rabbet Cut.....	18
Maintenance.....	19
Lubrication.....	19
Blade Care.....	19
Sharpening Knives (<i>JWJ-8CS only</i>).....	19
Cutterhead Removal.....	19
Replacement Parts.....	20
Fence Assembly (all models).....	21
Parts List – Fence Assembly (all models).....	21
Bed Assembly (all models).....	22
Parts List – Bed Assembly (all models).....	23
Stand and Motor Assembly (<i>JWJ-8CS only</i>).....	24
Parts List – Stand and Motor Assembly (<i>JWJ-8CS only</i>).....	25
Stand and Motor Assembly (<i>JWJ-8HH only</i>).....	26
Parts List – Stand and Motor Assembly (<i>JWJ-8HH only</i>).....	27
Parts List – Cutterhead Assembly (<i>JWJ-8CS only</i>).....	28
Parts List – Cutterhead Assembly (<i>JWJ-8HH only</i>).....	29
Electrical Connections (<i>JWJ-8CS only</i>).....	30
Electrical Connections (<i>JWJ-8HH only</i>).....	31

Warnings

1. Read and understand the entire owner's manual before attempting assembly or operation.
2. Read and understand the warnings posted on the machine and in this manual. Failure to comply with all of these warnings may cause serious injury.
3. Replace the warning labels if they become obscured or removed.
4. This jointer is designed and intended for use by properly trained and experienced personnel only. If you are not familiar with the proper and safe operation of a jointer, do not use until proper training and knowledge have been obtained.
5. Do not use this jointer for other than its intended use. If used for other purposes, JET disclaims any real or implied warranty and holds itself harmless from any injury that may result from that use.
6. Always wear approved safety glasses/face shields while using this jointer. Everyday eyeglasses only have impact resistant lenses; they are not safety glasses.
7. Before operating this jointer, remove tie, rings, watches and other jewelry, and roll sleeves up past the elbows. Remove all loose clothing and confine long hair. Non-slip footwear or anti-skid floor strips are recommended. Do **not** wear gloves.
8. Wear ear protectors (plugs or muffs) during extended periods of operation.
9. Do not operate this machine while tired or under the influence of drugs, alcohol or any medication.
10. Make certain the switch is in the **OFF** position before connecting the machine to the power supply.
11. Make certain the machine is properly grounded.
12. Make all machine adjustments or maintenance with the machine unplugged from the power source.
13. Remove adjusting keys and wrenches. Form a habit of checking to see that keys and adjusting wrenches are removed from the machine before turning it on.
14. Keep safety guards in place at all times when the machine is in use. If removed for maintenance purposes, use extreme caution and replace the guards immediately.
15. Make sure the jointer is firmly secured to the stand or a bench before use.
16. Check damaged parts. Before further use of the machine, a guard or other part that is damaged should be carefully checked to determine that it will operate properly and perform its intended function. Check for alignment of moving parts, binding of moving parts, breakage of parts, mounting and any other conditions that may affect its operation. A guard or other part that is damaged should be properly repaired or replaced.
17. Provide for adequate space surrounding work area and non-glare, overhead lighting.
18. Keep the floor around the machine clean and free of scrap material, oil and grease.
19. Keep visitors a safe distance from the work area. **Keep children away.**
20. Make your workshop child proof with padlocks, master switches or by removing starter keys.
21. Give your work undivided attention. Looking around, carrying on a conversation and "horse-play" are careless acts that can result in serious injury.
22. Maintain a balanced stance at all times so that you do not fall or lean against the knives or other moving parts. Do not overreach or use excessive force to perform any machine operation.
23. Use the right tool at the correct speed and feed rate. Do not force a tool or attachment to do a job for which it was not designed. The right tool will do the job better and safer.
24. Use recommended accessories; improper accessories may be hazardous.
25. Maintain tools with care. Keep knives sharp and clean for the best and safest performance. Follow instructions for lubricating and changing accessories.
26. Turn off the machine and disconnect from power before cleaning. Use a brush or compressed air to remove chips or debris — do not use your hands.

27. Do not stand on the machine. Serious injury could occur if the machine tips over.
28. Never leave the machine running unattended. Turn the power off and do not leave the machine until it comes to a complete stop.
29. Remove loose items and unnecessary work pieces from the area before starting the machine.

⚠ WARNING: This product can expose you to chemicals including titanium dioxide which is known to the State of California to cause cancer, and lead which is known to the State of California to cause cancer and birth defects or other reproductive harm. For more information go to <http://www.p65warnings.ca.gov>.

⚠ WARNING: Drilling, sawing, sanding or machining wood products generates wood dust and other substances known to the State of California to cause cancer. Avoid inhaling dust generated from wood products or use a dust mask or other safeguards for personal protection.

Wood products emit chemicals known to the State of California to cause birth defects or other reproductive harm. For more information go to <http://www.p65warnings.ca.gov/wood>.

Familiarize yourself with the following safety notices used in this manual:

⚠ CAUTION This means that if precautions are not heeded, it may result in minor injury and/or possible machine damage.

⚠ WARNING This means that if precautions are not heeded, it may result in serious injury or possibly even death.

Introduction

This manual is provided by JET covering the safe operation and maintenance procedures for the JET Model JWJ-8CS and JWJ-8HH Woodworking Jointers. This manual contains instructions on installation, safety precautions, general operating procedures, maintenance instructions and parts breakdown. This machine has been designed and constructed to provide consistent, long-term operation if used in accordance with instructions set forth in this manual. If there are any questions or comments, please contact either your local supplier or JET. JET can also be reached at our web site: www.jettools.com.

Levers and Controls

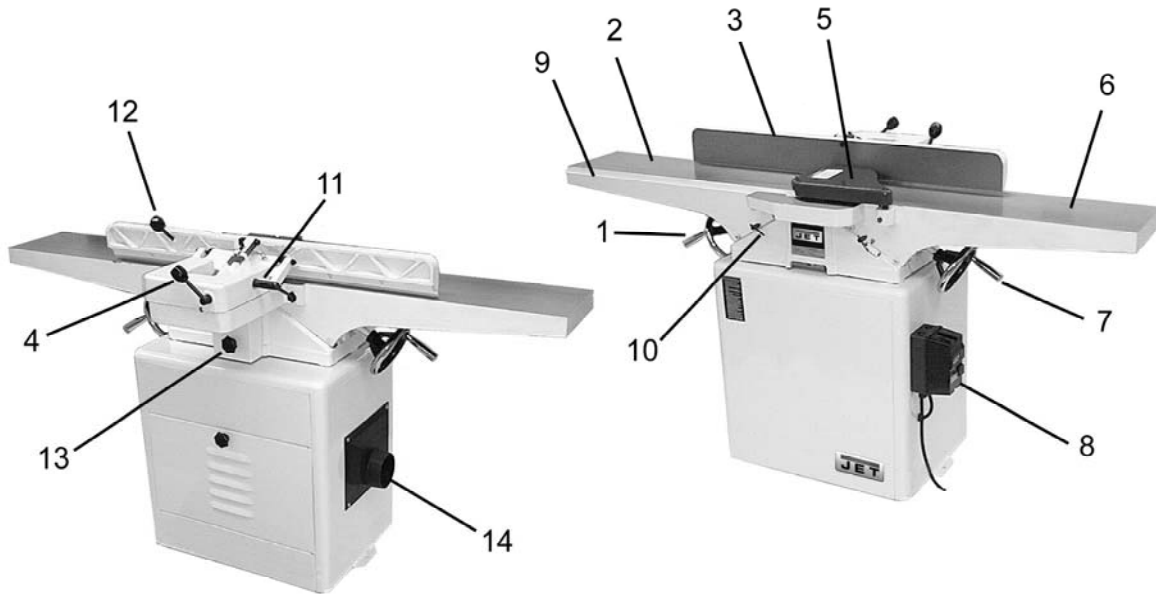

- | | |
|---|---|
| <ul style="list-style-type: none"> 1. Handwheel for Outfeed Table 2. Outfeed Table 3. Fence 4. Fence Adjustment Handle 5. Cutter Guard 6. Infeed Table 7. Handwheel for Infeed Table | <ul style="list-style-type: none"> 8. On/Off Switch (Pedestal style on JWW-8HH) 9. Rabbeting Ledge 10. Table Lock Knob 11. Fence Tilt Lock Handle 12. Fence Control Handle 13. Belt Guard 14. Dust Chute |
|---|---|

Specifications

Model	JWJ-8CS	JWJ-8HH
Stock Number – Bed and Stand Kit	718200K.....	718250K
Stock Number – Bed Assembly	718200J.....	718250J
Stock Number – Stand	718200S.....	718250S
Cutting Capacity	8"W x 1/2"D.....	8"W x 1/2"D
Cutterhead Speed	5500 RPM.....	5500 RPM
Number of Knives.....	3.....	36 knife inserts
Rabbeting Capacity	1/2"	not applicable
Rabbet Ledge.....	3-1/8" x 8-3/4".....	3-1/8" x 8-3/4"
Table Surface.....	9"W x 72"L.....	9"W x 72"L
Fence	4-3/4"W x 38-1/2"L.....	4-3/4"W x 38-1/2"L
Knife Size	8"L x 11/16"W x 1/8"T.....	15L x 15W x 2.5T mm
Fence Tilt.....	45°L, 45°R	45°L, 45°R
Positive Stops	45°L, 90°, 45°R.....	45°L, 90°, 45°R
Motor	2HP, 1Ph, 60Hz, 230V only.....	2HP, 1Ph, 60Hz, 230V only
Net Weight, Jointer and Stand (approx.).....	375 lbs.....	379 lbs
Shipping Weight, Jointer and Stand.....	452 lbs.....	456 lbs

The above specifications were current at the time this manual was published, but because of our policy of continuous improvement, JET reserves the right to change specifications at any time and without prior notice, without incurring obligations.

Setup and Assembly

Contents of Shipping Cartons

Note: Unit shipped in two cartons.

Stand Carton

- 1 Stand with Motor
- 1 Stand Door
- 1 Dust Chute with Mounting Hardware
- 1 Pedestal Switch with Mounting Hardware (*JWJ-8HH only*)

Main Unit Carton

- 1 Bed Assembly
- 1 Fence Assembly
- 1 Cutterhead Guard
- 1 Belt Guard
- 2 V-Belts
- 2 Handwheels with handle
- 1 Fence Handle
- 3 Mounting Bolts
- 3 3/8" Lock Washers
- 1 Operating Instructions and Parts Manual
- 1 Warranty Card

Tools Included with JWJ-8CS

- 1 12/14mm Open End Wrench
- 1 8/10mm Open End Wrench
- 3 Hex Wrenches (3, 4 and 5 mm)
- 1 Knife Gauge Assembly

Tools included with JWJ-8HH

- 1 12/14mm Open End Wrench
- 1 8/10mm Open End Wrench
- 4 Hex Wrenches (3, 4, 5, 6 mm)
- 2 Star Point Screwdrivers
- 5 Knife Inserts
- 10 Knife Insert Screws

Tools Required for Assembly:

- #1 Cross Point Screwdriver
- 6-8" Adjustable Wrench or 17 & 19mm Wrench

Unpacking and Cleanup

1. Carefully finish removing all contents from both shipping cartons. Compare contents of the shipping cartons with the list of contents above. Place parts on a protected surface.
2. Set packing material and shipping cartons to the side. Do not discard until machine has been set up and is running properly.
3. Clean all rust protected surfaces (bed, fence, etc.) with kerosene or diesel oil.



Do not use gasoline, paint thinner, mineral spirits, etc. These may damage painted surfaces.

WARNING Cutterhead knives are dangerously sharp! Use extreme caution when cleaning.

4. Apply a thin layer of paste wax to the bright surfaces of the fence and tables to prevent rust.

Installing Bed to Stand

1. Use an assistant or hoist mechanism to place bed assembly on top of stand. Be sure identification label on the bed faces the same direction as the label on the stand (Fig. 1).
2. Line up two holes in top of stand with holes in bed assembly by viewing through access door in stand.
3. Attach bed assembly to stand with two 3/8" lock bolts and lock washers (Fig. 2). Hand tighten only at this time.
4. Line up third hole in stand with hole in bed assembly by viewing through dust chute.
5. Install third 3/8" lock bolt and lock washer through dust chute to secure bed to stand.
6. Tighten all three mounting bolts with 14mm wrench.

Installing Pedestal Switch (JWJ-8HH only)

Referring to Figure 3:

1. The switch may be installed in either high position or low position to suit the operator. Slide the connection plug through the opening (A) and secure the pedestal switch using two 5/16"x3" screws (C) and 5/16" flat washers (B).
2. Connect the plug from the pedestal switch to the motor plug inside the cabinet.



Figure 1

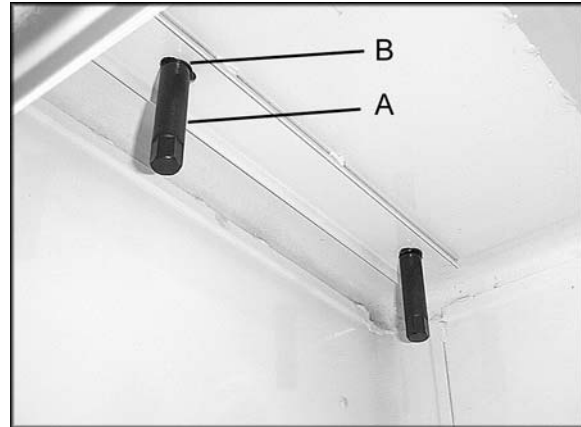

Figure 2

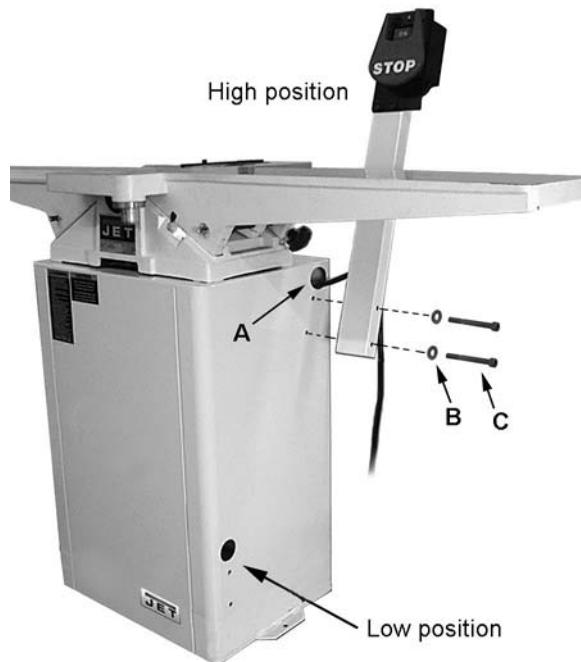

Figure 3

Installing Handwheels

1. Remove protective tape from shaft, and remove screw and washer.
2. Press handwheel (A, Fig. 4) onto shaft, aligning the keyway with the key. If necessary, use a hammer with a block of wood to tap the handwheel completely onto the shaft.
3. Re-install screw and washer (B, Fig. 4).
4. Mount handle (C, Fig. 4) onto handwheel.

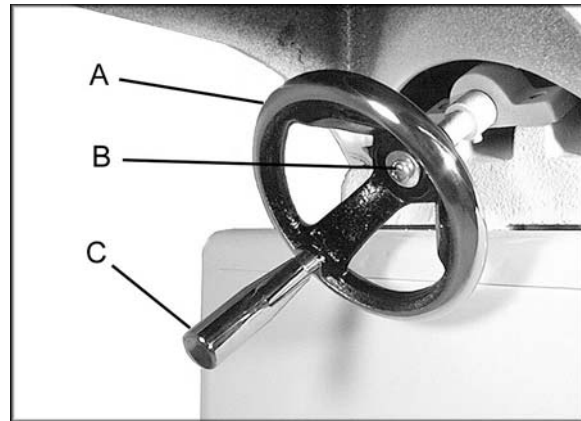

Figure 4

Assembling Knife-Setting Gauge (JWJ-8CS only)

Place the two bases (A, Fig. 5) onto each end of the bar (B, Fig. 5). Snap the four E-rings (C, Fig. 4) into the grooves on the bar as shown, one E-ring on each side of a base.

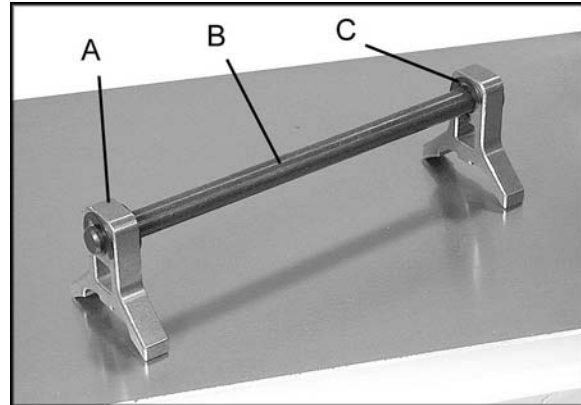

Figure 5

Installing V-Belts

1. Disconnect the machine from the power source, unplug.
2. Remove the lock knob (A, Fig. 6) and belt guard (B, Fig. 6).
3. Place v-belts onto cutterhead pulley grooves and through opening in stand.
4. Pull v-belts down and place onto motor pulley (Fig. 7). If necessary, loosen the mounting screws (A, Fig. 7) and slightly lift motor. Re-tighten the screws when belt is placed.
5. Check to make sure that motor pulley and cutterhead pulley are vertically aligned and the v-belt does not contact the sides of the opening in the base. If the pulleys are not aligned, loosen the screws (A, Fig. 7) on the motor base and slide the motor until the belt is aligned. Re-tighten screws.
6. The v-belt is properly tensioned when finger pressure on the belt half way between the two pulleys causes 1/2" deflection. If the belt is too loose, loosen the lower screws (B, Fig. 7) on the mounting plate and push down on the plate. When belt tension is correct, re-tighten screws.
7. After two hours of operation, check belt tension again. Re-tension if necessary.
8. Re-install belt guard and lock knob.

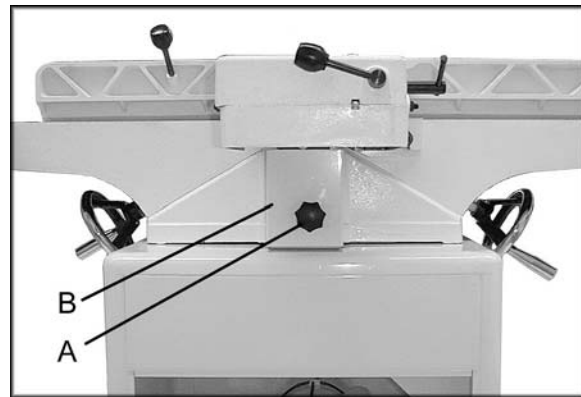

Figure 6

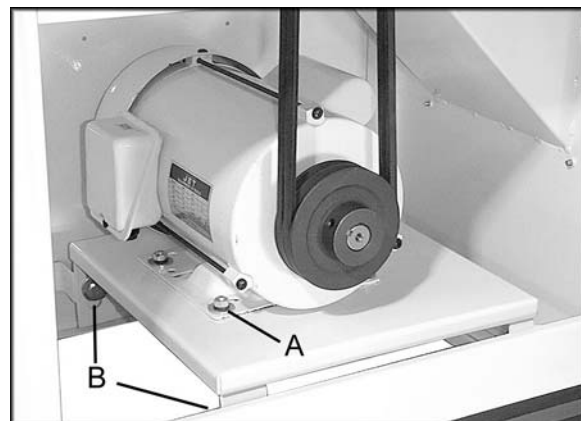

Figure 7

Installing Cutterhead Guard

The cutterhead guard has a spring tension mechanism which must be properly tensioned when installing the cutterhead guard on the machine.

To install the cutterhead guard:

1. Insert a small hex wrench, or similar object, into the pin on the guard tension mechanism (Figure 8-1).
2. Twist the hex wrench and pin clockwise, as shown in Figure 8-2, and hold them there.
3. Lower the shaft of the guard into the hole on the jointer's rabbeting ledge. See Figure 8-3. The guard should be lowered into the hole far enough that the groove in the guard's shaft will mate with the shaft of the set screw (Figure 8-3).
4. After the guard has been inserted into the hole, let go of the guard with your left hand - the guard will swing toward the fence.
5. Completely tighten the set screw (Figure 8-3), while continuing to hold the hex wrench and pin with your right hand.
6. When the guard is secured, remove the hex wrench from the pin. Slightly loosen the set screw (Figure 8-3) until the pin snaps back against the rabbeting ledge.
7. Re-tighten the set screw (Figure 8-3).

Installing Access Door

Install access door by placing bottom of panel into access in stand and fastening by turning latch (Fig. 9).

If the access door latch needs adjustment:

1. Remove the access door from the stand.
2. Loosen the hex lock nut (A, Fig. 9). Rotate the latch a quarter turn clockwise to tighten and counterclockwise to loosen.
3. Tighten the lock nut (A, Fig. 9).
4. Re-install the access door.

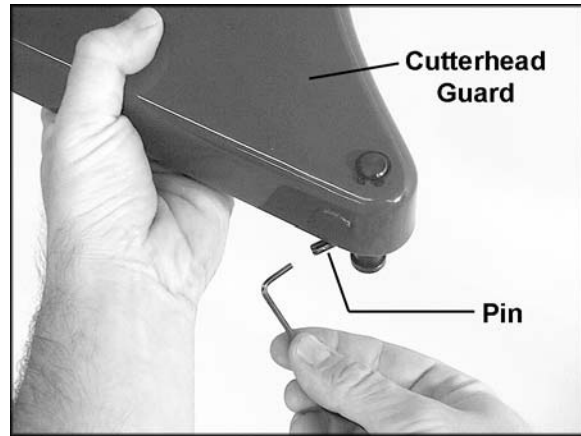

Figure 8-1

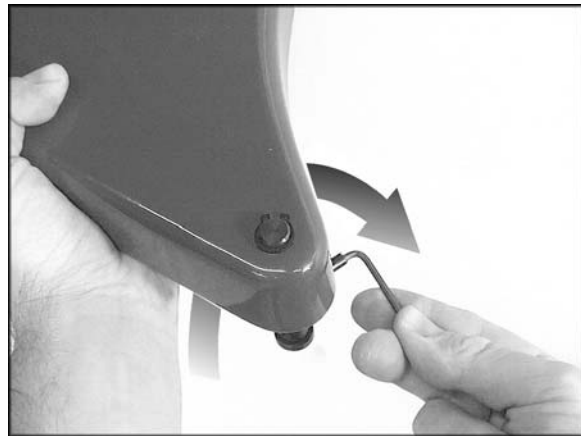

Figure 8-2

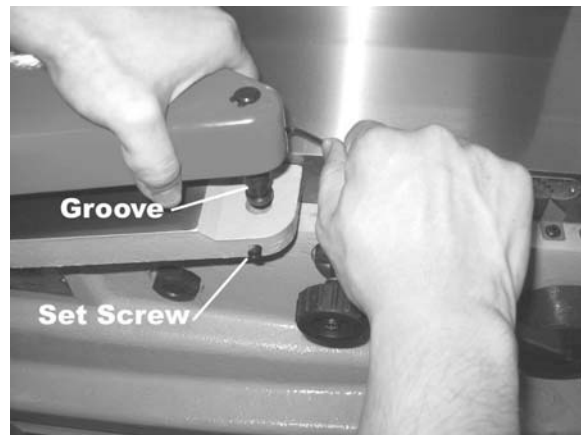

Figure 8-3

Installing Dust Chute

Attach the dust chute (Fig. 10) to the stand with four screws and four flat washers, through the pre-tapped holes in the stand.

Electrical Connections

⚠WARNING Electrical connections must be made by a qualified electrician in compliance with all relevant codes. This machine must be properly grounded to help prevent electrical shock and possible fatal injury.

Model JWJ-8CS: Remove the cover of the switch box (A, Fig. 11) and mount the box to the right side of the stand using the two screws provided. Insert the motor leads through the hole in the stand as shown, and insert a grommet (B, Fig. 11).

Consult the wiring diagram inside the switch box cover. The diagram is also on page 30 of this manual.

The JWJ-8CS and JWJ-8HH jointers are rated at 230V, single phase only. Confirm that the power at the source is compatible with the jointer before inserting plug into the outlet. The jointer is designed to be used with a plug and outlet similar to that shown in Fig. 12.

Important: Make certain the receptacle in question is properly grounded. If you are not sure, have a registered electrician check the receptacle.

Extension Cords

Make sure the rating of the extension cord is suitable for the amperage listed on the machine's motor plate. An undersize cord will cause a drop in line voltage resulting in loss of power and overheating.

Use the chart in Figure 13 as a general guide in choosing the correct size cord. If in doubt, use the next heavier gauge. The smaller the gauge number, the heavier the cord.

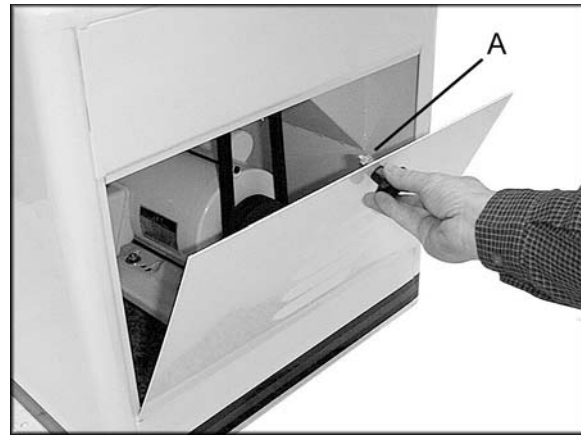

Figure 9



Figure 10

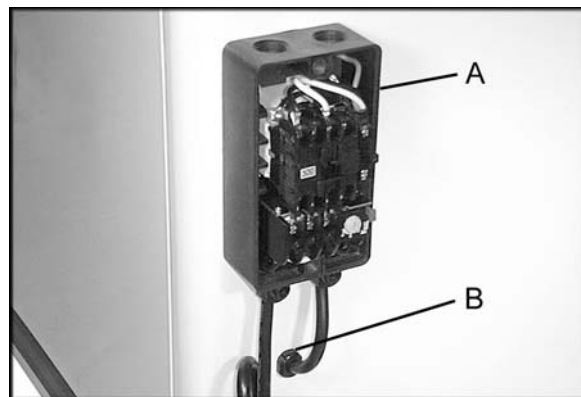

Figure 11

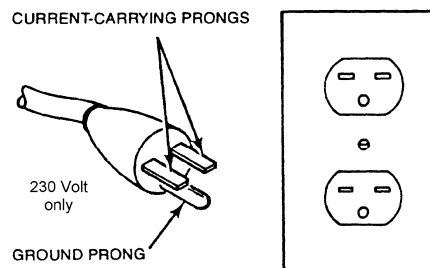

Figure 12

Adjustments

90° Fence Adjustment

Note: whenever making an adjustment to the fence, lift the fence up slightly after releasing the lock handle to avoid scratching the table.

1. Set infeed table to the same height as the outfeed table.
2. Move the fence by releasing lock handle (A, Fig. 14) and pushing the fence assembly until it overlaps the tables.
3. Adjust the fence to a 90° angle by releasing lock handle (B, Fig. 14), pulling up on handle (C, Fig. 14), and re-tightening lock handle (B, Fig. 14).
4. Place a combination square on the infeed table. (Fig. 15)
5. If fence is not square to table, release lock handle (B, Fig. 14), loosen nut (D, Fig. 14), and turn bolt (E, Fig. 14) until fence is square to table.
6. Tighten nut (D, Fig. 14) to retain the setting. Tighten lock handle (B, Fig. 14).

45° Fence Adjustment

Note: Whenever making an adjustment to the fence, lift the fence up slightly after releasing the lock handle to avoid scratching the table.

1. Loosen lock handle (A, Fig. 16). Move the stop plate (B, Fig. 16) out of the way and position the fence at the 45° angle. Make sure the fence sits against the stop bolt (C, Fig. 16).
2. Place a combination square (D, Fig. 16) on the fence and table to confirm a 45° setting.
3. To adjust, loosen lock nut (E, Fig. 16), turn bolt (C, Fig. 16) until a 45° angle is obtained, and tighten lock nut (E, Fig. 16). Tighten lock handle (A, Fig. 16).

Recommended Extension Cord Gauges (AWG)

Amps	Extension Cord Length in Feet *					
	25	50	75	100	150	200
< 5	16	16	16	14	12	12
5 to 8	16	16	14	12	10	NR
8 to 12	14	14	12	10	NR	NR
12 to 15	12	12	10	10	NR	NR
15 to 20	10	10	10	NR	NR	NR
21 to 30	10	NR	NR	NR	NR	NR

*based on limiting the line voltage drop to 5V at 150% of the rated amperes.

NR: Not Recommended.

Figure 13

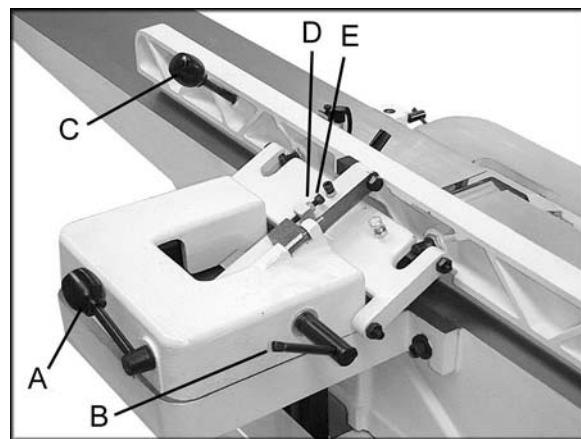

Figure 14

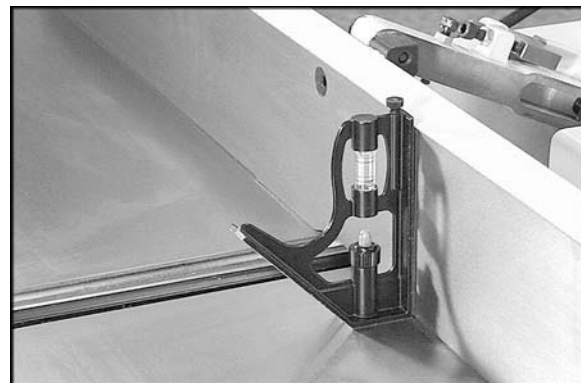

Figure 15

Leveling Outfeed Table to Cutterhead Knives

⚠WARNING Machine should be disconnected from power source at this time! Cutterhead blades are extremely sharp! Use caution when hands are near the cutterhead!

For most jointing operations, the surface of the outfeed table must be level with the knife tips of the cutterhead at their highest point of revolution. The knife tips must project equally from the cutterhead.

The outfeed table and cutterhead are adjusted at the factory and should not require adjustment.

1. On the JWJ-8CS Jointer, carefully number each blade with a magic marker to make them easier to differentiate.
2. Rotate the cutterhead by turning the cutterhead pulley and determine the 12 o'clock position of knife number one (or a knife insert on the JWJ-8HH model). The 12 o'clock position is the highest point a blade will reach in the cutting arc.
3. Loosen table lock screw (A, Fig. 17) and raise the outfeed table to the height of blade number one by turning handwheel (B, Fig. 17). Counter-clockwise will cause the outfeed table to raise. Clockwise will cause the outfeed table to lower. Set a straight edge (C, Fig. 17) on the outfeed table and across the cutterhead.
4. Position of the table and straight edge should look like Figure 18. Use care when handling the straight edge near the blades so as not to damage them.
5. When the outfeed table and blade number one (or knife insert) are the same height, tighten table lock screw.

After the outfeed table has been set, the JWJ-8HH will need no further adjustments to the cutterhead – skip steps 6 through 9 below. The JWJ-8CS must have its knives parallel with the outfeed table. Proceed as follows:

6. Bring the straight edge forward to the front of the outfeed table and confirm that blade number one is at the same height at the front of the table as it is at the back of the table.

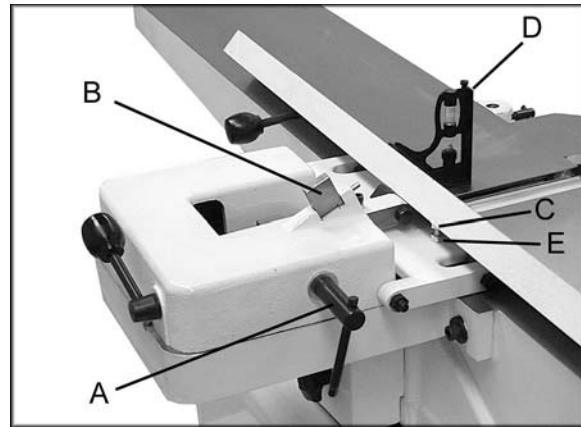

Figure 16

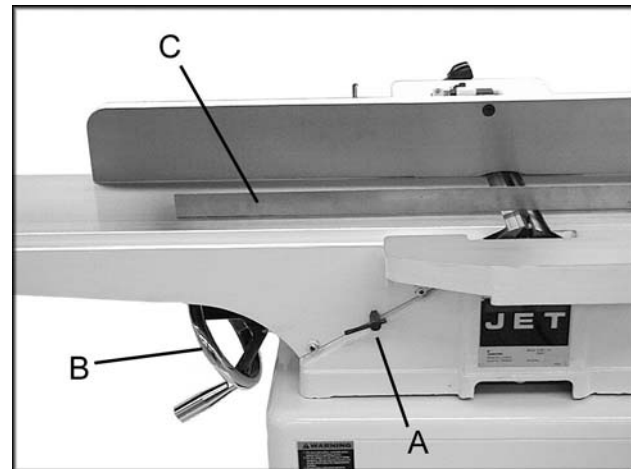

Figure 17

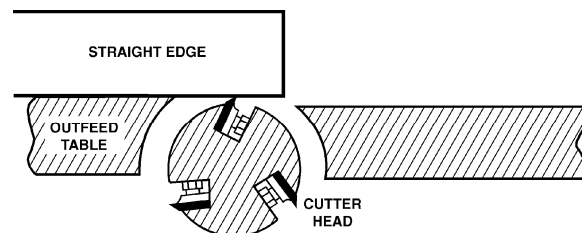

Figure 18

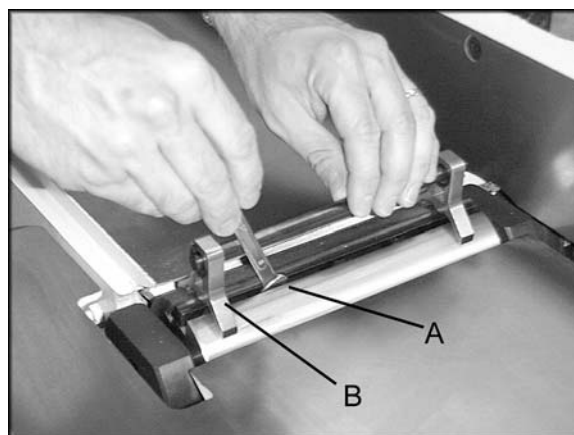

Figure 19

7. If blade is higher or lower at one point, slightly loosen five screws (A, Fig. 19) by turning clockwise as viewed from the infeed table.
8. Place the knife setting gauge (B, Fig. 19) on the cutterhead over the blade. Continue loosening the five screws until the springs push the knife up into contact with the gauge. Alternately tighten the five screws to hold each blade in place.
9. Repeat this process with blades two and three. The outfeed table and cutterhead knives are correctly adjusted when all three blades are parallel to the outfeed table and all three blades are set at the same height in the cutterhead.

After the outfeed table has been set at the correct height, do not change it except for special operations or after replacing the knives.

If the outfeed table is set too high, a curved finished surface results. (Fig. 20)

If the outfeed table is set too low, gouging results at the end of the cut. (Fig. 21)

Figure 22 illustrates the outfeed table at the correct height.

Removing and Replacing Knives (JWJ-8CS only)

⚠WARNING Disconnect the machine from the power source before making any adjustment or repair. All knife lock bolts must be firmly tightened or risk ejection of the knife(s) and lock bar from the cutterhead! Failure to comply may cause serious injury!

1. Disconnect machine from power source.
2. Remove blade guard by loosening set screw (A, Fig. 23) and lifting up on blade guard. **Caution: blades are sharp! Use great care when hands are around blade area!**
3. Loosen the five lock screws (Fig. 24). Note: Loosen screws by turning in a clockwise direction as viewed from the infeed table. Carefully remove the knife (A, Fig. 25), and the lock bar with screws (B, Fig. 25). Repeat for the other two blades.

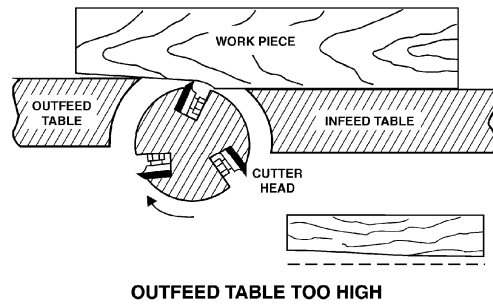

Figure 20

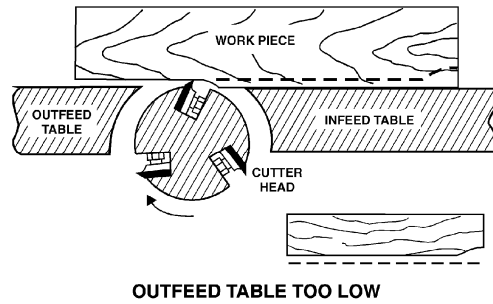

Figure 21

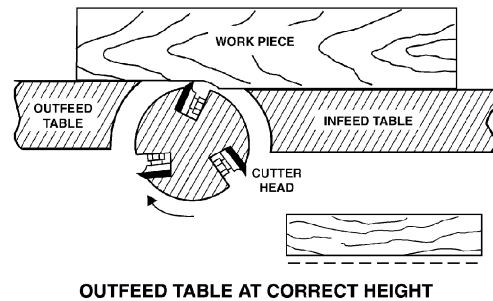

Figure 22



Figure 23

4. Before assembly, clean all parts thoroughly and clear cutterhead knife slots of any dust or debris.
5. Insert knife into the cutterhead channel making sure it faces the proper direction.
6. Insert lock bar and screws and tighten to hold in place. Blades are set at the proper height when the top of the blade is 1/16" above the cutterhead.
7. Repeat for other two blades.
8. To set the knives to the outfeed table and to the same height in the cutterhead, see section titled "Leveling Outfeed Table to Cutterhead Knives" found on page 12 of this manual.

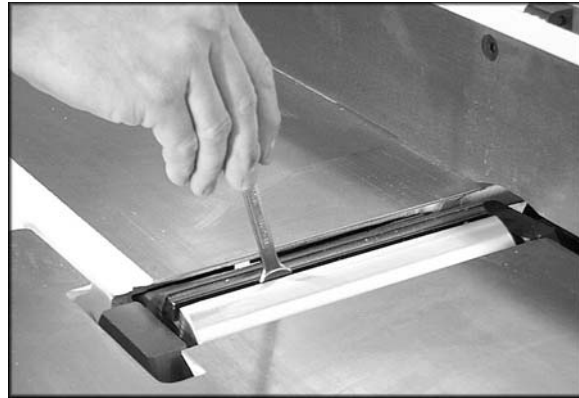

Figure 24

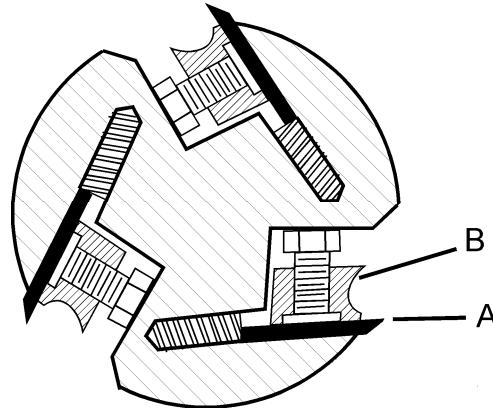

Figure 25

Replacing or Rotating Knife Inserts (JWJ-8HH only)

The knife inserts on the model JWJ-8HH Jointer are four-sided. When dull, simply remove each insert, rotate it 90° for a fresh edge, and re-install it.

Use the two provided star point screwdrivers to remove the knife insert screw. See Figure 26. Use one of the screwdrivers to help hold the cutterhead in position, and the other to remove the screw. It is advisable to rotate all inserts at the same time to maintain consistent cutting. However, if one or more knife inserts develops a nick, rotate only those inserts that are affected.

Each knife insert has an etched reference mark so that you can keep track of the rotations.

IMPORTANT: When removing or rotating inserts, clean saw dust from the screw, the insert, and the cutterhead platform. Dust accumulation between these elements can prevent the insert from seating properly, and may affect the quality of the cut.

Before installing each screw, lightly coat the screw threads with machine oil and wipe off any excess.

Securely tighten each screw which holds the knife inserts before operating the planer!

WARNING Make sure all knife insert screws are tightened securely. Loose inserts can be propelled at high speed from a rotating cutterhead, causing injury.

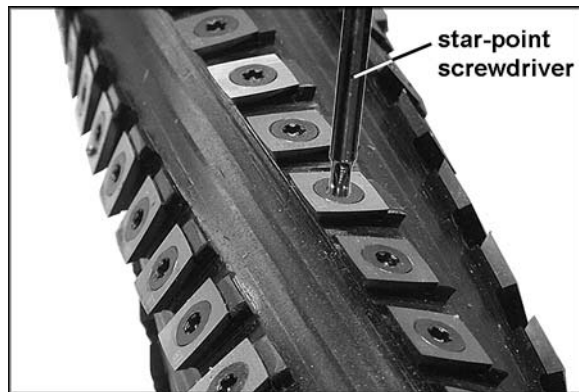

Figure 26

Infeed Table Depth Stop

Referring to Figure 26a:

The *infeed table travel limiter* located on the back of the table sets the upper and lower range for the infeed table height adjustment and should not require any adjustments.

The *infeed table depth stop* (A) limits the depth of a cut (set by adjusting the infeed table handwheel) to a maximum depth of 1/8". For normal operations, the depth of cut should never exceed 1/8", except for rabbeting operations.

If a rabbeting operation is desired:

1. Lower the infeed table to 1/8", which will cause the depth stop limiter to engage.
2. Loosen the lock handle (B) and pull out on the stop handle (C).
3. Continue lowering the table to the desired depth of cut.

Important: Never override the depth stop limiter unless performing rabbeting operations.

Gib Adjustment

After a period of use, the gibs may become loose and need adjusting:

1. Loosen three lock nuts (A, Fig. 27) and gib lock screw (B, Fig. 27)
2. Tighten each set screw 1/4 turn starting at the bottom and working up. If a 1/4 turn does not remove all play, take another 1/4 turn. Repeat a 1/4 turn at a time for all three set screws until play is removed.
3. Tighten lock screw (B, Fig. 27) and lock nuts (A, Fig. 27).

Operation

⚠WARNING Keep all guards in place and in adjustment at all times during the cutting procedure! Keep hands away from the cutterhead! Do not pass hands directly over the cutterhead! The use of push sticks and/or handle pads are highly recommended when using the jointer! Failure to comply may cause serious injury!

Jointing cuts or edge jointing are made to square an edge of a workpiece. The workpiece is positioned on the jointer with the narrow edge of the workpiece on the

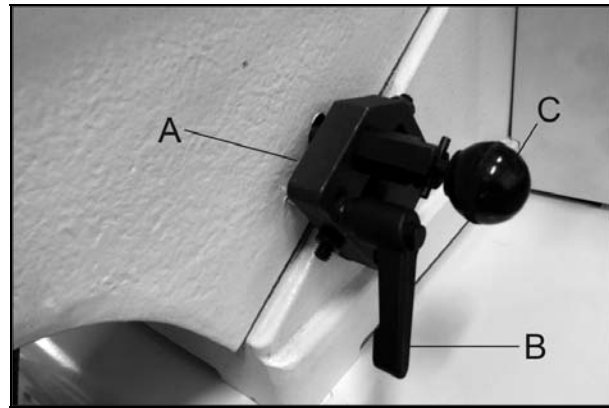

Figure 26a

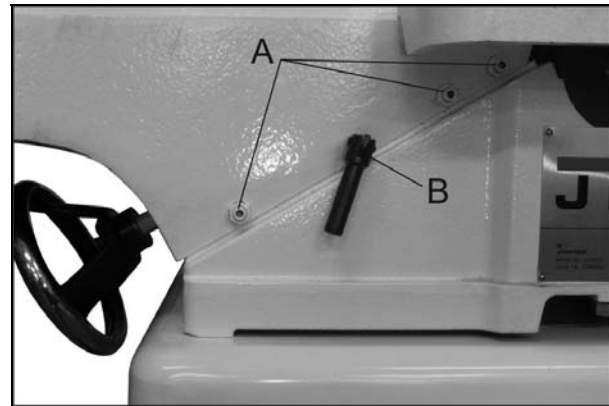

Figure 27

infeed table and the major flat surface of the workpiece against the fence (Fig. 28).

Planing cuts are similar. The major surface of the workpiece is placed on the table with the narrow edge of the workpiece against the fence (Fig. 29).

For jointing and planing cuts pressure is directed three ways; into the fence to ensure a square cut, forward to advance the stock, and downward to avoid chatter and vibration.

For jointing when the material is higher than the fence, the left hand applies pressure into the fence and down toward the table while the right hand pushes forward from behind. Be sure to keep the right hand high up on the material. (Fig. 28)

For jointing material that is lower than the fence, use push sticks to protect the hands. For planing, use handle pads. (Fig. 29) **Never place the right hand on the trailing edge of the material. Hand placement on the trailing edge of the material may cause the hand to come into contact with the blade.**

Feed work from right to left at a steady, moderate speed. If you feed the material too slowly, the wood will burn in places. If you feed the material too quickly, ridges will appear in the finished surface.



Figure 28



Figure 29

Jointing Warped Material

If the work to be jointed is cupped or warped, take light, repetitive cuts until the surface is flat. Forcing the material flat against the table will still leave a warped piece after the cuts have been made.

⚠WARNING Never joint any material shorter than eight inches! The material may tip into the jointer's throat and be kicked back! Avoid jointing thin material which could become jammed under the fence or blade guard! Failure to comply may cause serious injury!

Direction of Grain

Feed the material with the grain to avoid tearout (Fig. 30). If the direction of the grain changes somewhere in the board, try reducing depth of cut and slow the feed speed down to avoid tearout. If results still aren't satisfactory, turn the material around and try feeding through the other way.

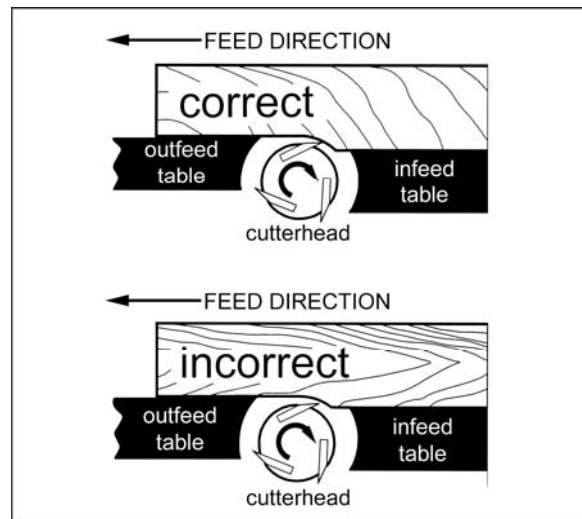

Figure 30

Bevel Cut

To cut a bevel, lock the fence at the desired angle and run the material through, pressing the work firmly against the fence and tables (Fig. 31). Several passes may be necessary for the desired result.

Taper Cut

⚠WARNING Taper cuts require the removal of the cutterhead guard. Use extreme caution when making taper cuts and replace the guard immediately after completion! Failure to comply may cause serious injury!

One of the most useful jointer operations is cutting an edge to a taper. This method can be used on a wide variety of work; tapered legs of furniture is a common example.

Instead of laying the piece down on the infeed table, lower the forward end of the work onto the outfeed table. Use caution, however, as the piece will span the knives, and they will take a "bite" from the work with a tendency to kick back unless the piece is held firmly. Push the work forward as in ordinary jointing. The effect is to plane off all the stock in front of the knives to an increasing depth, leaving a tapered surface.

The ridge left by the knives when starting the taper may be removed by taking a very light cut in the regular jointing procedure, with the infeed table raised to its normal position.

Practice is required in this operation. Beginners are advised to make trial cuts with scrap material.

Rabbet Cut

⚠WARNING Rabbeting requires the removal of the cutterhead guard. Use extreme caution when making rabbeting cuts and replace the guard immediately after completion! Failure to comply may cause serious injury!

Note: Rabbet cuts are not applicable with the Model JWJ-8HH Jointer with helical head.

1. Adjust the fence so that the distance between the end of the knives and fence is equal to the width of the rabbet (Fig. 32).



Figure 31

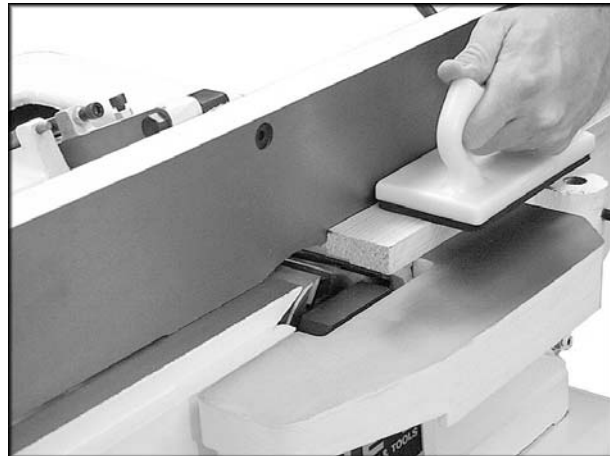

Figure 32

2. Lower the infeed table an amount equal to the depth of the rabbet. If the rabbet is quite deep, it may be necessary to cut in two or more passes.
3. In that event, the table is lowered an amount equal to about half the depth of the rabbet for the first pass, then lowered again to proper depth to complete the cut.

Maintenance

Lubrication

1. Use a good grade of light grease on the steel adjusting screws located in the raising and lowering mechanisms of the work tables.
2. Occasionally, apply a few drops of light machine oil to the gibs. This permits the tables to slide freely.
3. The cutterhead ball bearings are lifetime lubricated and need no further care.

Blade Care

⚠WARNING Blades are extremely sharp! Use caution when cleaning or changing. Failure to comply may cause serious injury!

When gum and pitch collect on the blades, carefully remove with a strong solvent. Failure to remove gum and pitch build-up may result in excessive friction and overheating.

Sharpening Knives (*JWJ-8CS only*)

When blades become dull, touch up blades.

1. Disconnect the machine from the power source.
2. Remove the fence, blade guard and belt cover.
3. To protect the infeed table from scratches, partially cover the sharpening stone with paper. (Fig. 33)

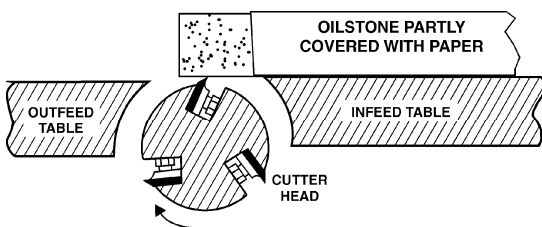

Figure 33

4. Lay the stone on the infeed table.
5. Lower the infeed table and turn the cutterhead by turning the cutterhead pulley. The infeed table height is set properly when the stone's surface is flush with the knife bevel.
6. Keep the cutterhead from rotating by grasping the cutterhead pulley while sliding the stone back and forth across the table.

7. Take the same amount of passes for all three blades.

When the blades have been sharpened, if they still are not cutting efficiently, trying to touch up the blades further will only cause the formation of a second beveled edge. When this starts to happen, it is time to replace blades with another set.

It is recommended to keep a second set of blades on hand so that they may be installed while the first set is being professionally sharpened.

Cutterhead Removal

⚠WARNING Blades in the cutterhead are sharp! Use extreme caution when handling the removal of the cutterhead. Failure to comply may cause serious injury!

The entire cutterhead assembly may be removed for cleaning or for bearing and blade replacement. Some woodworkers keep a spare cutterhead with replacement blades should the original cutterhead have to be repaired.

To remove the cutterhead (including bearings, studs, and housing) from the base casting:

1. Disconnect the machine from the power source.
2. Remove the fence assembly, cutterhead guard, and belt guard.
3. Remove the v-belt from the cutterhead pulley.
4. Loosen set screw (A, Fig. 34) using a hex wrench and remove the cutterhead pulley (B, Fig. 34) and key (C, Fig. 34).

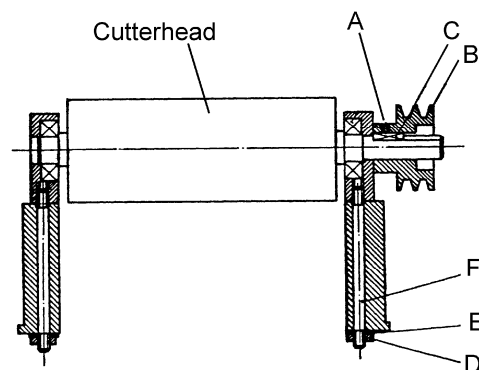

Figure 34

5. Remove nuts (D, Fig. 34) and lock washers (E, Fig. 34).
6. Lift assembly straight up. Studs (F, Fig. 34) will still be attached to the bearing housings.

7. Before replacing the cutterhead back into the casting, thoroughly clean the “saddle” and the bearing housings of saw dust and grease so that they seat properly.

8. To re-install the cutterhead, reverse the above steps.

Troubleshooting

Trouble	Probable Cause	Remedy
Finished stock is concave on the end.	Knife tip is higher than outfeed table.	Raise outfeed table so it is level with knife tip.
Back side of finished stock is thicker than the front side.	Outfeed table is higher than knife tip.	Adjust outfeed table so it is level with knife tip.
Stock is concave in the middle.	Table flatness should be checked with a machinist’s square.	Adjust the screws below the table to raise the table ends.
Both ends of finished stock are cut deeper than the middle.	Ends of tables are higher than middle.	Raise table ends with adjustment screws below tables.
Infeed or outfeed tables are loose.	Loose gib.	Tighten gibs.
Ripples on planed surface. Kickbacks	One blade set higher than the others.	Readjust blades
	Feeding wood too fast.	Feed wood more slowly.
	Cutting blades are set too high above outfeed table, or they may not be level with outfeed table. (JWJ-8CS)	Readjust blades (JWJ-8CS).
Excessive motor noise.	Motor	Have motor checked by a qualified repair station.
	Pulley set screw is loose.	Tighten set screw.
Motor fails to develop full power or stalls.	Circuit overloaded with lights, tools, etc.	Do not share the circuit.
	Undersize wires or circuit too long.	Increase wire sizes, or reduce length of wiring.
	Voltage too low.	Request voltage check from the power company.
	Fuses or circuit breakers do not have sufficient capacity.	Have a qualified electrician install proper size fuses or circuit breakers.
Motor starts slowly or fails to come to full speed.	Motor	Have motor checked by a qualified repair station.
	Belt tension too tight.	Adjust belt tension.
	Bad start capacitor.	Replace start capacitor.

Replacement Parts

Replacement parts are listed on the following pages. To order parts or reach our service department, call 1-800-274-6848 Monday through Friday, 8:00 a.m. to 5:00 p.m. CST. Having the Model Number and Serial Number of your machine available when you call will allow us to serve you quickly and accurately.

Fence Assembly (all models)

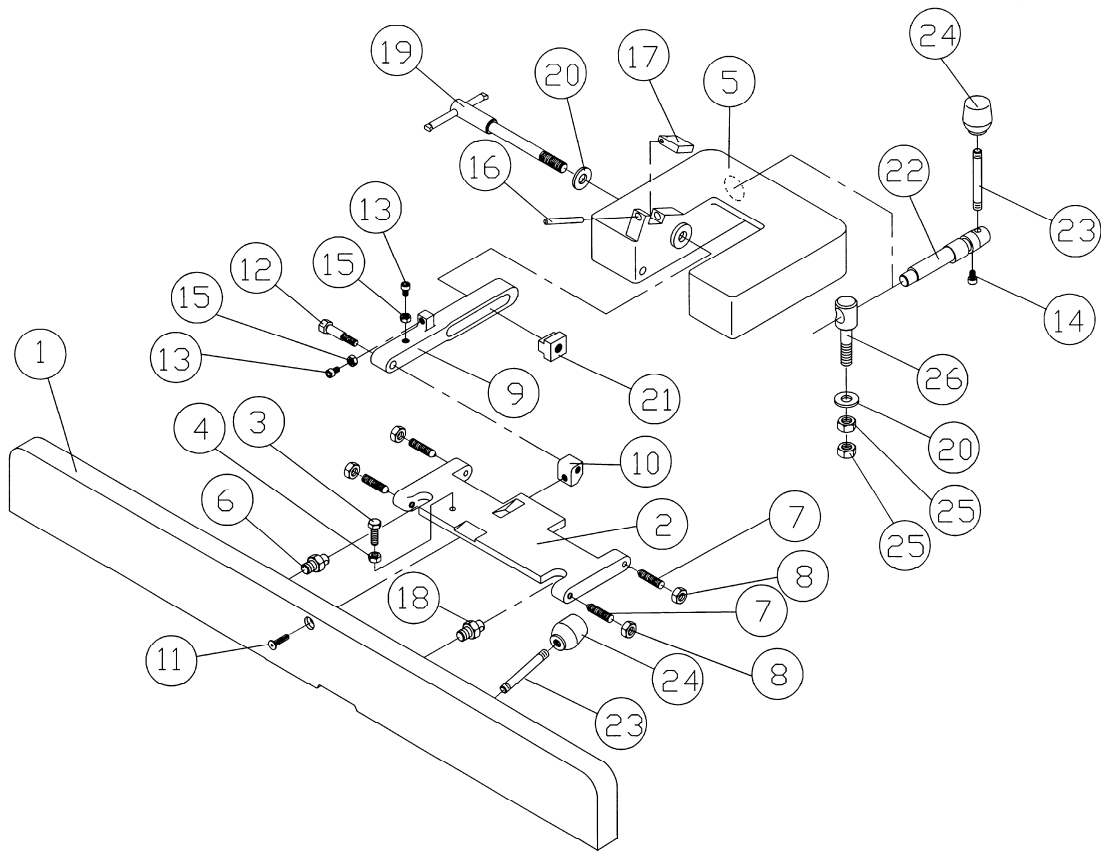

Parts List – Fence Assembly (all models)

Index No.	Part No.	Description	Size	Qty
1	JWJ8CS-101	Fence Body		1
2	JC-F02	Fence Link		1
3	TS-0051061	Hex Head Screw	5/16"-18 x 1-1/4"	1
4	TS-0561021	Nut	5/16"-18	1
5	JC-F03	Fence Bracket		1
6	JC-F04	Bolt		2
7	JC-F05	Bolt	3/8"-16	4
8	TS-0561031	Nut	3/8"	4
9	JC-F06	Locking Link		1
10	JC-F07	Joint Plate		1
11	5C-E051	Flat Head Bolt	5/16"-18 x 1-1/2"	1
12	JC-F08	Screw		1
13	TS-0207081	Socket Head Cap Screw	1/4"-20 x 1-1/2"	2
14	TS-0207021	Socket Head Cap Screw	1/4"-20 x 1/2"	1
15	TS-0050061	Nut	1/4"-20	2
16	JC-F09	Pin	5x50	1
17	JC-F10	Stop Block		1
18	TS-0561052	Nut	1/2"-20	2
19	JC-F11	Locking Bolt w/Handle		1
20	TS-0680061	Flat Washer	1/2"	2
21	6296081	Nut		1
22	JC-F14	Eccentric Shaft		1
23	JC-F15	Handle		2
24	LA-H34	Knob		2
25	6296083	Hex Nut	1/2"-12	2
26	JC-F16	Eye Bolt		1

Bed Assembly (all models)

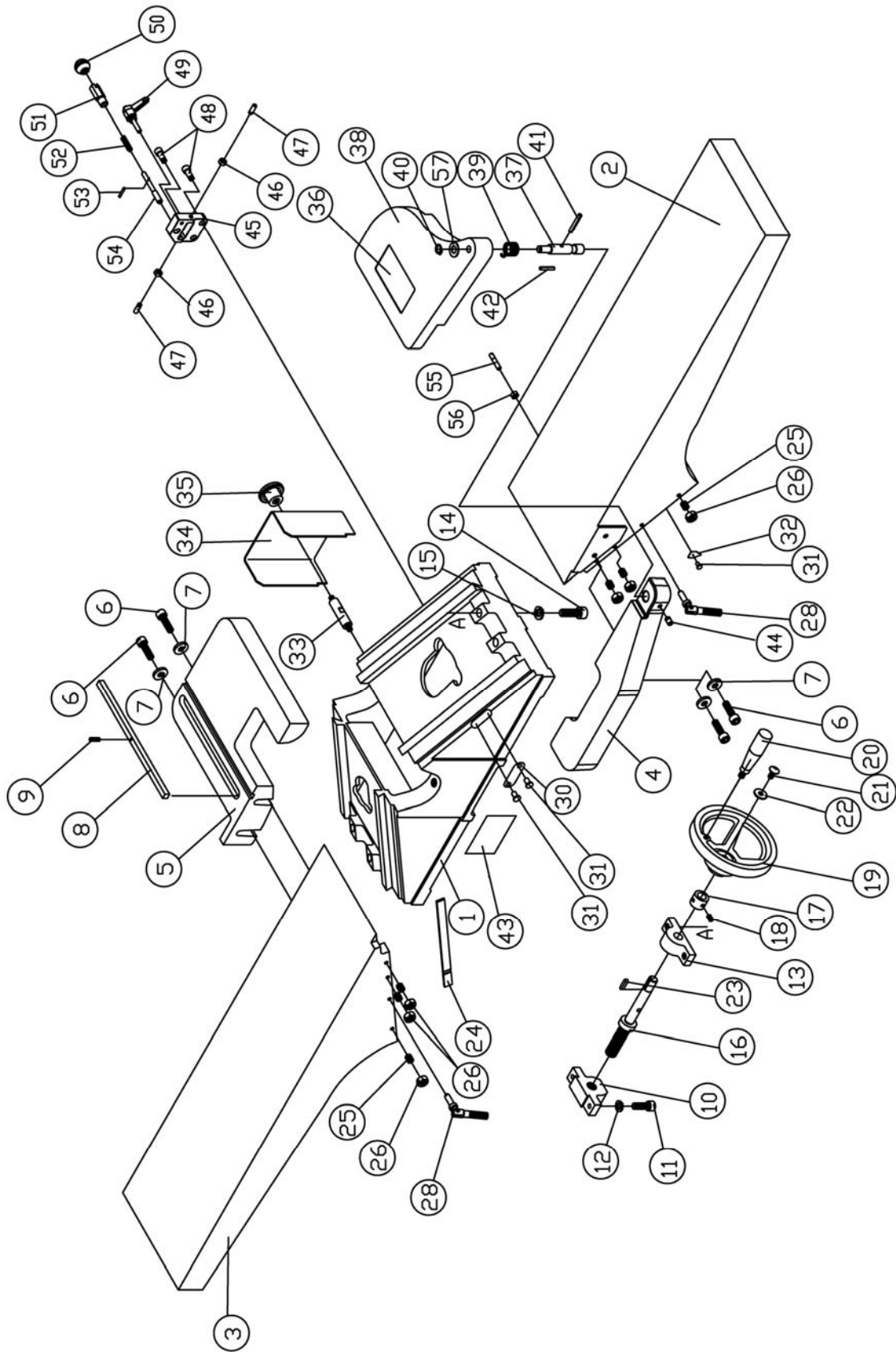

Parts List – Bed Assembly (all models)

Index No.	Part No.	Description	Size	Qty
1	JWJ8CS-201	Base		1
2	JWJ8CS-202	Front Table		1
3	JWJ8CS-203	Rear Table		1
4	JWJ8CS-204	Rabbeting Arm		1
5	JC-T05	Table Bracket		1
6	TS-0060051	Hex Cap Screw	3/8"-16 x 1"	4
7	JWJ8CS-207	Flat Washer	3/8" x 1" x 5/32"	4
8	JC-T07	Key	9.5 x 9.5 x 273	1
9	5F-E153	Spring Pin	4 x 16	1
10	JC-T08	Feed Screw Bracket		2
11	TS-0060061	Socket Head Cap Screw	3/8"-16 x 1-1/4"	4
12	TS-0720091	Lock Washer	3/8"	4
13	JC-T09	Bracket		2
14	JJ8HH-214	Cap Screw	1/2"-12 x 1-1/2"	4
15	TS-0720111	Lock Washer	1/2"	4
16	JC-T10	Feed Screw		2
17	JC-T11	Ring		2
18	TS-0267041	Set Screw	1/4"-20 x 3/8"	4
19	PA-C42	Handwheel		2
20	JC-T12	Handle		2
21	5C-D003	Pan Head Machine Screw	5/16"-18 x 1/2"	2
22	TS-0680031	Flat Washer	5/16"	2
23	F5-G107	Key	5 x 5 x 22	2
24	JC-T13	Gib		2
25	TS-0270091	Set Screw	5/16"-18 x 1"	6
26	TS-0561021	Hex Nut	5/16"-18	6
28	JWJ8CS-228	Lock Screw		2
30	JC-T16	Scale		1
31	5F-H051	Rivet		2
32	JC-T17	Depth Pointer		1
33	PA-C49	Guard Bolt		1
34	JC-T18	Pulley Cover		1
35	PA-C53	Nut		1
36	JC-T19	Warning Label		1
37	JC-T20	Guard Shaft		1
38	JC-T21	Cutterhead Guard		1
39	JC-T22	Spring		1
40	5F-A002	Retaining Ring	STW-11	1
41	5F-E208	Spring Pin	5 x 28	1
42	AP2-16	Spring Pin	6 x 28	1
43	LM000185	I.D. Label (JWJ-8CS)		1
	LM000186	I.D. Label (JWJ-8HH)		1
44	TS-0270051	Set Screw	5/16"-18 x 1/2"	1
45	JJ6CSDX-444	1/8" Set Block		1
46	TS-0561011	Hex Nut	1/4"-20	2
47	TS-0267071	Set Screw	1/4"-20 x 3/4"	2
48	TS-0208041	Hex Socket Cap Screw	5/16"-18 x 3/4"	2
49	5CO-D09B	Lock Handle		1
50	5DF-B05	Knob		1
51	JJ6CSDX-447	Stud		1
52	JEA-B08	Spring		1
53	PJ882-108	Spring Pin		1
54	JJ6CSDX-445	Stud		1
55	JJ6CSDX-460	Stud		1
56	TS-0561021	Hex Nut	5/16"-18	1
57	JWJ8CS-257	Flat Washer	1/2" x 1" x 1/16"	1

Stand and Motor Assembly (JWJ-8CS only)

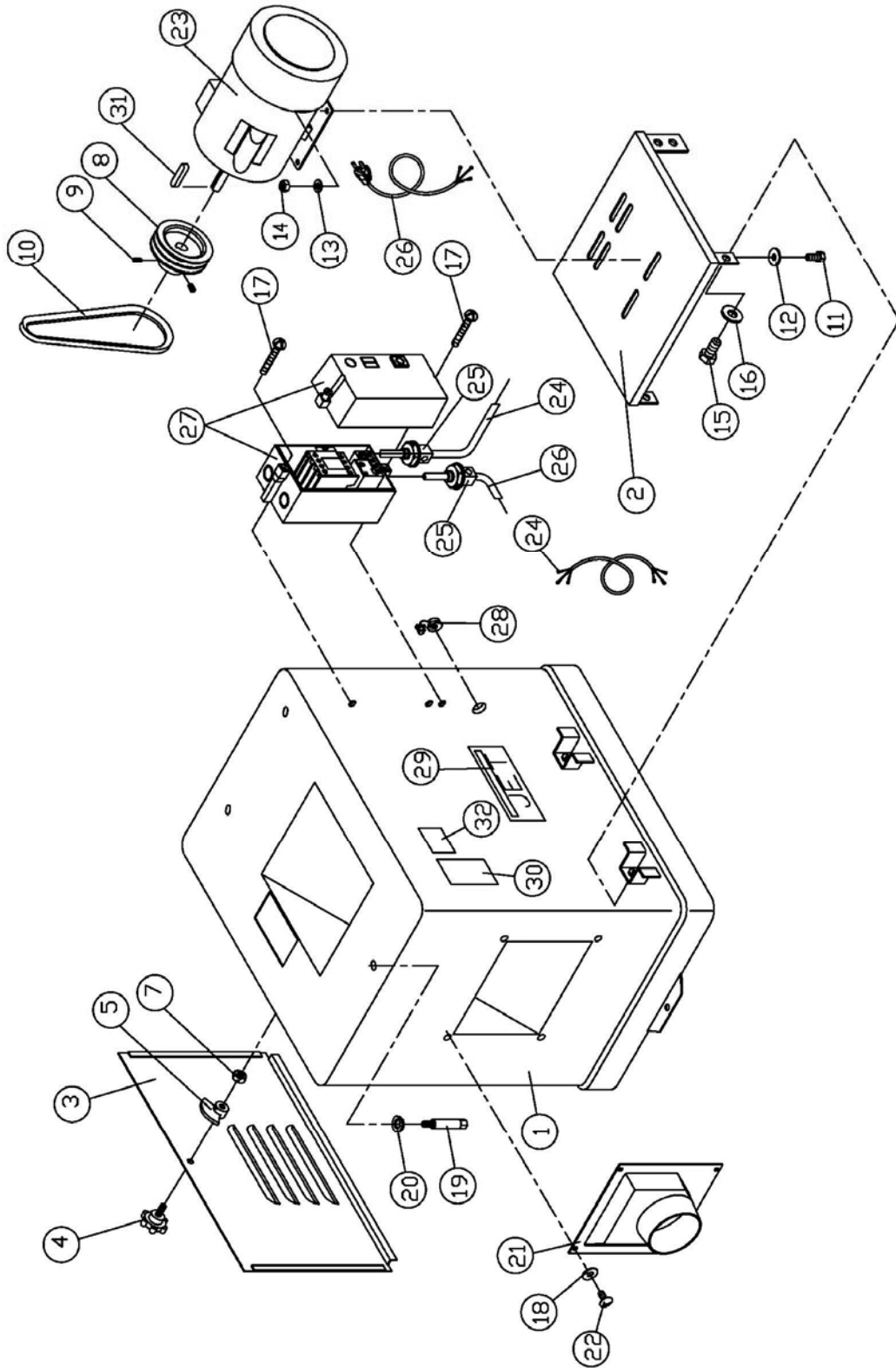

Parts List – Stand and Motor Assembly (JWJ-8CS only)

Index No.	Part No.	Description	Size	Qty
1	JC-M01W	Stand		1
2	JC-M02W	Motor Mount		1
3	JC-M03W	Cover		1
4	JC-M04	Screw		1
5	JC-M05	Key		1
7	TS-0561031	Hex Nut	3/8"-16	1
8	JC-M06	Motor Pulley		1
9	TS-0271071	Set Screw	3/8"-16 x 3/4"	2
10	VB-M52	V-Belt		2
11	TS-0081031	Hex Head Screw	5/16"-18 x 3/4"	4
12	TS-0680031	Flat Washer	5/16"	4
13	TS-0680031	Flat Washer	5/16"	4
14	TS-0561021	Hex Nut	5/16"-18	4
15	JJ8HH-315	Hex Head Screw	1/2"-12 x 1"	4
16	TS-0680061	Flat Washer	1/2"	4
17	JCS10-079C	Screw	3/16"-UNC x 3/4"	2
18	TS-0680021	Flat Washer	1/4"	4
19	JC-M07	Lock Bolt	3/8"-16	3
20	TS-0720091	Lock Washer	3/8"	3
21	JC-M03	Dust Chute		1
22	TS-0813032	Pan Head Screw	1/4"-20 x 1/2"	4
23	JJ8-917W	Motor	2HP, 1Ph	1
24	JJ8-918	Motor Cord		1
25	JJ8-919	Strain Relief		2
26	JJ8-920	Power Cord		1
27	JJ8CS-327	Switch		1
28	JJ8-923	Strain Relief		1
29	JET-138	JET Logo	5-7/16" x 2-1/4"	1
30	JC-T23	Warning Label		1
31	5FK-C13	Key	5x5x35	1
32	JJ6CSX-332	Warning Label – Depth Stop		1
	JJ8CS-HK	Hardware Kit (not shown)		

Stand and Motor Assembly (JWJ-8HH only)

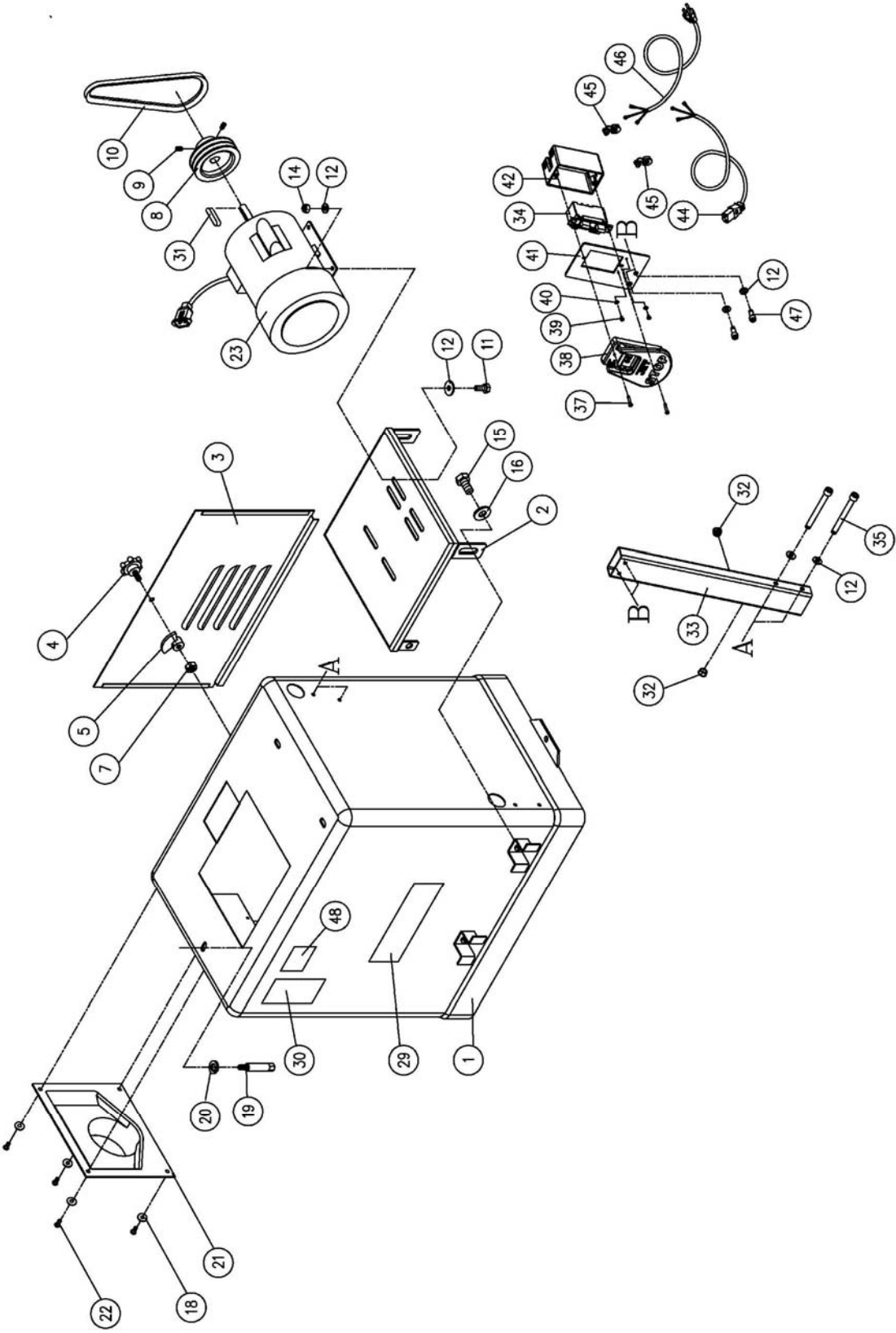

Parts List – Stand and Motor Assembly (JWJ-8HH only)

Index No.	Part No.	Description	Size	Qty
1	JJ8HH-301	Stand		1
2	JC-M02W	Motor Mount		1
3	JC-M03W	Cover		1
4	JC-M04	Knob Screw		1
5	JC-M05	Door Latch		1
7	TS-0561031	Hex Nut	3/8"-16	1
8	JC-M06	Motor Pulley		1
9	TS-0271031	Set Screw	3/8"-16x3/8"	2
10	VB-M52	V- Belt	M-52	2
11	TS-0081031	Hex Cap Screw	5/16"-18x3/4"	4
12	TS-0680031	Flat Washer	5/16"	12
14	TS-0561021	Hex Nut	5/16"-18	4
15	JJ8HH-315	Hex Bolt	1/2"-12x1"	4
16	TS-0680061	Flat Washer	1/2"	4
18	TS-0680021	Flat Washer	1/4"	4
19	JC-M07	Lock Bolt		3
20	TS-0720091	Lock Washer	3/8"	3
21	JC-M03	Dust Chute		1
22	TS-081F032	Screw	1/4"-20x1/2"	4
23	JJ8-917W	Motor	2HP, 1Ph	1
29	JET-138	JET Logo	5-7/16" x 2-1/4"	1
30	JC-T23	Warning Label		1
31	5FK-C13	Key	5x5x35	1
32	JJ6HH-316	Cord Protector		2
33	JJ6HH-315	Switch Arm		1
34	JPS10TS-343	Main Switch		1
35	TS-0208141	Socket Head Cap Screw	5/16"-18x3"	2
37	JJ6HH-348	Screw	M4x25	2
38	JPS10TS-342	Stop Switch Face Plate		1
39	TS-2171012	Screw	M4x6	2
40	JJ6HH-351	Star Washer	M4	2
41	JJ6HH-352	Switch Plate		1
42	JPS10TS-347	Switch Box		1
44	JJ8HH-344	Motor Cord		1
45	JJ8HH-345	Strain Relief		2
46	JJ8HH-346	Power Cord		1
47	TS-0208021	Socket Head Cap Screw	5/16"-18x1/2"	2
48	JJ6CSX-332	Warning Label – Depth Stop		1
	JJ8HH-HK	Hardware Kit (not shown)		1

Parts List – Cutterhead Assembly (JWJ-8CS only)

Index No.	Part No.	Description	Size	Qty
1	JC-C01	Cutterhead		1
2	JC-C02	Bearing Housing		2
3	5H-A104	Bearing		2
4	JC-C03	Cutterhead Set Bolt		2
5	TS-0680041	Flat Washer	3/8"	2
6	TS-0561031	Nut	3/8"-16	2
7	PA-C05	Spring		6
8	708802	Knife		3
9	JC-C05	Knife Lock Bar		3
10	JC-C06	Screw		15
11	JC-C07	Knife Gauge Rod		1
12	JC-C08	Knife Gauge		2
13	JJ8-0013	Retaining Ring	STW-9"	4
15	JC-C09	Machine Pulley		1
16	5F-G107	Key	5 x 5 x 22	1
17	TS-0270031	Set Screw	5/16"-18NC x 3/8"	2

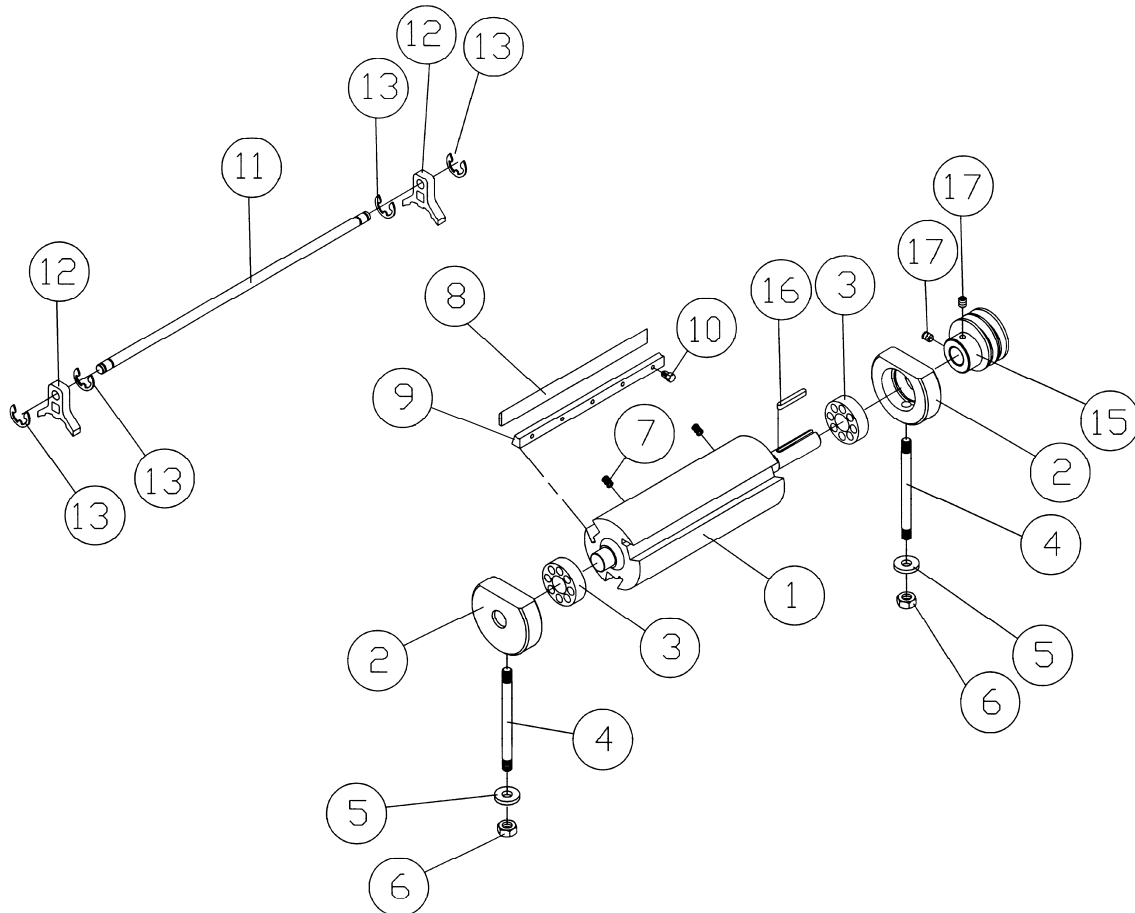

Parts List – Cutterhead Assembly (JWJ-8HH only)

Index No.	Part No.	Description	Size	Qty
.....	JJ8HH-CA	Cutterhead Assembly (Index # 1 thru 11)	1
.....	1791222-4	Helical Cutterhead Unit (Index # 1, 7, 8)	1
1	JJ8HH-101	Helical Cutterhead	1
2	JC-C02	Bearing Housing	2
3	BB-6204VV	Ball Bearing	6204VV	2
4	JC-C03	Bolt	2
5	TS-0680041	Flat Washer	3/8"	2
6	TS-0561031	Hex Nut	3/8"-16	2
7	1791212	Knife Insert (set of 10)	total 36
8	JWP208HH-111	Knife Insert Screw	#10-32x1/2	36
9	5F-G107	Key	5x5x22	1
10	TS-0270031	Socket Set Screw	5/16"-18x3/8"	2
11	JC-C09	Cutterhead Pulley	1
12	JJ6HH-113	Star Point Screwdriver (not shown)	2

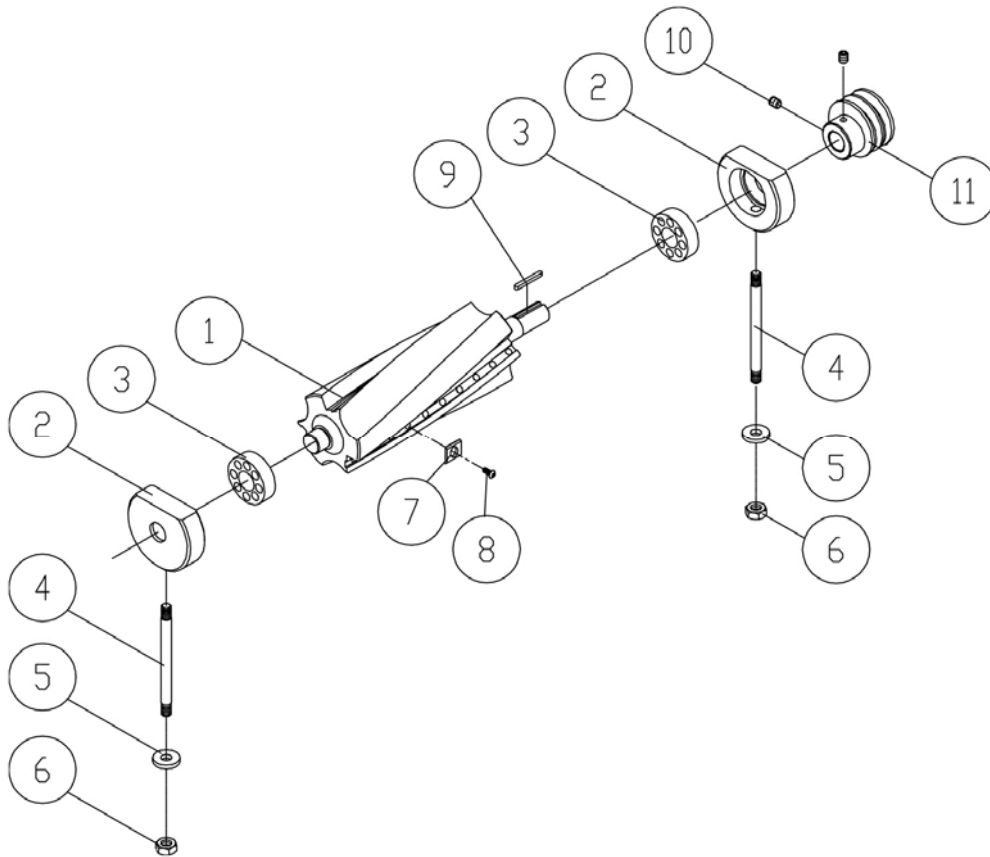

Electrical Connections (JWJ-8CS only)

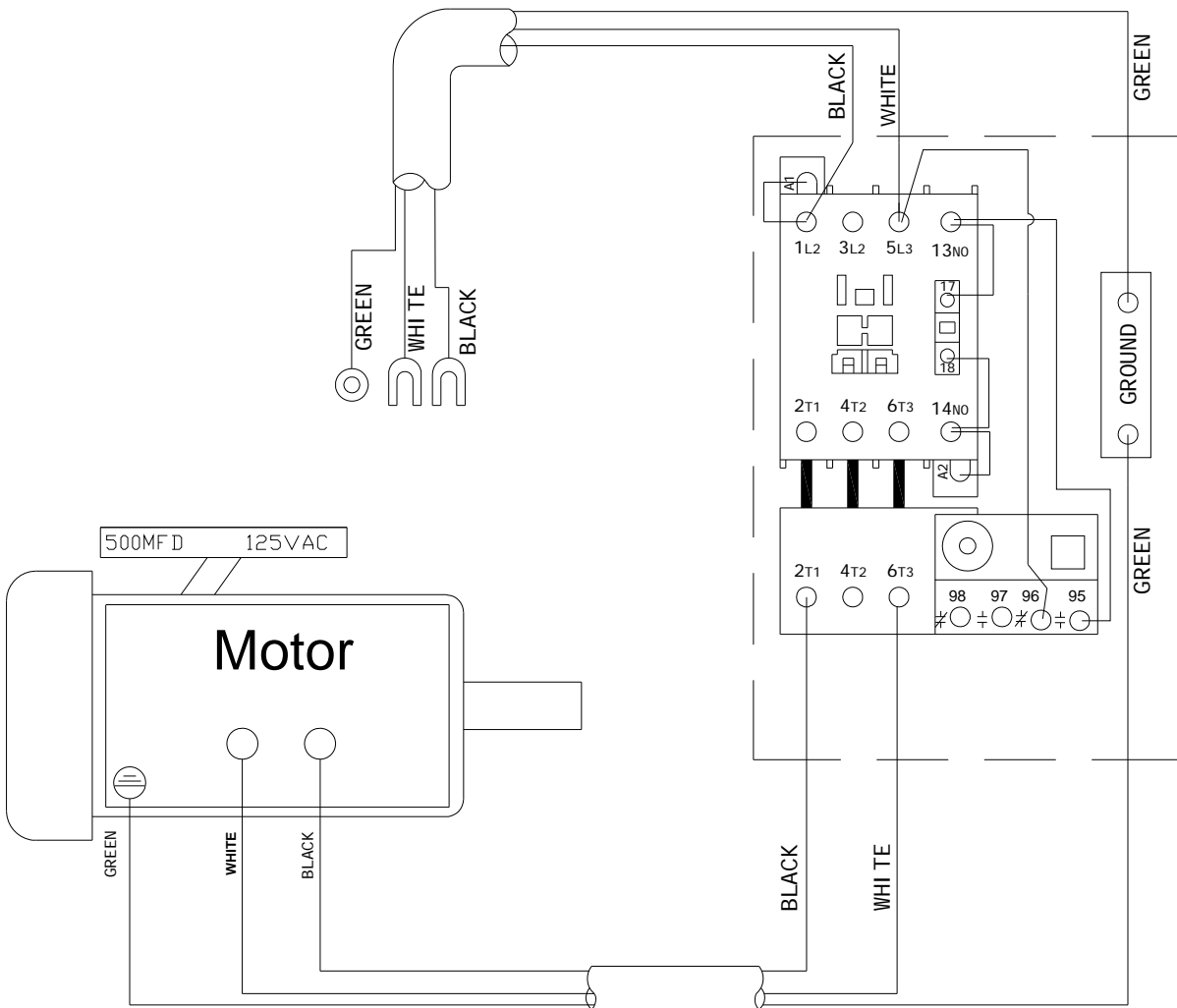

Electrical Connections (JWJ-8HH only)

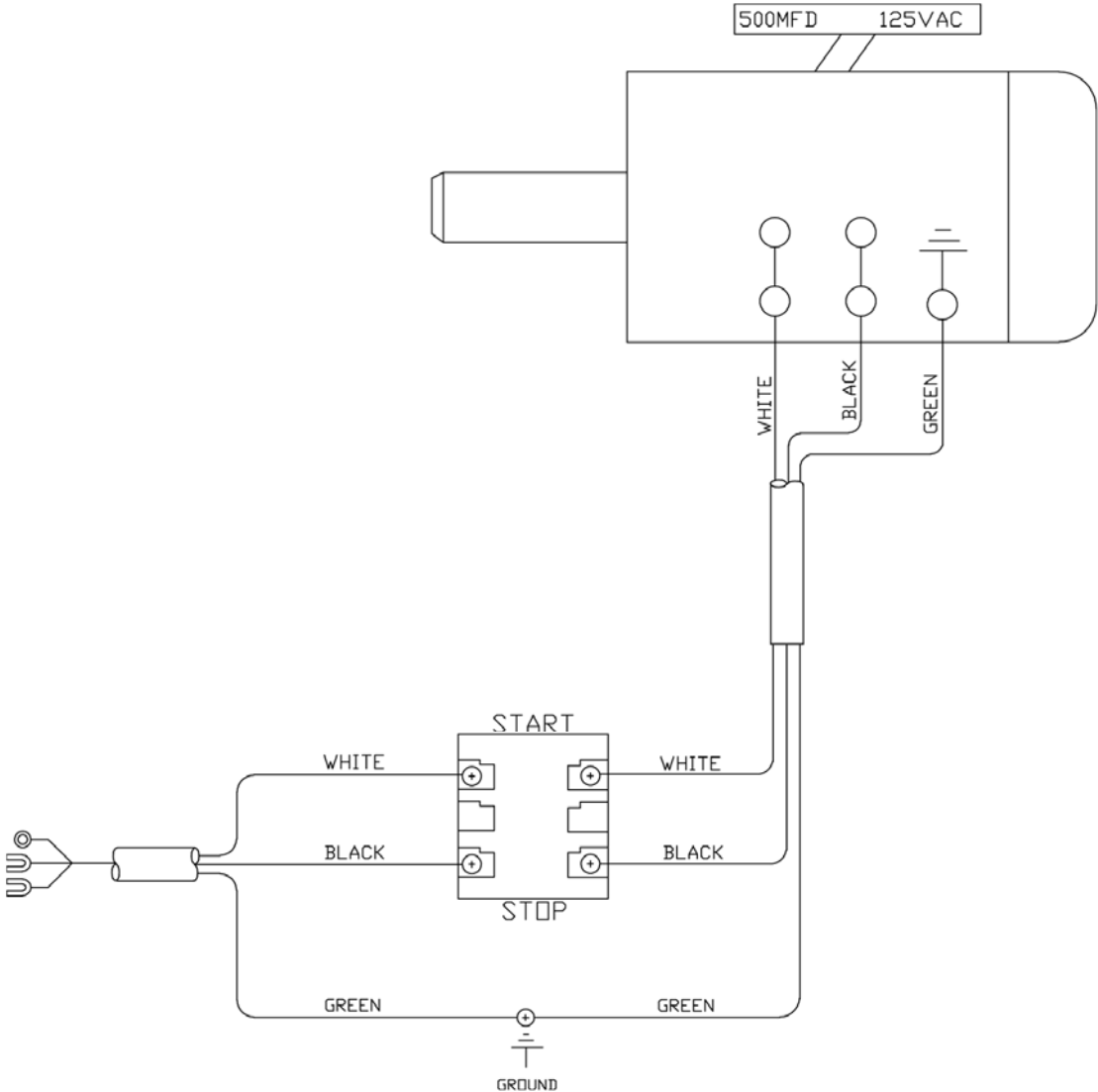



427 New Sanford Road
LaVergne, Tennessee 37086
Phone: 800-274-6848
www.jettools.com