



# Operating Instructions and Parts Manual Belt and Disc Sanding Machine

Model J-4210



**JET**  
427 New Sanford Road  
LaVergne, Tennessee 37086  
Ph.: 800-274-6848  
[www.jettools.com](http://www.jettools.com)

**Part No. M-414550**  
Revision C 10/2018  
Copyright © 2014 JET



# 1.0 IMPORTANT SAFETY INSTRUCTIONS

## WARNING – To reduce risk of injury:

- Misuse of this machine can cause serious injury.
- For safety, the machine must be set up, used and serviced properly.
- Read, understand and follow the instructions in the operator's and parts manual which was shipped with your machine.
- Never modify the machine without consulting JET.

## 1.1 General Machinery Warnings

1. Always wear protective eye wear when operating machinery. Eye wear shall be impact resistant, protective safety glasses with side shields which comply with ANSI Z87.1 specifications. Use of eye wear which does not comply with ANSI Z87.1 specifications could result in severe injury from the breakage of the eye protection.
2. Wear proper apparel. No loose clothing or jewelry which can get caught in moving parts. Rubber soled, nonslip, footwear is recommended for best footing.
3. Do not overreach. Failure to maintain a proper working position can cause you to fall into the machine or cause your clothing to get caught — pulling you into the machine.
4. Keep guards in place and in proper working order. Do not operate the machine with the guards removed.
5. Avoid dangerous working environments. Do not use stationary machine tools in wet or damp locations. Keep work areas clean and well lit.
6. Avoid accidental starts by being sure that the start switch is in the "OFF" position before plugging in the machine.
7. Never leave the machine running while unattended. The machine shall be shut off whenever it is not being used.
8. Disconnect the electrical power before servicing, whenever changing accessories or when general maintenance is done on the machine.
9. Maintain all machine tools with care. Follow all maintenance instructions for lubricating and the changing of accessories. No attempt shall be made to modify or have makeshift repairs done to the machine. This not only voids the warranty but also renders the machine unsafe.
10. If there is any risk of tipping or sliding, the machinery must be anchored to the floor.
11. Secure your work. Use clamps or a vise to hold your work, when practical. It is safer than using your hands and it frees both hands to operate the machine.
12. Never brush chips away while the machine is in operation.
13. Keep work area clean. Cluttered areas invite accidents.
14. Remove adjusting keys and wrenches before turning the machine on.
15. Use the right tool. Don't force a tool or attachment to do a job for which it was not designed.
16. Use only recommended accessories and follow manufacturer's instructions pertaining to them.
17. Keep hands in sight and clear of all moving parts and cutting surfaces.
18. All visitors should be kept at a safe distance from the work area. Make your workshop completely safe by using padlocks, master switches, or by removing starter keys.
19. Know the tool you are using; its application, limitations, and potential hazards.
20. Do not stand on the tool. Serious injury could occur if the tool is tipped or the cutting tool is unintentionally contacted.
21. Check damaged parts. Before further use of the tool, a guard or other part that is damaged should be carefully checked to determine that it will operate properly and perform its intended function- check for alignment of moving parts, binding of moving parts, breakage of parts, mounting, and any other conditions that may affect its operation. A guard or other part that is damaged should be properly repaired or replaced.

## 1.2 General Electrical Cautions

This machine must be grounded in accordance with the National Electrical Code and local codes and ordinances. The work should be done by a qualified electrician. The machine must be grounded to protect the user from electrical shock.



**CAUTION:** For circuits that are a great distance from the electrical service box, the wire size must be increased in order to deliver ample voltage to the motor. To minimize power losses and to prevent motor overheating and burnout, the use of wire sizes for branch circuits or electrical extension cords according to the following table is recommended:

Conductor length	AWG (American Wire Gauge) number	
	240 volt lines	120 volt lines
0-50 feet	No. 14	No. 14
50-100 feet	No. 14	No. 12
Over 100 feet	No. 12	No. 8

### 1.3 Safety Requirements for Abrasive Sanding Machines

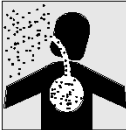
Abrasive sanding can be hazardous to operators and bystanders. Sanding sparks, chips and dust particles thrown off by the sanding disc can cause serious injury by contact or inhalation. To avoid injuries you must comply with the following safety requirements:

1. Always wear protective eyewear when operating machinery. Eye wear shall be impact resistant, protective safety glasses with side shields which comply with ANSI Z87.1. Use of eye wear which does not comply with ANSI Z87.1 specifications could result in severe injury from breakage of eye protection. 
2. Wear leather safety gloves, arm guards, leather aprons and safety shoes.
3. A dust collection system is recommended, Operator shall also wear a dust mask at all times. 
4. Additional precautions may be necessary for sanding materials which are flammable or have other hazardous properties. You should always consult the manufacturer of such materials for instructions on sanding and handling.
5. Do not force or jamb the workpiece into the sanding disc.
6. Before sanding, always allow the motor to come up to operating speed, then check the sanding disc for wobble, runout, or any unbalanced condition. If the disc is not operating accurately and smoothly, immediately stop the motor and make repairs before attempting any sanding operations.

7. Abrasive discs must be stored in a controlled environment area. Relative humidity should be 35% to 50% and the temperature should be between 60 and 80 degrees Fahrenheit. Failure to do so could cause premature disc failure.
8. Examine the face of the sanding disc carefully. Excessive sanding which wears down to the backing material can tearing of the disc. Never use a disc which shows backing, nicks or cuts on the surface or edge or damage due to creasing or poor handling.
9. When installing a new disc, be certain the disc is accurately centered on the drive wheel. Failure to do so could cause a serious unbalanced condition.
10. Always present the workpiece to the wheel while resting the workpiece firmly on the table. Failure to do so could result in damage to the workpiece or throwing of the workpiece off the wheel. 
11. Safety shoes which comply with ANSI Z41.1 shall be worn. 
12. Personal hearing protection such as ear plugs or ear muffs shall be used to protect against the effect of noise exposure.

**⚠ WARNING:** This product can expose you to chemicals including lead and cadmium which are known to the State of California to cause cancer and birth defects or other reproductive harm, and phthalates which are known to the State of California to cause birth defects or other reproductive harm. For more information go to <http://www.p65warnings.ca.gov>.

**⚠ WARNING:** Some dust, fumes and gases created by power sanding, sawing, grinding, drilling, welding and other construction activities contain chemicals known to the State of California to cause cancer and birth defects or other reproductive harm. Some examples of these chemicals are:

- lead from lead based paint
- crystalline silica from bricks, cement and other masonry products
- arsenic and chromium from chemically treated lumber

Your risk of exposure varies, depending on how often you do this type of work. To reduce your exposure to these chemicals, work in a well-ventilated area and work with approved safety equipment, such as dust masks that are specifically designed to filter out microscopic particles. For more information go to <http://www.p65warnings.ca.gov/> and <http://www.p65warnings.ca.gov/wood>.

## SAVE THESE INSTRUCTIONS

Familiarize yourself with the following safety notices used in this manual:



This means that if precautions are not heeded, it may result in minor injury and/or possible machine damage.



This means that if precautions are not heeded, it may result in serious, or possibly even fatal, injury.

## 2.0 Table of contents

Section	Page
1.0 IMPORTANT SAFETY INSTRUCTIONS .....	2
1.1 General Machinery Warnings .....	2
1.2 General Electrical Cautions .....	2
1.3 Safety Requirements for Abrasive Sanding Machines .....	3
2.0 Table of contents .....	4
3.0 About this manual .....	5
4.0 About the J-4210 Sander .....	5
5.0 Features .....	5
6.0 Specifications .....	6
7.0 Setup and assembly .....	7
8.0 Electrical connections .....	7
8.1 Grounding Instructions .....	7
8.2 Voltage conversion .....	8
9.0 Adjustments .....	8
9.1 Adjusting belt tracking .....	8
9.2 Platen housing position .....	8
9.3 Adjusting sander tables .....	8
10.0 Operation .....	9
10.1 Miter gauge .....	9
10.2 Controls .....	9
11.0 User-maintenance .....	9
11.1 Lubrication .....	9
11.2 Cleaning .....	9
11.3 Replacing sanding belt .....	9
11.4 Replacing sanding disc .....	10
11.5 Replacing V-belts .....	10
11.6 Replacing motor .....	11
11.7 Additional servicing .....	11
12.0 Troubleshooting J-4210 Belt-Disc Sander .....	12
13.0 Replacement Parts .....	12
13.1.1 J-4210 Belt & Disc Sander – Exploded View .....	13
13.1.2 J-4210 Belt & Disc Sander – Parts List .....	14
13.2.1 J-4210 Stand – Exploded View .....	16
13.2.2 J-4210 Stand – Parts List .....	16
14.0 Electrical Connections for J-4210 .....	17
15.0 Warranty and service .....	18

### 3.0 About this manual

This manual is provided by JET, covering the safe operation and maintenance procedures for the J-4210 Belt and Disc Sander. This manual contains instructions on installation, safety precautions, general operating procedures, maintenance instructions and parts breakdown. Your machine has been designed and constructed to provide consistent, long-term operation if used in accordance with the instructions set forth in this document.

If there are questions or comments, please contact your local supplier or JET. JET can also be reached at our web site: [www.jettools.com](http://www.jettools.com).

Retain this manual for future reference. If the machine transfers ownership, the manual should accompany it.

**⚠WARNING** Read and understand the entire contents of this manual before attempting assembly or operation! Failure to comply may cause serious injury!

Register your product online - <http://www.jettools.com/us/en/service-and-support/warranty/registration/>

### 4.0 About the J-4210 Sander

The JET Model J-4210 Belt and Disc Sanding Machine is ideal for all shops. This versatile machine can be used to grind, sand, finish, and contour all types of parts including metal, wood, plastic, and composite materials. Because of these capabilities, the JET sander eliminates the need for multiple machines to perform the same tasks.

### 5.0 Features

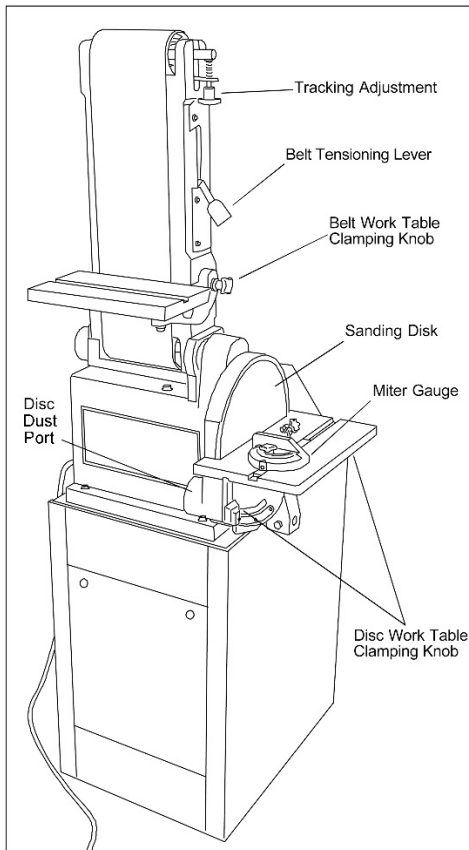

Figure 1

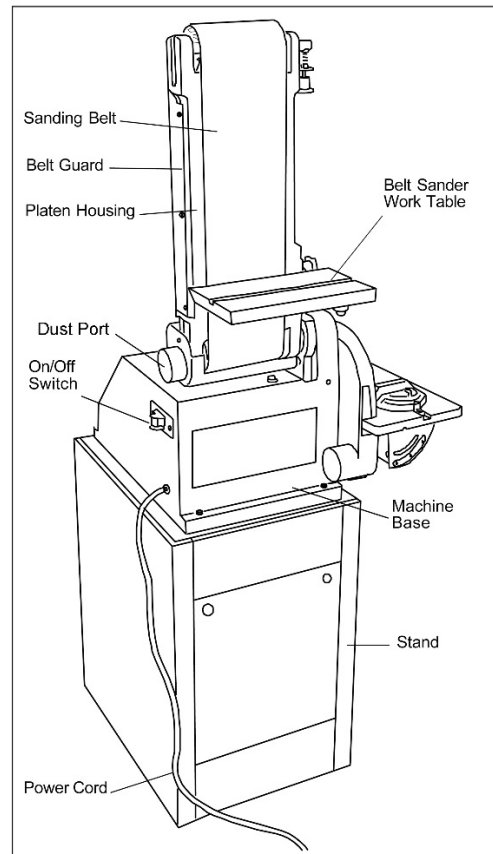

Figure 2

## 6.0 Specifications

Model number		<b>J-4210</b>
Stock numbers	Belt/Disc Sander with Stand	<b>414550K</b>
	Belt/Disc Sander only	<b>414550</b>
	Stand only	<b>414549</b>
<b>Motor and Electricals</b>		
Motor type		Totally enclosed, fan cooled
Horsepower		1 HP
Motor phase		single
Motor voltage		115/230 V
Cycle		60 Hz
Full load amperage (FLA)		10 / 5.5
Motor speed		3450 RPM
Power transfer		v-belt
On/off switch		Pushbutton with removable safety key
Recommended circuit size <sup>1</sup>		15 A
<b>Belt sanding</b>		
Belt speed		1650 SFPM
Belt size and grit		6 x 48 in. (153 x 1219 mm), 80 Grit
Dust port, outside diameter		2-1/2 in. (63.5 mm)
Platen		Cast iron
Belt table		Cast iron, 6 x 10-1/2 in. (153 x 267 mm)
Belt table miter slot		5/8 in. (16 mm)
<b>Disc sanding</b>		
Disc speed		2100 RPM
Abrasive disc size and grit		10 in. (254 mm), 80 Grit
Disc table		Cast iron, 7-1/2 x 13 in. (191 x 330 mm)
Disc table miter slot		5/8 in. (16 mm)
Disc table tilt		45 deg. out
Dust port, outside diameter		2-1/2 in. (63.5 mm)
<b>Dimensions</b>		
Overall dimensions, Sander and Stand (LxWxH)		23 x 26 x 61 in. (584 x 660 x 1550 mm)
<b>Weights</b>		
Net weight (sander and stand)		170 lbs. (77 kg)
Shipping weight	Sander only	121 lbs. (55 kg)
	Stand only	55 lbs. (25 kg)

Table 1

L = length, W = width, H = height

RPM = revolutions per minute

SFPM = surface feet per minute

<sup>1</sup> Subject to local/national electrical codes.

The specifications in this manual were current at time of publication, but because of our policy of continuous improvement, JET reserves the right to change specifications at any time and without prior notice, without incurring obligations.

**⚠WARNING** Read and understand all assembly instructions before attempting assembly. Failure to comply may cause serious injury.

## 7.0 Setup and assembly

It is recommended that the belt and disc sander be secured to the floor for safe operation. The machine stand has mounting holes in a flange on the inside of stand enclosure. The stand can be secured to the floor using these mounting holes.

## 8.0 Electrical connections

The J-4210 Belt/Disc Sander is rated at 115/230V power, and is pre-wired for 115 volt.

Before connecting to power source, be sure switch is in *off* position.

It is recommended that the sander be connected to a dedicated 15 amp circuit with circuit breaker or fuse. If connected to a circuit protected by fuses, use time delay fuse marked "D". **Local codes take precedence over recommendations.**

### 8.1 Grounding Instructions

#### 1. All Grounded, Cord-connected Tools:

In the event of a malfunction or breakdown, grounding provides a path of least resistance for electric current to reduce the risk of electric shock. This tool is equipped with an electric cord having an equipment-grounding conductor and a grounding plug. The plug must be plugged into a matching outlet that is properly installed and grounded in accordance with all local codes and ordinances.

Do not modify the plug provided - if it will not fit the outlet, have the proper outlet installed by a qualified electrician.

Improper connection of the equipment-grounding conductor can result in a risk of electric shock. The conductor with insulation having an outer surface that is green with or without yellow stripes is the equipment-grounding conductor. If repair or replacement of the electric cord or plug is necessary, do not connect the equipment-grounding conductor to a live terminal.

**⚠WARNING** Check with a qualified electrician or service personnel if the grounding instructions are not completely understood, or if in doubt as to whether the tool is properly grounded. Failure to comply may cause serious or fatal injury.

Use only 3-wire extension cords that have 3-prong grounding plugs and 3-pole receptacles that accept the tool's plug.

Repair or replace damaged or worn cord immediately.

#### 2. Grounded, cord-connected tools intended for use on a supply circuit having a nominal rating **less than 150 volts**:

This tool is intended for use on a circuit that has an outlet that looks like the one illustrated in **A**, Figure 3. An adapter, shown in **B** and **C**, may be used to connect this plug to a 2-pole receptacle as shown in **B** if a properly grounded outlet is not available. The temporary adapter should be used only until a properly grounded outlet can be installed by a qualified electrician. *This adapter is not permitted in Canada.* The green-colored rigid ear, lug, and the like, extending from the adapter must be connected to a permanent ground such as a properly grounded outlet box.

#### 3. Grounded, cord-connected tools intended for use on a supply circuit having a nominal rating **between 150 - 250 volts, inclusive**:

This tool is intended for use on a circuit that has an outlet that looks like the one illustrated in **D**, Figure 3. The tool has a grounding plug that looks like the plug illustrated in **D**. Make sure the tool is connected to an outlet having the same configuration as the plug. No adapter is available or should be used with this tool. If the tool must be reconnected for use on a different type of electric circuit, the reconnection should be made by qualified service personnel; and after reconnection, the tool should comply with all local codes and ordinances.

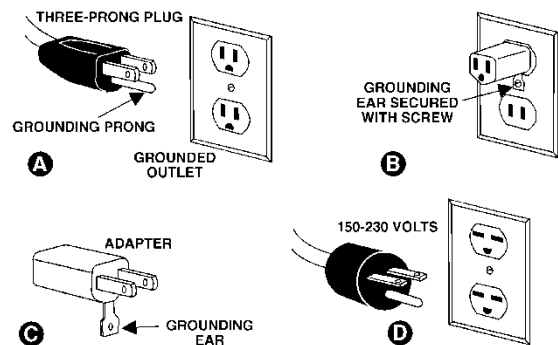

Figure 3

#### 4. Permanently connected tools:

This tool should be connected to a grounded metal permanent wiring system; or to a system having an equipment-grounding conductor.

5. Polarized plugs – To reduce the risk of electric shock, this equipment has a polarized plug (one blade is wider than the other). This plug will fit in a polarized outlet only one way. If the plug does not fit fully in the outlet, reverse the plug. If it still does not fit, contact a qualified electrician to install the proper outlet. Do not change the plug in any way.

## 8.2 Voltage conversion

Disconnect machine from power source.

To switch the incoming power leads for 230 volt operation, follow wiring diagram on inside cover of motor junction box. A similar diagram is found in *sect. 14.0* of this manual. (Note: In case of discrepancy, diagram on machine takes precedence.)

If using an electrical plug, the plug on the end of the motor cord must be replaced with a UL/CSA listed plug rated for 240V power.

## 9.0 Adjustments

### 9.1 Adjusting belt tracking

The tracking of the sanding belt may require adjustment after changing the belt. The belt housing has a tracking adjustment mechanism for this purpose (Figure 4).

1. Start the machine.
2. Check tracking of sanding belt; the belt should track at center of drums.
3. Adjust belt tracking by turning the adjustment knob as needed. Do this in small increments and allow belt to respond to the changes.

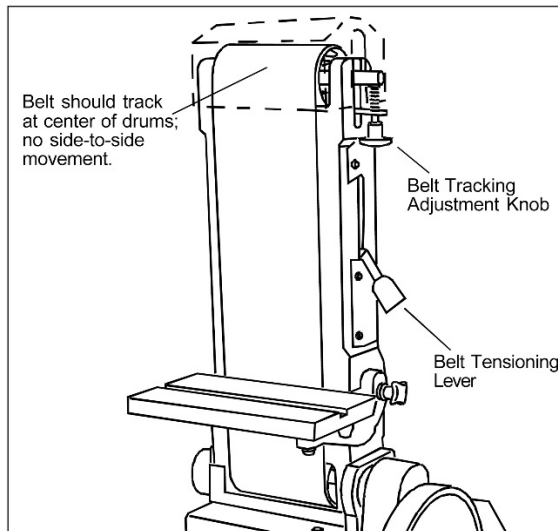

Figure 4: belt tracking adjustment

### 9.2 Platen housing position

The sanding belt can be operated with the platen housing at horizontal, vertical, or any angle in between. Change position of platen housing as follows. (Numbers in parentheses correspond to index numbers in parts list, *sect. 13.1.1*)

1. Disconnect electrical power.
2. Remove four screws (52) and pulley cover (12).
3. Using an open end wrench, loosen two hex screws (13) (also refer to Figure 5).

4. Move platen housing to desired position. When platen housing is to be placed in horizontal position, lower platen housing onto stop screw (28) on machine base.
5. If the stop requires adjustment, loosen jam nut (29), adjust stop screw (28) to desired position, and tighten nut (29).
6. Tighten two hex screws (13).
7. Install pulley cover (12) and secure with four screws (52).
8. Start the machine to check operation.

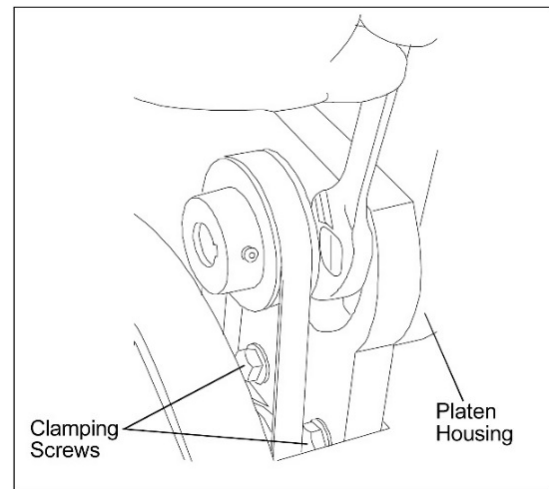

Figure 5: platen housing clamping screws

### 9.3 Adjusting sander tables

#### 9.3.1 Disc table

1. To change the disc table angle, loosen clamping knob on left side of table (refer to Figure 6).
2. Move table to desired angle.
3. Tighten clamping knob to secure table.

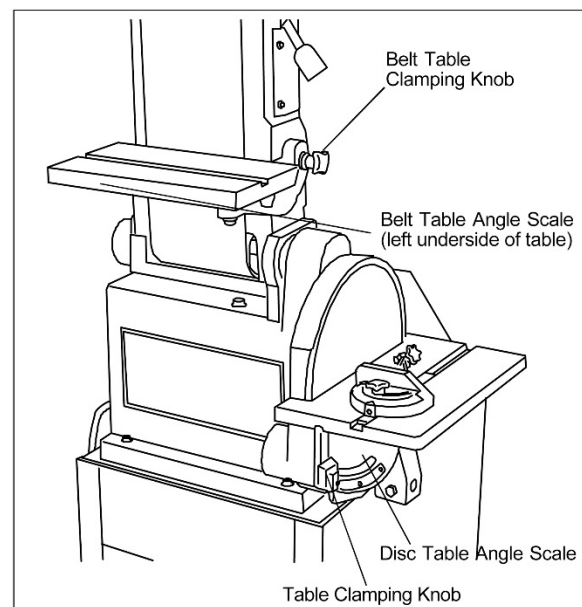

Figure 6: sander table angle



### 9.3.2 Belt table

1. To change belt table angle, loosen clamping knob on right side of platen housing (refer to Figure 6).
2. Move table to desired angle.
3. Tighten knob to secure table.

## 10.0 Operation

This section defines the controls and other features with which the operator should be familiar. Refer to Figures 7 and 8 for some typical sander operations.

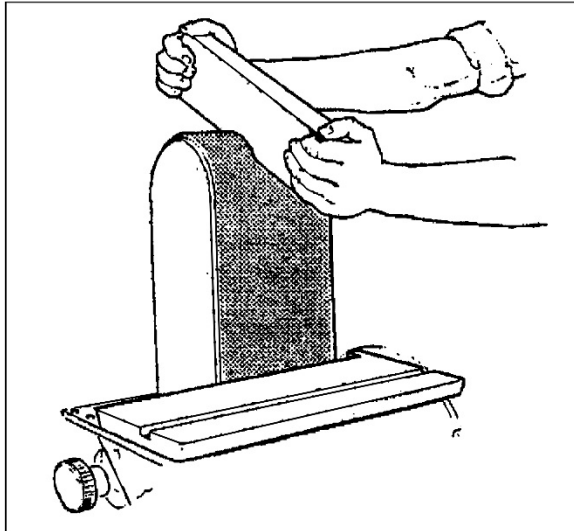

Figure 7: contouring with belt sander

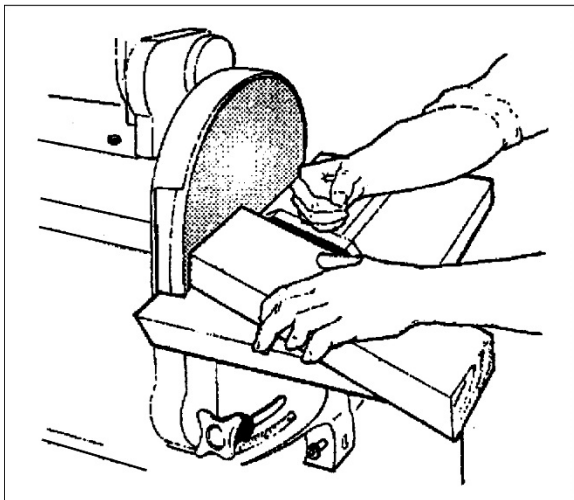

Figure 8: bevel sanding with miter gauge

### 10.1 Miter gauge

A miter gauge is provided with the machine and can be used on either belt sander or disc sander work tables. The angle of miter gauge can be adjusted up to 45 degrees to accommodate angular work piece surfaces.

## 10.2 Controls

The on/off switch is located on the side of the machine base. It has a safety key to prevent unauthorized use of the machine. Turn off sander, pull out safety key, and store key in a safe place. Key must be reinserted to start machine.

## 11.0 User-maintenance

**⚠WARNING** Always disconnect power to machine before performing maintenance. Failure to do this may result in serious personal injury.

Numbers in parentheses correspond to index numbers in parts list, sect. 13.1.1.

### 11.1 Lubrication

The bearings used in the sander are pre-lubricated and sealed. The bearings do not require periodic lubrication.

### 11.2 Cleaning

Periodically use a vacuum cleaner to remove sanding debris from the machine. In hard to reach areas, brush the debris loose while vacuuming.

### 11.3 Replacing sanding belt

1. Disconnect electrical power.
2. Position sanding belt platen (4) in vertical position. Remove eight screws (97) and guard (96).
3. Remove screw (76) and guard (75).
4. Move tensioning lever (50) downward to slacken sanding belt (79).
5. Slip sanding belt off drums (5) and (39). Also refer to Figure 9.

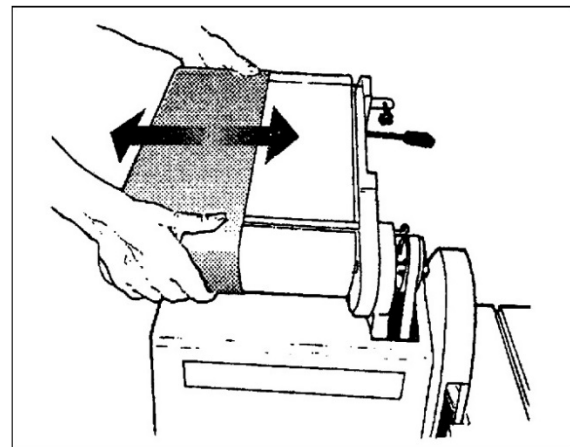

Figure 9: sanding belt removal

6. Install replacement sanding belt on drums.
7. Position edges of sanding belt evenly on the drums.

8. Lift tensioning lever to tighten sanding belt on drums.
9. Install guard (75) and secure with screw (76).
10. Install guard (96) and secure with eight screws (97).
11. Connect electrical power and operate machine to check operation.
12. If belt does not track properly, adjust tracking (sect. 9.1).

#### 11.4 Replacing sanding disc

1. Disconnect electrical power.
2. Loosen screw (65). Remove disc table (60).
3. Remove four screws (56) and plate (55) from disc shroud (53).
4. Insert a long T-handle Allen wrench through side opening in shroud (53) and into set screw (57). Loosen disc set screw (57) and remove disc (58).

**⚠WARNING** Use care when using knife to separate sanding disc (59) from machine disc (58). Injury from the knife may occur if the knife slips or if sanding disc should suddenly come free.

5. Using a knife, slowly work tip of knife blade under sanding disc (59). Slowly work tip around circumference of disc (58). Continue to work around the circumference until sanding disc can be separated by hand from disc (58).
6. Remove paper backing from replacement sanding disc (59). Place sanding disc (59) on machine disc (58). Make sure sanding disc is placed evenly at outside diameter of disc (58).
7. Press on sanding disc to remove any entrapped air and to make sure sanding disc is adhering to disc (58).
8. Install disc (58) onto shaft (16). Position disc on the shaft to provide clearance between plate (55) and sanding disc. Tighten set screw (57).

**NOTE:** There is a close fit between edge of disc (58) and disc shroud. To ease installation and positioning of disc, use an L-shaped tool (such as an Allen wrench) under outer edge of disc to support and position the disc while tightening set screw.

9. Install plate (55) and secure with four screws (56). Check for clearance between plate (55) and sanding disc.
10. Install table (60) onto rod (74). Position table so it is level and tighten screw (65) against rod (74).
11. Connect electrical power and operate machine to check operation.

#### 11.5 Replacing V-belts

1. Disconnect electrical power.
2. Remove sanding belt table.
3. Remove sanding disc table.
4. Remove sanding disc and shroud.
5. Remove pulley cover. Loosen set screw in pulley.
6. With second person holding belt housing, alternately loosen and remove two screws.
7. Remove V-belt from pulley (11). Remove pulley from shaft while separating assembled belt housing from machine base.
8. Remove key from sanding belt drum shaft.
9. Loosen set screw in pulley (20).
10. Remove pulley. While removing pulley, slip V-belts from pulley.
11. Remove four screws from base. With assistance of a second person, lift base from stand.

**NOTE:** Place base on bench. As an alternative, the stand may be used to support the base while removing drive motor screws.

12. Place base on bench with underside of base facing up.
13. Remove two hex head screws, two nuts, and two washers from motor base on shaft side of motor.
14. Loosen (but do not remove) two hex bolts, two nuts, and two washers on the side of motor base opposite motor shaft.
15. Tip motor enough to provide clearance between end of shaft and wall of base. Remove motor drive belt.
16. With base still on the bench, slip V-belt (15) over end of idler shaft.

**NOTE:** Install V-belt for sanding belt first, followed by motor V-belt.

17. Install replacement V-belt over end of motor shaft.
18. Install two hex bolts, two nuts, and two washers in the motor base on the shaft side of motor. Tighten all four hex nuts and hex head screws.
19. Install key in idler shaft with keyway facing up. Install pulley (20) on idler shaft.
20. Install motor V-belt (18) in outermost groove of pulley (20) and on pulley (18) on motor shaft.
21. Position motor belt (18) on idler shaft so it is parallel with inner wall of base. Tighten set screw in pulley (20).
22. Place assembled base on stand. Secure with four screws, washers, nuts.

**NOTE:** Because of the weight of the belt housing, a second person should hold belt housing in position while installing pulley (10).

23. Hold belt housing in position in bracket (3). Start two screws (13) in threaded holes in platen. Install key (8) in shaft.

**NOTE:** Because of the length of screws (13), the screws will have to be installed alternately. As screws are installed, there will be enough clearance to slide belt drum drive pulley a little at a time onto shaft (8).

24. Alternately install two screws (13). As the screws are tightened, slide pulley (10) onto idler shaft as allowed by the protrusion of screw heads. Make sure V-belt remains on pulleys (11 and 20).
25. When screws (13) are fully installed, align pulley (20) with pulley (11). Tighten set screw (10).
26. Install shroud (53) on base and secure with four screws and washers.
27. Install pulley cover (12) and secure with two screws.
28. Install disc (58) onto shaft (16) and over key. Position disc on shaft to provide clearance between plate (55) and sanding disc. Using long T-handle Allen wrench, tighten set screw (57).

**NOTE:** There is a close fit between the edge of disc (58) and the disc shroud. To ease installation and positioning of disc, use an L-shaped tool (such as an Allen wrench) under outer edge of disc to support and position the disc while tightening the set screw.

29. Install plate (55) and secure with four screws (56). Check for clearance between plate (55) and sanding disc.
30. Install table (60) onto rod (74). Position table so it is level and tighten screw (65) against rod (74).
31. Install assembled table (88).
32. Connect electrical power and operate machine to check operation.

## 11.6 Replacing motor

1. Disconnect electrical power.
2. Remove four screws from base. With assistance of a second person, lift base from stand.

**NOTE:** Place base on bench. As an alternative, the stand may be used to support the base while removing drive motor screws.

3. Place base on bench with underside of base facing up.
4. Remove four hex head screws, nuts and washers from motor base.
5. Remove motor v-belt from motor pulley.
6. Remove motor from base.
7. Loosen set screw in pulley (18). Remove pulley.
8. Align set screw in pulley with flat on motor shaft and install pulley. Do not tighten set screw.
9. Install replacement V-belt over end of motor shaft and install motor in base. Secure with four screws, washers and nuts.
10. Install and tighten four hex bolts, nuts, and washers in the motor base.
11. Position pulley (18) on motor shaft so the V-belt is parallel with inner wall of base. Tighten set screw in pulley (20) against flat on motor shaft.
12. Place assembled base on stand. Secure with four screws, washers, nuts.
13. Connect electrical power and operate machine to check operation.

## 11.7 Additional servicing

Any additional servicing should be performed by authorized service personnel.

## 12.0 Troubleshooting J-4210 Belt-Disc Sander

Symptom	Possible Cause	Correction*
Machine does not start.	Blown fuse or tripped circuit breaker.	Determine reason for blown fuse/tripped breaker (such as a short circuit or motor overload). Correct reason for fault. Replace fuse/reset breaker.
	Motor failure.	Replace motor.
	Not connected to power source.	Check connections.
	Motor not wired for correct voltage.	Correct motor wiring.
	Motor not connected to correct voltage source.	Connect to proper voltage source.
Sanding belt does not track correctly.	Sanding belt stretched unevenly.	Replace sanding belt.
	V-belt worn.	Replace V-belt.
	Pulley worn.	Replace pulley.
Abrasive separates from disc.	Improperly bonded.	Clean residual adhesive from disc. Reapply adhesive-backed abrasive to the disc.
Sanding belt slips or stalls when pressure is applied.	Abrasive belt tension inadequate.	Tighten sanding belt.
	Excessive pressure being applied to platen housing.	Reduce pressure on sanding belt (and platen housing).
	Motor belt loose.	Tighten motor belt.
Disc stalls when pressure is applied.	Motor V-belt loose.	Tighten motor V-belt.
Frequent replacement of sanding belt.	Too much pressure being applied to work piece.	Reduce pressure on work piece.
	Full width of belt not being used.	Stroke across sanding belt using full width of belt surface.

\***WARNING:** Some corrections may require a qualified electrician.

## 13.0 Replacement Parts

Replacement parts are listed on the following pages. To order parts or reach our service department, call 1-800-274-6848 Monday through Friday, 8:00 a.m. to 5:00 p.m. CST. Having the Model Number and Serial Number of your machine available when you call will allow us to serve you quickly and accurately.

Non-proprietary parts, such as fasteners, can be found at local hardware stores, or may be ordered from JET.

Some parts are shown for reference only, and may not be available individually.

# 13.1.1 J-4210 Belt & Disc Sander – Exploded View

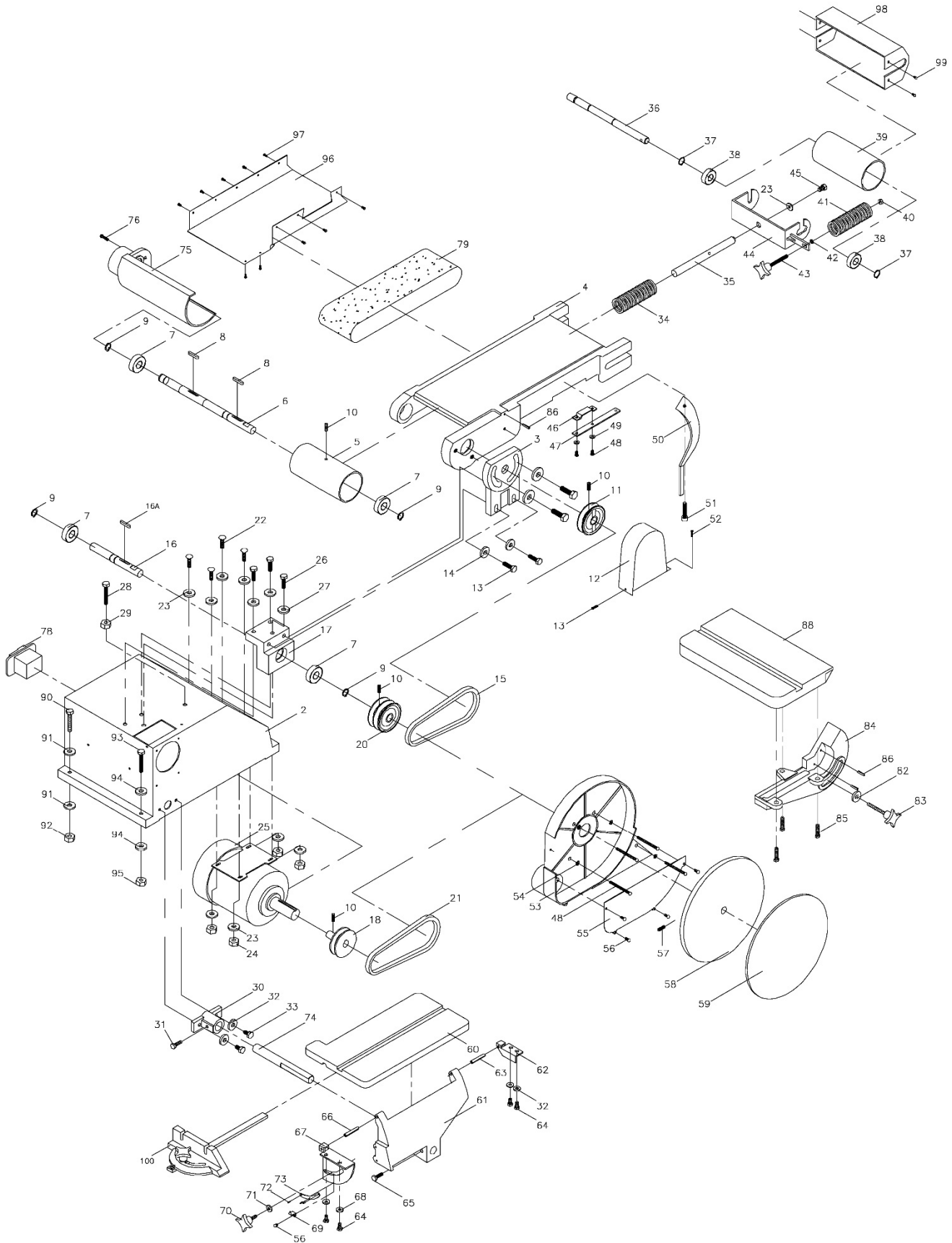

### 13.1.2 J-4210 Belt & Disc Sander – Parts List

Index No	Part No	Description	Size	Qty
2	J-5513011G	Base		1
3	J-5513012G	Bracket		1
4	J-5513013G	Platen		1
5	5513014	Drive Drum		1
6	5513015	Drive Drum Shaft		1
7	5513016	Bearing	6203ZZ	2
8	5513017	Key		1
8A	5513028	Key		1
9	5513018	Retaining Ring	S-17	2
10	5513019	Set Screw	1/4 X 3/8	1
11	J-5513020G	Pulley		1
12	J-5513021G	Pulley Cover		1
13	5513022	Screw	5/16 X 1-1/2	4
14	5513023	Plain Washer	5/16	4
15	5513024	V-Belt	A-18	1
16	5513025	Drive Pulley Shaft		1
17	J-5513026G	Bracket		1
18	J-5513027G	Motor Pulley		1
20	J-5513029G	Idler Pulley		1
21	5513030	V-Belt	A-25	1
22	5513031	Screw	5/16 X 3/4	4
23	5513032	Flat Washer	5/16	8
24	5513033	Hex Nut	5/16	4
25	5512767	Motor	1HP, 1PH	1
	5512767-SC	Start Capacitor (not shown)	300MFD 125VAC	1
26	5513035	Hex Screw	3/8 X 1	3
27	5513036	Flat Washer	3/8	3
28	5513037	Screw	3/8 X 1-1/2	1
29	5513038	Nut, Jam		1
30	J-5513039G	Mounting Bracket		1
31	5513040	Screw	5/16 X 1	1
32	5513041	Washer	1/4	6
33	5513042	Hex Screw	1/4 X 3/4	2
34	5513043	Spring	1/4	1
35	5513044	Shaft		1
36	5513045	Driven Drum Shaft		1
37	5513046	Retaining Ring	S-15	2
38	5513047	Bearing	6202ZZ	2
39	5513048	Driven Drum		1
40	5513049	Nut	1/4	1
41	5513050	Spring		1
42	5513051	Flat Washer		1
43	5513052	Threaded Rod, Belt Tracking Adjustment		1
44	5513054	Driven Drum Support		1
45	5513055	Screw	5/16 X 1/2	1
46	5513056	Bracket		1
47	5513057	Bar		1
48	5513058	Screw	3/16 X 1/2	6
49	5513059	Washer	3/16	2
50	5513060	Belt Tension Lever		1
51	5513061	Screw	5/16 X 1-1/4	1
52	5513062	Screw	3/16 X 3/8	2
53	J-5513063G	Disc Guard		1
54	5513064	Lock Washer	3/16	4
55	5513065	Cover Plate		1
56	5513066	Screw	3/16 X 1/4	5
57	5513067	Set Screw	6 X 10 MM	1
58	5512765	Aluminum Disc		1

Index No	Part No	Description	Size	Qty
59	5513071	Garnet Disc	10", 80 Grit	1
	5513073	Garnet Disc	10", 100 Grit	1
	5513075	Garnet Disc	10", 120 Grit	1
60	J-5513077G	Side Table		1
61	J-5513078G	Table Support		1
62	5513079	Table Support Bracket		1
63	5513080	Spring Pin		1
64	5513081	Screw	1/4 X 3/8	4
65	5513082	Hex Screw	5/16 X 1	1
66	5513083	Spring Pin		1
67	5513084	Table Support Bracket		1
68	5513085	Flat Washer		2
69	5513086	Pointer		1
70	5513087	Knob		1
71	5513088	Washer		1
72	5513089	Rivet		3
73	5513090	Scale		1
73A	5513091	Pointer		1
74	5513092	Table Support Rod		1
75	5513093	Belt Guard		1
76	5513094	Screw	3/16 X 5/8	1
77	5513095	Sanding Belt Cover (not shown)		1
77A	5513096	Cap Screw (not shown)		8
78	5512766	Switch Assembly		1
79	5051841	Abrasive Belt	6 x 48, 80 Grit	1
	5512764	Abrasive Belt	6 x 48, 100 Grit	1
	5513103	Abrasive Belt	6 x 48, 150 Grit	1
82	5513107	Washer		1
83	5513108	Knob	1/4 X 1-1/2	1
84	J-5512763G	Table Bracket		1
85	5513110	Screw	5/16 X 1-1/2	3
86	5513111	Pin	4 X 15	1
88	J-5513113G	Sanding Belt Table		1
89	5513114	Wrench (not shown)		1
90	5513115	Socket Head Screw		2
91	5513116	Flat Washer		2
92	5513117	Hex Nut		2
93	5513118	Hex Head Screw		2
94	5513119	Flat Washer		2
95	5513120	Hex Nut		2
96	J-5513479G	Belt Cover		1
97	5513480	Socket Head Screw		8
98	J-5514639G	Belt Guard		1
99	5514640	Screw		4
100	5517426	Miter Gauge		1
	5515308	Head, Complete		1

**13.2.1 J-4210 Stand – Exploded View**

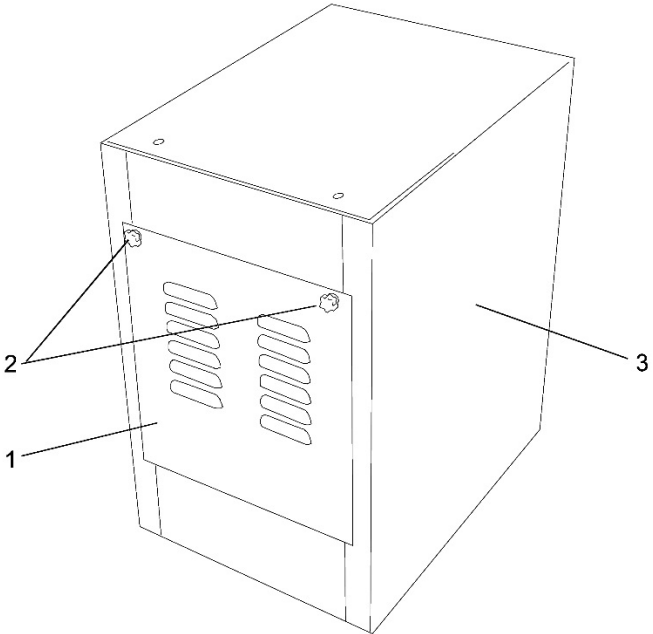

**13.2.2 J-4210 Stand – Parts List**

Index No	Part No	Description	Size	Qty
1	J-5513476G	Access Panel		1
2	5513477	Knob		2
3	414549	Complete Stand Assembly		1



# 14.0 Electrical Connections for J-4210

## 115V

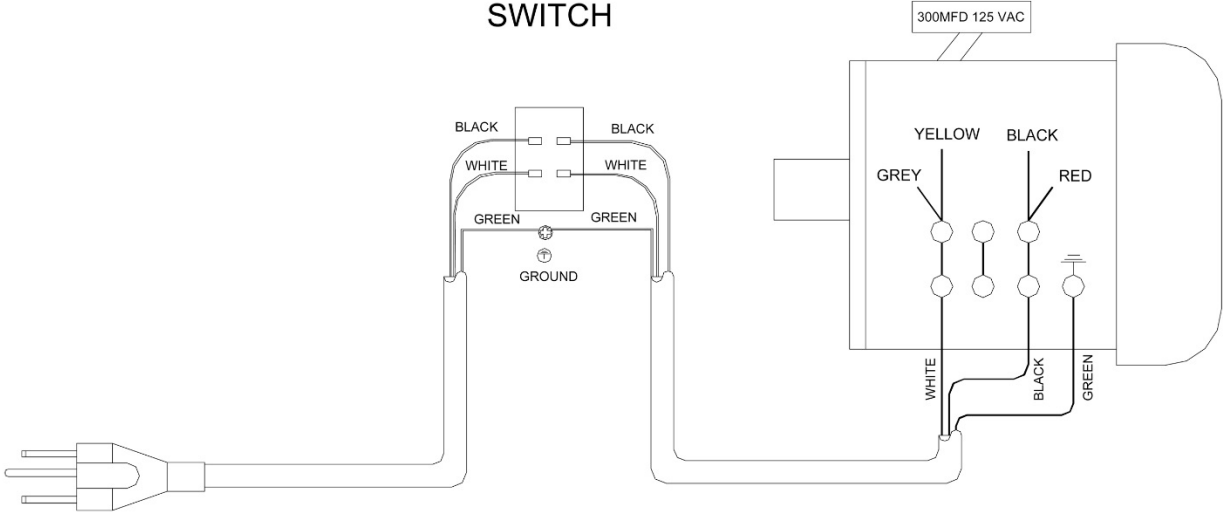

## 230V

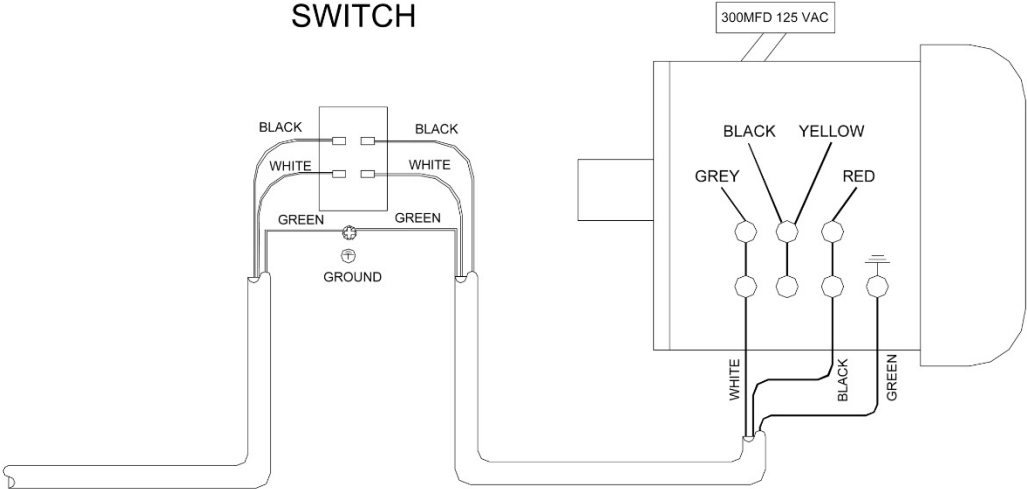

## 15.0 Warranty and service

JET warrants every product it sells against manufacturers' defects. If one of our tools needs service or repair, please contact Technical Service by calling 1-800-274-6846, 8AM to 5PM CST, Monday through Friday.

### Warranty Period

The general warranty lasts for the time period specified in the literature included with your product or on the official JET branded website.

- JET products carry a limited warranty which varies in duration based upon the product. (See chart below)
- Accessories carry a limited warranty of one year from the date of receipt.
- Consumable items are defined as expendable parts or accessories expected to become inoperable within a reasonable amount of use and are covered by a 90 day limited warranty against manufacturer's defects.

### Who is Covered

This warranty covers only the initial purchaser of the product from the date of delivery.

### What is Covered

This warranty covers any defects in workmanship or materials subject to the limitations stated below. This warranty does not cover failures due directly or indirectly to misuse, abuse, negligence or accidents, normal wear-and-tear, improper repair, alterations or lack of maintenance. JET woodworking machinery is designed to be used with Wood. Use of these machines in the processing of metal, plastics, or other materials outside recommended guidelines may void the warranty. The exceptions are acrylics and other natural items that are made specifically for wood turning.

### Warranty Limitations

Woodworking products with a Five Year Warranty that are used for commercial or industrial purposes default to a Two Year Warranty. Please contact Technical Service at 1-800-274-6846 for further clarification.

### How to Get Technical Support

Please contact Technical Service by calling 1-800-274-6846. **Please note that you will be asked to provide proof of initial purchase when calling.** If a product requires further inspection, the Technical Service representative will explain and assist with any additional action needed. JET has Authorized Service Centers located throughout the United States. For the name of an Authorized Service Center in your area call 1-800-274-6846 or use the Service Center Locator on the JET website.

### More Information

JET is constantly adding new products. For complete, up-to-date product information, check with your local distributor or visit the JET website.

### How State Law Applies

This warranty gives you specific legal rights, subject to applicable state law.

### Limitations on This Warranty

JET LIMITS ALL IMPLIED WARRANTIES TO THE PERIOD OF THE LIMITED WARRANTY FOR EACH PRODUCT. EXCEPT AS STATED HEREIN, ANY IMPLIED WARRANTIES OF MERCHANTABILITY AND FITNESS FOR A PARTICULAR PURPOSE ARE EXCLUDED. SOME STATES DO NOT ALLOW LIMITATIONS ON HOW LONG AN IMPLIED WARRANTY LASTS, SO THE ABOVE LIMITATION MAY NOT APPLY TO YOU.

JET SHALL IN NO EVENT BE LIABLE FOR DEATH, INJURIES TO PERSONS OR PROPERTY, OR FOR INCIDENTAL, CONTINGENT, SPECIAL, OR CONSEQUENTIAL DAMAGES ARISING FROM THE USE OF OUR PRODUCTS. SOME STATES DO NOT ALLOW THE EXCLUSION OR LIMITATION OF INCIDENTAL OR CONSEQUENTIAL DAMAGES, SO THE ABOVE LIMITATION OR EXCLUSION MAY NOT APPLY TO YOU.

JET sells through distributors only. The specifications listed in JET printed materials and on official JET website are given as general information and are not binding. JET reserves the right to effect at any time, without prior notice, those alterations to parts, fittings, and accessory equipment which they may deem necessary for any reason whatsoever. JET® branded products are not sold in Canada by JPW Industries, Inc.

### Product Listing with Warranty Period

90 Days – Parts; Consumable items
1 Year – Motors; Machine Accessories
2 Year – Metalworking Machinery; Electric Hoists, Electric Hoist Accessories; Woodworking Machinery used for industrial or commercial purposes
5 Year – Woodworking Machinery
Limited Lifetime – JET Parallel clamps; VOLT Series Electric Hoists; Manual Hoists; Manual Hoist Accessories; Shop Tools; Warehouse & Dock products; Hand Tools; Air Tools

NOTE: JET is a division of JPW Industries, Inc. References in this document to JET also apply to JPW Industries, Inc., or any of its successors in interest to the JET brand.



427 New Sanford Road  
LaVergne, Tennessee 37086  
Phone: 800-274-6848  
[www.jettools.com](http://www.jettools.com)