

POWERMATIC®

Operating Instructions and Parts Manual Deluxe Bench-top Mortiser Model: 701



Shown with optional chisel/bit sets

For serial no. 18077010001 and higher

Powermatic
427 New Sanford Road
LaVergne, Tennessee 37086
Ph.: 800-274-6848
www.powermatic.com

Part No. M-1791310
Revision D1 12/2018
Copyright © 2018 Powermatic

Warranty and Service

Powermatic® warrants every product it sells against manufacturers' defects. If one of our tools needs service or repair, please contact Technical Service by calling 1-800-274-6846, 8AM to 5PM CST, Monday through Friday.

Warranty Period

The general warranty lasts for the time period specified in the literature included with your product or on the official Powermatic branded website.

- Powermatic products carry a limited warranty which varies in duration based upon the product. (See chart below)
- Accessories carry a limited warranty of one year from the date of receipt.
- Consumable items are defined as expendable parts or accessories expected to become inoperable within a reasonable amount of use and are covered by a 90 day limited warranty against manufacturer's defects.

Who is Covered

This warranty covers only the initial purchaser of the product from the date of delivery.

What is Covered

This warranty covers any defects in workmanship or materials subject to the limitations stated below. This warranty does not cover failures due directly or indirectly to misuse, abuse, negligence or accidents, normal wear-and-tear, improper repair, alterations or lack of maintenance. Powermatic woodworking machinery is designed to be used with Wood. Use of these machines in the processing of metal, plastics, or other materials outside recommended guidelines may void the warranty. The exceptions are acrylics and other natural items that are made specifically for wood turning.

Warranty Limitations

Woodworking products with a Five Year Warranty that are used for commercial or industrial purposes default to a Two Year Warranty. Please contact Technical Service at 1-800-274-6846 for further clarification.

How to Get Technical Support

Please contact Technical Service by calling 1-800-274-6846. **Please note that you will be asked to provide proof of initial purchase when calling.** If a product requires further inspection, the Technical Service representative will explain and assist with any additional action needed. Powermatic has Authorized Service Centers located throughout the United States. For the name of an Authorized Service Center in your area call 1-800-274-6846 or use the Service Center Locator on the Powermatic website.

More Information

Powermatic is constantly adding new products. For complete, up-to-date product information, check with your local distributor or visit the Powermatic website.

How State Law Applies

This warranty gives you specific legal rights, subject to applicable state law.

Limitations on This Warranty

POWERMATIC LIMITS ALL IMPLIED WARRANTIES TO THE PERIOD OF THE LIMITED WARRANTY FOR EACH PRODUCT. EXCEPT AS STATED HEREIN, ANY IMPLIED WARRANTIES OF MERCHANTABILITY AND FITNESS FOR A PARTICULAR PURPOSE ARE EXCLUDED. SOME STATES DO NOT ALLOW LIMITATIONS ON HOW LONG AN IMPLIED WARRANTY LASTS, SO THE ABOVE LIMITATION MAY NOT APPLY TO YOU.

POWERMATIC SHALL IN NO EVENT BE LIABLE FOR DEATH, INJURIES TO PERSONS OR PROPERTY, OR FOR INCIDENTAL, CONTINGENT, SPECIAL, OR CONSEQUENTIAL DAMAGES ARISING FROM THE USE OF OUR PRODUCTS. SOME STATES DO NOT ALLOW THE EXCLUSION OR LIMITATION OF INCIDENTAL OR CONSEQUENTIAL DAMAGES, SO THE ABOVE LIMITATION OR EXCLUSION MAY NOT APPLY TO YOU.

Powermatic sells through distributors only. The specifications listed in Powermatic printed materials and on the official Powermatic website are given as general information and are not binding. Powermatic reserves the right to effect at any time, without prior notice, those alterations to parts, fittings, and accessory equipment which they may deem necessary for any reason whatsoever.

Product Listing with Warranty Period

90 Days – Parts; Consumable items
1 Year – Motors, Machine Accessories
2 Year – Woodworking Machinery used for industrial or commercial purposes
5 Year – Woodworking Machinery

NOTE: Powermatic is a division of JPW Industries, Inc. References in this document to Powermatic also apply to JPW Industries, Inc., or any of its successors in interest to the Powermatic brand.

Table of Contents

Warranty and Service.....	2
Table of Contents.....	3
Warnings.....	4
Introduction.....	6
Specifications.....	6
Unpacking.....	7
Contents of the Mortiser Carton.....	7
Assembly.....	7
Gib Screws.....	7
Operating Handle.....	8
Gib Adjustment.....	8
Overview – Chuck Extension.....	9
Installing the Chuck Extension.....	9
Installing Chisel and Auger.....	10
Securing Mortiser to Work Bench.....	11
Tool Holder.....	11
Diamond Sharpening Cone.....	11
Electrical.....	11
115V/230V Operation.....	11
Power Connection.....	11
Grounding Instructions.....	12
Operating Controls.....	12
Start/Stop Switch.....	12
Adjustments.....	12
Depth Stop Adjustment.....	12
Chisel Parallel to Workpiece.....	13
Fence and Clamp.....	14
Fence Adjustment.....	14
Hold-down Clamp.....	14
Operation.....	15
Rotating Column.....	15
Maintenance.....	16
General.....	16
Sharpening Chisel and Auger.....	16
Auger.....	16
Chisel.....	16
Handle Position Adjustment.....	12
Lubrication.....	16
Storage.....	16
701 Mortiser Assembly Drawing.....	17
701 Mortiser Parts List.....	18
Wiring Diagram for 701 Mortiser.....	20
Optional Accessories.....	20
Ordering Replacement Parts.....	20
Dimensions for 701 with premium chisels mounted.....	21



Warnings

1. Read and understand the entire owner's manual before attempting assembly or operation.
2. Read and understand the warnings posted on the machine and in this manual. Failure to comply with any of these warnings may cause serious injury.
3. Replace the warning labels if they become obscured or removed.
4. This mortiser is designed and intended for use by properly trained and experienced personnel only. If you are not familiar with the proper and safe operation of a mortiser, do not use until proper training and knowledge have been obtained.
5. Do not use this mortiser for other than its intended use. If used for other purposes, Powermatic disclaims any real or implied warranty and holds itself harmless from any injury that may result from that use.
6. Always wear approved safety glasses/face shields while using this mortiser. Everyday eyeglasses only have impact resistant lenses; they are not safety glasses.
7. Before operating this mortiser, remove tie, rings, watches and other jewelry, and roll sleeves up past the elbows. Remove all loose clothing and confine long hair. Non-slip footwear or anti-skid floor strips are recommended. Do not wear gloves.
8. Wear ear protectors (plugs or muffs) during extended periods of operation.
9. Do not operate this machine while tired or under the influence of drugs, alcohol or any medication.
10. Make certain the switch is in the **OFF** position before connecting the machine to the power supply.
11. Make certain the machine is properly grounded.
12. Make all machine adjustments or maintenance with the machine unplugged from the power source.
13. Remove adjusting keys and wrenches. Form a habit of checking to see that keys and adjusting wrenches are removed from the machine before turning it on.
14. Keep safety guards in place at all times when the machine is in use. If removed for maintenance purposes, use extreme caution and replace the guards immediately.
15. Make sure the mortiser is firmly secured to the floor or bench before use.
16. Check damaged parts. Before further use of the machine, a guard or other part that is damaged should be carefully checked to determine that it will operate properly and perform its intended function. Check for alignment of moving parts, binding of moving parts, breakage of parts, mounting and any other conditions that may affect its operation. A guard or other part that is damaged should be properly repaired or replaced.
17. Provide for adequate space surrounding work area and non-glare, overhead lighting.
18. Keep the floor around the machine clean and free of scrap material, oil and grease.
19. Keep visitors a safe distance from the work area. **Keep children away.**
20. Make your workshop child proof with padlocks, master switches or by removing starter keys.
21. Give your work undivided attention. Looking around, carrying on a conversation and "horse-play" are careless acts that can result in serious injury.
22. Maintain a balanced stance at all times so that you do not fall or lean against the chisel and drill bits or other moving parts. Do not overreach or use excessive force to perform any machine operation.
23. Use the right tool at the correct speed and feed rate. Do not force a tool or attachment to do a job for which it was not designed. The right tool will do the job better and safer.
24. Use recommended accessories; improper accessories may be hazardous.
25. Maintain tools with care. Keep chisel and drill bits sharp and clean for the best and safest performance. Follow instructions for lubricating and changing accessories.

26. Make sure the work piece is securely attached or clamped to the table. Never use your hand to hold the work piece.
27. Turn off the machine before cleaning. Use a brush or compressed air to remove chips or debris — do not use your hands.
28. Do not stand on the machine. Serious injury could occur if the machine tips over.
29. Never leave the machine running unattended. Turn the power off and do not leave the machine until it comes to a complete stop.
30. Remove loose items and unnecessary work pieces from the area before starting the machine.

⚠ WARNING: This product can expose you to chemicals including lead which is known to the State of California to cause cancer and birth defects or other reproductive harm. For more information go to <http://www.p65warnings.ca.gov>.

⚠ WARNING: Drilling, sawing, sanding or machining wood products generates wood dust and other substances known to the State of California to cause cancer. Avoid inhaling dust generated from wood products or use a dust mask or other safeguards for personal protection.

Wood products emit chemicals known to the State of California to cause birth defects or other reproductive harm. For more information go to <http://www.p65warnings.ca.gov/wood>.

Familiarize yourself with the following safety notices used in this manual:

⚠ CAUTION This means that if precautions are not heeded, it may result in minor injury and/or possible machine damage.

⚠ WARNING This means that if precautions are not heeded, it may result in serious injury or possibly even death.

- - SAVE THESE INSTRUCTIONS - -

Introduction

This manual is provided by Powermatic covering the safe operation and maintenance procedures for a Model 701 Deluxe Bench-top Mortiser. This manual contains instructions on installation, safety precautions, general operating procedures, maintenance instructions and parts breakdown. This machine has been designed and constructed to provide consistent, long-term operation if used in accordance with instructions set forth in this manual. If there are any questions or comments, please contact either your local supplier or Powermatic. Powermatic can also be reached at our web site: www.powermatic.com.

Specifications

Model No.	701
Stock No.	1791310
Chisel shank capacity, maximum.....	3/4"
Chuck capacity, maximum	1/2"
Chisel stroke, maximum.....	5-1/2"
Chisel center to fence distance	4-3/8"
Bushing sizes provided	5/8", 3/4"
Fence size	12-1/2" x 2-5/8"
Base size	16-5/16" x 13-3/4"
Capacity under hold-down	5"
Spindle speed	1725 RPM
Motor (TEFC)	3/4 HP, 1 PH, 4P, 115V/230, Pre-wired 115V
Weight (net/shipping)	84 / 92 lb

The above specifications were current at the time this manual was published, but because of our policy of continuous improvement, Powermatic reserves the right to change specifications at any time and without prior notice, without incurring obligations.

Unpacking

Remove contents from the shipping carton. Check for damage and ensure all parts are intact. Any damage should be reported immediately to your distributor and shipping agent. Read the manual thoroughly to familiarize yourself with the correct assembly and maintenance procedures and proper safety precautions.

Contents of the Mortiser Carton

- 1 ea – Mortiser (not shown)
- 1 ea – 3/4" Chisel Bushing (A)
- 1 ea – Chuck Extension Adaptor (B)
- 1 ea – Chuck Key (C)
- 1 ea – Operating Handle (D)

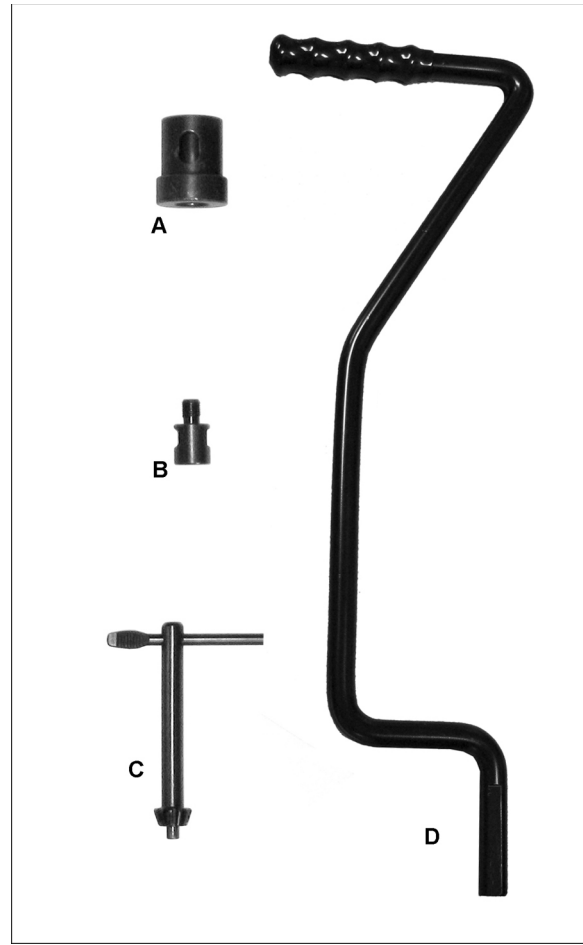

Contents of the Mortiser Carton

Assembly

⚠WARNING Do not connect the machine to power source until completely assembled. Read and understand the entire manual.

Gib Screws

The Powermatic Model 701 Deluxe Bench-top Mortiser is packaged with the head locked to prevent movement during shipment and is in the down position.

Referring to Figure 1:

1. Using a 10mm wrench loosen three lock nuts.
2. With a 3mm hex wrench loosen three gib screws the same amount. Loosen enough to permit the head to move freely on the column.

Do not tighten. The gib adjustment will be done later.



Figure 1

Operating Handle

Referring to Figure 2:

The *operating handle* can be mounted on either the left- or right-hand side of the mortiser. The handle *hub* (D) comes mounted on the right-hand side from the factory. If right-hand operation is desired skip steps 1–3 and proceed to step 4. For left-hand operation the hub must be moved to the left side as follows:

1. Unscrew and remove the hub *lock knob* (A), *flat washer* (B), *spring* (C) and *hub* (D) from the *pinion shaft* (E).
2. Remove the protective sleeve from the gear shaft on the left side of the mortiser.
3. Install the *hub* (D), *spring* (C) and *flat washer* (B) on the left-side pinion shaft and secure the assembly with the hub *lock knob* (A).

Referring to Figure 3:

4. Loosen the lock handle (F) located on the hub (H).
5. Insert the operating handle into the bracket on the hub. Position the upper part of the handle away from the mortiser allowing it to clear the *switch box* during operation.

Note: If handle is mounted on the right side, also position the handle so the upper portion is away from the mortiser

Note: The handle assembly is spring-loaded permitting the operating handle to be repositioned by pulling out the *hub* (H) and repositioning it in 36° increments (ten positions total) on the pinion shaft.

Gib Adjustment

Now that the operating handle has been installed, the gib screws that were previously loosened should be adjusted.

Alternately raise and lower the mortiser head with the operating handle, then adjust each of the three set screws (Figure 1) with a 3mm hex wrench the same number of turns.

Tighten the set screws to remove play from the column but do not over tighten such that it is difficult to raise and lower the operating handle.

When adjustment is complete, tighten the lock nut with a 10mm wrench while maintaining the position of the setscrew with the 3 mm hex wrench.

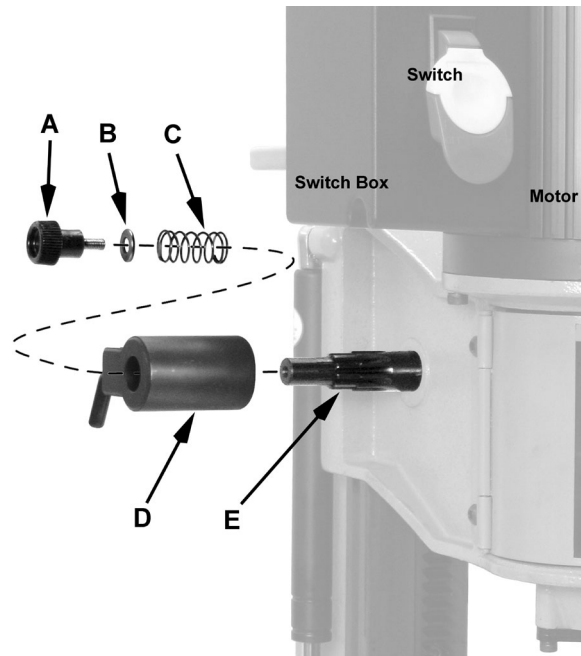

Figure 2

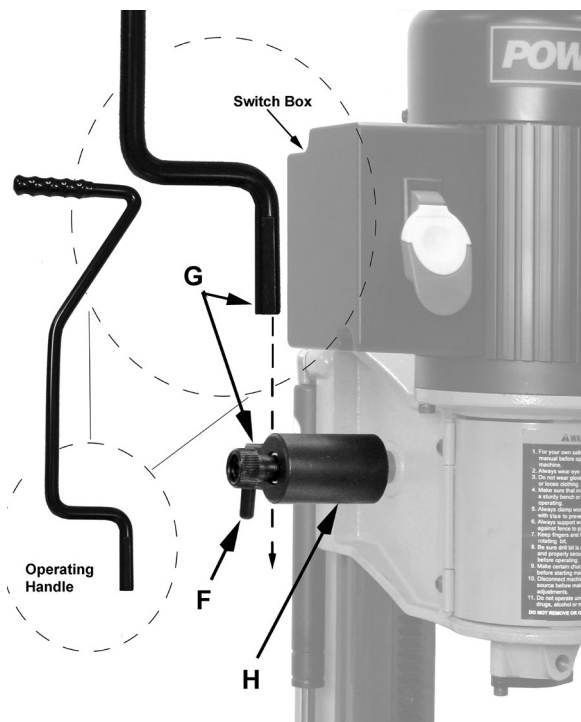

Figure 3

Overview – Chuck Extension

Do you need it

The 701 Mortiser comes with the chuck already assembled at the factory, intended to be used with augers having long shanks. Augers come with long or short shanks (Figure 4) depending on the manufacturer.

Long shank augers

If you plan to install an auger with a long shank, you can skip this section and proceed to the *Installing Chisel and Auger* section on page 10.

Short shank augers

If you plan to install an auger with a short shank, proceed to *Installing the Chuck Extension* section.



Figure 4

Installing the Chuck Extension

Referring to Figure 4, remove the chuck from the motor shaft as follows:

1. Open door (A).
2. Unscrew and remove the *chuck* (B) from the *motor shaft* (C) using a 12mm wrench placed on the flat indents of the *shaft* (C) and the chuck key in the *chuck* (B).
3. Thread the *chuck extension* (D) onto the *motor shaft* (C).
4. Tighten using 12mm and 14mm wrenches respectively on flat sides of the *motor shaft* (C) and *chuck extension* (D).
5. Thread the *chuck* (B) onto the *chuck extension* (D).
6. Tighten using a 14mm wrench on flat sides of the *chuck extension* (D) and the chuck key in the *chuck* (B).

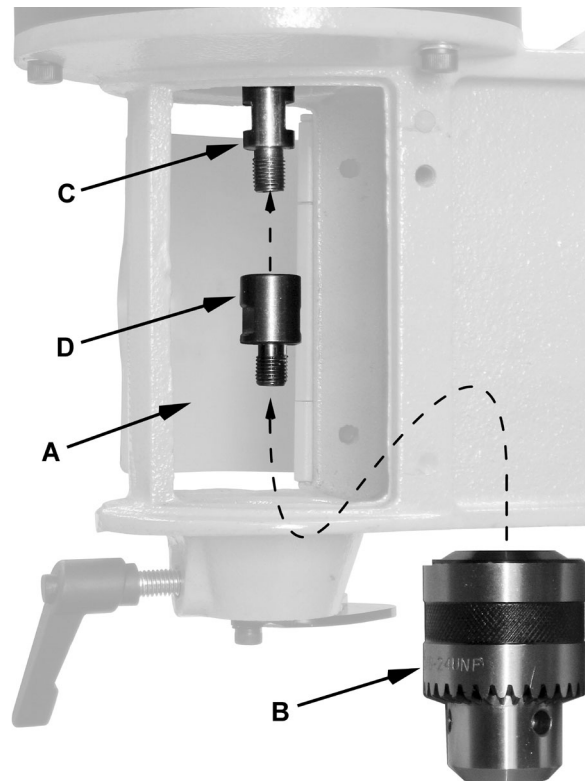

Figure 5

Installing Chisel and Auger

Referring to Figure 6:

1. Open door (A).
2. Swing two bushing spacers (B) away from the head (C).
3. Loosen the lock screw (D).
4. Insert the chisel bushing* (E) into the head (C), lining up the hole (F) with the lock screw (D).
5. Set the lock screw (D) so the threaded end extends into the hole (F) of the bushing (E), holding it in place. The bushing should still have about 1/4" of vertical travel margin.

The *chisel to auger clearance* (see Figure 5) is the vertical clearance between the auger and chisel.

When assembled, the proper *chisel to auger clearance* is dependant on the chisel size and the position of the chisel (adjustable) with respect to the auger (which is fixed). The position of the chisel is set with spacers described in the following steps.

6. Position spacers (B) so they rest against the bushing above the lip (J).

Number of spacers to use:

- For chisels 1/2" or less – use the upper spacer only
- For chisels greater than 1/2" – use both spacers

⚠WARNING Chisels are extremely sharp. Use extreme care when handling to prevent personal injury.

7. Insert the auger (K) into the chisel (L). Then insert the assembly through the bushing (E). Using gloves or a block of wood, press up on the auger as far as it will go. The shank should slide into the opening in the bottom of the chuck (M).
8. Using the chuck key, tighten the chuck (M) to secure the auger (K).
9. Move the spacers (B) away from the bushing (E), push the chisel and bushing up against the head (C); then tighten the lock screw (D).

Hint: Set the slot in the side of the chisel to the left or right if the workpiece is to be moved laterally and front or back if it is to be moved from front to back. The workpiece should be moved so that the slot in the chisel is releasing chips into the already cut part of the workpiece (see Figure 13).

* Only if changing bushings. The 701 Mortiser comes with the 5/8" bushing already installed.

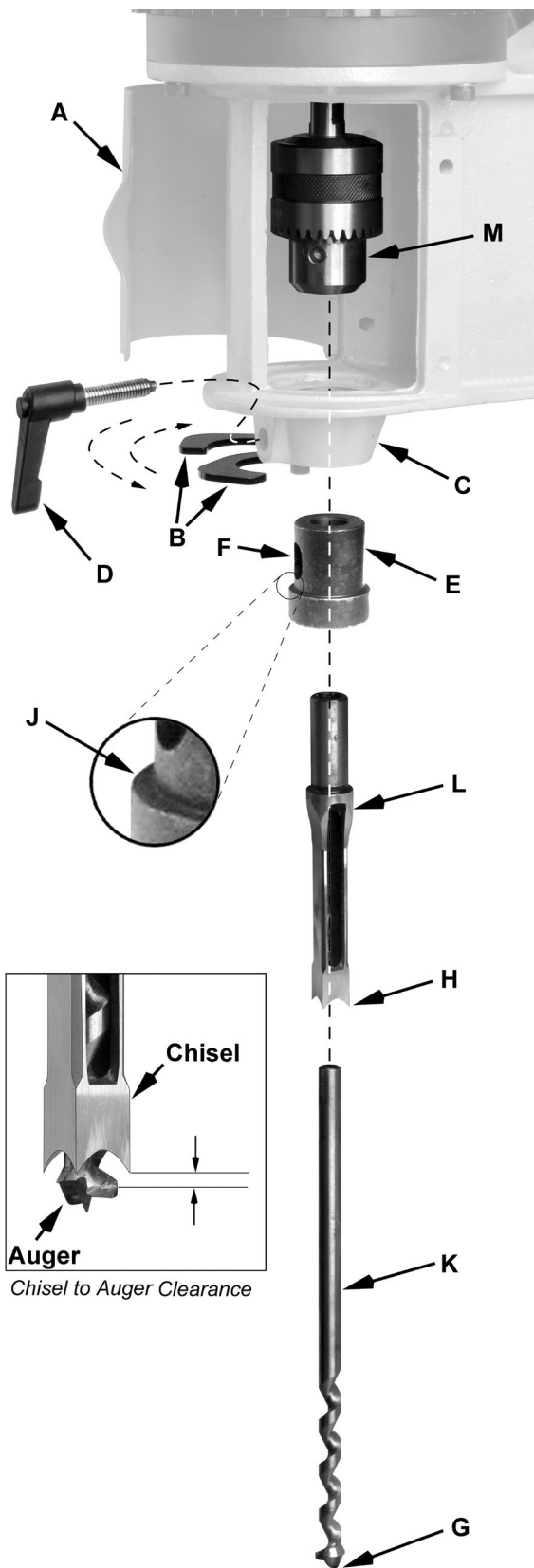

Figure 6

Note: This would be a good time to make sure that the chisel is parallel to the workpiece. See the *Chisel Parallel to Workpiece* section.

Securing Mortiser to Work Bench

It is highly recommended to secure the mortiser to the workbench to prevent the possibility of tipping, sliding or "walking" during operation.

Secure the mortiser to the bench with fasteners (not supplied) through four holes located in the base (Figure 7).

Tool Holder

Referring to Figure 8:

The 701 Bench-top Mortiser has a *tool holder* (A) that is installed at the factory and requires no assembly. It can be used to store the extra *bushing* (B), *chuck key* (C), *extension* (D) as well as any additional chisels and accessories.

Diamond Sharpening Cone

Referring to Figure 8:

1. From hardware kit insert the *diamond sharpening cone* (E) into the *opening* (F) at the top of the column.
2. Secure with the *setscrew* (G). The threaded opening is located behind the *tool holder* (A) which needs to be raised to access.

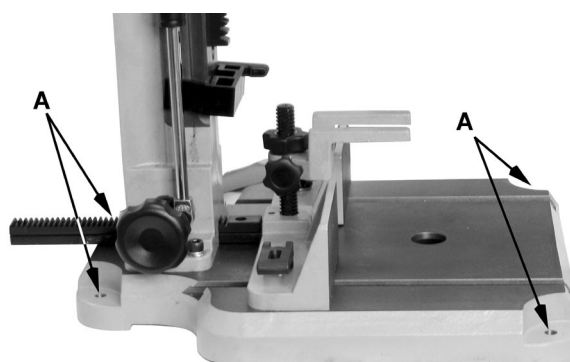

Figure 7

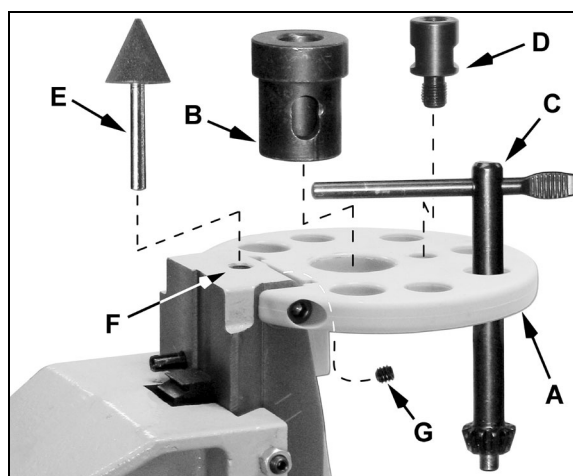

Figure 8

Electrical

115V/230V Operation

The Powermatic 701 Mortiser comes pre-wired from the factory to operate at 115V. The motor can be rewired to operate at 230V (see Wiring Diagram) which will also require a 230V plug and electrical outlet. If unsure, consult a qualified electrician.

Power Connection

⚠WARNING Do not operate this machine in damp locations.

A separate electrical circuit should be used for your machines. This circuit should be protected with a 15 Amp time lag fuse. If an extension cord is used, use only 3-wire extension cords which have 3-prong grounding type plugs and matching receptacle, which will accept the machine's plug. Before connecting the machine to the power line, make sure the switch is in the *Off* position and be sure that the electric current is of the same characteristics as indicated on the machine. All line connections should make good contact. Running on low voltage will damage the machine.

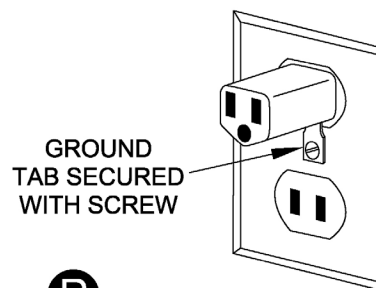
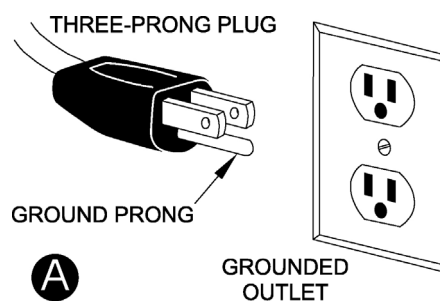

Figure 9

Grounding Instructions

⚠WARNING This machine must be grounded while in use to protect the user from shock

In the event of a malfunction or breakdown, grounding provides a path of least resistance for electric current to reduce the risk of electric shock.

If you are not sure whether your outlet is properly grounded, consult a qualified electrician.

Referring to Figure 9: As received from the factory, your mortiser is ready to run at 115-volt operation. This mortiser is intended for use on a circuit that has an outlet and a plug that looks like the one illustrated in (A). A temporary adaptor, which looks like the adaptor shown in (B), may be used to connect this plug to a two-pole receptacle if a properly grounded outlet is not available. The temporary adaptor should only be used until a properly grounded outlet can be installed by a qualified electrician. This adaptor is not applicable in Canada. The green colored rigid ear, lug, or tab, extending from the adaptor, must be connected to a permanent ground such as a properly grounded outlet box.

Operating Controls

Start/Stop Switch

Referring to Figure 10:

The *Start/Stop switch* is located to the left of the motor. Flip the switch out to start; flip in to stop.

The yellow insert is a *switch lock* which prevents the mortiser from being started when removed.

Adjustments

Depth Stop Adjustment

Referring to Figure 11:

A *depth stop* is provided to limit the depth, or downward travel, of the chisel. This enables the operator to make repeated boring operations without the need to measure each bore. To adjust:

1. Loosen the *lock handle* (A) and bring the *depth stop* (B) to rest at the bottom of the column.
2. With the *operating handle* (C) lower the *head* (D) until the *chisel* (E) is at the desired depth.
3. Bring the *depth stop* (B) up until it comes to rest against the bottom of the *head* (D).
4. Tighten the *lock handle* (A).

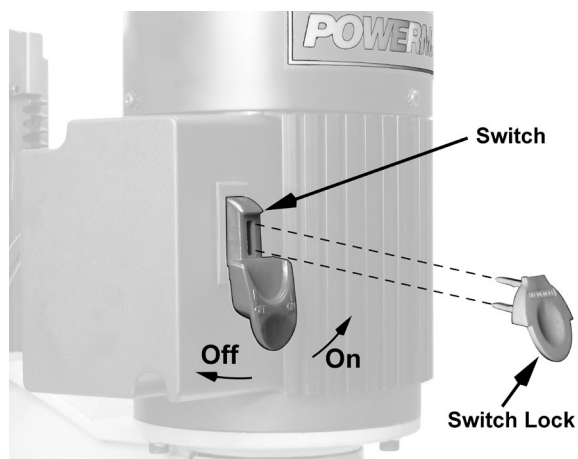

Figure 10

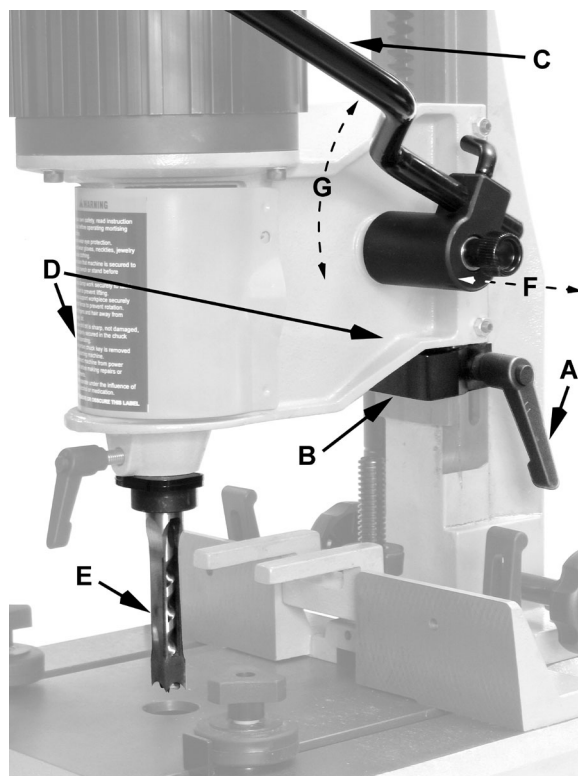

Figure 11

Handle Position Adjustment

Referring to Figure 11:

The handle assembly is spring-loaded permitting the *operating handle* (C) to be repositioned by pulling out the *hub* (F) and repositioning it (G) in 36° increments on the pinion shaft for a total of ten available positions.

Chisel Parallel to Workpiece

Referring to Figure 12:

The chisel can be adjusted parallel to the workpiece as follows:

1. Loosen the two *clamps* (A) that secure the *fence* (B).
2. With the *adjust knob* (C), move the fence back far enough to insert the *workpiece* (D) between the *chisel* (F) and *fence* (B). Raise the workpiece hold-down *clamp* (E) if necessary.
3. With the *operating handle* (G) bring the head down until the chisel points are almost at the table level.
4. Bring the *fence* (B) forward with the *adjust knob* (C) until the front edge of the *workpiece* (D) rests against the back surface of the chisel (F), but do not force.
5. Loosen the *chisel lock handle* (H). This will allow the chisel to rotate.

Further adjust the chisel by hand if needed.

6. Tighten the *lock handle* (H) while making sure the bushing maintains contact with the head casting to preserve the clearance setting.

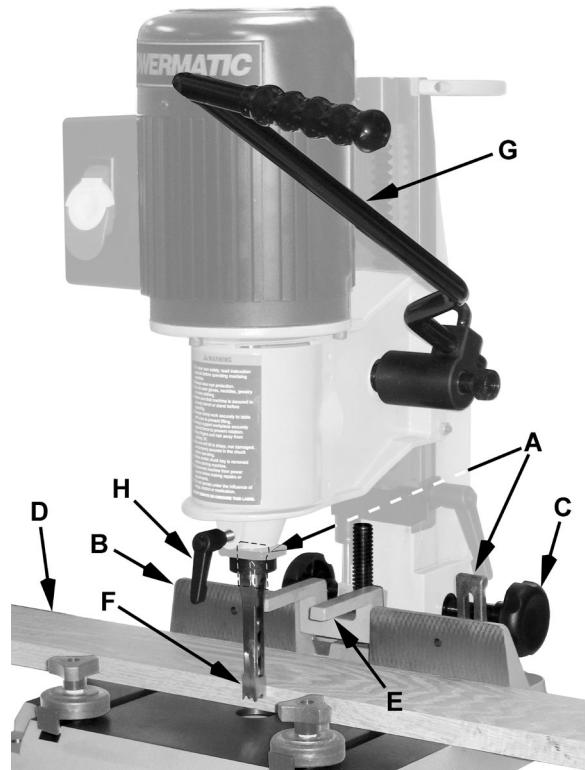

Figure 12

Fence and Clamp

Referring to Figure 13:

The 701 Mortiser is equipped with a forward/backward movement adjustable *fence* (B) and *hold-down clamp* (F, K, L) for securing the workpiece during mortising operations.

Fence Adjustment

To adjust the *fence* (B) forward or backward:

1. Loosen two *clamps* (A) that lock the *fence*.
2. Turn the *knob* (C) and adjust the *fence* (B) *forward* or *backward* (D) to the desired position.
3. Lock the *clamps* (A).

Hold-down Clamp

There are two ways that the hold-down clamp can be used. Both options are described below.

Option One – workpiece securely clamped to the table. If multiple mortises are needed, this will require the clamp to be loosened, workpiece moved, and clamp secured again.

To clamp the workpiece:

1. Loosen the *clamp lock knob* (H) and *clamp position lock knob* (G).
2. Place the workpiece on the *table* (E) under the prongs of the *clamp* (F) (see **Note** below) and against the *fence*.
3. Tighten the *clamp lock knob* (H) until the workpiece is secured.

Option two – workpiece partially clamped. If multiple mortises are needed, the workpiece can be moved by hand without repetitively loosening and tightening the clamp.

To clamp the workpiece:

1. Loosen the *clamp lock knob* (H) and *clamp position lock knob* (G).
2. Place the workpiece on the *table* (E) (see **Note** below) under the prongs of the *clamp* (F) and against the *fence* (B).
3. Bring the clamp down so the prongs rest on the workpiece, but do not press against the workpiece.
4. Tighten the *clamp position lock knob* (G).

This will constrain the workpiece and prevent it from being lifted when the chisel is raised, yet still allow the workpiece to be repositioned by hand. However, the operator will still need to hold the workpiece in position against the fence.

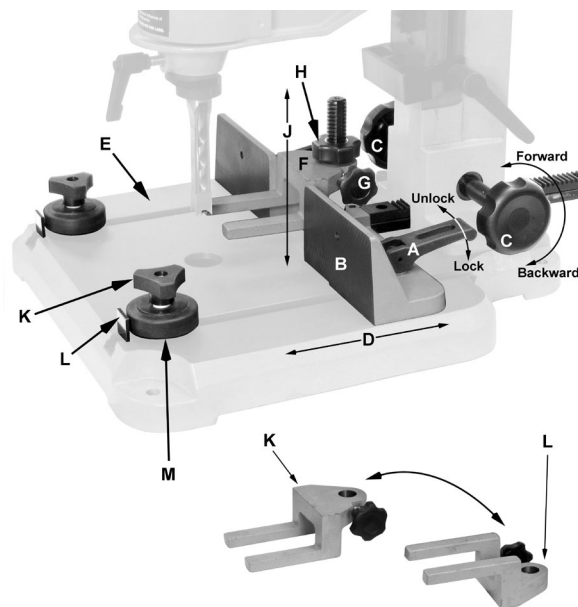

Figure 13

The following step is an option which will hold the workpiece securely against the fence yet still allow operator to reposition by hand.

5. Loosen the roller guides *lock knobs* (K).
6. Press the *tabs* (L) to secure the workpiece between the *wheels* (M) and *fence* (B).
7. Tighten the *lock knobs* (K).

Note: If needed, the hold-down clamp can be reversed (K, L) to accommodate a wide range of wood thicknesses.

Operation

1. Set the *depth stop* to the required depth of cut (refer to the *Depth Stop Adjustment* section on page 12).
2. Place workpiece on table and against the fence.
3. Adjust the fence until the workpiece is in the correct position (see the *Fence and Clamp* section on page 14).
4. Clamp the workpiece or set the clamp to the desired height as described in the *Fence and Clamp* section on page 14)

⚠WARNING Before turning the machine on, verify that the chuck key is not in the chuck.

5. Turn on the machine and feed the *chisel and auger* steadily into workpiece by pulling down the *operating handle*.

After the first cut, move the workpiece along for each successive cut. The direction of movement must allow the chips to clear freely. Move the workpiece so that the slot in the chisel is releasing chips into the already cut part of the workpiece (Figure 14).

⚠CAUTION Do not have the chisel slot against the blind end of the mortise, as the chips will not be able to clear the chisel. This can cause overheating and possible breakage of chisel or auger.

When cutting deep mortises, make the cut in several stages of approximately 1" each, to allow chips to clear. To prevent breakout at the back of the workpiece when cutting through mortises, use a piece of scrap material under the workpiece as support.

Rotating Column

Referring to Figure 15:

The column can be rotated 180° as shown to permit mortising large workpieces off the table. To rotate the column:

1. Using a 4mm hex wrench, remove four screws, lock washers and flat washers (C) **Note:** only one screw is visible in Figure 15.
2. Rotate the *column* (A) 180°.
3. Replace the four screws, lock washers and flat washers.

⚠WARNING The base must be secured to the work bench.

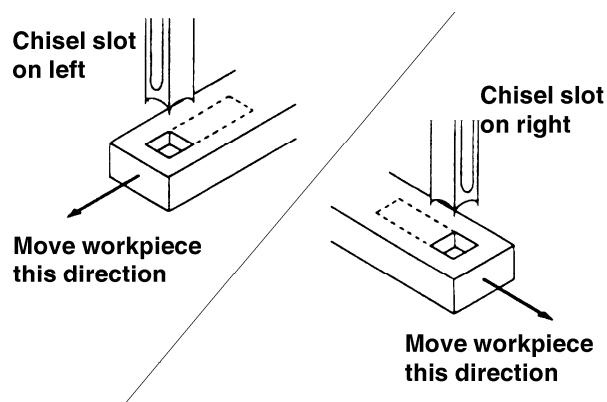

Figure 14

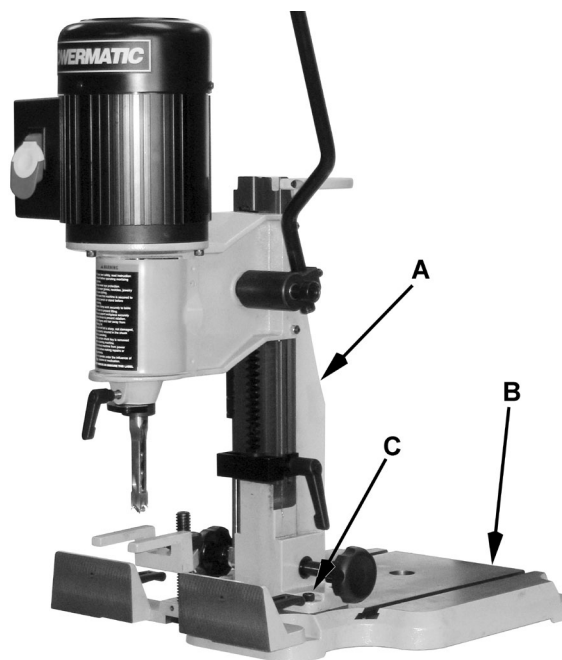

Figure 15

Maintenance

⚠WARNING Before any intervention on the machine, disconnect it from the electrical supply by pulling out the plug or switching off the main switch! Failure to comply may cause serious injury.

General

A coat of paste wax applied to the table and column will help to keep the surfaces clean.

If the power cord is worn, cut, or damaged in any way, have it replaced immediately.

The Mortiser requires only minor maintenance, such as cleaning and lubrication and routine adjustment and sharpening of the chisel and auger.

Dust the machine down after each use and, as necessary, use light applications of oil or grease to lubricate linkages, moving parts, etc.

Sharpening Chisel and Auger

The chisel and auger should be kept sharp for best performance. Blunt edges will give inaccurate mortises and can lead to overheating and breakage to chisel or auger. If chisel and auger are badly worn and become difficult to sharpen, they should be replaced.

Auger

Sharpen the auger by using a small, smooth file, following the original shape of the auger. File the inside edge of the spur, the sides of the brad point, and the cutting edge inwards toward the flute of the auger (Figure 16).

Do not file the outside edge of the spur, as this will affect the diameter of the auger.

Chisel

Referring to Figure 17:

Sharpen the *chisel* (A) with the *chisel sharpening cone* (B) located on the top of the column next to the tool holder. Set the *chisel* (A) on the *sharpening cone* (B) and rotate back and forth until sharpened (C).

Note: Make sure the set-screw is tight to prevent the cone from spinning.

Using a fine stone or micro-abrasive on a flat surface, lap the outside faces of the mortise bit to remove any burrs.

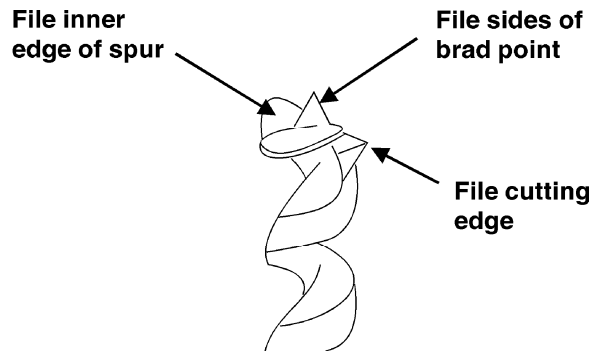

Figure 16

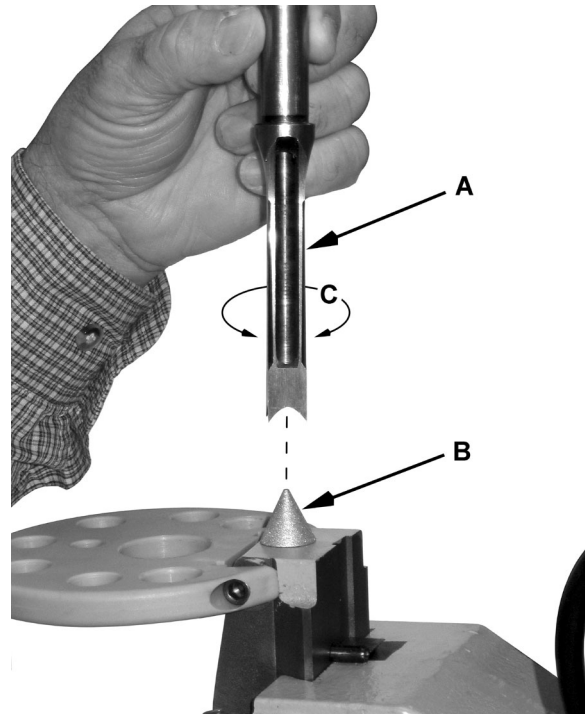

Figure 17

Lubrication

All of the ball bearings are packed with grease at the factory. They require no further lubrication. Periodically grease the gears, racks, and table pivot points with a #2 tube grease.

Periodically clean and oil any exposed machine surfaces, such as: dove-tail ways and slides, and table surface.

Storage

If the mortiser will be stored for an extended period, use the depth stop to help secure the head in position; this will relieve stress upon the hydraulic cylinder.

701 Mortiser Assembly Drawing

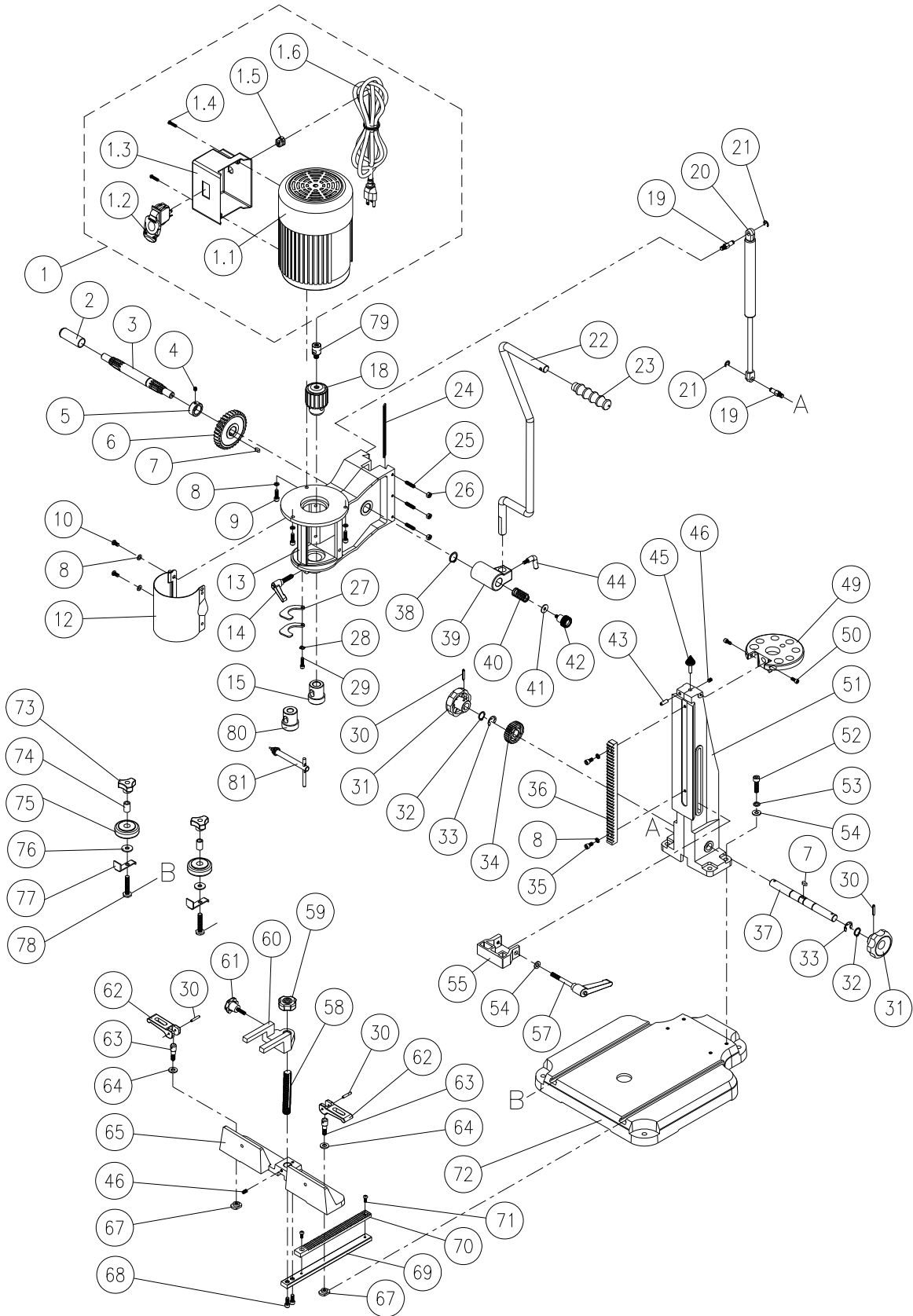

Patent No. US 7,509,984
US 7,243,692

701 Mortiser Parts List

Index No.	Part No.	Description	Size	Qty
1	701-164MA	Motor Assembly (includes #1.1 thru 1.10)		1
1.1	701-164M	Motor	3/4HP, 115/230V, 1PH, 60HZ	1
1.2	994534	Switch		1
1.3	701-165B	Switch Box		1
1.4	TS-081C052	Phillips Pan Hd Machine Screw	#10-24UNC x 3/4L	2
1.5	701-167B	Strain Relief		1
1.6	701-168B	Power Cord	SJT16AWG x 3C x 210CM	1
1.7	701-164AB	Fan (not shown)		1
1.8	701-164BB	Fan Cover (not shown)		1
1.9	701-164CB	Starting Capacitor (not shown)	200MFD 125VAC	1
1.10	701-164DB	Running Capacitor (not shown)	30mF 250VAC	1
2	701-102B	Shaft Cap		1
3	701-161B	Pinion Shaft		1
4	TS-1523011	Socket Hd Set Screw	M6-1.0 x 6L	1
5	701-159B	Collar		1
6	701-158B	Gear		1
7	WP2510-215	Key, Dbl Rd Hd	5 x 5 x 12L	2
8	TS-1551041	Lock Washer	M6	7
9	TS-1503051	Socket Hd Cap Screw	M6-1.0 x 20L	3
10	TS-1534042	Phillips Pan Hd Machine Screw	M6-1.0 x 12L	2
12	701-162B	Chuck Access Cover		1
13	701-156B	Head		1
14	701-172B	Locking Handle	M8-1.25 x 30L	1
15	701-176B	Bushing	I.D. 5/8 IN	1
18	701-170B	Chuck with key		1
	701-143NCA	Cylinder Assembly		1
19	701-144N	Cylinder Fitting		2
20	701-143N	Cylinder		1
21	6012290	E-Retaining Ring	ETW-7	2
22	701-153B	Handle		1
23	701-155B	Handle Grip		1
24	701-150B	Gib		1
25	TS-1523071	Soc Hd Set Screw	M6 -1.0 x 25L	3
26	TS-1540041	Hex Nut	M6-1.0P	3
27	701-173B	Bushing Spacer		2
28	F011901	Wave Washer	WW-5	1
29	F005365L	Socket Hd Cap Screw w/thrdlckr	M5-0.8 x 16L	1
30	F012100	Roll Pin	4 x 25L	4
31	701-130B	Knob	16 x 15L	2
32	F006044	C-Retaining Ring Ext.	STW-16	2
33	F006091	E-Retaining Ring	ETW-12	2
34	701-125B	Gear		1
35	TS-1503031	Socket Hd Cap Screw	M6-1.0 x 12L	2
36	701-141B	Rack		1
37	701-126B	Shaft		1
38	F006047	C-Retaining Ring Ext.	STW-20	1
39	701-149B	Handle Hub		1
40	23011063	Spring		1
41	TS-1550041	Flat Washer	6 x 19 x 1.6T	1
42	701-146B	Knob	M6-1.0 x 10L	1
43	F012078	Roll Pin	6 x 20L	1
44	701-154B	Lock Handle	M6-1.0 x 12L	1
45	701-180B	Chisel Sharpening Cone		1
46	TS-2276081	Socket Hd Set Screw	M6-1.0 x 8L	2
49	701-139B	Tool Tray		1
50	TS-1502031	Socket Hd Cap Screw	M5-0.8 x 12L	2

Index No.	Part No.	Description	Size	Qty
51	701-136B	Column		1
52	TS-1504061	Socket Hd Cap Screw	M8-1.25 x 30L	4
53	TS-1551061	Lock Washer	M8	4
54	TS-1550061	Flat Washer	8.5 x 16 x 1.5T	5
55	701-131B	Depth Stop		1
57	701-133B	Locking Handle	M8-1.25 x 65L	1
58	701-120B	Post		1
59	701-123B	Knob		1
60	701-121B	Work Hold-Down		1
61	701-122B	Knob	M6-1.0x 23L	1
62	701-119B	Cam Handle		2
63	701-117B	Bolt	M8-1.25 x 15.5L	2
64	TS-1550071	Flat Washer	10.2 x 23 x 2T	2
65	701-114B	Fence		1
67	701-103B	T-Nut	M8-1.25	2
68	TS-1503041	Socket Hd Cap Screw	M6-1.0 x 16L	2
69	701-112B	Bar		1
70	701-111B	Rack		1
71	TS-1533042	Phillips Pan Hd Machine Screw	M5-0.8 x 12L	2
72	701-101B	Base		1
73	701-107B	Knob	M8-1.25	2
74	701-106B	Bushing		2
75	701-108B	Roller		2
76	TS-1550061	Flat Washer	8.2 x 23 x 2T	2
77	701-105B	Slide Plate		2
78	701-104B	Hex Cap Screw (Special)	M8-1.25 x 45L	2
79	23011020	Chuck Extension Adapter		1
80	701-177B	Bushing	I.D. 3/4 IN	1
81	6294204B	Chuck Key		1

Wiring Diagram for 701 Mortiser

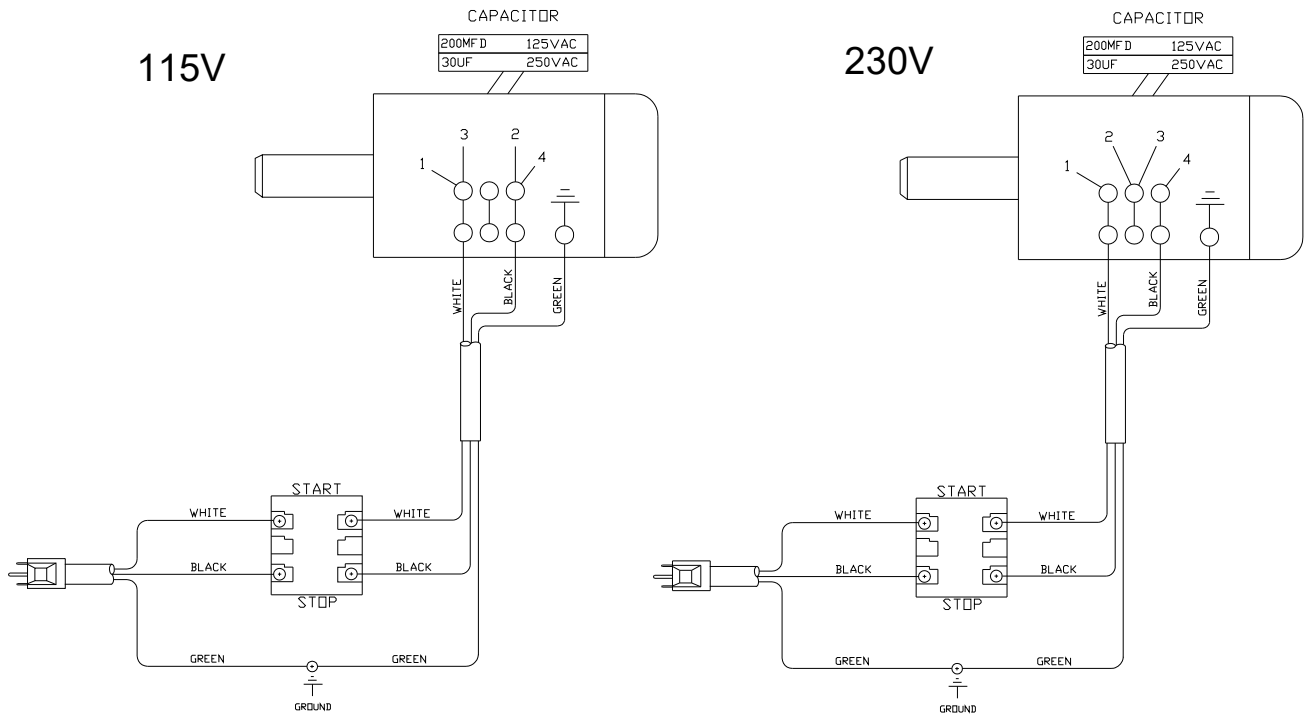

Optional Accessories

Optional accessories can be purchased by calling the service department at the number below.

1791312 701-RB Riser Block Kit

Ordering Replacement Parts

Replacement parts are listed on the following pages. To order parts or reach our service department, call 1-800-274-6848 Monday through Friday, 8:00 a.m. to 5:00 p.m. CST. Having the Model Number and Serial Number of your machine available when you call will allow us to serve you quickly and accurately.

Non-proprietary parts, such as fasteners, can be found at local hardware stores, or may be ordered from Powermatic. Some parts are shown for reference only, and may not be available individually.

Dimensions for 701 with premium chisels mounted

(Chisel and bit sets purchased separately)

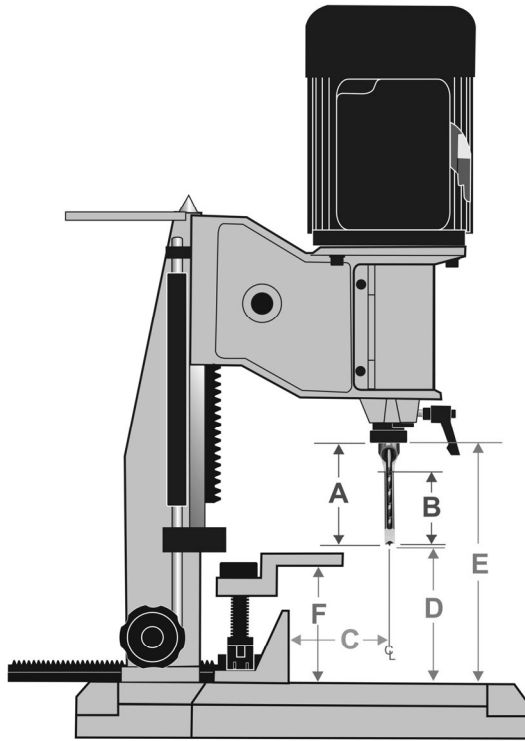

Powermatic 701 Mortiser with Premium Chisels		1791091 1/4" chisel ¹	1791092 5/16" chisel	1791093 3/8" chisel	1791094 1/2" chisel	1791095 3/4" chisel
A	Total Chisel Length (installed)	3-21/32"	3-7/8"	3-7/8"	3-7/8"	5-13/16"
B	Useful Chisel Plunge	1-13/16"	2-1/8"	2-3/4"	3-5/32"	5"
C	Maximum Chisel Centerline to Fence	4-3/8"	4-3/8"	4-3/8"	4-3/8"	4-3/8"
D	Maximum Working Clearance ²	4-29/32"	4-11/16"	4-11/16"	4-11/16"	2-3/4"
E	Maximum Total Clearance	8-5/8"	8-5/8"	8-5/8"	8-5/8"	8-5/8"
F	Capacity under Hold-Down	5"	5"	5"	5"	5"
	Bushing size (I.D.) used	3/4"	3/4"	3/4"	3/4"	3/4"

¹ Chisel size refers to dimension of square hole produced by the chisel.

² Bit protrusion of 1/16" is assumed.

This page intentionally left blank.

This page intentionally left blank.



427 New Sanford Road
LaVergne, Tennessee 37086
Phone: 800-274-6848
www.powermatic.com