

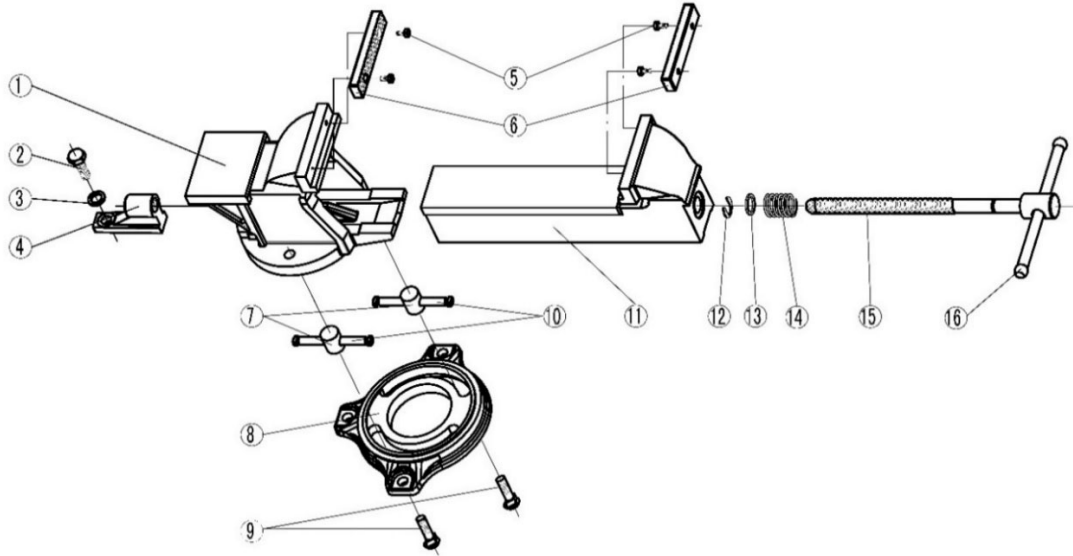

#11104, 11105, 11106 General-Purpose Bench Vice



Replacement parts

ITEM	DESCRIPTION	REQ'D QTY.	STOCK NO.		
			11104	11105	11106
			PART NO. <i>(size specifications in parentheses)</i>		
1	Stationary Body	1			
	Spindle Nut w/Bolt and Washer (#2,3,4)	1	11104-2	11105-2	11106-2
2	Hexagon Head Bolt		TS-1490041 (M8x25)	TS-1491041 (M10x30)	TS-1491041 (M10x30)
3	Spring Washer		TS-2361081 (8mm)	TS-2361101 (10mm)	TS-2361101 (10mm)
4	Spindle Nut				
	Serrated Jaw Inserts (#5,6 = 2 jaws, 4 screws)	1 set	11104S41	11105S41	11106S41
5	Jaw Screw (set of 4)				
6	Serrated Jaw Inserts (set of 2)				
	Lock Bolt and Nut (#7,9,10) – 1 set	2 sets	11104S51	11105-7	11106-49
7	Locking Nut				
8	Base	1			
9	Square Head Bolt				
10	T-Locking Bar				
11	Moving Body	1			
	Spring/Washer/Retaining Ring (#12,13,14)	1	11104S25	11105S25	11106-12
12	Retaining Ring				
13	Washer				
14	Spring				
	Spindle Assembly (#15,16)	1	11104S23	11105S23	11106-15
15	Spindle				
16	Handle				

To order parts or reach our service department, call 1-800-274-6848 Monday through Friday, 8:00 a.m. to 5:00 p.m. CST. Having the Model Number and Serial Number of your tool available when you call will allow us to serve you quickly and accurately. Some parts are shown for reference only, and may not be available individually.

Specifications

Stock no.	11104	11105	11106
Jaw width	4 in.	5 in.	6 in.
Maximum opening	3 in.	4 in.	5 in.
Throat depth	2-1/4 in.	2-1/2 in.	3 in.
Base swivel	120 deg.	120 deg.	120 deg.
Net weight, approximate	16 lbs.	27 lbs.	39 lbs.



See reverse side for important safety instructions.

WILTON

427 New Sanford Road
LaVergne, Tennessee 37086
Ph.: 800-274-6848
www.wiltontools.com

Part No. M-11104

Edition 1 10/2019

Copyright © 2019 WILTON, a Division of JPW Industries, Inc.



IMPORTANT SAFETY INSTRUCTIONS

- Misuse of vise can cause serious injury to eyes, hands, limbs, etc.
- To ensure safety, vise must be set up and used properly.
- Before setting up and using, read, understand, and follow all instructions as outlined below.

When setting up vise:

- Use proper size bolts, nuts, lock and flat washers, in all base mounting Holes. Never weld base of vise to any metal object.
- Only hand-tighten swivel base lock down nuts at the sides of the vise.
- Never use a pipe extension to tighten lock nut handles; this can cause the handles to bend and overstress the lock down bolts.
- Make sure the bench top to which the vise is mounted is properly secured.

When using vise:

- Always use vise of proper size and capacity to hold work object.
- Never use a hammer, pipe extension or cheater bar on spindle handle of vise.
- Never unscrew moveable jaw beyond the maximum specified opening of the vise.
- Never use vise as a press for assembly or disassembly of objects.
- Always wear eye and face protection when striking vise-held objects or when using power tools with a vise.
- NOTE: The spindle handle ("tommy bar") has been engineered to bend if excessive clamping pressure is applied, to prevent potential damage to vise.

 **WARNING:** This product can expose you to chemicals including lead which is known to the State of California to cause cancer and birth defects or other reproductive harm. For more information go to <http://www.p65warnings.ca.gov>.



CONSIGNES DE SECURITE IMPORTANTES

- Une utilisation incorrecte, de l'étau peut entraîner des blessures graves aux yeux aux mains et a d'autres parties du corps.
- Pour garantir la sécurité, l'étau doit être installé et utilisé correctement.
- Avant installation et utilisation, lisez, veillez à bien comprendre et suivre toutes les instructions telles qu'elles sont données de chaque cote de cette étiquette.

Installation de l'étau:

- Pour bloquer la base de l'étau, Utilisez des écrous, boulons et rondelles de la bonne taille dans tous les trous de fixation. ne jamais souder la base de l'étau à un objet métallique quelconque.
- Pour un étau a base tournante, ne serrer qu'avec les doigts les poignées des contre-écrous sur les cotes de l'étau.
- Ne jamais utiliser une rallonge pour serrer les poignées des contre-écrous-cela pourrait tordre les poignées.
- Assurez-vous que l'étau sur lequel est monté l'étau est correctement fixé.

Utilisation de l'étau:

- Toujours utiliser un étau de taille et de capacité appropriées pour tenir l'objet de travail.
- Ne jamais utiliser un marteau, une rallonge ni tout autre outil permettant de faire levier sur la poignée de l'étau.

- Ne jamais dévisser le mors au-delà de l'ouverture maximum spécifiée de l'étau.
- Le jamais utiliser l'étau pour enfoncer un objet dans un autre ou l'en faire sortir.
- Toujours porter des lunettes et un masque de protection pour frapper sur un objet ou utiliser un outillage électrique avec un étau.
- REMARQUE: La poignée de la broche («barre de serrage») a été conçue pour se plier si une pression de serrage excessive est appliquée, afin d'éviter tout dommage potentiel à l'étau.



AVERTISSEMENT: Ce produit peut vous exposer à des produits chimiques, y compris le plomb qui est connu par l'État de Californie pour causer le cancer et des malformations congénitales ou d'autres problèmes de reproduction. Pour plus d'informations, visitez <http://www.p65warnings.ca.gov>.



INSTRUCCIONES DE SEGURIDAD IMPORTANTES

- El uso indebido del tornillo de banco puede causar lesiones graves en los ojos, en las manos y en otras partes del cuerpo.
- Para asegurar la seguridad, el tornillo de banco debe configurarse y utilizarse de forma debida.
- Antes de configurar y usar-lea, entienda y siga todas las instrucciones indicadas en ambos lados de la etiqueta.

Al configurar el tornillo de banco:

- Para sujetar la base del tornillo de banco, use tuercas, pernos y arandelas de presión del tamaño adecuado en todos los agujeros de montaje. No suelde nunca la base del tornillo de banco a ningún objeto de metal.
- Para el tornillo de banco de base giratoria, apriete solamente a mano las palancas de las contratuercas en los lados del tornillo de banco.
- No use nunca un tubo de extensión para apretar las palancas en las contratuercas esto puede hacer que doblen las palancas.
- Asegúrese de que la parte superior del banco donde está montado el tornillo de banco esté bien asegurada.

Al usar el tornillo de banco:

- Use siempre un tornillo de banco del tamaño y de la capacidad adecuados para sujetar el objeto de trabajo.
- No use nunca un martillo, un tubo de extensión o un Alargador en la palanca del uso del tornillo de banco.
- No desatornille nunca la mordaza móvil mas allá de la abertura especificada máxima del tornillo de banco.
- No use nunca el tornillo de banco para encajar un objeto en otro objeto o desprenderlo de otro objeto.
- Lleve siempre protectores de los ojos y la cara al golpear o usar herramientas as con un tornillo de banco.
- NOTA: El mango husillo ("bar Tommy") ha sido diseñado para doblarse si se aplica una presión de apriete excesivo, para evitar el daño potencial a tornillo de banco.



ADVERTENCIA: Este producto puede exponerlo a productos químicos, incluido de plomo, que en el estado de California se conoce como causantes de cáncer y defectos de nacimiento u otros daños reproductivos. Para obtener más información, vaya a <http://www.p65warnings.ca.gov>.



The Wilton® lifetime warranty is for the product's lifetime with no end date. This warranty covers manufacturer's defect only and does not cover failures due directly or indirectly to misuse, abuse, negligence or accidents, normal wear-and-tear, improper repair, alterations or lack of maintenance. For more information, please visit wiltontools.com.

How to Get Technical Support

Please contact Technical Service by calling 1-800-274-6846. **Please note that you will be asked to provide proof of initial purchase when calling.** If a product requires further inspection, the Technical Service representative will explain and assist with any additional action needed. Wilton has Authorized Service Centers located throughout the United States. For the name of an Authorized Service Center in your area call 1-800-274-6846 or use the Service Center Locator on the Wilton website.

Wilton sells through distributors only. The specifications listed in Wilton printed materials and on official Wilton branded website are given as general information and are not binding. Wilton reserves the right to effect at any time, without prior notice, those alterations to parts, fittings, and accessory equipment which they may deem necessary for any reason whatsoever.

NOTE: Wilton is a division of JPW Industries, Inc. References in this document to Wilton also apply to JPW Industries, Inc., or any of its successors in interest to the Wilton brand.