

# READ THIS FIRST

**Grizzly**  
**Industrial, Inc.**®

Models H2933, H2934,  
G0447, & G0581

**\*\*\*IMPORTANT UPDATE\*\*\***

For Machines Mfd. Since January, 2014  
and Owner's Manual Revised October, 2005

For questions or help with this product contact Tech Support at (570) 546-9663 or [techsupport@grizzly.com](mailto:techsupport@grizzly.com)

The following changes were made to this machine since the owner's manual was printed:

- Obtained CSA certification meeting CSA C22.2 #105-1953 and UL 987-7th standards.
- Changed transformer, contactors, overload relays, terminal blocks, and wiring.
- Changed circuit requirements.
- Replaced oscillation diaphragm assembly with an air cylinder.

**Note:** At the top of each page is a note that indicates which page it replaces in the original manual. On the parts list, the new parts are designated with a "V2".

Aside from this information, all other content in the owner's manual applies and **MUST** be read and understood for your own safety. **IMPORTANT: Keep this update with the owner's manual for future reference.** For questions or help, contact our Tech Support at (570) 546-9663 or [techsupport@grizzly.com](mailto:techsupport@grizzly.com).



COPYRIGHT © JUNE, 2010 BY GRIZZLY INDUSTRIAL, INC., REVISED DECEMBER, 2016 (MN)

**WARNING: NO PORTION OF THIS MANUAL MAY BE REPRODUCED IN ANY SHAPE  
OR FORM WITHOUT THE WRITTEN APPROVAL OF GRIZZLY INDUSTRIAL, INC.**

#TS12965 PRINTED IN TAIWAN

Replaces Page 72

# Main Electrical Panel and Controls Diagram

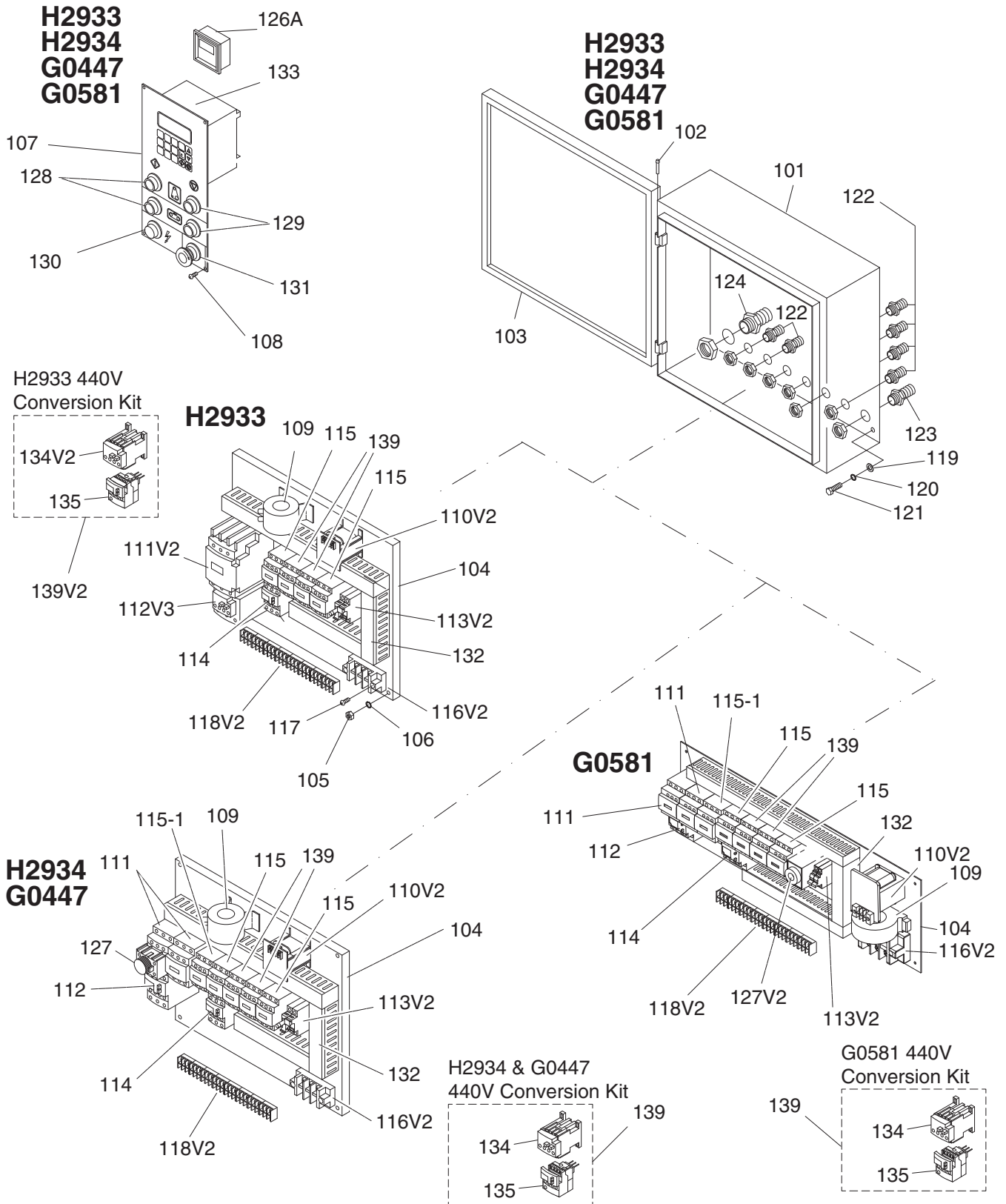

# Replaces Page 73

## Electrical Parts List

REF	PART #	DESCRIPTION
101	PH29338101	ELECTRICAL CONTROL BOX (H2933)
101	PH29348101	ELECTRICAL CONTROL BOX (G0447/H2934)
101	P05818101	ELECTRICAL CONTROL BOX (G0581)
102	PH29338102	HINGE
103	PH29348103	DOOR (G0447/H2934)
103	P05818103	DOOR (G0581)
103	PH29338103	DOOR (H2933)
104	PH29338104	BASE PLATE (H2933)
104	PH29348104	BASE PLATE (G0447/H2934)
104	P05818104	BASE PLATE (G0581)
105	PN05	HEX NUT 1/4-20
106	PLW02	LOCK WASHER 1/4
107	PH29338107	CONTROL PANEL
108	PS07M	PHLP HD SCR M4-.7 X 8
109	PH29338109	CURRENT SENSOR
110V2	PH29338110V2	TRANSFORMER V2.03.10
111	PH29348111	CONTACTOR SCHN LC1D38 220V (G0447/G0581/H2934)
111V2	PH29338111V2	CONTACTOR SCHN LC1D40A 220V V2.04.13 (H2933)
112	PH29348112	OL RELAY SCHN LR3D32 23-32A (G0447/H2934)
112	P05818112	OL RELAY SCHN LR3D35 30-38A (G0581)
112V3	P0539012V3	OL RELAY SCHN LRD340 30-40A V3.04.13 (H2933)
113V2	PH29338113V2	FUSE 4A V2.03.10
114	PH29338114	OL RELAY SCHN LR3D08 2.5-4A (G0447/H2933/H2934)
114	P05818114	OL RELAY SCHN LR3D12 5.5-8A (G0581)

REF	PART #	DESCRIPTION
115	PH29338115	CONTACTOR SCHN LC1D09 220V
115-1	PH29348115-1	CONTACTOR SCHN LC1D25 220V
116V2	PH29348116V2	GROUND TERMINAL V2.03.10 (G0447/H2934)
116V2	P05818116V2	GROUND TERMINAL V2.03.10 (G0581)
116V2	PH29338116V2	GROUND TERMINAL V2.03.10 (H2933)
117	PS51M	PHLP HD SCR M4-.7 X 30
118V2	PH29338118V2	TERMINAL PLATE V2.03.10
119	PW06	FLAT WASHER 1/4
120	PLW02	LOCK WASHER 1/4
121	PB19	HEX BOLT 1/4-20 X 1/2
122	PH29338122	PU CONNECTOR 1/2"
123	PH29338123	PU CONNECTOR 3/4"
124	PH29338124	CABLE CONNECTOR 1"
126A	PH29338126A	DIGITAL AMP METER N/S
127	PH29348127	START DELAY LADS2 (G0447/H2934)
127V2	P05818127V2	START DELAY LSD V2.03.10 (G0581)
128	PH29338128	START SWITCH
129	PH29338129	STOP SWITCH
130	PH29338130	POWER INDICATION LIGHT
131	PH29338131	EMERCENGY STOP SWITCH
132	PH29338132	WIRE COLUMN (G0447/H2933/H2934)
132	P05818132	WIRE COLUMN (G0581)
133	PH29338133	COMPUTER
139	PH29338139	CONTACTOR SCHN LC1D09 220V W/LOCK

### H2933 440V Conversion Kit

139V2	PH29339139V2	440V CONVERSION KIT
134V2	PH29338134V2	OL RELAY SCHN LR3D325 17-25A V2.04.13
135	PH29338135	OL RELAY SCHN LR3D07 1.6-2.5A

### H2934 440V Conversion Kit

139	PH29349139	440V CONVERSION KIT
134	PH29348134	OL RELAY SCHN LR3D21 12-18A
135	PH29338135	OL RELAY SCHN LR3D07 1.6-2.5A

### G0447 440V Conversion Kit

139	PH29349139	440V CONVERSION KIT
134	PH29348134	OL RELAY SCHN LR3D21 12-18A
135	PH29338135	OL RELAY SCHN LR3D07 1.6-2.5A

### G0581 440V Conversion Kit

139	P05819139	440V CONVERSION KIT
134	PH29348134	OL RELAY SCHN LR3D21 12-18A
135	PH29338114	OL RELAY SCHN LR3D08 2.5-4A



*Replaces Page 10*  
**SECTION 1: SAFETY**

---

## **For Your Own Safety, Read Instruction Manual Before Operating This Machine**

The purpose of safety symbols is to attract your attention to possible hazardous conditions. This manual uses a series of symbols and signal words intended to convey the level of importance of the safety messages. The progression of symbols is described below. Remember that safety messages by themselves do not eliminate danger and are not a substitute for proper accident prevention measures. Always use common sense and good judgment.



Indicates an imminently hazardous situation which, if not avoided, **WILL** result in death or serious injury.



Indicates a potentially hazardous situation which, if not avoided, **COULD** result in death or serious injury.



Indicates a potentially hazardous situation which, if not avoided, **MAY** result in minor or moderate injury. It may also be used to alert against unsafe practices.

***NOTICE***

This symbol is used to alert the user to useful information about proper operation of the machine.

## **Safety Instructions for Machinery**



**OWNER'S MANUAL.** Read and understand this owner's manual **BEFORE** using machine.

**TRAINED OPERATORS ONLY.** Untrained operators have a higher risk of being hurt or killed. Only allow trained/supervised people to use this machine. When machine is not being used, disconnect power, remove switch keys, or lock-out machine to prevent unauthorized use—especially around children. Make workshop kid proof!

**DANGEROUS ENVIRONMENTS.** Do not use machinery in areas that are wet, cluttered, or have poor lighting. Operating machinery in these areas greatly increases the risk of accidents and injury.

**MENTAL ALERTNESS REQUIRED.** Full mental alertness is required for safe operation of machinery. Never operate under the influence of drugs or alcohol, when tired, or when distracted.

**ELECTRICAL EQUIPMENT INJURY RISKS.** You can be shocked, burned, or killed by touching live electrical components or improperly grounded machinery. To reduce this risk, only allow qualified service personnel to do electrical installation or repair work, and always disconnect power before accessing or exposing electrical equipment.

**DISCONNECT POWER FIRST.** Always disconnect machine from power supply **BEFORE** making adjustments, changing tooling, or servicing machine. This prevents an injury risk from unintended startup or contact with live electrical components.

**EYE PROTECTION.** Always wear ANSI-approved safety glasses or a face shield when operating or observing machinery to reduce the risk of eye injury or blindness from flying particles. Everyday eyeglasses are **NOT** approved safety glasses.



## **WARNING**

**WEARING PROPER APPAREL.** Do not wear clothing, apparel or jewelry that can become entangled in moving parts. Always tie back or cover long hair. Wear non-slip footwear to reduce risk of slipping and losing control or accidentally contacting cutting tool or moving parts.

**HAZARDOUS DUST.** Dust created by machinery operations may cause cancer, birth defects, or long-term respiratory damage. Be aware of dust hazards associated with each workpiece material. Always wear a NIOSH-approved respirator to reduce your risk.

**HEARING PROTECTION.** Always wear hearing protection when operating or observing loud machinery. Extended exposure to this noise without hearing protection can cause permanent hearing loss.

**REMOVE ADJUSTING TOOLS.** Tools left on machinery can become dangerous projectiles upon startup. Never leave chuck keys, wrenches, or any other tools on machine. Always verify removal before starting!

**USE CORRECT TOOL FOR THE JOB.** Only use this tool for its intended purpose—do not force it or an attachment to do a job for which it was not designed. Never make unapproved modifications—modifying tool or using it differently than intended may result in malfunction or mechanical failure that can lead to personal injury or death!

**AWKWARD POSITIONS.** Keep proper footing and balance at all times when operating machine. Do not overreach! Avoid awkward hand positions that make workpiece control difficult or increase the risk of accidental injury.

**CHILDREN & BYSTANDERS.** Keep children and bystanders at a safe distance from the work area. Stop using machine if they become a distraction.

**GUARDS & COVERS.** Guards and covers reduce accidental contact with moving parts or flying debris. Make sure they are properly installed, undamaged, and working correctly **BEFORE** operating machine.

**FORCING MACHINERY.** Do not force machine. It will do the job safer and better at the rate for which it was designed.

**NEVER STAND ON MACHINE.** Serious injury may occur if machine is tipped or if the cutting tool is unintentionally contacted.

**STABLE MACHINE.** Unexpected movement during operation greatly increases risk of injury or loss of control. Before starting, verify machine is stable and mobile base (if used) is locked.

**USE RECOMMENDED ACCESSORIES.** Consult this owner's manual or the manufacturer for recommended accessories. Using improper accessories will increase the risk of serious injury.

**UNATTENDED OPERATION.** To reduce the risk of accidental injury, turn machine **OFF** and ensure all moving parts completely stop before walking away. Never leave machine running while unattended.

**MAINTAIN WITH CARE.** Follow all maintenance instructions and lubrication schedules to keep machine in good working condition. A machine that is improperly maintained could malfunction, leading to serious personal injury or death.

**DAMAGED PARTS.** Regularly inspect machine for damaged, loose, or mis-adjusted parts—or any condition that could affect safe operation. Immediately repair/replace **BEFORE** operating machine. For your own safety, **DO NOT** operate machine with damaged parts!

**MAINTAIN POWER CORDS.** When disconnecting cord-connected machines from power, grab and pull the plug—**NOT** the cord. Pulling the cord may damage the wires inside. Do not handle cord/plug with wet hands. Avoid cord damage by keeping it away from heated surfaces, high traffic areas, harsh chemicals, and wet/damp locations.

**EXPERIENCING DIFFICULTIES.** If at any time you experience difficulties performing the intended operation, stop using the machine! Contact our Technical Support at (570) 546-9663.





# Additional Safety for Wide Belt Sanders

## **WARNING**

Serious injury or death can occur from hands getting trapped between workpiece and conveyor table, getting entangled in rotating parts inside machine, or lacerated by sanding drum. Workpieces thrown by sander can strike nearby operators. Long-term respiratory damage can occur from using sander without proper use of a respirator and an adequate dust collection system. To minimize risk of getting hurt or killed, anyone operating machine **MUST** completely heed hazards and warnings below.

**FEEDING WORKPIECE.** DO NOT place fingers under bottom of workpiece while feeding it into sander. Fingers can become pinched between workpiece and conveyor.

**ENTANGLEMENT HAZARDS.** DO NOT wear loose clothing, gloves, or jewelry, and tie back long hair. Never reach inside operating machine or try clearing jammed workpiece. Keep all guards in place and secure, and all doors closed.

**SANDING DRUM CONTACT.** Rotating sandpaper can remove a large amount of flesh in a few seconds. Keep hands away from rotating sanding drum(s) during operation. Never touch moving sandpaper on purpose.

**WORKPIECE KICKBACK.** A workpiece can be ejected out the front of sander at high rate of speed, and hit operator or bystanders. Never stand in-line with workpiece, never feed more than one workpiece at a time, and always adjust pressure rollers below sanding roller.

**MINIMUM STOCK DIMENSION.** To avoid kick-back, never sand workpieces below minimum specifications listed in **Data Sheet**.

**ADJUSTMENTS/MAINTENANCE.** Make sure machine is turned **OFF**, disconnected from power and air, and all moving parts are completely stopped before doing adjustments or maintenance.

**SANDING DUST.** Sanding creates large amounts of dust and flying chips that can lead to eye injury or respiratory illness. Reduce risk of these hazards by wearing approved eye and respiratory protection when using sander.

**DUST COLLECTION.** Never operate without adequate dust collection system in place and running. Proper dust collection reduces dust in work area, which decreases risk of long-term respiratory damage, but it is not a substitute for using a respirator.

## **WARNING**

Like all machinery there is potential danger when operating this machine. Accidents are frequently caused by lack of familiarity or failure to pay attention. Use this machine with respect and caution to decrease the risk of operator injury. If normal safety precautions are overlooked or ignored, serious personal injury may occur.

## **CAUTION**

No list of safety guidelines can be complete. Every shop environment is different. Always consider safety first, as it applies to your individual working conditions. Use this and other machinery with caution and respect. Failure to do so could result in serious personal injury, damage to equipment, or poor work results.



*Replaces Page 13*  
**SECTION 2: CIRCUIT  
REQUIREMENTS**

---

**Availability**

Before installing the machine, consider the availability and proximity of the required power supply circuit. If an existing circuit does not meet the requirements for this machine, a new circuit must be installed. To minimize the risk of electrocution, fire, or equipment damage, installation work and electrical wiring must be done by an electrician or qualified service personnel in accordance with all applicable codes and standards.

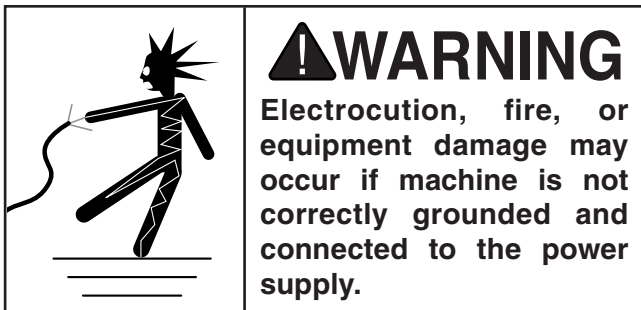

**Full-Load Current Rating**

The full-load current rating is the amperage a machine draws at 100% of the rated output power. On machines with multiple motors, this is the amperage drawn by the largest motor or sum of all motors and electrical devices that might operate at one time during normal operations.

**H2933**

**Full-Load Current Rating at 220V .....40.6A**  
**Full-Load Current Rating at 440V .....20.3A**

**H2934 & G0447**

**Full-Load Current Rating at 220V .....54.6A**  
**Full-Load Current Rating at 440V .....27.3A**

**G0581**

**Full-Load Current Rating at 220V .....70.5A**  
**Full-Load Current Rating at 440V .....35.3A**

The full-load current is not the maximum amount of amps that the machine will draw. If the machine is overloaded, it will draw additional amps beyond the full-load rating.

If the machine is overloaded for a sufficient length of time, damage, overheating, or fire may result—especially if connected to an undersized circuit. To reduce the risk of these hazards, avoid overloading the machine during operation and make sure it is connected to a power supply circuit that meets the requirements in the following section.



## In Addition to Page 13

### Circuit Information

A power supply circuit includes all electrical equipment between the breaker box or fuse panel in the building and the machine. The power supply circuit used for this machine must be sized to safely handle the full-load current drawn from the machine for an extended period of time. (If this machine is connected to a circuit protected by fuses, use a time delay fuse marked D.)

### CAUTION

**For your own safety and protection of property, consult an electrician if you are unsure about wiring practices or electrical codes in your area.**

**Note:** *The circuit requirements listed in this manual apply to a dedicated circuit—where only one machine will be running at a time. If this machine will be connected to a shared circuit where multiple machines will be running at the same time, consult a qualified electrician to ensure that the circuit is properly sized for safe operation.*

### H2933 Circuit Requirements

#### For 220V

This machine is prewired to operate on a 220V power supply circuit that has a verified ground and meets the following requirements:

**Nominal Voltage ..... 220V, 230V, 240V  
Cycle .....60 Hz  
Phase ..... 3-Phase  
Power Supply Circuit ..... 50 Amps**

#### For 440V

This machine can be converted to operate on a 440V power supply (refer to **Voltage Conversion** instructions) that has a verified ground and meets the following requirements:

**Nominal Voltage ..... 440V, 480V  
Cycle .....60 Hz  
Phase ..... 3-Phase  
Power Supply Circuit ..... 30 Amps**

### H2934 & G0447 Circuit Requirements

#### For 220V

This machine is prewired to operate on a 220V power supply circuit that has a verified ground and meets the following requirements:

**Nominal Voltage ..... 220V, 230V, 240V  
Cycle .....60 Hz  
Phase ..... 3-Phase  
Power Supply Circuit ..... 70 Amps**

#### For 440V

This machine can be converted to operate on a 440V power supply (refer to **Voltage Conversion** instructions) that has a verified ground and meets the following requirements:

**Nominal Voltage ..... 440V, 480V  
Cycle .....60 Hz  
Phase ..... 3-Phase  
Power Supply Circuit ..... 40 Amps**

### G0581 Circuit Requirements

#### For 220V

This machine is prewired to operate on a 220V power supply circuit that has a verified ground and meets the following requirements:

**Nominal Voltage ..... 220V, 230V, 240V  
Cycle .....60 Hz  
Phase ..... 3-Phase  
Power Supply Circuit ..... 90 Amps**

#### For 440V

This machine can be converted to operate on a 440V power supply (refer to **Voltage Conversion** instructions) that has a verified ground and meets the following requirements:

**Nominal Voltage ..... 440V, 480V  
Cycle .....60 Hz  
Phase ..... 3-Phase  
Power Supply Circuit ..... 50 Amps**





## In Addition to Page 13

### Connection Type

A permanently connected (hardwired) power supply is typically installed with wires running through mounted and secured conduit. A disconnecting means, such as a locking switch (see following **Figure**), must be provided to allow the machine to be disconnected (isolated) from the power supply when required. This installation must be performed by an electrician in accordance with all applicable electrical codes and ordinances.

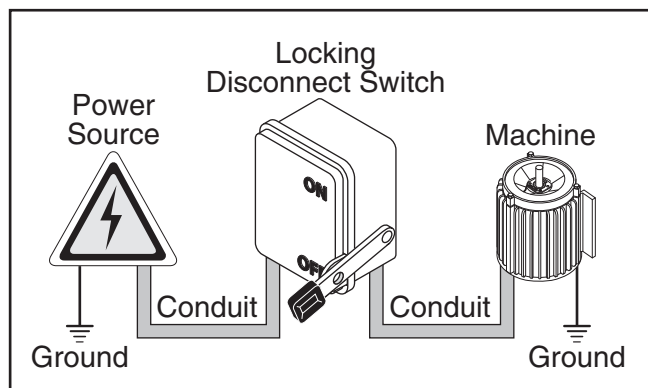

**Figure 6.** Typical setup of a permanently connected machine.

### Grounding Instructions

In the event of a malfunction or breakdown, grounding provides a path of least resistance for electrical current to reduce the risk of electric shock. A permanently connected machine must be connected to a grounded metal permanent wiring system; or to a system having an equipment-grounding conductor. All grounds must be verified and rated for the electrical requirements of the machine. Improper grounding can increase the risk of electric shock!

### **!WARNING**

**Serious injury could occur if you connect the machine to power before completing the setup process. DO NOT connect to power until instructed later in this manual.**

### Extension Cords

Since this machine must be permanently connected to the power supply, an extension cord cannot be used.



# 440V Connection

This machine is prewired for 220V 3-phase power but has the capability of operating on 440V power with a minor conversion. The conversion consists of replacing two overload relays and rewiring each of the three motors.

Contact the Grizzly Order Desk at (800) 523-4777 to purchase the correct 440V conversion kit for your model that includes the necessary two overload relays:

Model	Part Number
H2933.....	PH29339139V2
H2934.....	PH29349139
G0447.....	PH29349139
G0581.....	P05819139

All wiring changes must be inspected by service personnel or a qualified electrician before the machine is connected to the power source. If, at any time during this procedure you need help, call Grizzly Tech Support at (570) 546-9663.

**Note:** When using a phase converter, the power from the manufactured power leg (sometimes called the wild wire) can fluctuate. Connect the manufactured power leg to the S terminal to prevent damage to the transformer. The wire from the S terminal can handle some fluctuation because it goes directly to the motor. The power going to the R and T terminals goes to the transformer and must be consistent to prevent damage.

### To wire the sander to 440V:

1. DISCONNECT MACHINE FROM POWER!
2. Open the electrical box located on the back of the machine.
3. On the transformer, remove the wire connected to the 220V terminal and connect it to the 440V terminal, as shown in **Figures 7**.

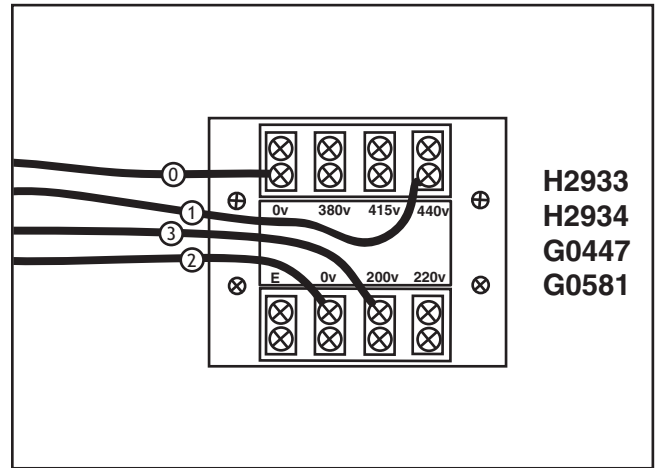

Figure 7. 440V transformer connections.

4. Swap out the applicable overload relay at the locations shown in **Figure 8**, and set the amperage dial to values listed in **Figure 8**.

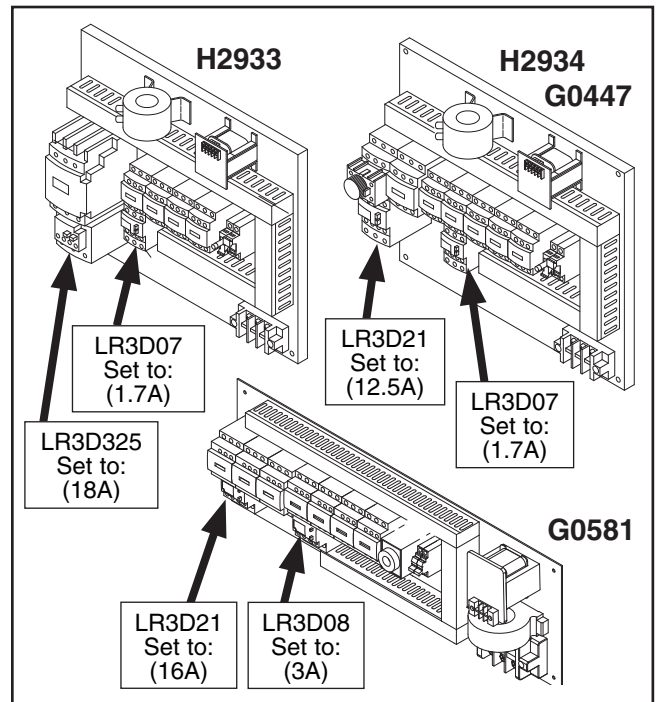

Figure 8. Overload relays for 440V.

5. Wire the sanding belt, conveyor belt, and table elevation motors as shown in the diagrams on **Page 55** of the owner's manual.



Replaces Page 43

# Control Panel Electrical Diagram (H2933/H2934/G0447)

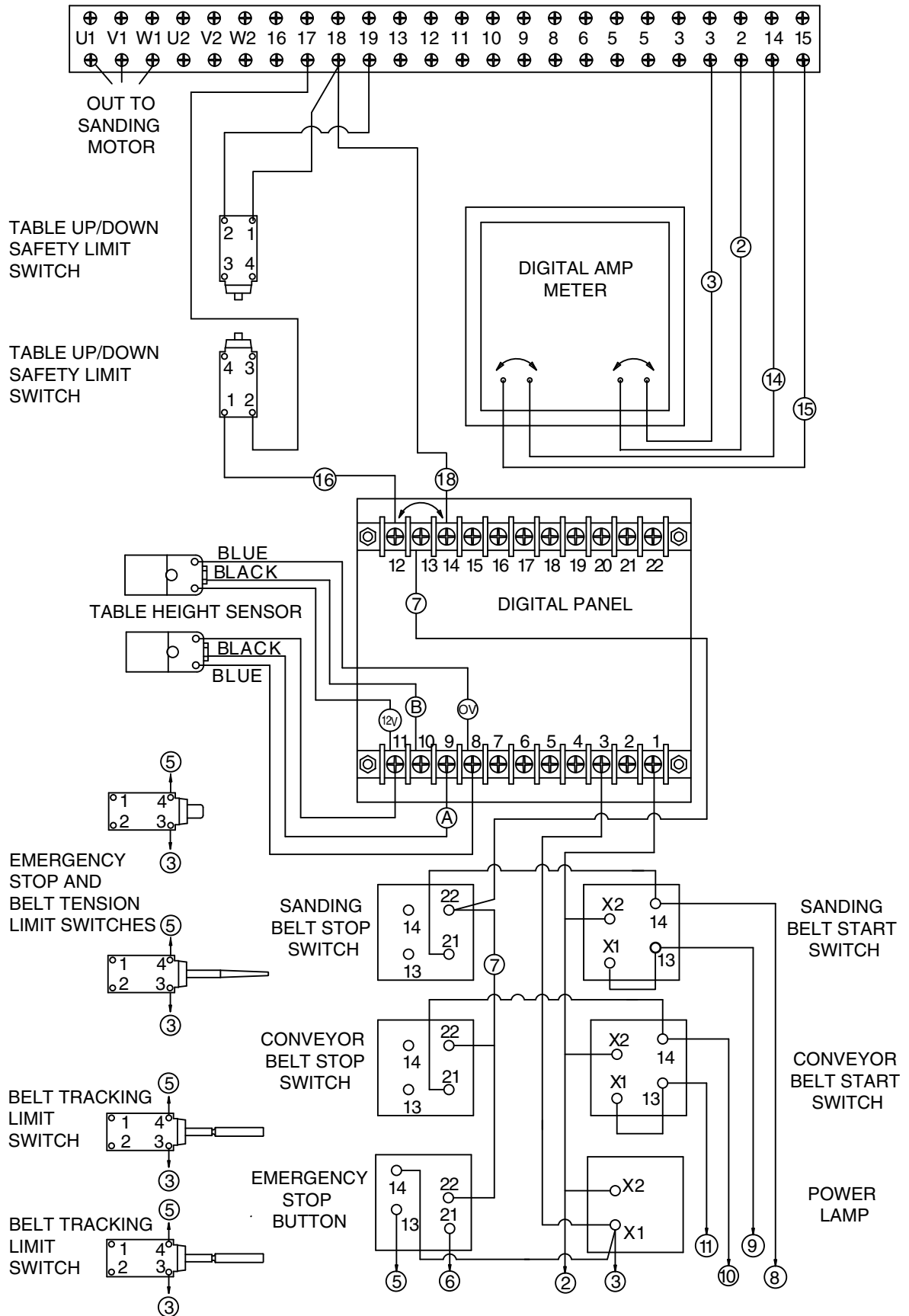

Replaces Page 44

# Control Panel Electrical Diagram (G0581)

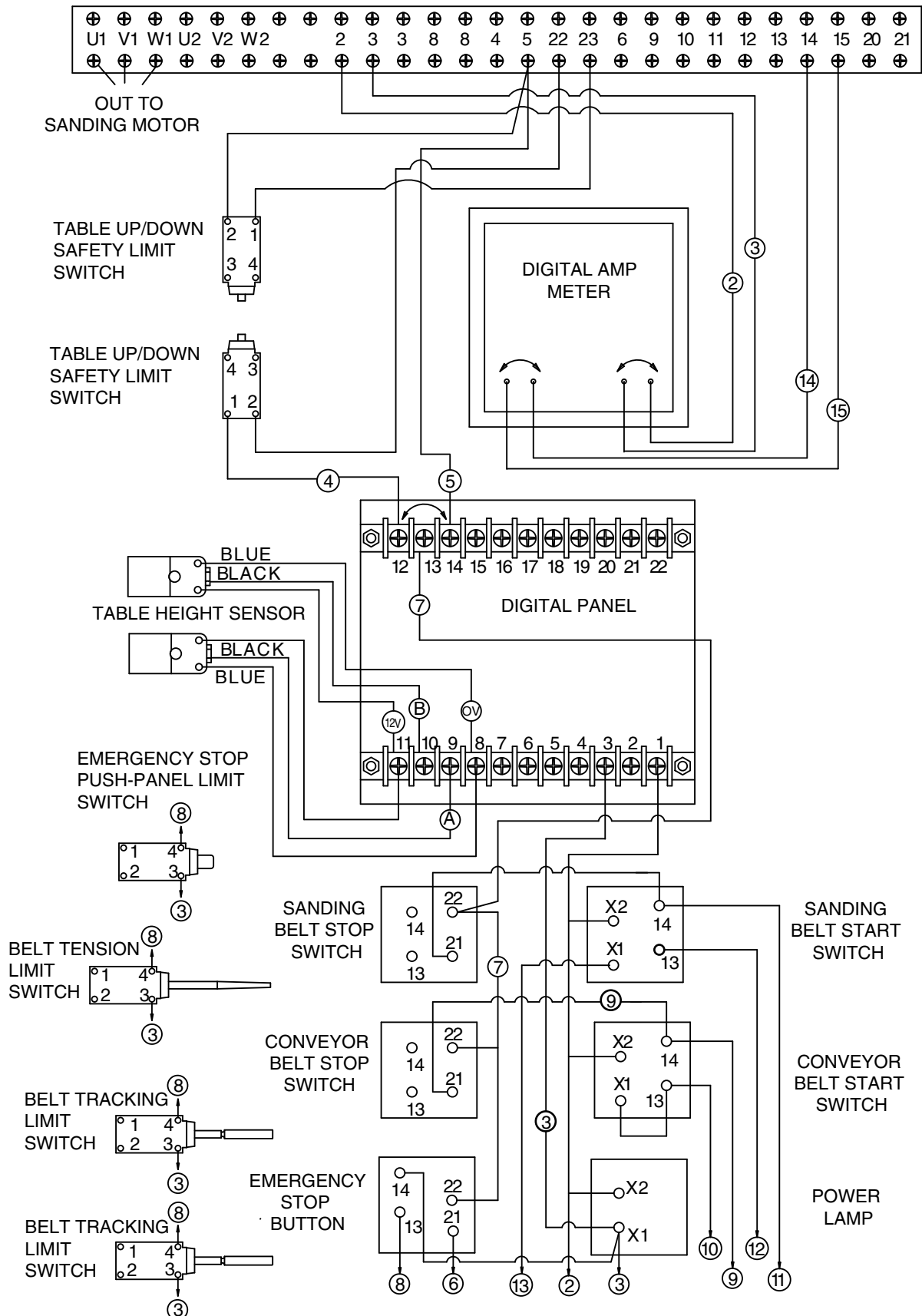

# Electrical Box Wiring Diagram (H2933)

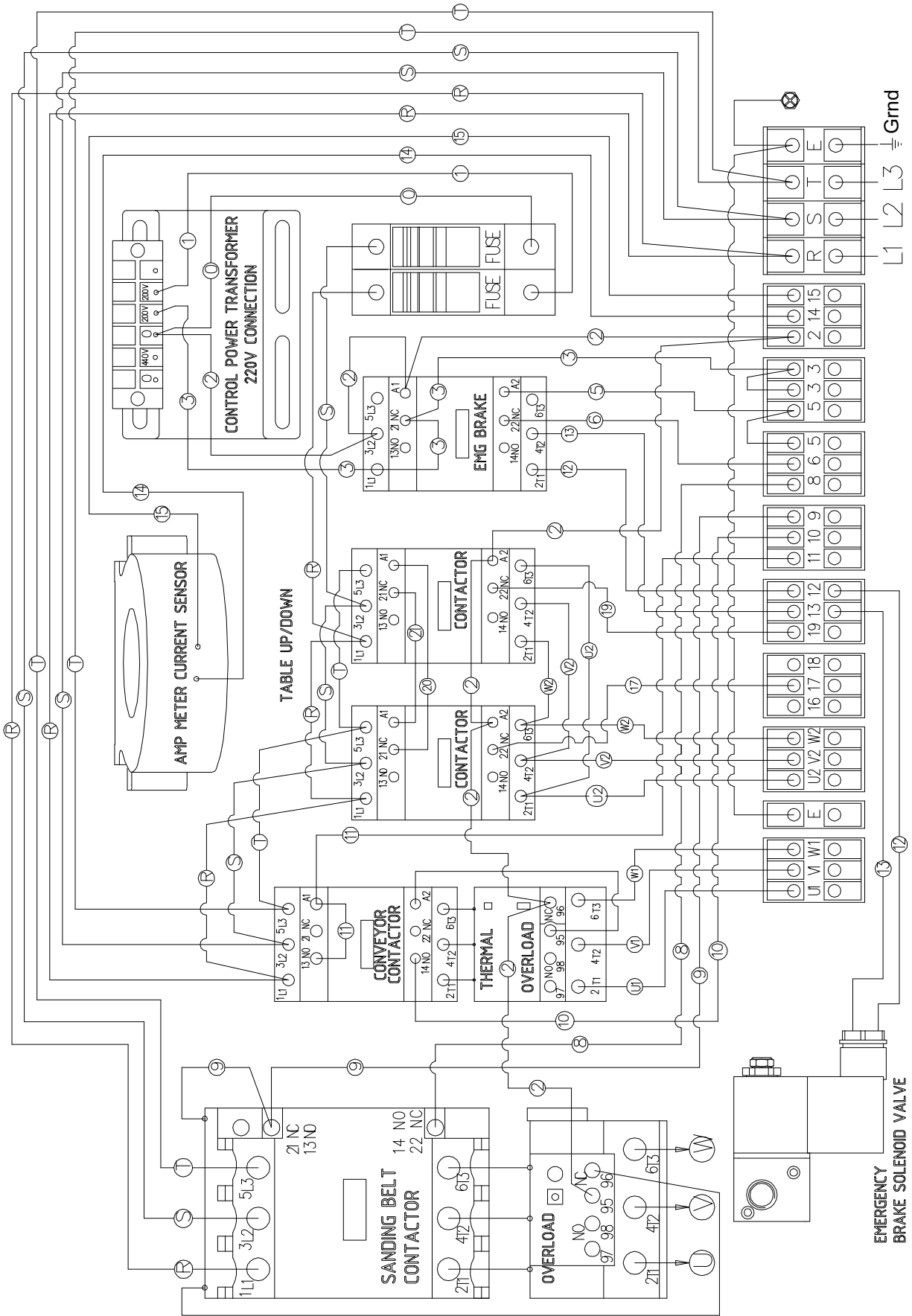



Replaces Page 48

# Electrical Box Wiring Diagram (G0447/H2934)

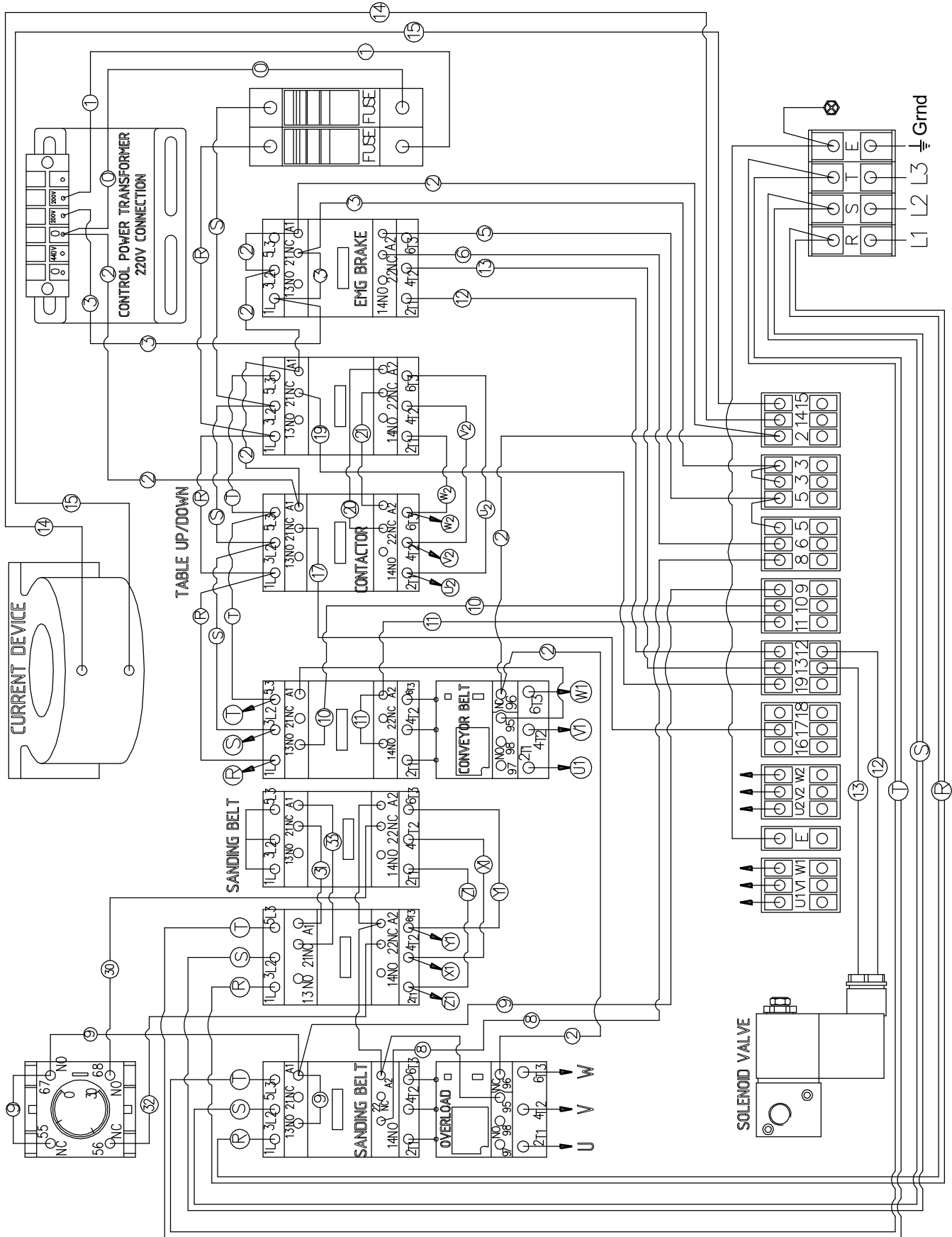

# Electrical Box Wiring Diagram (G0581)

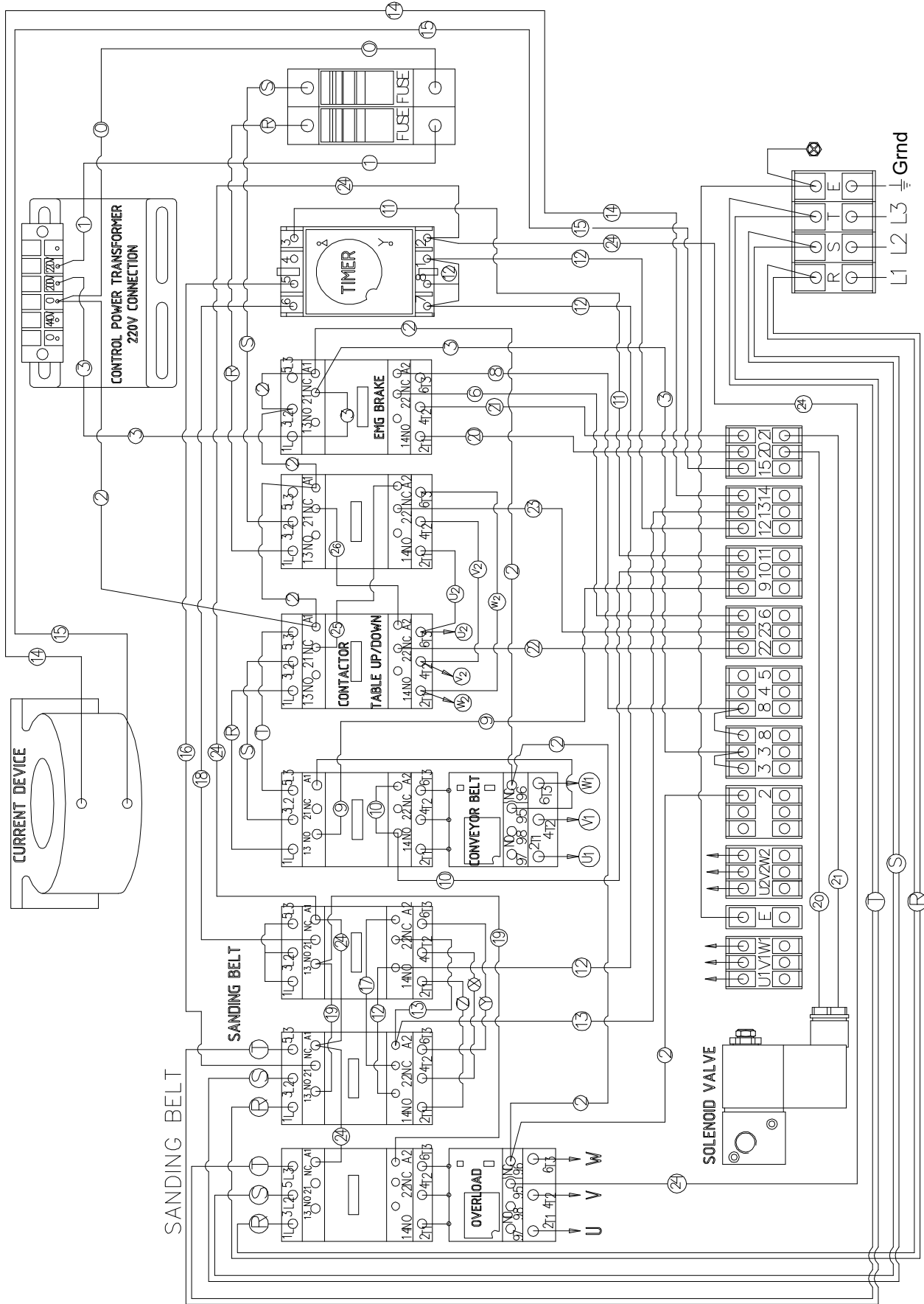

Replaces Page 52

# General Wiring Diagram (H2933)

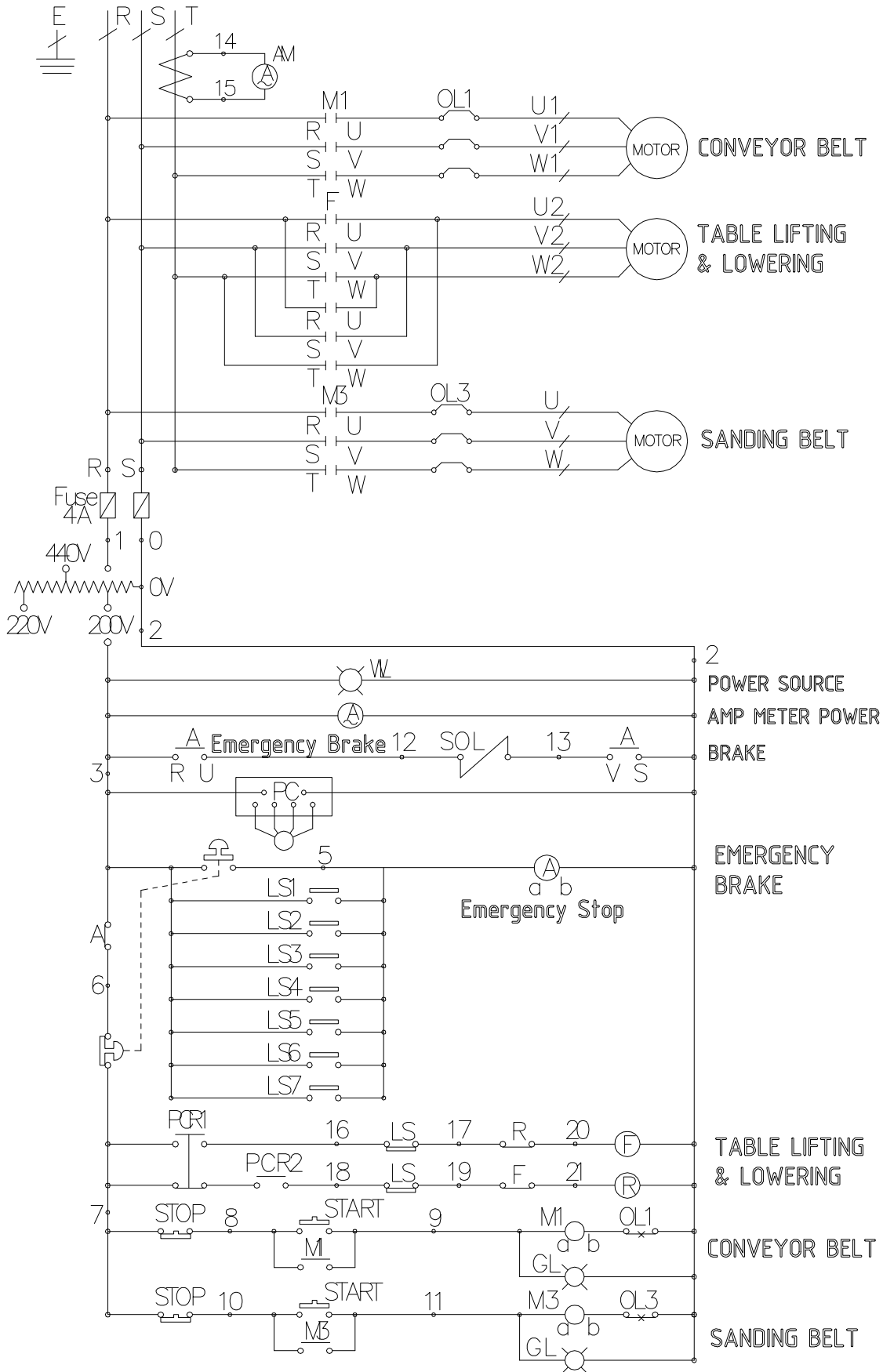

Replaces Page 53

# General Wiring Diagram (G0477/H2934)

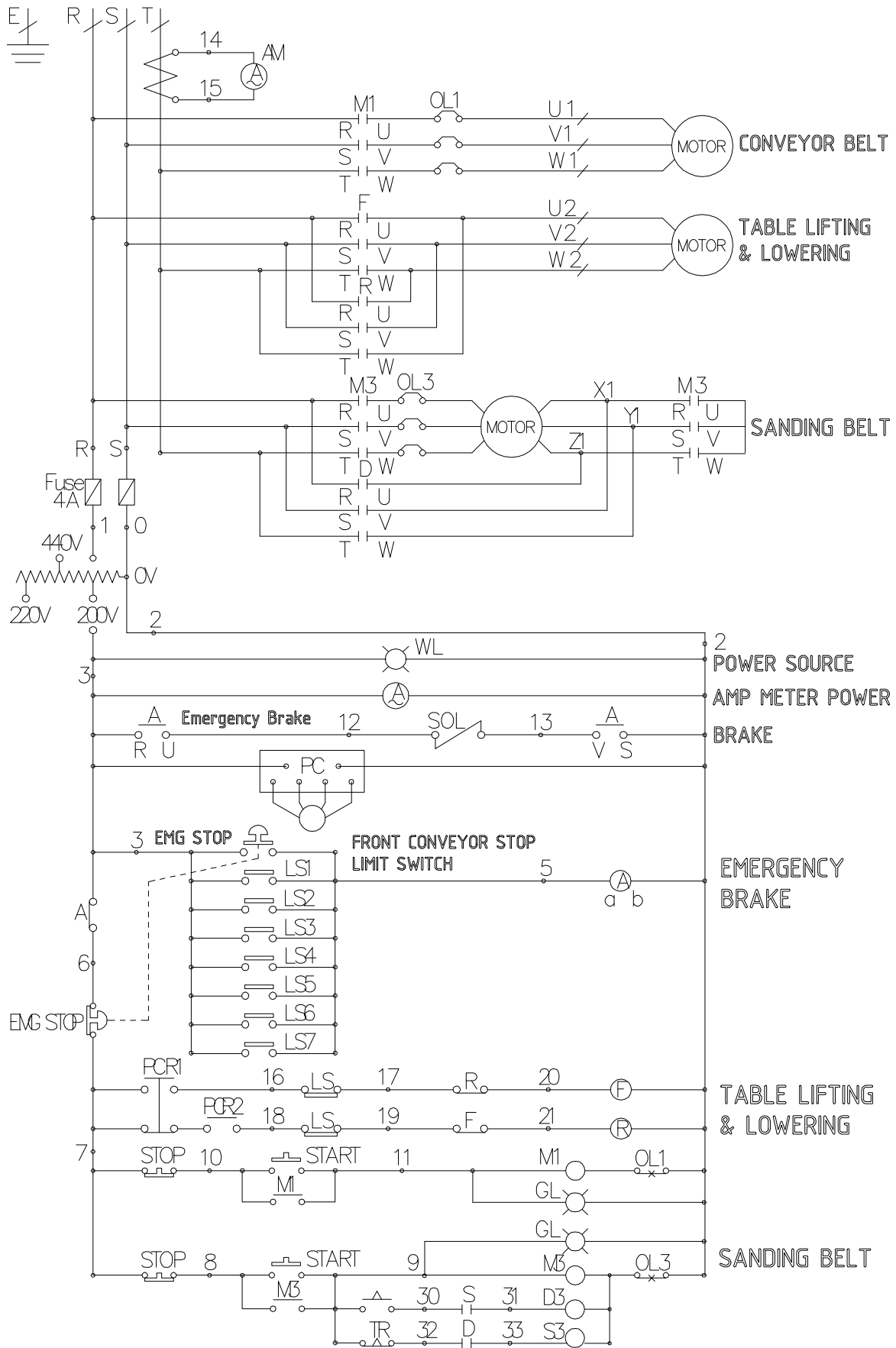

Replaces Page 54

# General Wiring Diagram (G0581)

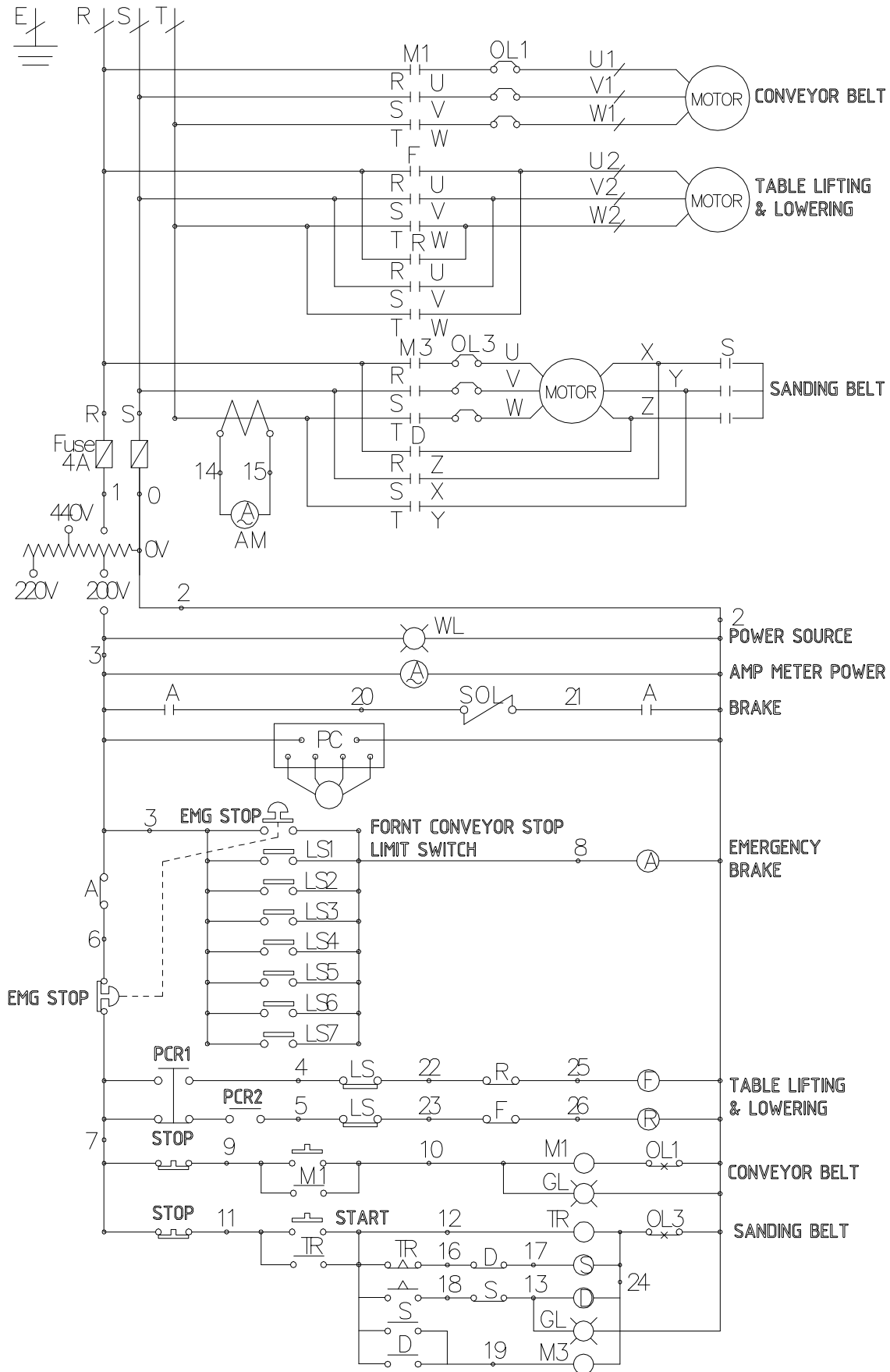



Replaces Page 68

# Upper Roller System Diagram

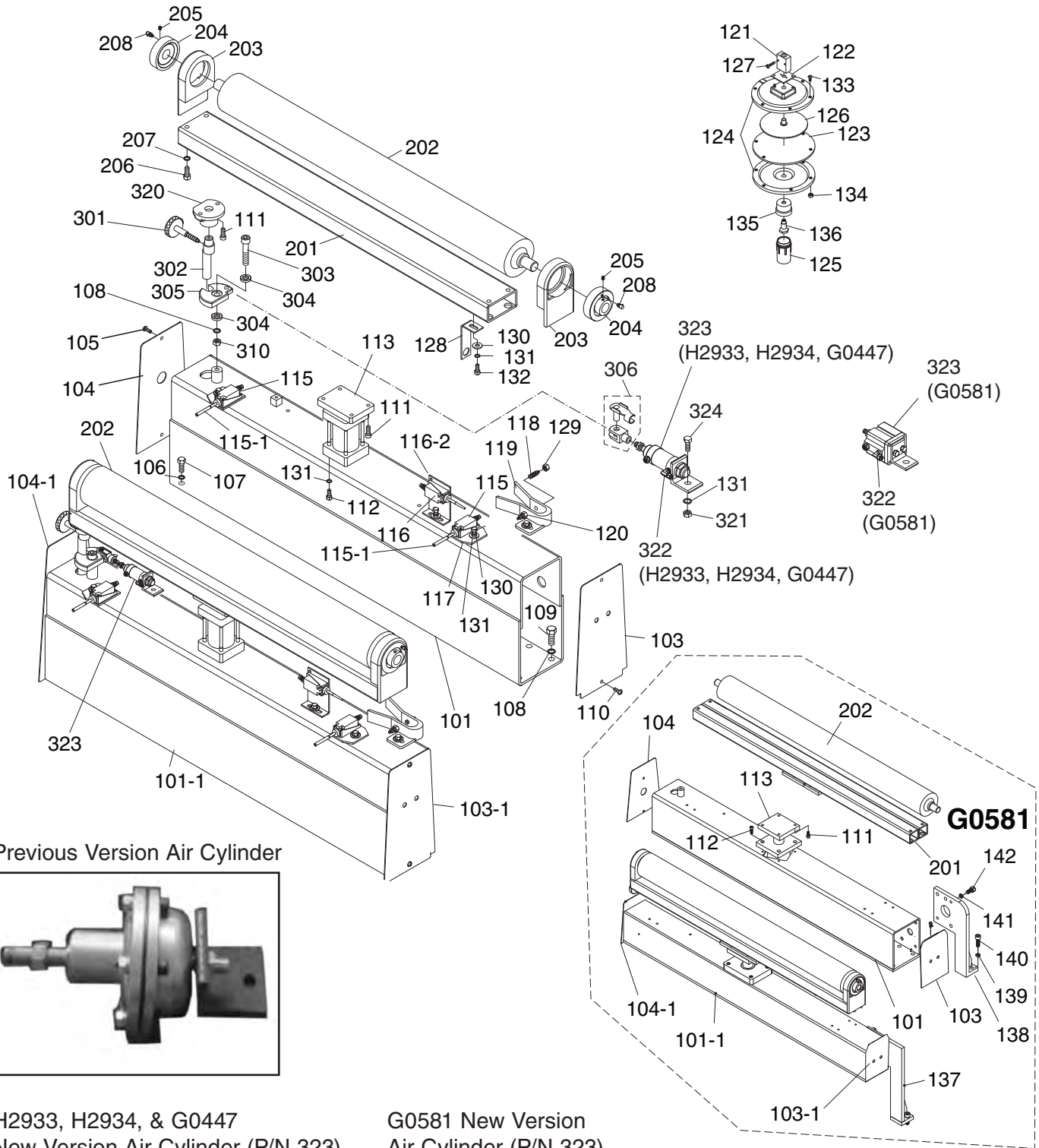

**Replaces Page 69**

# Upper Roller System Parts List

REF	PART #	DESCRIPTION
101	PH29336101	SQUARE FRAME REAR (H2933)
101	PH29346101	SQUARE FRAME REAR (H2934)
101	P04476101	SQUARE FRAME REAR (G0447)
101	P05816101	SQUARE FRAME REAR (G0581)
101-1	PH29336101-1	SQUARE FRAME FRONT (H2933)
101-1	PH29346101-1	SQUARE FRAME FRONT (H2934)
101-1	P04476101-1	SQUARE FRAME FRONT (G0447)
101-1	P05816101-1	SQUARE FRAME FRONT (G0581)
103	PH29336103	FRAME SEAL RIGHT (H2933)
103	PH29346103	FRAME SEAL RIGHT (H2934)
103	P04476103	FRAME SEAL RIGHT (G0447)
103	P05816103	FRAME SEAL RIGHT (G0581)
103-1	PH29336103-1	FRAME SEAL FRONT (H2933)
103-1	PH29346103-1	FRAME SEAL FRNT RT (H2934)
103-1	P04476103-1	FRAME SEAL FRNT RT (G0447)
103-1	P05816103-1	FRAME SEAL FRNT RT (G0581)
104	PH29336104	FRAME SEAL LEFT (H2933)
104	PH29346104	FRAME SEAL LEFT (H2934)
104	P04476104	FRAME SEAL LEFT (G0447)
104	P05816104	FRAME SEAL LEFT (G0581)
104-1	PH29336104-1	FRAME SEAL FRNT LFT (H2933)
104-1	PH29346104-1	FRAME SEAL FRNT LFT (H2934)
104-1	P04476104-1	FRAME SEAL FRNT LFT (G0447)
104-1	P05816104-1	FRAME SEAL FRNT LFT (G0581)
105	PFH03	FLAT HD SCR 1/4-20 X 1/2
106	PLW04	LOCK WASHER 3/8
107	PB18	HEX BOLT 3/8-16 X 1
108	PLW07	LOCK WASHER 1/2
109	PB53	HEX BOLT 1/2-12 X 1
110	PS04	PHLP HD SCR 1/4-20 X 1/2
111	PSB07	CAP SCREW 5/16-18 X 3/4
112	PB03	HEX BOLT 5/16-18 X 1
113	PH29336113	AIR CYLINDER
115	PH29336115	LIMIT SWITCH W/CERAMIC TIP
115-1	PH29336115-1	CERAMIC TIP
116	PH29336116	LIMIT SWITCH W/PLASTIC TIP
116-2	PH29336116-2	LIMIT SWITCH HOLDER, L-TYPE
117	PH29336117	LIMIT SWITCH HOLDER
118	PH29336118	AIR SENSOR NOZZLE FEMALE
119	PH29336119	AIR FORK
120	PH29336120	AIR SENSOR NOZZLE MALE
121	PH29336121	THROTTLE VALVE
122	PH29336122	THROTTLE VALVE BASE
123	PH29336123	PLATE
124	PH29336124	HOUSING ASSEMBLY
125	PH29336125	OIL CAP

REF	PART #	DESCRIPTION
126	PH29336126	ALUMINUM PLATE
127	PS02M	PHLP HD SCR M4-.7 X 12
128	PH29336128	SHUTDOWN BRACKET
129	PN11	HEX NUT 3/8-24
130	PW07	FLAT WASHER 5/16
131	PLW01	LOCK WASHER 5/16
132	PB09	HEX BOLT 5/16-18 X 1/2
133	PS08	PHLP HD SCR 10-24 X 3/4
134	PN07	HEX NUT 10-24
135	PH29336135	CONNECTOR OF OIL CAP
136	PH29336136	SHAFT OF OIL CAP
137	P0581137	BRACKET (G0581)
138	P0581138	BRACKET (G0581)
139	PSB08	CAP SCREW 5/16-18 X 1-1/2
140	PSB76	CAP SCREW 1/2-12 X 1-1/2
141	PLW07	LOCK WASHER 1/2
142	PB53	HEX BOLT 1/2-12 X 1
201	PH29336201	BRACKET (H2933, H2934, G0447)
201	P05816201	BRACKET (G0581)
202	P05816202	UPPER ROLLER (G0581)
202	PH29336202	UPPER ROLLER (H2933)
202	PH29346202	UPPER ROLLER (H2934/G0447)
203	PH29336203	UPPER ROLLER BRACKET
204	P99625204	BEARING UCC205
205	PSS02M	SET SCREW M6-1 X 6
206	PSB33	CAP SCREW 10-24 x 3/4
207	PLW04	LOCK WASHER 3/8
208	PH29336208	GREASE FITTING W/DUST CAP
301	P05816301	KNOB
302	PH29336302	ECCENTRIC ROD
303	PSB79	CAP SCREW 1/2-12 X 3-1/2
304	PW01	FLAT WASHER 1/2
305	PH29336305	ECCENTRIC PIECE
306	PH29336306	CLEVIS ASSEMBLY
310	PN06	HEX NUT 1/2-12
320	PH29336320	ECCENTRIC SHAFT FRAME
321	PN02	HEX NUT 5/16-18
322	PH29339124	CONNECTOR 1/4N X 1/8T X 90DEG (H2933, H2934, G0447)
322	P05819124	CONNECTOR 1/4N X 1/4T X 90DEG (G0581)
323	P0539499V2	OSCILLATING AIR CYLINDER 30 X 4 (H2933, H2934, G0447)
323	P05816323	OSCILLATING AIR CYLINDER 50 X 4 (G0581)
324	PB11	HEX BOLT 5/16-18 X 1-1/2



Replaces Page 74 & 75

# Belt Oscillation System

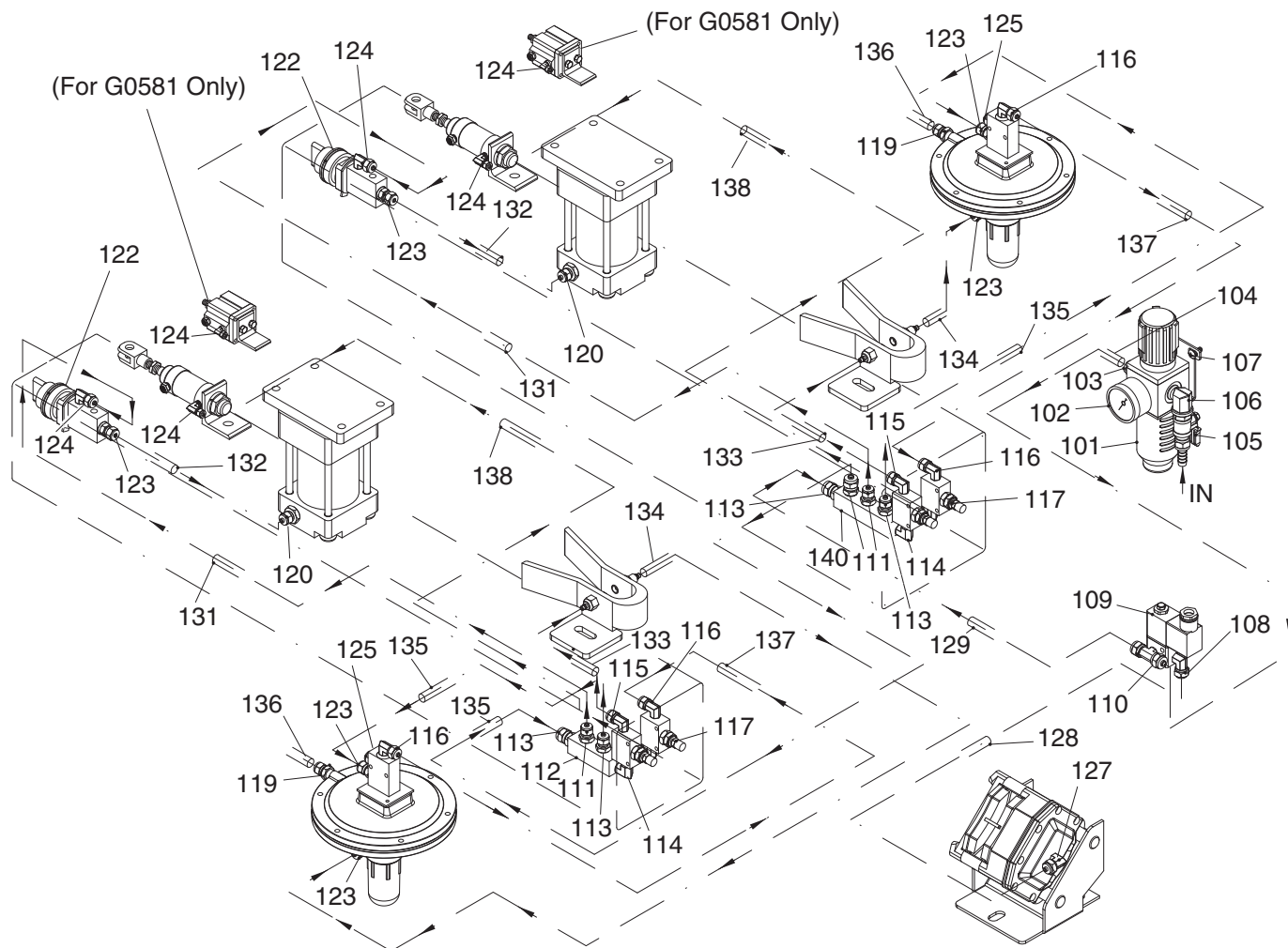

REF	PART #	DESCRIPTION
101	PH29339101	FILTER CUP
102	PH29339102	REGULATOR W/GAUGE
103	PH29339103	CONNECTOR, BRONZE
104	PH29339104	FLEXIBLE HOSE 6MM
105	PH29339105	AIR SWITCH
106	PH29339106	ELBOW
107	PH29339107	PHLP HD SCR 10-24 x 5/8
108	PH29339108	ELBOW 5/16N X 1/8T 90°
109	PH29339109	SOLENOID VALVE
110	PH29339110	T-FITTING 5/16N X 5/16N X 1/8T
111	PH29339111	CONNECTOR 5/16 X 1/4T BRONZE
112	PH29339112	MANIFOLD 1/4N 2-PORT
113	PH29339113	CONNECTOR 1/4N X 1/4T
114	PH29339114	ELBOW 1/4T X 1/8T 90°
115	PH29339115	CONNECTOR 1/4N X 1/8T 90°
116	PH29339116	CONNECTOR 1/4N X 1/8T 90°
117	PH29339117	THROTTLE VALVE
119	PH29339119	CONNECTOR 1/4N
120	PH29339120	CONNECTOR 1/4N X 3/8T

REF	PART #	DESCRIPTION
122	PH29339122	AIR SWITCH
123	PH29339123	CONNECTOR 1/4N X 1/8T
124	PH29339124	CONNECTOR 1/4N X 1/8T 90° (H2933,H2934, G0447)
124	P05819124	CONNECTOR 1/4N X 1/8T 90° (H2933,H2934, G0447)
125	PH29339125	BUFFER
127	PH29339127	CONNECTOR 5/16N X 1/8T 90°
128	PH29339128	8MM FLEXIBLE HOSE
129	PH29339129	8MM FLEXIBLE HOSE
131	PH29339131	6MM FLEXIBLE HOSE
132	PH29339132	6MM FLEXIBLE HOSE
133	PH29339133	6MM FLEXIBLE HOSE
134	PH29339134	6MM FLEXIBLE HOSE
135	PH29339135	6MM FLEXIBLE HOSE
136	PH29339136	6MM FLEXIBLE HOSE
137	PH29339137	6MM FLEXIBLE HOSE
138	PH29339138	6MM FLEXIBLE HOSE
140	PH29339140	MANIFOLD 1/4N 3-PORT



# *grizzly.com*<sup>®</sup>

**TOOL WEBSITE**

Buy Direct and Save with Grizzly<sup>®</sup> – Trusted, Proven and a Great Value!  
~Since 1983~

*Visit Our Website Today For  
Current Specials!*

**ORDER  
24 HOURS A DAY!  
1-800-523-4777**



# *Grizzly* **Industrial, Inc.**®

## **MODEL H2933/H2934/G0447/G0581 DOUBLE-HEAD WIDE-BELT SANDER INSTRUCTION MANUAL**



COPYRIGHT © SEPTEMBER 2005 BY GRIZZLY INDUSTRIAL, INC. REVISED JUNE 2006.  
**WARNING: NO PORTION OF THIS MANUAL MAY BE REPRODUCED IN ANY SHAPE  
OR FORM WITHOUT THE WRITTEN APPROVAL OF GRIZZLY INDUSTRIAL, INC.**  
#CR7108 PRINTED IN TAIWAN





# **WARNING!**

**Some dust created by power sanding, sawing, grinding, drilling, and other construction activities contains chemicals known to the State of California to cause cancer, birth defects or other reproductive harm. Some examples of these chemical are:**

- **Lead from lead-based paints.**
- **Crystalline silica from bricks, cement and other masonry products.**
- **Arsenic and chromium from chemically-treated lumber.**

**Your risk from these exposures varies, depending on how often you do this type of work. To reduce your exposure to these chemicals: Work in a well ventilated area, and work with approved safety equipment, such as those dust masks that are specially designed to filter out microscopic particles.**

# Table of Contents

- INTRODUCTION..... 3**
  - Foreword ..... 3
  - Contact Info ..... 3
  - Control Panel Features ..... 4
  - External Features ..... 4
  - Internal Features ..... 5
  - Machine Data Sheet (H2933)..... 6
  - Machine Data Sheet (H2934)..... 7
  - Machine Data Sheet (G0447) ..... 8
  - Machine Data Sheet (G0581) ..... 9
- SECTION 1: SAFETY ..... 10**
  - Safety Instructions for Machinery..... 10
  - Additional Safety for Wide Belt Sanders ..... 12
- SECTION 2: CIRCUIT REQUIREMENTS ..... 13**
  - 220V/440V Connection ..... 13
  - Extension Cords ..... 13
  - Grounding..... 13
  - Amperage Loads ..... 13
  - 440V Connection ..... 14
- SECTION 3: SET UP ..... 15**
  - Unpacking ..... 15
  - Inventory..... 15
  - Hardware Chart..... 16
  - Clean Up ..... 17
  - Site Considerations ..... 17
  - Beginning Assembly..... 18
  - Air Line Installation..... 18
  - Dust Collection ..... 18
  - Sanding Belt..... 19
  - Pressure Rollers..... 20
  - Start Up ..... 20
  - Recommended Adjustments ..... 21
- SECTION 4: OPERATIONS ..... 22**
  - Operation Safety ..... 22
  - Choosing Sandpaper..... 22
  - Table Movement..... 23
  - Adjusting Feed Rate..... 23
  - Amp Draw Meter ..... 24
  - Sanding Workpiece ..... 25
  - Platen Adjustment ..... 25
- SECTION 5: ACCESSORIES ..... 26**
- SECTION 6: MAINTENANCE..... 27**
  - General..... 27
  - Schedule ..... 27
  - Sanding Belts ..... 28
  - Air System ..... 28
  - Dust and Water Traps..... 28



<b>SECTION 7: SERVICE .....</b>	<b>29</b>
Table Calibration .....	29
Platen Service .....	29
Brake Service .....	30
Oscillation Timing .....	31
Oscillation Speed .....	33
Table Parallelism.....	33
Pressure Rollers.....	34
V-Belt Adjustment.....	35
Conveyor Belt Replacement .....	36
Feed Belt Tension .....	38
Feed Belt Tracking .....	38
Air System Diagram .....	39
Troubleshooting.....	40
Tool Box and Accessories Diagram.....	56
Tool Box and Accessories Parts List .....	57
Sanding Motor System Diagram .....	58
Sanding Motor System Parts List.....	59
Table Lift System Diagram.....	60
Table Lift System Parts List .....	61
Conveyor System Diagram .....	62
Conveyor System Parts List.....	63
Feed, Drum, and Pressure Roller Diagram.....	64
Feed, Drum, and Pressure Roller Parts List.....	65
Sanding Drum, and Platen Diagram .....	66
Sanding Drum, and Platen Parts List.....	67
Upper Roller System Diagram .....	68
Upper Roller System Parts List.....	69
Cabinet Assembly Diagram.....	70
Main Electrical Panel and Controls Diagram .....	72
Main Electrical Panel and Controls Parts List.....	73
Belt Oscillation System Diagram.....	74
Belt Oscillation System Parts List .....	75
Machine Label Diagram .....	76
Machine Label List .....	77
<b>WARRANTY &amp; RETURNS .....</b>	<b>78</b>



# INTRODUCTION

---

---

## Foreword

---

---

We are proud to offer the H2933/H2934/G0447/G0581 Wide Belt Sander. This machine is part of a growing Grizzly family of fine woodworking machinery. When used according to the guidelines set forth in this manual, you can expect years of trouble-free, enjoyable operation and proof of Grizzly's commitment to customer satisfaction.

We are pleased to provide this manual with the H2933/H2934/G0447/G0581 Wide Belt Sander. It was written to guide you through assembly, review safety considerations, and cover general operating procedures.

The specifications, drawings, and photographs illustrated in this manual represent the H2933/H2934/G0447/G0581 Wide Belt Sander as supplied when the manual was prepared. For your convenience, we always keep current Grizzly manuals available on our website at **[www.grizzly.com](http://www.grizzly.com)**. Any updates to your machine will be reflected in these manuals as soon as they are complete.

## Contact Info

---

---

If you have any comments regarding this manual, please write to us at the address below:

Grizzly Industrial, Inc.  
c/o Technical Documentation Manager  
P.O. Box 2069  
Bellingham, WA 98227-2069

We stand behind our machines. If you have any service questions or parts requests, please call or write us at the location listed below.

Grizzly Industrial, Inc.  
1203 Lycoming Mall Circle  
Muncy, PA 17756  
Phone: (570) 546-9663  
Fax: (800) 438-5901  
E-Mail: [techsupport@grizzly.com](mailto:techsupport@grizzly.com)  
Web Site: <http://www.grizzly.com>



# Control Panel Features

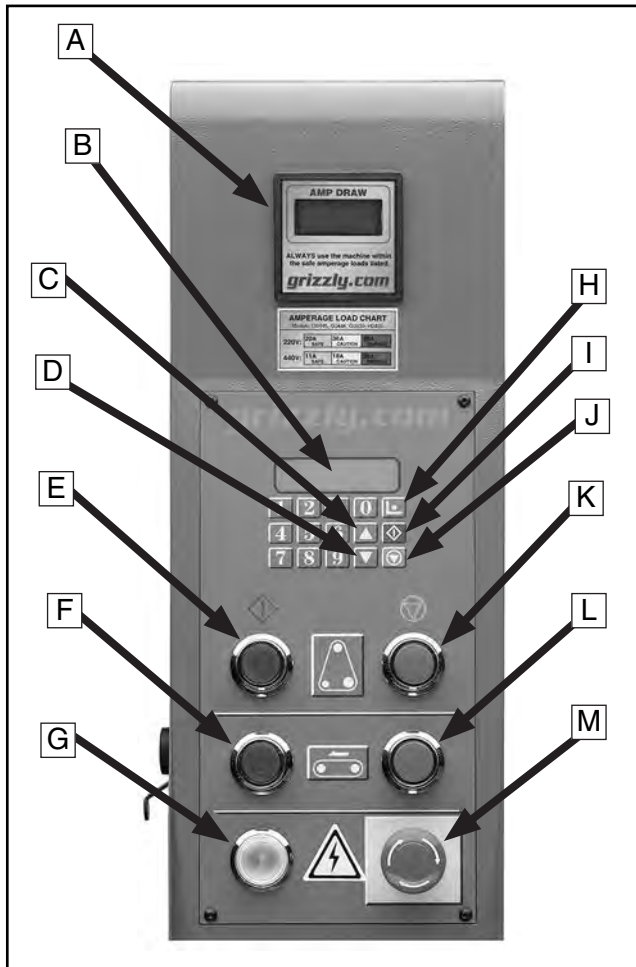

**Figure 1.** Control Panel.

- A. Digital Amp Draw Meter
- B. Table-Height Digital Readout
- C. Table Up Key
- D. Table Down Key
- E. Sanding Belt Start Button
- F. Conveyor Belt Start Button
- G. Power Light
- H. Table Set (Enter) Key
- I. Table Start Key
- J. Table Stop Key
- K. Sanding Belt Stop Button
- L. Feed Belt Stop Button
- M. Emergency Stop Button

# External Features

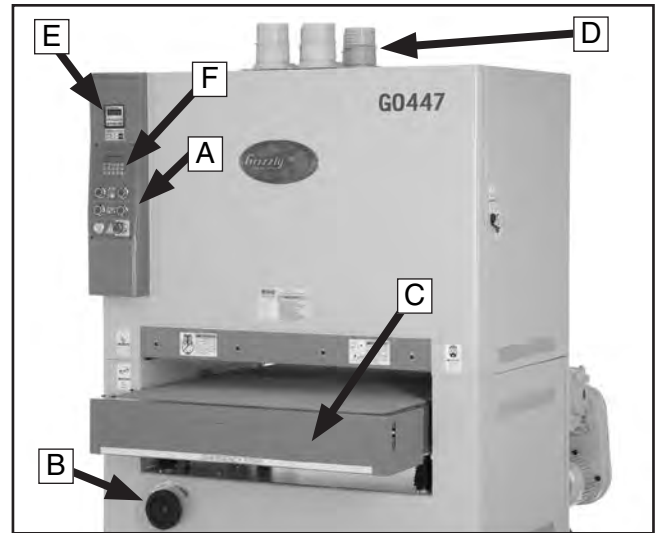

**Figure 2.** Front View.

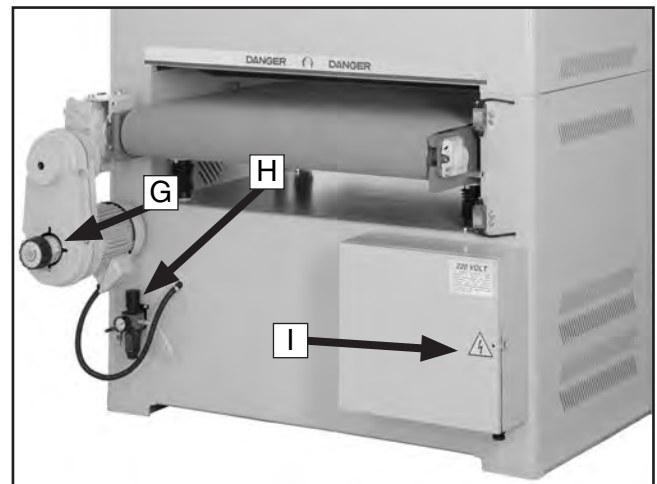

**Figure 3.** Rear View.

- A. Control Panel
- B. Table Height Handwheel
- C. Emergency Stop Push-Panel
- D. 4" Dust Collection Ports
- E. Amperage Load Chart
- F. Digital Table Height Key Pad
- G. Conveyor Speed Control
- H. Air Pressure Regulator
- I. Main Wiring Box





# Internal Features

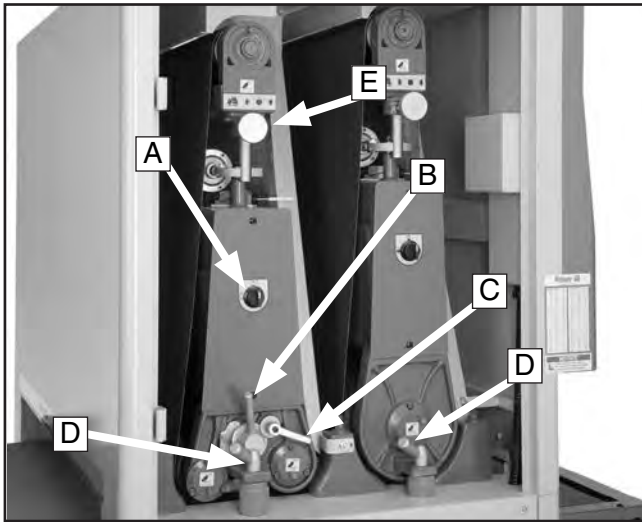

**Figure 4.** Inside the left access door.

- A.** Belt Tension Knob
- B.** Platen Adjustment Lever
- C.** Platen Adjustment Lock Lever
- D.** Lock Post Release Lever
- E.** Tracking Adjustment Knob

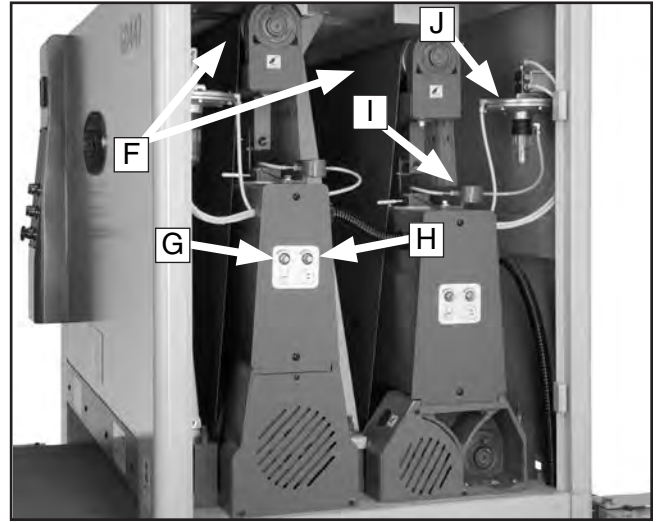

**Figure 5.** Inside the right access door.

- F.** Upper Rollers
- G.** Airflow Adjustment Knob
- H.** Speed Control Adjustment Knob
- I.** Air Fork and Air Jet
- J.** Diaphragm Valve Assembly





# MACHINE DATA SHEET

Customer Service #: (570) 546-9663 • To Order Call: (800) 523-4777 • Fax #: (800) 438-5901

## MODEL H2933 24" DOUBLE-HEAD WIDE-BELT SANDER

Design Type ..... Floor Model

### Overall Dimensions:

Overall Height ..... 71½"  
 Overall Width ..... 42"  
 Overall Depth ..... 59½"  
 Conveyor Height at Lowest Setting ..... 32"  
 Net Weight ..... 2314 lbs.  
 Shipping Weight ..... 2645 lbs.  
 Footprint ..... 40" x 31"

### Capacities:

Maximum Board Width ..... 24"  
 Maximum Board Thickness ..... 6"  
 Minimum Board Length ..... 14"  
 Minimum Board Thickness ..... ¼"  
 Drum Speed (Front) ..... 3543 FPM  
 Drum Speed (Rear) ..... 2565 FPM  
 Conveyor Speed ..... 14-60 FPM  
 Dust Ports ..... Four, 4"  
 Drum Diameter ..... (Front 7.87"), (Rear 4")

### Sanding Drum Motor:

Type ..... TEFC Induction  
 Horsepower ..... 15 HP  
 Voltage / Phase / Cycle ..... 220V / 440V Three-Phase / 60 HZ  
 Amps ..... 36 / 18A  
 RPM ..... 1725 RPM  
 Power Transfer to Drums ..... Triple and Twin V-Belt

### Conveyor Feed Motor:

Type ..... TEFC Induction  
 Horsepower ..... 1 HP  
 Voltage / Phase / Cycle ..... 220V / 440V Three-Phase / 60 HZ  
 Amps ..... 3.4 / 1.7A  
 RPM ..... 1725 RPM  
 Power Transfer ..... V-Belt

### Table Lift Motor:

Type ..... TEFC Induction  
 Horsepower ..... ¼ HP  
 Voltage / Phase / Cycle ..... 220V / 440V Three-Phase / 60 HZ  
 Amps ..... 1.2 / 0.6A  
 RPM ..... 1725 RPM  
 Power Transfer ..... V-Belt

### General Construction:

Cabinet ..... Steel  
 Operating Air Pressure ..... 75 PSI  
 Sanding Belt Oscillation ..... Adjustable  
 Emergency Sanding Belt Brake ..... Air Disc Brake  
 Control Panel ..... Push Button Motor Controls, and Amp Load Meter  
 Sanding Belt ..... 24" x 60"  
 Graphite Size ..... 24" x 3.5"  
 Sanding Type ..... Drum and Platen Style

*Specifications, while deemed accurate, are not guaranteed.*





# MACHINE DATA SHEET

Customer Service #: (570) 546-9663 • To Order Call: (800) 523-4777 • Fax #: (800) 438-5901

## MODEL H2934 37" DOUBLE-HEAD WIDE-BELT SANDER

Design Type .....	Floor Model
<b>Overall Dimensions:</b>	
Overall Height .....	71½"
Overall Width .....	54"
Overall Depth .....	59½"
Conveyor Height at Lowest Setting .....	32"
Net Weight .....	3086 lbs.
Shipping Weight .....	3527 lbs.
Footprint .....	52" x 31"
<b>Capacities:</b>	
Maximum Board Width .....	36½"
Maximum Board Thickness .....	6"
Minimum Board Length .....	14"
Minimum Board Thickness .....	¼"
Drum Speed (Front) .....	3543 FPM
Drum Speed (Rear) .....	2565 FPM
Conveyor Speed .....	14-60 FPM
Dust Ports .....	Six, 4"
Drum Diameter .....	(Front 7.87"), (Rear 4")
<b>Sanding Drum Motor:</b>	
Type .....	TEFC Induction
Horsepower .....	20 HP
Voltage / Phase / Cycle .....	220V / 440V Three-Phase / 60 HZ
Amps .....	50 / 25A
RPM .....	1725 RPM
Power Transfer to Drums .....	Twin and Triple V-Belt
<b>Conveyor Feed Motor:</b>	
Type .....	TEFC Induction
Horsepower .....	1 HP
Voltage / Phase / Cycle .....	220V / 440V Three-Phase / 60 HZ
Amps .....	3.4 / 1.7A
RPM .....	1725 RPM
Power Transfer .....	V-Belt
<b>Table Lift Motor:</b>	
Type .....	TEFC Induction
Horsepower .....	¼ HP
Voltage / Phase / Cycle .....	220V / 440V Three-Phase / 60 HZ
Amps .....	1.2 / 0.6A
RPM .....	1725 RPM
Power Transfer .....	V-Belt
<b>General Construction:</b>	
Cabinet .....	Steel
Operating Air Pressure .....	75 PSI
Sanding Belt Oscillation .....	Adjustable
Emergency Sanding Belt Brake .....	Air Disc Brake
Control Panel .....	Push Button Motor Controls, and Amp Load Meter
Sanding Belt .....	37" x 60"
Graphite Size .....	37" x 3.5"
Sanding Type .....	Drum and Platen Style

*Specifications, while deemed accurate, are not guaranteed.*





# MACHINE DATA SHEET

Customer Service #: (570) 546-9663 • To Order Call: (800) 523-4777 • Fax #: (800) 438-5901

## MODEL G0447 37" DOUBLE-HEAD TALL WIDE-BELT SANDER

Design Type ..... Floor Model

### Overall Dimensions:

Overall Height W/Dust Ports ..... 79"  
 Overall Height W/O Dust Ports ..... 73"  
 Overall Width ..... 53½"  
 Overall Depth ..... 59½"  
 Conveyor Height at Lowest Setting ..... 32"  
 Net Weight ..... 3197 lbs.  
 Shipping Weight ..... 3637 lbs.  
 Footprint ..... 52" x 31"

### Capacities:

Maximum Board Width ..... 36½"  
 Maximum Board Thickness ..... 6"  
 Minimum Board Length ..... 11"  
 Minimum Board Thickness ..... ¼"  
 Drum Speed (Front) ..... 3543 FPM  
 Drum Speed (Rear) ..... 2554 FPM  
 Conveyor Speed ..... 17-63 FPM  
 Dust Ports ..... Six, 4"  
 Drum Diameter ..... (Front 7.87"), (Rear 4")

### Sanding Drum Motor:

Type ..... TEFC Induction  
 Horsepower ..... 20 HP  
 Voltage / Phase / Cycle ..... 220V / 440V Three-Phase / 60 HZ  
 Amps ..... 50 / 25A  
 RPM ..... 1725 RPM  
 Power Transfer to Drums ..... Triple V-Belt

### Conveyor Feed Motor:

Type ..... TEFC Induction  
 Horsepower ..... 1 HP  
 Voltage / Phase / Cycle ..... 220V / 440V Three-Phase / 60 HZ  
 Amps ..... 3.4 / 1.7A  
 RPM ..... 1725 RPM  
 Power Transfer ..... Twin and Triple V-Belt

### Table Lift Motor:

Type ..... TEFC Induction  
 Horsepower ..... ¼ HP  
 Voltage / Phase / Cycle ..... 220V / 440V Three-Phase / 60 HZ  
 Amps ..... 1.2 / 0.6A  
 RPM ..... 1725 RPM  
 Power Transfer ..... V-Belt

### General Construction:

Cabinet ..... Steel  
 Operating Air Pressure ..... 75 PSI  
 Sanding Belt Oscillation ..... Adjustable  
 Emergency Sanding Belt Brake ..... Air Disc Brake  
 Control Panel ..... Push Button Motor Controls, and Amp Load Meter  
 Sanding Belt ..... 37" x 75"  
 Graphite Size ..... 37.8" x 3.5"  
 Sanding Type ..... Platen Style

*Specifications, while deemed accurate, are not guaranteed.*





# MACHINE DATA SHEET

Customer Service #: (570) 546-9663 • To Order Call: (800) 523-4777 • Fax #: (800) 438-5901

## MODEL G0581 43" DOUBLE-HEAD WIDE-BELT SANDER

Design Type ..... Floor Model

### Overall Dimensions:

Overall Height W/Dust Ports ..... 72½"  
 Overall Height W/O Dust Ports ..... 66½"  
 Overall Width ..... 63½"  
 Overall Depth ..... 60½"  
 Conveyor Height at Lowest Setting ..... 32"  
 Net Weight ..... 3086 lbs.  
 Shipping Weight ..... 3968 lbs.  
 Footprint ..... 61" x 31½"

### Capacities:

Maximum Board Width ..... 43"  
 Maximum Board Thickness ..... 6"  
 Minimum Board Length ..... 14"  
 Minimum Board Thickness ..... ¼"  
 Front Drum Speed ..... 3543 FPM  
 Rear Drum Speed ..... 2565 FPM  
 Conveyor Speed ..... 14-63 FPM  
 Dust Ports ..... Ten, 4"  
 Drum Diameter (Front) ..... 7.87"  
 Drum Diameter (Rear) ..... 4"

### Sanding Drum Motor:

Type ..... TEFC Induction  
 Horsepower ..... 25 HP  
 Voltage / Phase / Cycle ..... 220V / 440V Three-Phase / 60 HZ  
 Amps ..... 64 / 32A  
 RPM ..... 1725 RPM  
 Power Transfer to Drums ..... Twin and Triple V-Belt

### Conveyor Feed Motor:

Type ..... TEFC Induction  
 Horsepower ..... 2 HP  
 Voltage / Phase / Cycle ..... 220V / 440V Three-Phase / 60 HZ  
 Amps ..... 6 / 3A  
 RPM ..... 1725 RPM  
 Power Transfer ..... V-Belt

### Table Lift Motor:

Type ..... TEFC Induction  
 Horsepower ..... ¼ HP  
 Voltage / Phase / Cycle ..... 220V / 440V Three-Phase / 60 HZ  
 Amps ..... 1.2 / 0.6A  
 RPM ..... 1725 RPM  
 Power Transfer ..... V-Belt

### General Construction:

Cabinet ..... Steel  
 Operating Air Pressure ..... 75 PSI  
 Sanding Belt Oscillation ..... Adjustable  
 Emergency Sanding Belt Brake ..... Air Disc Brake  
 Control Panel ..... Push Button Motor Controls, and Amp Load Meter  
 Sanding Belt ..... 43.3" x 60"  
 Graphite Size ..... 43" x 3.5"  
 Sanding Type ..... Drum and Platen Style

*Specifications, while deemed accurate, are not guaranteed.*



# SECTION 1: SAFETY

## WARNING

### For Your Own Safety, Read Instruction Manual Before Operating this Machine

The purpose of safety symbols is to attract your attention to possible hazardous conditions. This manual uses a series of symbols and signal words which are intended to convey the level of importance of the safety messages. The progression of symbols is described below. Remember that safety messages by themselves do not eliminate danger and are not a substitute for proper accident prevention measures.

 **DANGER** Indicates an imminently hazardous situation which, if not avoided, WILL result in death or serious injury.

 **WARNING** Indicates a potentially hazardous situation which, if not avoided, COULD result in death or serious injury.

 **CAUTION** Indicates a potentially hazardous situation which, if not avoided, MAY result in minor or moderate injury. It may also be used to alert against unsafe practices.

**NOTICE** This symbol is used to alert the user to useful information about proper operation of the machine.

## WARNING

### Safety Instructions for Machinery

- 1. READ THROUGH THE ENTIRE MANUAL BEFORE STARTING MACHINERY.** Machinery presents serious injury hazards to untrained users.
- 2. ALWAYS USE ANSI APPROVED SAFETY GLASSES WHEN OPERATING MACHINERY.** Everyday eyeglasses only have impact resistant lenses, they are NOT safety glasses.
- 3. ALWAYS WEAR AN ANSI APPROVED RESPIRATOR WHEN OPERATING MACHINERY THAT PRODUCES DUST.** Wood dust is a carcinogen and can cause cancer and severe respiratory illnesses.
- 4. ALWAYS USE HEARING PROTECTION WHEN OPERATING MACHINERY.** Machinery noise can cause permanent hearing damage.
- 5. WEAR PROPER APPAREL. DO NOT** wear loose clothing, gloves, neckties, rings, or jewelry which may get caught in moving parts. Wear protective hair covering to contain long hair and wear non-slip footwear.
- 6. NEVER OPERATE MACHINERY WHEN TIRED, OR UNDER THE INFLUENCE OF DRUGS OR ALCOHOL.** Be mentally alert at all times when running machinery.



# WARNING

## Safety Instructions for Machinery

7. **ONLY ALLOW TRAINED AND PROPERLY SUPERVISED PERSONNEL TO OPERATE MACHINERY.** Make sure operation instructions are safe and clearly understood.
8. **KEEP CHILDREN AND VISITORS AWAY.** Keep all children and visitors a safe distance from the work area.
9. **MAKE WORKSHOP CHILD PROOF.** Use padlocks, master switches, and remove start switch keys.
10. **NEVER LEAVE WHEN MACHINE IS RUNNING.** Turn power **OFF** and allow all moving parts to come to a complete stop before leaving machine unattended.
11. **DO NOT USE IN DANGEROUS ENVIRONMENTS.** DO NOT use machinery in damp, wet locations, or where any flammable or noxious fumes may exist.
12. **KEEP WORK AREA CLEAN AND WELL LIT.** Clutter and dark shadows may cause accidents.
13. **USE A GROUNDED EXTENSION CORD RATED FOR THE MACHINE AMPERAGE.** Undersized cords overheat and lose power. Replace extension cords if they become damaged. DO NOT use extension cords for 220V machinery.
14. **ALWAYS DISCONNECT FROM POWER SOURCE BEFORE SERVICING MACHINERY.** Make sure switch is in OFF position before reconnecting.
15. **MAINTAIN MACHINERY WITH CARE.** Keep blades sharp and clean for best and safest performance. Follow instructions for lubricating and changing accessories.
16. **MAKE SURE GUARDS ARE IN PLACE AND WORK CORRECTLY BEFORE USING MACHINERY.**
17. **REMOVE ADJUSTING KEYS AND WRENCHES.** Make a habit of checking for keys and adjusting wrenches before turning machinery **ON**.
18. **CHECK FOR DAMAGED PARTS BEFORE USING MACHINERY.** Check for binding and alignment of parts, broken parts, part mounting, loose bolts, and any other conditions that may affect machine operation. Repair or replace damaged parts.
19. **USE RECOMMENDED ACCESSORIES.** Refer to the instruction manual for recommended accessories. The use of improper accessories may cause risk of injury.
20. **DO NOT FORCE MACHINERY.** Work at the speed for which the machine or accessory was designed.
21. **SECURE WORKPIECE.** Use clamps or a vise to hold the workpiece when practical. A secured workpiece protects your hands and frees both hands to operate the machine.
22. **DO NOT OVERREACH.** Keep proper footing and balance at all times.
23. **MANY MACHINES WILL EJECT THE WORKPIECE TOWARD THE OPERATOR.** Know and avoid conditions that cause the workpiece to "kickback."
24. **ALWAYS LOCK MOBILE BASES (IF USED) BEFORE OPERATING MACHINERY.**
25. **BE AWARE THAT CERTAIN WOODS MAY CAUSE AN ALLERGIC REACTION** in people and animals, especially when exposed to fine dust. Make sure you know what type of wood dust you will be exposed to and always wear an approved respirator.





## **WARNING**

# Additional Safety for Wide Belt Sanders

- 1. INFEED/OUTFEED AREA.** When feeding the workpiece into the machine, keep clear of kickback path.
- 2. WORKPIECE FEEDING.** Never force the workpiece into the sander, and feed only one workpiece at a time.
- 3. CLOTHING.** Roll up or button sleeves, tie all loose clothing or hair so it will keep clear of entanglement hazards.
- 4. NARROW WORKPIECES.** Never sand workpieces narrower than  $\frac{1}{8}$ ".
- 5. THIN WORKPIECES.** Never sand workpieces thinner than  $\frac{1}{8}$ ".
- 6. SHORT WORKPIECES.** Never sand workpieces shorter than 14".
- 7. HANDS.** Never place hands near, or in contact with, sanding drums or conveyor belt during operation.
- 8. MAINTENANCE.** Perform machine inspections and maintenance service at the appropriate time intervals.
- 9. POWER AND AIR DISCONNECT.** Unless specifically stated in the manual, always disconnect the power source and air from the machine when performing maintenance, adjustments, or assembly. Always read and follow specific safety instructions for each section.
- 10. UNATTENDED MACHINE.** Never leave the machine running unattended.
- 11. SANDPAPER.** Replace sanding belt when it becomes worn or damaged.
- 12. FOREIGN MATERIAL.** Always inspect workpiece for nails, staples, knots, and other imperfections that could be dislodged and thrown from the machine during sanding operations.
- 13. DUST COLLECTION.** Never operate the sander without an adequate dust collection system in place and running.
- 14. ALLERGIES.** Certain woods may cause an allergic reaction in people and animals, especially when exposed to fine dust. Make sure you know what type of wood dust you will be exposed to and always wear an approved respirator.
- 15. ACCESS DOORS.** Never perform sanding operations when the side access doors are open.
- 16. UNDERSTAND INSTRUCTIONS.** Never allow unsupervised or untrained personnel to operate the machine. Make sure any instructions you give in regards to machine operation are approved, correct, safe, and clearly understood.

## **WARNING**

Unfamiliarity with this manual could result in serious personal injury. Spend a sufficient amount of time becoming familiar with the contents of this manual, including all the safety warnings.

## **WARNING**

No list of safety guidelines can be complete. Operating this machinery may require additional safety precautions specific to your shop environment. Failure to use reasonable caution while operating this machine could result in serious personal injury.



# SECTION 2: CIRCUIT REQUIREMENTS

## 220V/440V Connection

Hard wire this machine to your power panel that can safely supply power to your machine, and has the proper overload protection, and has a locking shut-off lever (**Figure 6**). If you are unsure about electrical wiring, consult a qualified electrician before attempting any wiring.

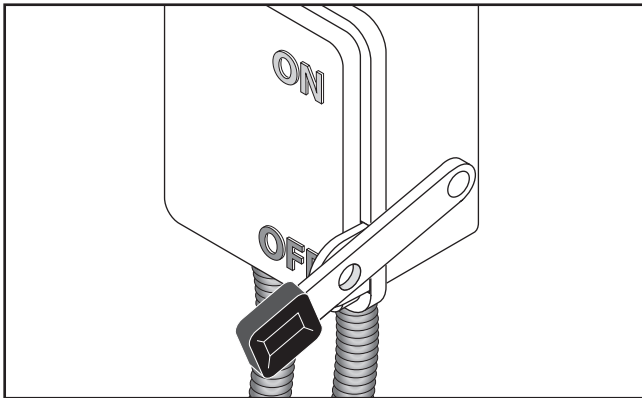

**Figure 6.** Locking Shut-Off Lever.

## Extension Cords

Do not use an extension cord with 220V/440V machinery. An extension cord increases the risk of electrocution and fire. Instead, position your equipment near the power supply to eliminate the extension cord requirement.

## Grounding

	<p><b>⚠ WARNING</b></p> <p>Electrocution or fire may result if machinery is incorrectly grounded or the power supply violates local and state codes. Contact a qualified electrician for safe wiring practices!</p>
--	---

## Amperage Loads

The following list outlines the electrical phase and voltage required to operate the various sander models, as well as the amperage draw of their motors. **Note:** *If you do not have three-phase power available, you will have to install a phase converter such as the Grizzly Phase Converter.*

### Amperage Draw Specifications:

#### H2933—220V, Three-Phase ~40 Amp

15 HP Sanding Motor.....	36 Amps
1 HP Feed Motor.....	3.4 Amps
¼ HP Table Motor.....	1.2 Amps

#### H2933—440V, Three-Phase ~20 Amp

15 HP Sanding Motor.....	18 Amps
1 HP Feed Motor.....	1.7 Amps
¼ HP Table Motor.....	0.6 Amp

#### H2934/G0447—220V, Three-Phase ~50 Amp

20 HP Sanding Motor.....	50 Amps
1 HP Feed Motor.....	3.4 Amps
¼ HP Table Motor.....	1.2 Amps

#### H2934/G0447—440V, Three-Phase ~25 Amp

20 HP Sanding Motor.....	25 Amps
1 HP Feed Motor.....	1.7 Amps
¼ HP Table Motor.....	0.6 Amp

#### G0581—220V, Three-Phase ~60 Amp

25 HP Sanding Motor.....	64 Amps
2 HP Feed Motor.....	6 Amps
¼ HP Table Motor.....	1.2 Amps

#### G0581—440V, Three-Phase ~25 Amp

25 HP Sanding Motor.....	32 Amps
2 HP Feed Motor.....	3 Amps
¼ HP Table Motor.....	0.6 Amp



# 440V Connection

To connect this machine to 440V three-phase, you must purchase two overload relays. Each machine model may require unique relays, so refer to **440 Conversion Relays** on **Page 73** for the relay part numbers.

If you do not have three-phase power available for your wide belt sander, you must install a phase converter such as a Grizzly Phase Converter.

**Note:** When using a phase converter, the power from the manufactured power leg (sometimes called the wild wire) can fluctuate. Connect the manufactured power leg to the S terminal to prevent damage to the transformer. The wire from the S terminal can handle some fluctuation because it goes directly to the motor. The power going to the R and T terminals goes to the transformer and must be consistent to prevent damage.

## To wire the sander to 440V:

1. DISCONNECT THE SANDER FROM THE POWER SOURCE!
2. Open the electrical box located on the back of the machine.
3. On the transformer, remove the wire connected to the 220V terminal for your model of sander, and connect it to the 440V terminal as shown in **Figures 7**.

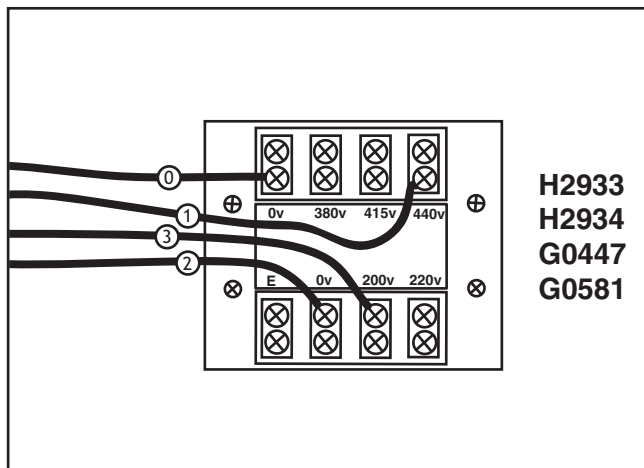

**Figure 7.** 440V connection.

4. Refer to **Figure 8** and find the power panel on your machine.
5. Swap out the applicable thermal relay at the locations shown in **Figure 8**, and set it to the overload values listed.

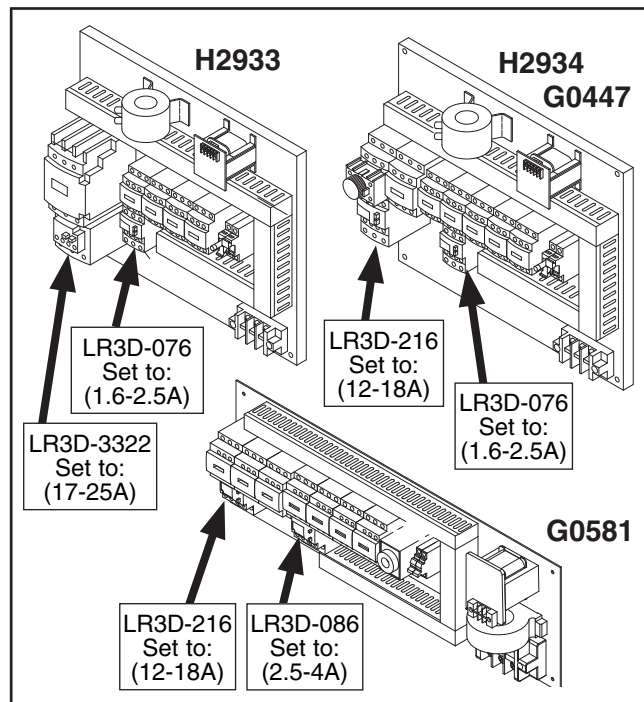

**Figure 8.** Overload relays.

6. Wire the sanding belt, conveyor belt, and table elevation motors as shown on the diagrams on the inside of each motor wire cover, or refer to **Motor Wiring** on **Page 55**.



# SECTION 3: SET UP

## Unpacking

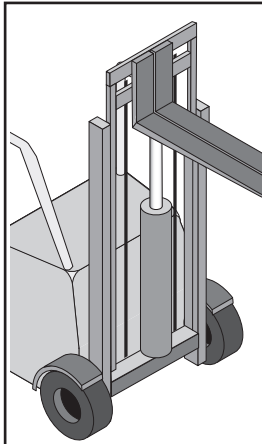

### **WARNING**

This sander is a heavy machine weighing in at over 2000 lbs. Personal injury can occur if the machine is moved without appropriate machinery. Use a crane or forklift when moving or lifting the machine.

Your wide belt sander was carefully packed when it left our warehouse. If you discover the machine is damaged after you have signed for delivery, please immediately call Customer Service at (570) 546-9663 for advice.

Save the containers and all packing materials for possible inspection by the carrier or its agent. Otherwise, filing a freight claim can be difficult.

When you are completely satisfied with the condition of your shipment, you should inventory the contents.

### **NOTICE**

A parts diagram and parts list are located near the end of the manual. Use the diagram and list to identify missing parts or to supplement the assembly instructions provided in this manual.

## Inventory

Crate contents, (Figure 9).	Qty
A. Sanding Unit (Not Pictured) .....	1
B. Dust Port 4" (H2933, H2934, G0447) .....	6
Dust Port 4" (G0581).....	10
C. Sanding Belt 100 Grit.....	1
D. Sanding Belt 180 Grit.....	1
E. Platen Graphite Flap .....	2
F. Platen Felt .....	1
G. Tool Box.....	1
— Phillips Head Screwdriver #2.....	1
— Standard Screwdriver #2.....	1
— Open-End Wrench 8/10mm.....	1
— Open-End Wrench 12/14mm.....	1
— Open-End Wrench 17/19mm .....	1
— Metric Hex Wrench Set 10 Pcs.....	1
— Door Key.....	2
— Ceramic Limit Switch Rub Rod.....	2
— Flexible Grease Gun Extension.....	1
— Platen Removal Tool .....	1

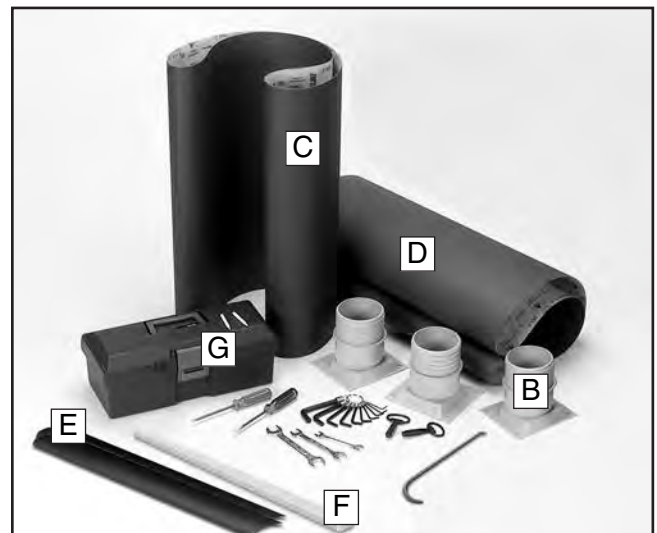







Figure 9. Parts layout.









# Hardware Chart

USE THIS CHART TO MATCH UP HARDWARE DURING THE ASSEMBLY PROCESS.

MEASURE BOLT DIAMETER BY PLACING INSIDE CIRCLE

-  #10
-  1/4"
-  5/16"
-  3/8"
-  7/16"
-  1/2"

-  4mm
-  5mm
-  6mm
-  8mm
-  10mm
-  12mm
-  16mm

**WASHER DIAMETER** 5/8"

**WASHER DIAMETER** 9/16"

**WASHER DIAMETER** 1/2"

**WASHER DIAMETER** 7/16"

**WASHER DIAMETER** 3/8"

**WASHER DIAMETER** 5/16"

**WASHER DIAMETER** 4mm

**WASHER DIAMETER** 10mm

**WASHER DIAMETER** 6mm

**WASHER DIAMETER** 8mm

**WASHER DIAMETER** #10

**LINES ARE 1MM APART**

5mm  
10mm  
15mm  
20mm  
25mm  
30mm  
35mm  
40mm  
45mm  
50mm  
55mm  
60mm  
65mm  
70mm  
75mm

**LINES ARE 1/16" INCH APART**

1/4"  
3/8"  
1/2"  
5/8"

5/16"  
7/16"  
9/16"  
3/4"  
7/8"  
1"  
1 1/4"  
1 1/2"  
1 3/4"  
2  
2 1/4"  
2 1/2"  
2 3/4"  
3

**WASHERS ARE MEASURED BY THE INSIDE DIAMETER**





# Clean Up

Any unpainted surfaces are coated with a waxy oil to protect them from corrosion during shipment. Remove this protective coating with a solvent cleaner or citrus-based degreaser such as Grizzly's G7895 Degreaser. To clean thoroughly, some parts may need to be removed. **For optimum performance from your machine, make sure you clean all moving parts or sliding contact surfaces that are coated.** Avoid chlorine-based solvents as they may damage painted surfaces should they come in contact.

	<p><b>!WARNING</b> Gasoline and petroleum products have low flash points and could explode if used to clean machinery. <b>DO NOT</b> use gasoline or petroleum products to clean the machinery.</p>
---	---

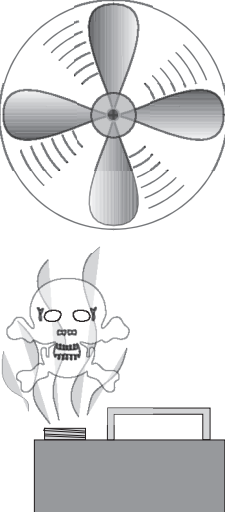
	<p><b>!WARNING</b> Lack of ventilation while using solvents could cause serious personal health risks, fire, or environmental hazards. Always work in a well ventilated area to prevent the accumulation of dangerous fumes. Supply the work area with a constant source of fresh air.</p>
---	--

# Site Considerations

## Floor Load

Refer to the **Machine Data Sheet** for the weight and footprint specifications of your machine. Some shop floors may require additional reinforcement to support both the machine and operator.

## Working Clearance

Working clearances can be thought of as the distances between machines and obstacles that allow safe operation of every machine without limitation. Refer to the **Machine Data Sheet** for dimensions of your machine. Consider existing and anticipated machine needs, size of material to be processed through each machine, and space for auxiliary stands and/or work tables. Also, consider the relative position of each machine to one another for efficient material handling. Be sure to allow yourself sufficient room to safely run your machines in any foreseeable operation and keep dust collection hoses off the floor and out of the way.

## Lighting

Lighting should be bright enough to eliminate shadows and prevent eye strain. Electrical circuits should be dedicated or large enough to handle combined motor amp loads. Be sure to observe local electrical codes for proper installation of new lighting or circuits.

	<p><b>!WARNING</b> Unsupervised children and visitors entering a shop could suffer serious personal injury. Ensure child and visitor safety by keeping all entrances to the shop locked at all times. <b>DO NOT</b> allow unsupervised children or visitors in the shop at any time.</p>
--	--



# Beginning Assembly

Complete the assembly in the order provided in this manual. Then read the rest of the manual before attempting any type of sanding operation. **Your safety is important! Please follow the warnings below during this entire section:**

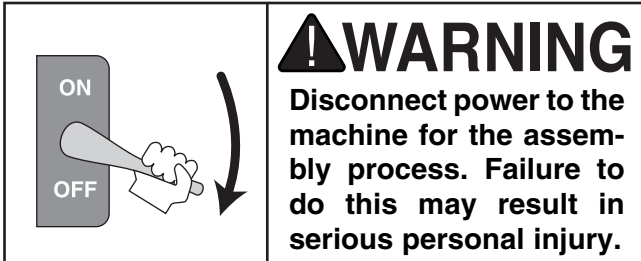

## Air Line Installation

To install the air line:

1. Connect the hose from your air compressor to the air inlet (**Figure 10**) on the regulator.

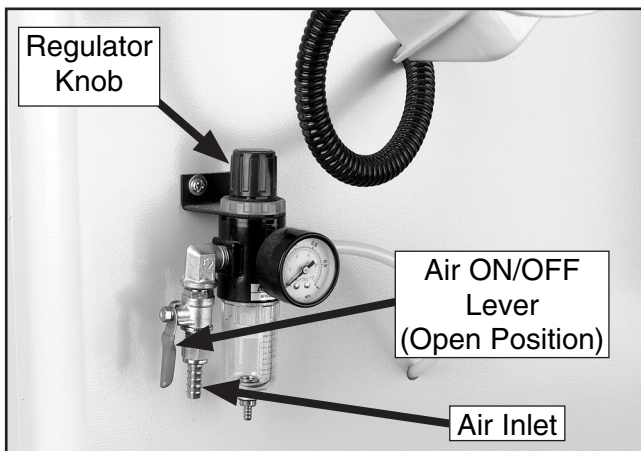

**Figure 10.** Air inlet located on regulator.

2. Make sure the red handle on the regulator is in the open position (parallel with the air inlet).
3. Lift the regulator knob (**Figures 10 and 11**) and turn it until the air pressure gauge reads 75 PSI. **Note:** Turn the knob clockwise to increase the air pressure and counterclockwise to lower the air pressure.
4. Push the regulator knob down until it snaps.

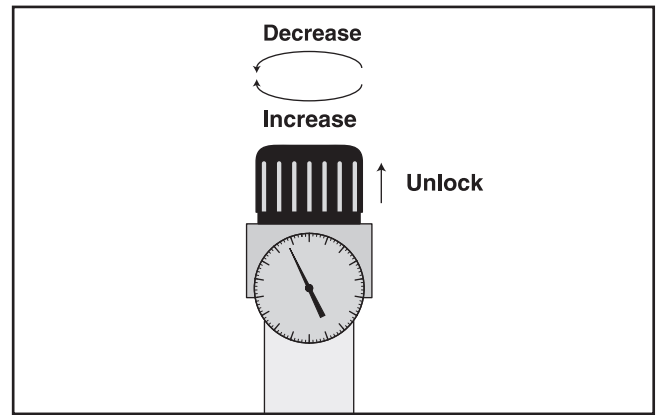

**Figure 11.** Regulator knob.

## Dust Collection

An efficient and clean dust collection system is essential to the proper function of the sander. Ensuring a healthy work environment is also dependent upon cleaning and maintaining your dust collection system. For the H2933/H2934/G0447 we recommend a minimum of: 2400 CFM, and for the G0581: 4000 CFM is recommended.

To hook up a dust collection system:

1. Install the dust ports (**Figure 12**) to the mounting locations on the top of the sanding unit with the supplied M6-1 x 10 Phillips head screws.



**Figure 12.** Example of ports installed.

2. Using 4" hose clamps, secure the hoses from your dust collection system to the dust ports.





# Sanding Belt

## To install the sanding belt:

1. DISCONNECT THE SANDER FROM THE POWER SOURCE!
2. De-activate the belt tension piston by turning the belt tension knob (**Figure 13**).
3. Remove the lock post release lever (**Figure 13**) by turning it counterclockwise  $\frac{1}{2}$  turn and pulling it up and out of the mounting hole.
4. Remove the spacer block (**Figure 13**).

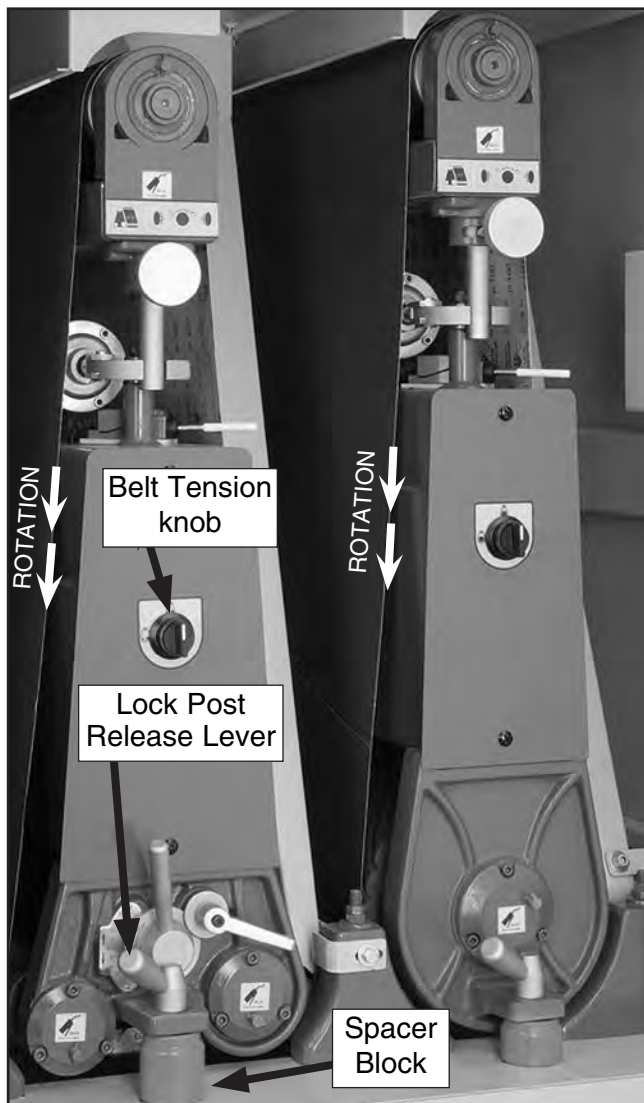

**Figure 13.** Components used when changing a sanding belt.

5. Making sure the rotation arrows on the sanding belt point the same direction as those shown in **Figure 13**, install the sanding belt by starting first on the upper roller, and then the lower roller.

**Note:** The sanding belt must be centered between the limit switches and the edge of the sanding belt must be between tongs of the oscillation controller as shown in **Figure 14**. Damage to the sanding belt could occur if the sander is turned **ON** before the sanding belt is correctly positioned.

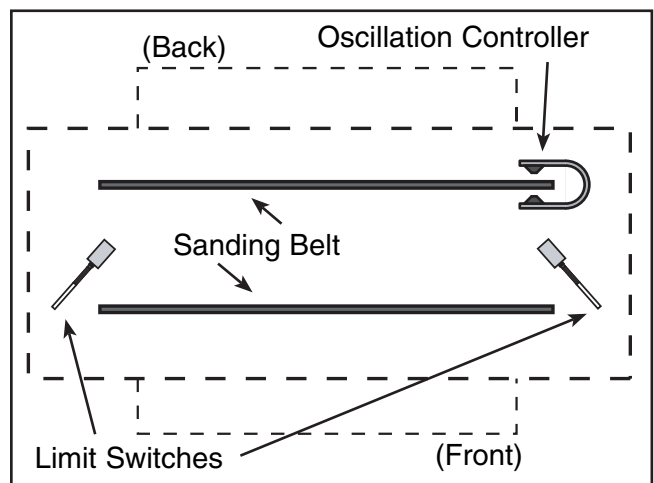

**Figure 14.** Sander Outline (Top View). Proper position of belt between the limit switches.

## **NOTICE**

The directional arrow on the back of the sanding belt must be pointing in a counterclockwise direction during installation. Failure to install the sanding belt correctly could result in damage to the sanding belt or the sander itself.

6. Replace the spacer block and tighten down the lock handle bolt.
7. With your hands clear of all moving parts, tension the belt by turning the belt tension knob.



# Pressure Rollers

The pressure rollers have been set at the factory, but for safety, you should verify that they are set below the level of the sanding roller.

## **WARNING**

It is absolutely essential to keep the pressure rollers set below the level of the sanding roller. If the pressure rollers are even, or higher than the sanding roller, the wood **WILL** be propelled from the sander at a high rate of speed. This situation could cause serious kick-back injury.

### To check the pressure roller height:

1. DISCONNECT THE SANDER FROM THE POWER SOURCE!
2. Place a piece of scrap wood of uniform thickness across the table so it spans both the front and the rear pressure rollers at the same time.
3. With the air pressure connected and the sanding belt installed and tensioned, manually raise the table and verify that the board touches both pressure rollers before it touches the sanding belt.

**Note:** *If the board does not touch both pressure rollers before it touches the sanding belt, then the pressure rollers must be adjusted before operation. See "**Pressure Rollers**" on **Page 34** for step-by-step instructions.*

# Start Up

## **WARNING**

Serious personal injury could result if the machine is connected to the power source during assembly or adjustment. Wait until the machine is turned off, unplugged, and all working parts have come to a complete stop before you attempt to assemble or adjust the machine!

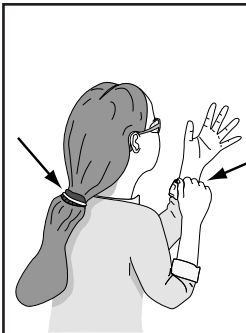

## **WARNING**

Loose hair and clothing could get caught in machinery causing serious personal injury. Keep loose clothing rolled up and long hair tied up and away from machinery.



## **WARNING**

Projectiles thrown from the machine could cause serious eye injury. Wear safety glasses during start up.

### Before starting the machine:

1. Read this manual and make sure you take all safety precautions before operating this machine.
2. Make sure the machine is connected to an air compressor and the pressure gauge reads 75 PSI.
3. Make sure all tools or foreign objects have been removed from the conveyor surface, the top of the machine, and the inside of the machine.
4. Make sure all the wiring is correct.



## To start the machine:

1. **Wear safety glasses and respirator at all times when running the machine!**
2. Connect the machine to the power source.
3. Press the TABLE UP and TABLE DOWN keys. The table should go up and down smoothly.

**Note:** *Make sure the table moves in the same direction as the button description. If not, then the power needs to be disconnected and any two power wires need to be switched at the circuit breaker in the electrical box. If using a phase converter, switch the R and T wires.*

4. Press the FEED BELT START and FEED BELT STOP buttons. The feed belt should start, run, and stop smoothly.
5. Press the SANDING BELT START and SANDING BELT STOP buttons. The sanding belt should start, run, and stop smoothly.

The machine should run smoothly, with little or no vibration or rubbing noises. Strange or unnatural noises should be investigated and corrected before operating the machine further.

If the machine seems to be running correctly, let it run for a short time to ensure that the moving parts are working properly with no excessive vibration. DO NOT operate the machine if problems cannot be corrected.

If you cannot locate the source of unusual noises, refer to **Troubleshooting**, and feel free to contact our Technical Support Department at (570) 546-9663.

# Recommended Adjustments

---

---

For your convenience, the adjustments listed below have been performed at the factory and require no further adjustment. However, we recommend that you verify that the adjustments are correct and to your satisfaction.

## Recommended adjustment checklist:

- Table Calibration, Page 29.
- Feed Belt Tension, Page 38.
- Feed Belt Tracking, Page 38.
- Air Regulator to 75 PSI, Page 28.
- Oscillation Timing, Page 31.
- Oscillation Speed, Page 33.
- Pressure Rollers, Page 20.
- Table Parallelism, Page 33.
- V-Belt Adjustment, Page 35.



# SECTION 4: OPERATIONS

## Operation Safety

Your safety is important! Please follow the warnings below during this entire section:

### **WARNING**

To avoid serious personal injury, read and become familiar with the entire instruction manual before using this wide belt sander.

### **WARNING**

Damage to your eyes, lungs, and ears could result from failure to wear safety glasses, a dust mask, and hearing protection while sanding with this machine.

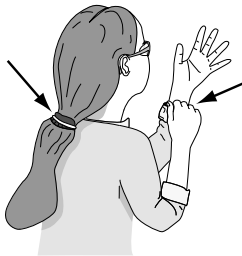

### **WARNING**

Loose hair and clothing could get caught in machinery and cause serious personal injury. Keep loose clothing rolled up and long hair tied up and away from machinery.

## Choosing Sandpaper

The grit you choose will depend on the type of work, the species of wood and the stage of finishing. Below is a chart that groups abrasives into different categories and shows which grits fall into each-one. We recommend using aluminum oxide sanding belts for the best results.

Grit	Type
60	Coarse
80-100	Medium
120-150	Fine

The general rule of thumb is to sand a workpiece with progressively higher grit numbers, with no one grit increase of more than 50; however, the type of wood and desired finish will determine the best grit to use.



# Table Movement

Table height can be adjusted manually or with the digital key pad and motor (see **Figure 15**).

**Manual Table Movement:** Turn the handwheel located under the front of the infeed table for manual table positioning.

**Motorized Table Movement:** Press the TABLE UP or TABLE DOWN key once for motorized table positioning in 0.005" (0.1mm) increments.

**Numerical Key Pad:** Enters the position of sanding depth.

**Metric or Standard Key:** Press and hold the SET button for 3 seconds to calibrate display at the current board thickness; or press and hold key for 10 seconds to toggle the display between metric and standard measurement.

**Table Start Key:** Moves table to a preset sanding depth.

**Table Stop Key:** Stops table movement immediately.

**Digital Display:** Shows final table sanding depth.

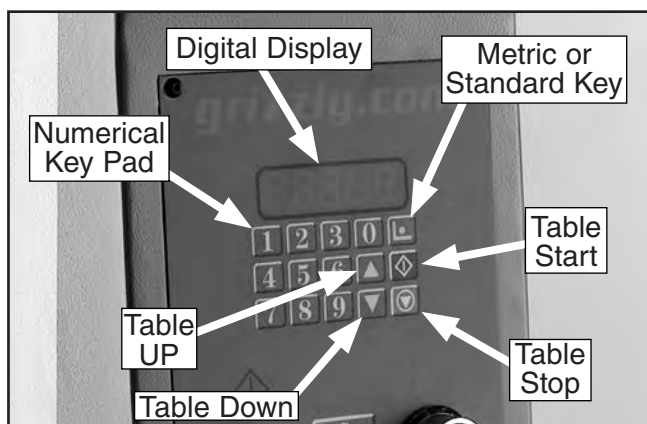

**Figure 15.** Keys for adjusting the table height.

## **NOTICE**

The thickness gauge is pre-calibrated from the factory; however, correct calibration should be verified.

# Adjusting Feed Rate

The dial attached to the side of the feed belt gear box (**Figure 16**) adjusts the feed rate of the sander.

**Note:** *Never adjust the feed rate dial unless the conveyor belt is running, otherwise you can damage the control.*

**Changing Feed Rate:** Turn the dial clockwise to decrease the feed rate and counterclockwise to increase it.

**Determining Ideal Feed Rates:** Softwoods typically require a faster feed rate than hardwoods; however, there is no definitive rule to follow when determining the best feed rate. As a general rule, always start with the slowest feed rate and work your way up. We always recommend testing the feed rate using scrap wood similar to your workpiece. Be sure to monitor the amperage meter when adjusting the feed rate. Decrease the feed rate if the load begins to slow the motor RPM.

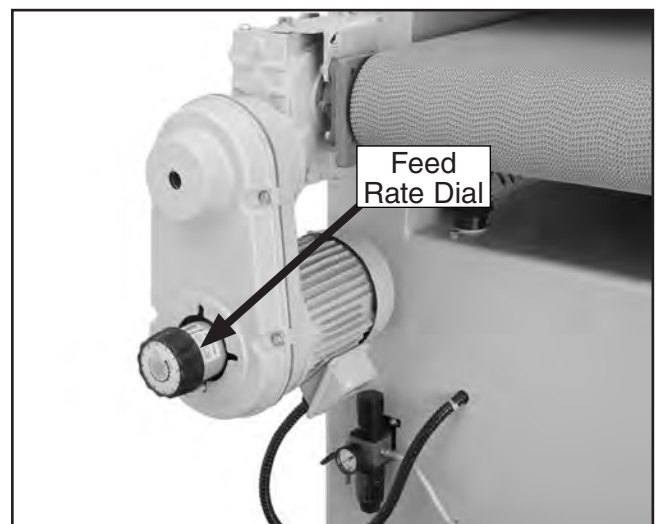

**Figure 16.** Feed rate dial.



# Amp Draw Meter

The amperage draw meter (**Figure 17**) is located above the control panel. Use the meter to monitor the amperage draw on the machine while performing sanding operations.

As a general rule, always start with a small load and work your way up. **DO NOT** work your machine to its maximum load, where you can hear the motor lose RPM; instead, make multiple passes or install a coarser grit paper.

Amp load will be directly affected by many factors such as feed rate, depth of cut, wood type, sandpaper grit, and workpiece width. If the amp load is in the red load range, the machine is overloaded and motor damage will occur. Keep the amp load in the green range during operation.



**Figure 17.** Typical amp draw meter and load chart.

## **NOTICE**

**DO NOT VOID WARRANTY!** Keep the amp draw within the **GREEN** load range shown on the **AMP LOAD CHART**. If you operate the sander in the **RED** load range, capacitor or motor failure will occur and will not be covered under warranty.





# Sanding Workpiece

Typically, no more than 0.5mm (approx.  $\frac{1}{64}$ " ) of material is removed during each pass. Attempts to remove too much material can cause jamming, wood burning, rapid paper wear or tearing, poor finish, short motor life, and belt slippage.

The following is the correct sanding operating procedure:

1. Put on safety glasses, a dust mask, and hearing your protection!
2. Turn **ON** the dust collector.
3. On the initial pass, set the table to approximately 0.25" greater than the thickness of the workpiece.

**Note:** This initial pass setting reduces the chance of overloading the sander on undetected high points on the workpiece.

4. Continue to raise the table 0.0625" between each successive pass until the sander begins to sand the workpiece.

## NOTICE

It may be necessary to send wide stock through the sander two or three times between table height adjustments. This reduces the likelihood of burning the wood if there is a high spot.

# Platen Adjustment

Your sander is equipped with an adjustable felt platen and graphite slip for those extra sensitive sanding operations. The platen position allows for 3 basic types of sanding. These different positions can be adjusted by rotating the height lever shown in **Figure 18**.

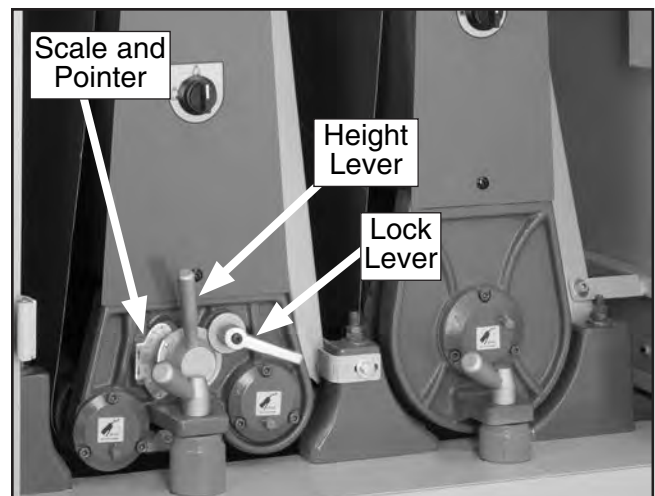

**Figure 18.** Platen height controls.

The three basic platen positions:

**Platen Up:** The platen is raised above the level of the sanding rollers. This position allows the front roller to remove large amounts of material quickly, but leaves a rough finish. The best belt grit for this position is #100 or coarser.

**Platen Even:** The platen is set even with the sanding rollers. The rollers work together with the platen to produce intermediate/final finishing. The best belt grit for this position is #100-#180.

**Platen Down:** The platen is lowered below the sanding rollers. The majority of the work is accomplished by the platen pressure on the workpiece. The result is a smooth, flat finish. The best belt grit for this position is #180 or finer. Avoid lowering the platen more than 0.2 mm below the sanding belt rollers, or you will prematurely wear the platen.

**Note:** The platen scale is broken down in millimeter increments.





# SECTION 5: ACCESSORIES

---

---

## H3741 30 HP Rotary Phase Converter

Add 3-phase, multi-motor capability to your single-phase electrical supply. Operate single or multiple motors, transformers, and resistance loads at 100% power and 95% efficiency while saving big dollars at cheaply metered, single-phase electrical rates. Complete step by step instructions are furnished along with complete wire and fusing requirements for various motor loads. Each model operates up to twice its nameplate rating in a mixed-motor load. On heavily loaded or hard-start applications, such as high-speed geared-head lathes and air conditioning compressors, the nameplate rating of the converter you choose should be 2 to 3 times the HP of the most heavily loaded motor. See the individual 3-phase machine pages for phase converter recommendations. For application assistance, please call our technical support at (570) 546-9663.



**Figure 19.** Rotary phase converter.

## H2845 Cleaning Pads

Cleaning pads are the perfect accessory for wide belt sanders. Simply set the conveyor table to height and feed the pad through to “unload” a dirty sanding belt. Regular cleaning greatly increases the lifespan of sanding belts. Check with the current Grizzly catalog or [www.grizzly.com](http://www.grizzly.com) for more details.

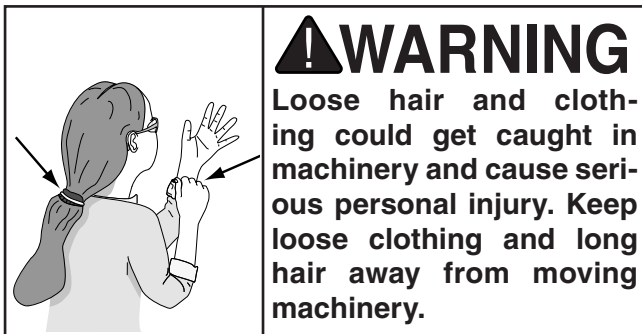
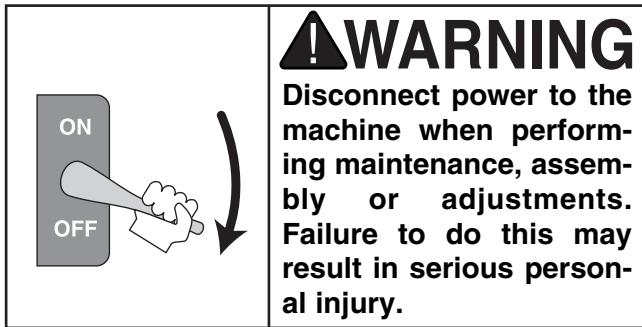

**Figure 20.** Sanding belt cleaning pad.

# SECTION 6: MAINTENANCE

## General

Your safety is important! Please follow the warnings below during this entire section:



## Schedule

The following items should be checked each time the sander is used:

- Loose mounting bolts.
- Damaged sanding belt.
- Worn or damaged wires.
- Water collection cups filled with water.
- Dust trap.
- Safety features.
- Any other condition that could hamper the safe operation of this machine.

## Weekly

Grease the grease fittings located on the feed belt roller axles and the sanding belt roller axles. They are identified with yellow labels.

## Monthly

Apply a generous amount of grease to the table elevation screws. Be sure to recover the adjustment screws with the dust covers when finished.

Remove the lower side panel to access the table lifting mechanism. Apply grease to the chain and gears associated with the table lifting mechanism. Be careful to not get grease on the V-belts. This could cause them to slip off of the pulleys.

## After the First 100 Hours

The oil inside the conveyor gear reducer should be replaced after the first 100 working hours of operation. We recommend 90 Wt. gear oil.

## Every 2500 Hours

After the first conveyor gear reducer oil change, replace the oil after every 2500 working hours of operation. We recommend 90 Wt. gear oil.



# Sanding Belts

You can greatly increase the lifespan of your sanding belts if you clean them often. As mentioned on **Page 26**, cleaning pads are the fastest way to remove saw dust build-up.

## Air System

The air system is durable and reliable; however, components do wear with age. If you suspect that an item in your air system may be having problems, see the **Air System Diagram** on **Page 39**.

- Adjust regulator to 75 PSI.
- Carefully inspect all air lines for cracks, tears or hardening. Replace faulty hoses.
- Check the air connections for leaks. A small amount of soapy water in a questionable area will bubble if there is a leak.
- Make sure lines are not clogged. Remove a questionable line and blow through it as a test.

### CAUTION

If a component in the air system is malfunctioning, bleed all air from the system, and fix the problem before you resume sanding.

# Dust and Water Traps

There are three traps on this wide belt sander. One water trap is attached to the bottom of the air regulator, and two dust traps are attached on the air diaphragm assemblies. Cleaning is easy, with the system under air pressure, you can push the lower drain valve and empty regulator water trap (**Figure 21**). Replace the internal white moisture filters yearly. To empty the dust trap bowls, relieve the air pressure and then unscrew and empty the bowls (**Figure 22**). DO NOT allow the water trap and dust bowls to become full.

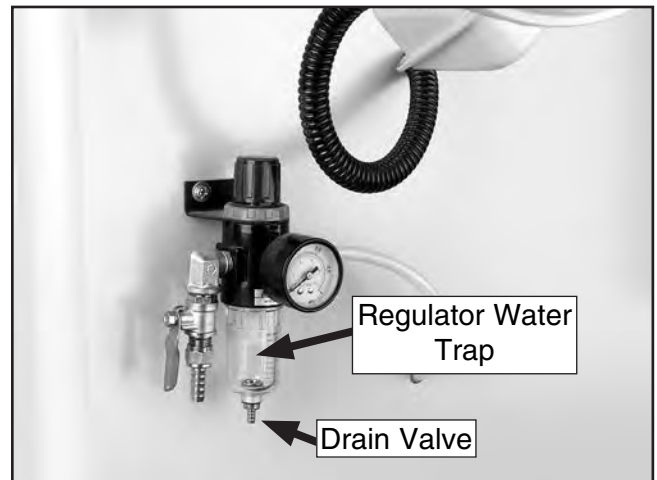

**Figure 21.** Water trap on the regulator.

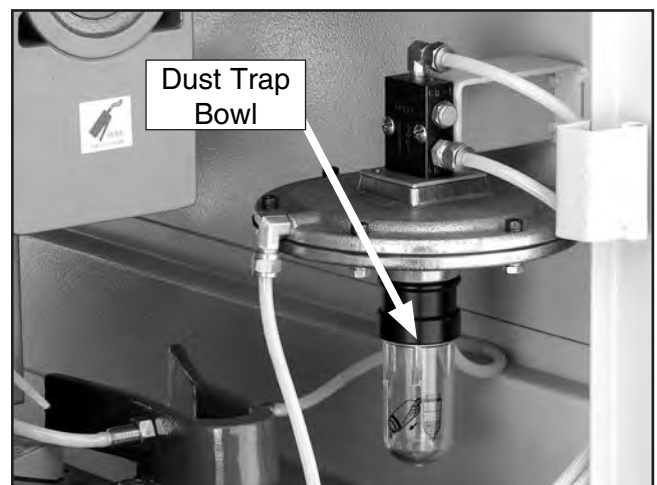

**Figure 22.** Unscrew the clear canister to empty the air line dust trap.



# SECTION 7: SERVICE

## Table Calibration

### **NOTICE**

The digital thickness gauge has been calibrated at the factory and should require no further adjustment. However, we recommend verifying its accuracy.

Use the first board fed through the sander to test the accuracy of the digital thickness gauge.

#### To calibrate the digital thickness scale:

1. Using a properly set-up planer, plane a board to uniform thickness.
2. Lower the sander table far enough to place the planed board under the sander roller.
3. Manually raise the table until the board just touches the sanding roller.
4. Remove the board without changing the table height. This ensures the table will be properly adjusted for the first sanding pass.
5. Run the board through the sander several times at the initial height setting. Manually raise the table 0.020" and pass the board through the sander several more times. Monitor the amperage meter and the resulting load on the sander.
6. Measure the thickness at various points around the board using a precise micrometer or set of calipers. Continue sanding the board at that height until the average thickness measurement is within  $\pm 0.003$ ".

**Note:** *These final passes should be done without adjusting the table height. This ensures the most consistent average thickness.*

7. Observe the digital display read-out, it should indicate the average thickness of the sanded wood.

—If it does, the sander is properly calibrated and accurate to the nearest 0.005".

—If it does not, you must recalibrate the digital thickness scale.

#### To recalibrate the digital thickness scale:

1. Without moving the table height, enter the numerical measurement of the average thickness of the sanded wood into the digital key pad on the control panel.

**Note:** *The average thickness of the sanded wood should now be flashing on the digital read-out.*

2. Press and hold the  key until the display stops flashing. The sander is now correctly calibrated.

## Platen Service

#### To replace the platen felt and graphite pad:

1. DISCONNECT THE SANDER FROM THE POWER SOURCE!
2. Open the left access door, and use the platen tool, as shown in **Figure 23**, to remove the platen.
3. Replace platen felt pad and graphite pad.
4. Reinsert the platen until it stops.
5. Close the access door.



**Figure 23.** Removing platen.



# Brake Service

Tools Needed:	Qty
14mm Open End Wrench .....	1
Small Snap Ring Pliers .....	1
6mm Hex Wrench.....	1
#2 Phillips Screwdriver .....	1

Eventually the brake pads will wear out. Checking and replacing these is a simple project that can be done in the shop, with the exception of having the rotor resurfaced on a lathe.

## To check the brake pads:

1. **Disconnect the sander from the power source and remove air pressure completely!**
2. Remove the four screws that secure the access panel on the right-hand side of the machine.
3. The brake caliper is located underneath the rotor in **Figure 24**, which is attached to the motor arbor.

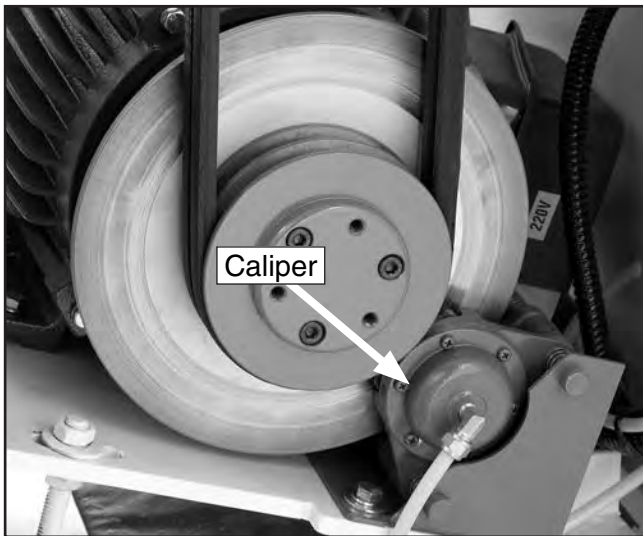

**Figure 24.** Disc brake.

4. The brake pads consist of a metal plate with a composite pad. With a fine ruler, measure the thickness of the composite pad only. If one of the pads is below  $\frac{1}{8}$ " (approx. 3mm), replace both.

## To replace the brake pads:

1. **Disconnect the sander from the power source and remove air pressure completely!**
2. Remove the nuts from the two mounting bolts and the two snap rings on the mounting pins behind the bracket.
3. Pull the mounting pins out of the caliper bracket and remove the air line from the caliper. The caliper should now be able to be removed.
4. Disassemble the brake caliper and remove the cap screws securing the brake pads.
5. Remove the brake rotor and have it professionally resurfaced at an automotive machine shop if it has gouges in it. If visible cracks are present in the brake rotor, replace it with a new one. Remove oil and dirt from the rotor with automotive brake cleaner. Once clean, only handle the rotor with a dry rag and install exactly the reverse of removal.
6. Install new brake pads, mount the caliper and reconnect the air line.
7. Test the safety shutdown operation by running the sander and pressing the emergency stop controls.





# Oscillation Timing

## **NOTICE**

The oscillation adjustments have been performed at the factory and should require no further attention. However, we recommend verifying the settings.

When the oscillation is correctly adjusted, the sanding belt oscillates to the left and to the right at the same speed. If the sanding belt makes contact with a limit switch, as shown in **Figure 25**, the emergency braking system will activate and stop the sander immediately.

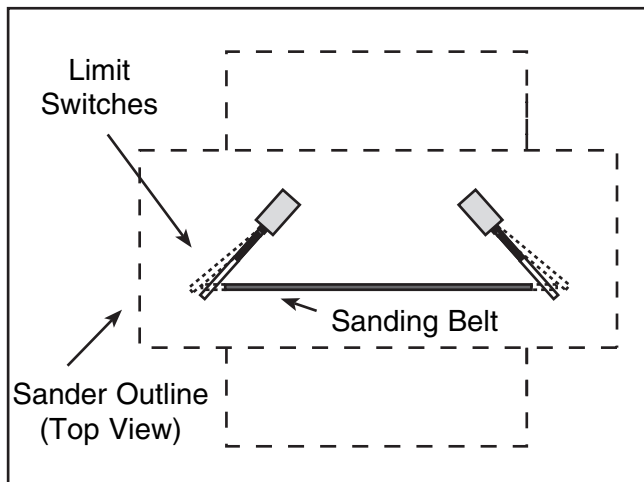
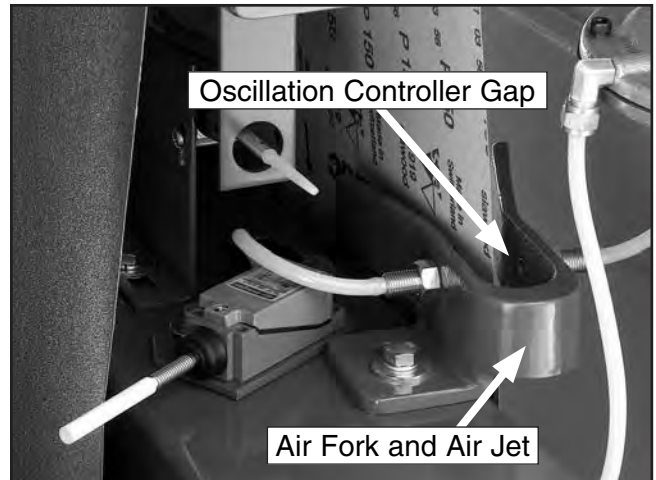

**Figure 25.** Improper oscillation.

### To check the sanding belt oscillation:

1. Be sure the sanding belt is properly installed and the belt tension knob and air supply are **ON**.
2. Turn **ON** the sanding belt.
  - If the belt oscillates without contacting the limit switches, but the oscillation time to the left and right are **NOT** equal, proceed to **Step 5**, on **Page 33**.
  - If the belt tracks away from the air fork and air jet, colliding into the limit switch, continue with **Step 3**.

3. An adequate stream of air through the air fork gap (**Figure 26**) is essential for proper oscillation. If the jet of air is weak through the gap, the belt will track away from the controller and into the limit switch on the opposite end of the roller. The pivot action of the upper roller, and the resulting oscillation of the belt, are dependent upon adequate airflow through the air fork gap.



**Figure 26.** Oscillation components.

### To set the correct amount of airflow through the air fork gap:

1. Remove the sanding belt and turn the belt tension knob to the tensioned position.
2. Loosen the lock nut on the airflow adjustment knob (**Figure 27**).
3. Turn the airflow adjustment knob (**Figure 27**) clockwise until the airflow is completely **OFF**. The upper roller should pivot to the right.
4. Slowly turn the airflow adjustment knob counterclockwise, and continue turning up the air pressure until the roller pivots to the left.

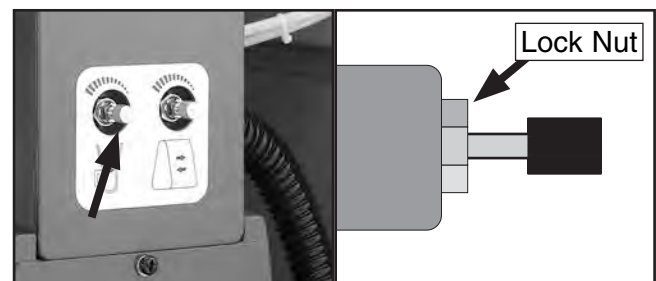

**Figure 27.** Airflow adjustment knob.



5. Tighten the lock nut (**Figure 27**) to secure the airflow adjustment knob.
6. Restrict the airflow across the air fork gap with a scrap piece of wood. You should notice the roller pivot to the right. When the stick is removed, the roller should pivot back to the left.
7. Test the oscillation by running the sander. Make note of the time it takes for the belt to oscillate from left-to-right and from right-to-left.

When correctly timed, the oscillation should take a similar amount of time to oscillate.

—If the oscillation time to the **right** is 2 seconds, but the oscillation time to the **left** is longer, loosen the oscillation adjustment knob (**Figure 28**) and move it to the **left** until proper tracking is achieved. Tighten down the oscillation adjustment knob when satisfied.

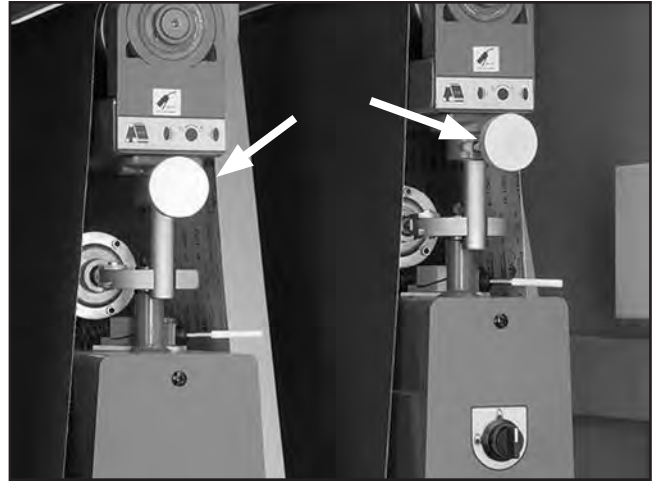

**Figure 28.** Oscillation adjustment knobs.

—If the oscillation time to the **left** is 2 seconds, but the oscillation time to the **right** is longer, loosen the oscillation adjustment knob and move it to the **right** until proper tracking is achieved. Tighten the oscillation adjustment knob when satisfied.

8. Continue to the next page to adjust the oscillation speed.





# Oscillation Speed

The oscillation speed of the sanding belt is adjustable. Different oscillating speeds yield different sanding results. We recommend trying various speeds on a scrap piece of wood similar to the final workpiece.

## To adjust the oscillation speed:

1. Loosen the lock nut on the speed control adjustment knob (**Figure 29**).

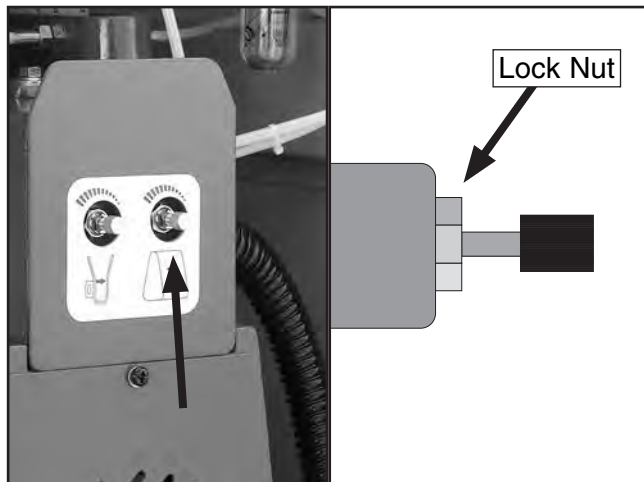

**Figure 29.** Speed control adjustment knob.

2. Turn the knob clockwise to decrease the oscillation speed and counterclockwise to increase it.
3. Tighten the lock nut loosened in **Step 1** to secure the knob.

# Table Parallelism

## ***NOTICE***

The table has been adjusted at the factory and should require no further attention. However, we recommend verifying that it is parallel with the sanding roller.

The corners of the table can be independently adjusted up or down. By disconnecting the chain and turning the pertinent table elevation screw sprocket, (**Figure 30**) table parallelism can be achieved.

Adjusting the table parallelism can be a very tedious task that takes a great amount of patience. DO NOT adjust the table unless you are having trouble sanding your workpiece to a uniform thickness.

If a table adjustment is needed, take precise notes on the positioning of the table elevation screws. This will allow the original setting to be re-established.

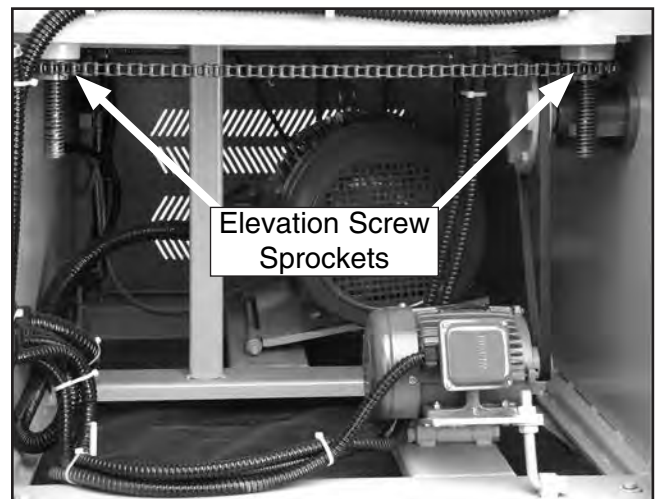

**Figure 30.** View of elevation screw sprockets.



### To adjust the table parallelism:

1. Pass a 37" wide board through the sander until the **entire** surface of the board is making contact with the sanding belt.
2. Measure the thickness of the board at various points around the edge.
3. If there is a variation of thickness, the table can be adjusted accordingly.
4. DISCONNECT THE SANDER FROM THE POWER SOURCE!

—For minor adjustment, loosen the table mounting bolts shown in **Figure 31** and rotate the elevation screw flange.

—For major adjustment, mark the chain location on all sprockets, remove the chain from the sprocket to be adjusted, and turn the sprocket counterclockwise to raise the table. One quarter of a turn raises or lowers an elevation screw approximately 0.020"

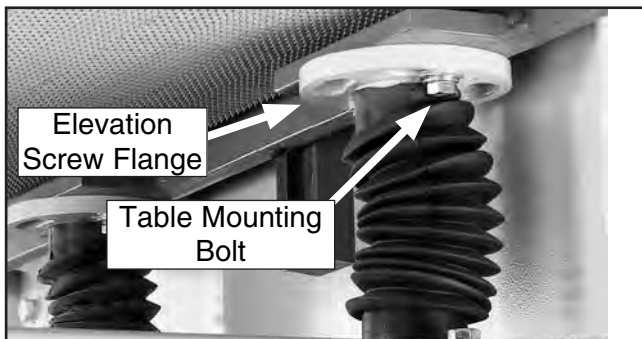

**Figure 31.** Table mounting bolts.

## **NOTICE**

**When adjusting the left front elevation screw, make the same adjustment to the left rear elevation screw. This ensures the height from the front to the back of the table remains unchanged. Do the same when adjusting the right elevation screws.**

5. Reinstall the chain, tighten the bolts, and test the machine.

# Pressure Rollers

### To adjust the pressure rollers:

1. DISCONNECT THE SANDER FROM THE POWER SOURCE!
2. Plane a 6' long 2x4 to a uniform thickness and cut it in half. Place one board along the length of the feed belt on the right-hand side and place the other board on the left-hand side.
3. With the sanding belt tensioned (**Figure 32**), move the sanding rollers by hand and manually raise the table until you hear the sandpaper just contact the surface of the wood. DO NOT continue to raise the table beyond that point.

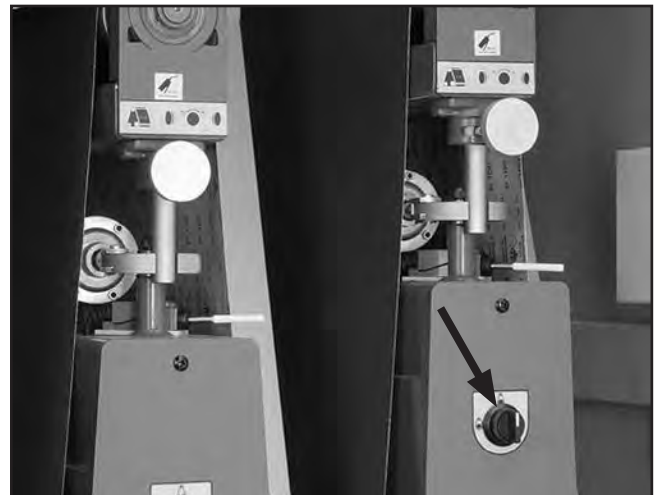

**Figure 32.** Belt tension knob.

4. Connect the sander to the power source and make note of the reading on the digital display. Then manually lower the table 0.020" to 0.030". This is how much lower the infeed pressure roller should be set when compared to the sanding surface of the sanding roller.
5. DISCONNECT THE SANDER FROM THE POWER SOURCE!



- Loosen the roller lock nuts (**Figure 33**) on the infeed pressure roller. Turn the adjustment studs (**Figure 33**) to lower the pressure roller until it just touches the board.

**Note:** *DO NOT continue to lower the roller beyond that point.*

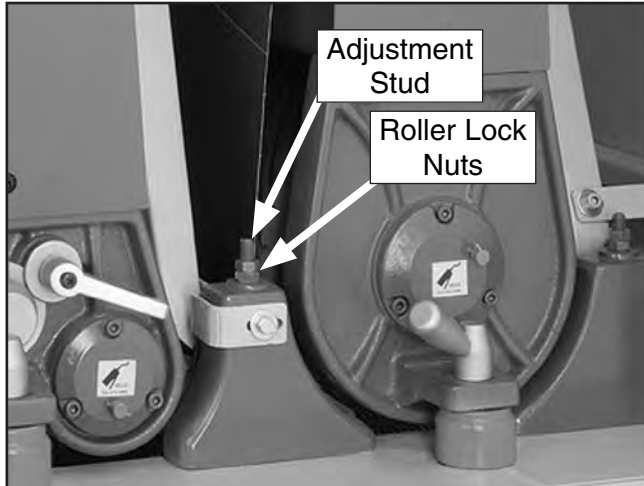

**Figure 33.** Pressure roller adjustment location.

- Tighten the roller lock nuts and recheck your settings.
- Connect the sander to the power source and make note of the reading on the digital display. Then manually lower the table an additional 0.020" to 0.030". This is how much lower the outfeed pressure roller should be set when compared to the height of the infeed roller.
- Loosen the roller lock nuts on the outfeed pressure roller. Turn the adjustment bolts to lower the pressure roller until it just touches the board.

**Note:** *DO NOT continue to lower the roller beyond that point.*

- Tighten the roller lock nuts and recheck your settings.

**Note:** *Variables such as feed rate, depth of the cut, and the type of sanding belt can play a big part in determining the proper amount of downward pressure exerted by the rollers. Some experimentation may be necessary to achieve the desired results. However, under no circumstances should the pressure rollers be set even, or higher than, the sanding roller.*



## V-Belt Adjustment

**To adjust either V-belt:**

- DISCONNECT THE SANDER FROM THE POWER SOURCE!
- Loosen the lock nut (**Figures 34 & 35**).

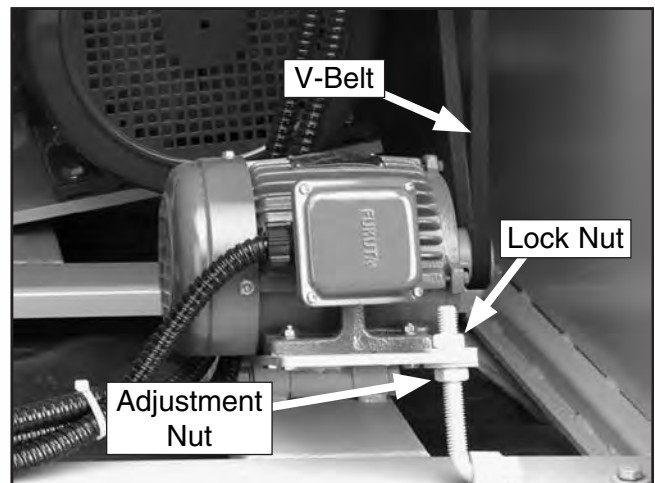

**Figure 34.** Table elevation V-belt.

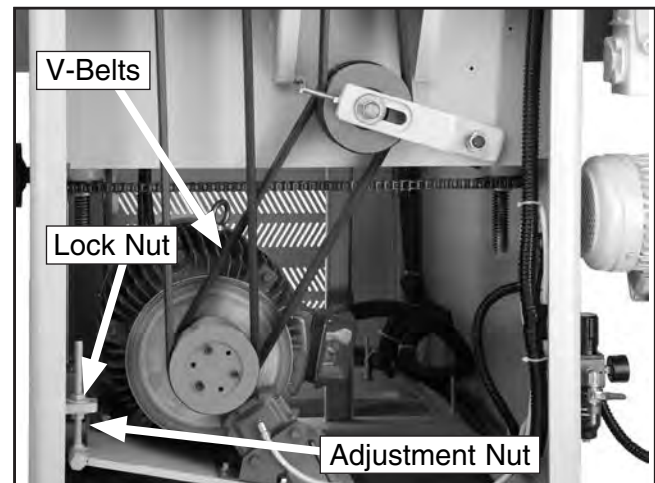

**Figure 35.** Sanding drum V-belts.

- Turn the adjustment nut up or down until the V-belts deflect 1" off of center when pushed with your finger.
- Retighten the lock nut.

# Conveyor Belt Replacement

## Tools Needed: Qty

Make sure that you have a lifting device or another person to help in table removal.

9 mm Hex Wrench.....	1
19 mm Combination Wrench.....	1
12 mm Combination Wrench.....	1
14 mm Combination Wrench.....	1
#2 Phillips Screwdriver .....	1
8' 2x4s .....	2
Permanent Marker .....	1

To remove the conveyor belt use **Figure 37** and follow the steps below:

1. Raise the table up so the conveyor belt is approximately two-inches away from the sanding roller or platen, and then **DISCONNECT THE SANDER FROM THE POWER SOURCE!**
2. Remove the gearbox mounting bracket, and with an assistant's help, slide the motor and gearbox from the roller shaft and lower it to the floor.  
  
**Note:** Do not loosen the two vibration dampener washers shown in **Figure 37**.
3. Remove two table height limit switches.
4. Remove both lower access panels.
5. Remove the left and right table guides.
6. Using a permanent marker, mark all four lead screw flange positions (**Figure 36**), and remove all hex bolts from the flanges.

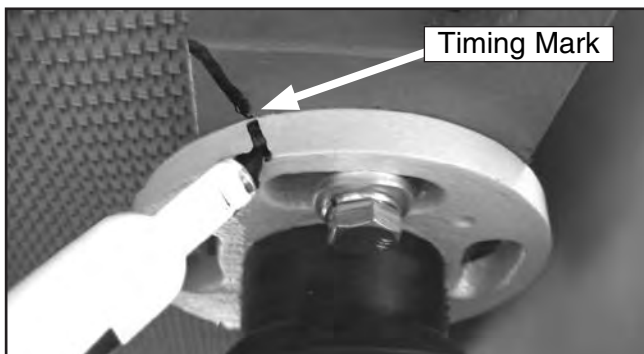

**Figure 36.** Marking lead screw for reassembly.

7. Insert two 2x4 x 8' wooden studs under the table to support the table, and then both people must lift the table slightly and move it out of the rear of the machine.
8. Disconnect the limit switch, remove all mounting screws, and remove the emergency stop push-panel assembly.
9. Turn both tracking adjustment bolts counter-clockwise five turns, remove one roller support, and slide the drum out of the table assembly.
10. Remove the old conveyor belt, inspect rollers, bearings, table for wear and replace as required.
11. Install the new conveyor belt. **Note:** *The belt is non-directional.*
12. Install the front roller, the roller support, and turn both tracking adjustment bolts clockwise equally so the conveyor belt becomes taut and does not hang loose. **DO NOT OVERTIGHTEN** the belt.
13. With a helper, install the table from the rear in a similar fashion as it was removed.
14. Install the table guides and the left and right lower access panels.
15. Align the lead screw flanges with the marks made in **Step 6**, and install the hex bolts.
16. Install the table height limit switches so the upper switch clicks when the conveyor surface is 1/4" away from the sandpaper, and the lower switch clicks when the conveyor table is 1/4" higher than its lowest position. Make sure that you test your settings with the hand wheel manually so you don't crash the table if incorrectly set the first time around.
17. With a helper, install the gearbox, vibration dampener washers, and mounting bracket.
18. Install the emergency stop pushpanel assembly and the limit switch.
19. Start the conveyor motor and turn the conveyor tracking bolts as required until the conveyor belt tracks straight without loading up on one side of the table.



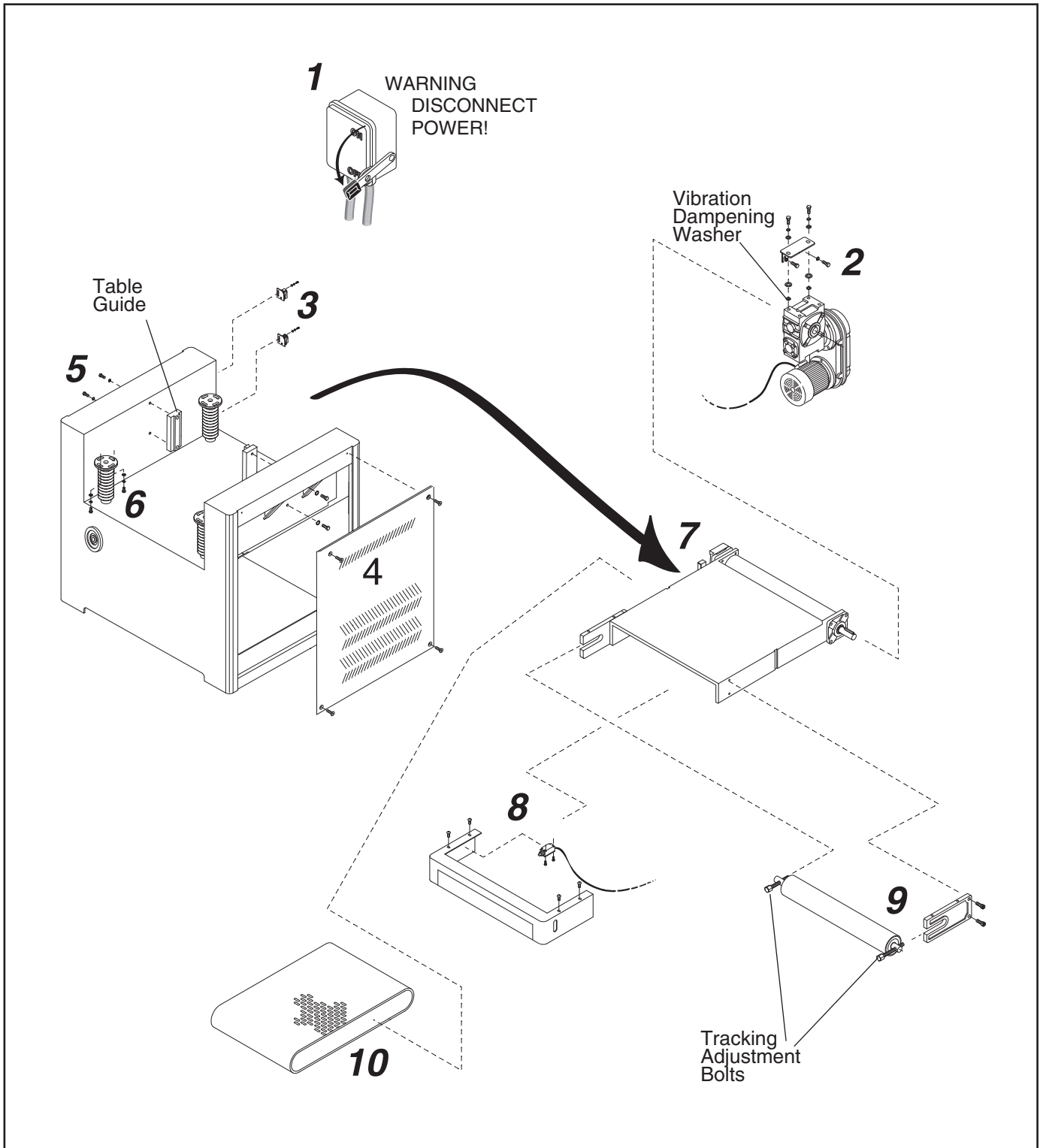

**Figure 37.** Conveyor belt removal sequence.





# Feed Belt Tension

Tools Needed:	Qty
20mm Wrench or Socket.....	1
#2 Phillips Screwdriver .....	1

## To adjust the feed belt tension:

1. DISCONNECT THE SANDER FROM THE POWER SOURCE!
2. Find the adjustment ports in the safety guard (**Figure 38**) at the front end of the feed table.
3. Turn both left and right adjustment bolts (**Figure 38**) clockwise equally to increase tension.

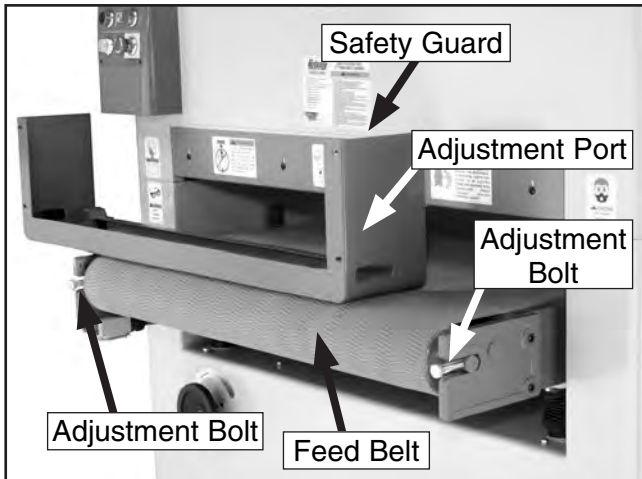

**Figure 38.** Feed belt tension adjustment bolts.  
**Note:** Safety guard removed for clarity.

4. When tensioned properly you should not be able to lift the feed belt off of the table surface or slide it back and forth.

## **!WARNING**

**DO NOT sand boards with the guard removed. Failure to follow this warning could result in serious personal injury.**

# Feed Belt Tracking

Tools Needed:	Qty
6mm Hex Wrench.....	1

## **NOTICE**

**Adjust the feed belt tension before adjusting the feed belt tracking.**

## To adjust the feed belt tracking:

1. Turn the feed belt **ON**.
2. If the feed belt is tracking to the **right** side of the table, turn the **right** adjustment bolt (**Figure 38**) clockwise.
3. If the feed belt is tracking to the **left** side of the table, turn the **left** adjustment bolt clockwise.

**Note:** The edge of the feed belt should just touch the guide wheels as shown in **Figure 39**.

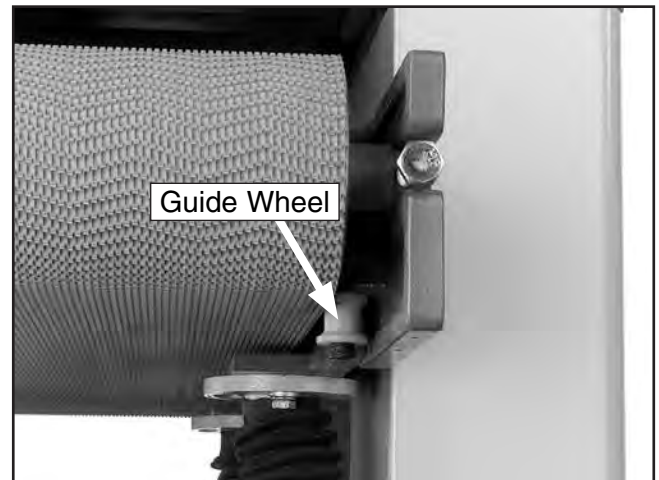

**Figure 39.** Guide wheels.

4. Run the feed belt for 3-5 minutes and recheck the tracking.
5. If the belt is still tracking correctly, replace the safety guard removed in the previous subsection.



# Air System Diagram

- A. Shop Compressor
- B. Air Pressure Regulator
- C. Emergency Brake Solenoid
- D. Emergency Brake
- E. Air Distribution Manifold
- F. Airflow Adjustment Knob (Oscillation Timing)
- G. Speed Control Adjustment Knob (Oscillation Speed)
- H. Oscillation Controller Air Fork
- I. Oscillation Timing Piston and Diaphragm Assy.
- J. Oscillation Speed Control Piston
- K. Belt Tension Control Piston
- L. Belt Tension Control Switch
- M. Emergency Stop Button Switch
- N. Emergency Stop Push Brake Switch
- O. Left Belt Limit Switch
- P. Right Belt Limit Switch
- Q. Belt Tension Limit Switch
- R. Emergency Brake Contactor

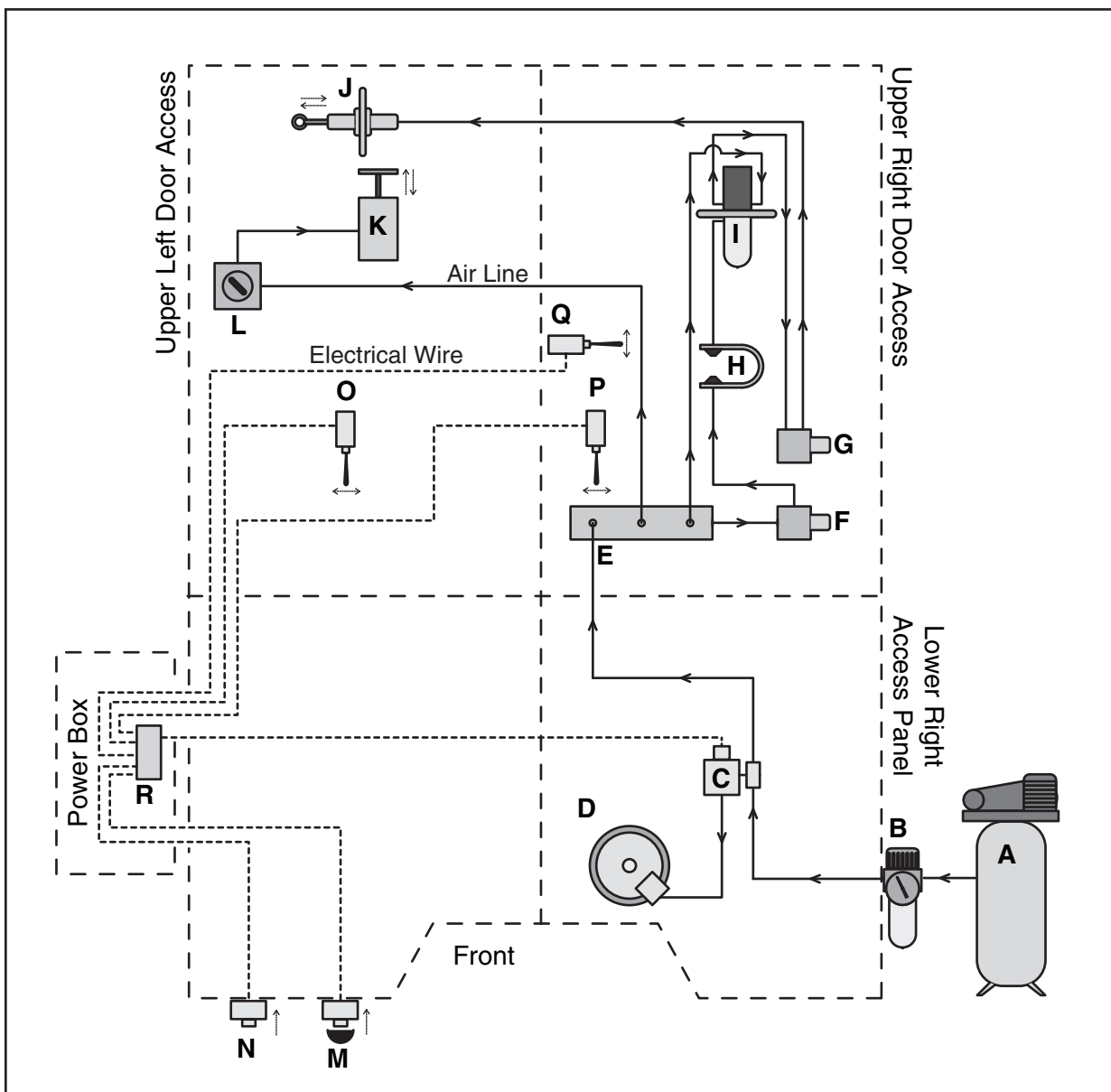



# Troubleshooting

SYMPTOM	POSSIBLE CAUSE	CORRECTIVE ACTION
Motor will not start.	<ol style="list-style-type: none"> <li>1. Limit switch or emergency stop is at fault.</li> <li>2. Low voltage.</li> <li>3. Open circuit in motor or loose connections.</li> </ol>	<ol style="list-style-type: none"> <li>1. Correct situation that caused limit switch to engage, reset the emergency stop button.</li> <li>2. Check power line for proper voltage.</li> <li>3. Inspect all lead connections on motor for loose or open connections.</li> </ol>
Motor will not start; fuses or circuit breakers blow.	<ol style="list-style-type: none"> <li>1. Short circuit in line cord or plug.</li> <li>2. Short circuit in motor or loose connections.</li> <li>3. Incorrect fuses or circuit breakers in power line.</li> </ol>	<ol style="list-style-type: none"> <li>1. Inspect cord or plug for damaged insulation and shorted wires.</li> <li>2. Inspect all connections on motor for loose or shorted terminals or worn insulation.</li> <li>3. Install correct fuses or circuit breakers.</li> </ol>
Motor overheats.	<ol style="list-style-type: none"> <li>1. Motor overloaded.</li> <li>2. Air circulation through the motor restricted.</li> </ol>	<ol style="list-style-type: none"> <li>1. Reduce load on motor.</li> <li>2. Clean out motor to provide normal air circulation.</li> </ol>
Motor stalls (resulting in blown fuses or tripped circuit).	<ol style="list-style-type: none"> <li>1. Short circuit in motor or loose connections.</li> <li>2. Low voltage.</li> <li>3. Incorrect fuses or circuit breakers in power line.</li> <li>4. Motor overloaded.</li> </ol>	<ol style="list-style-type: none"> <li>1. Inspect connections on motor for loose or shorted terminals or worn insulation.</li> <li>2. Correct the low voltage conditions.</li> <li>3. Install correct fuses or circuit breakers.</li> <li>4. Reduce load on motor.</li> </ol>
Machine slows when operating.	<ol style="list-style-type: none"> <li>1. Feed rate too high.</li> <li>2. Depth of cut too great.</li> </ol>	<ol style="list-style-type: none"> <li>1. Feed workpiece slower.</li> <li>2. Reduce depth of cut.</li> </ol>
Loud, repetitious noise coming from machine.	<ol style="list-style-type: none"> <li>1. Pulley set screws or keys are missing or loose.</li> <li>2. Motor fan is hitting the cover.</li> <li>3. V-belt is defective.</li> </ol>	<ol style="list-style-type: none"> <li>1. Inspect keys and set screws. Replace or tighten if necessary.</li> <li>2. Tighten fan or shim cover.</li> <li>3. Replace V-belt. Refer to the <b>Maintenance</b> section.</li> </ol>
Machine is loud, overheats or bogs down in the cut.	<ol style="list-style-type: none"> <li>1. Excessive depth of cut.</li> <li>2. Dull or dirty sanding belt.</li> </ol>	<ol style="list-style-type: none"> <li>1. Decrease depth of cut.</li> <li>2. Replace or clean sanding belt.</li> </ol>
Rounded workpiece edges.	<ol style="list-style-type: none"> <li>1. Excessive depth of cut.</li> </ol>	<ol style="list-style-type: none"> <li>1. Reduce depth of cut.</li> </ol>
Uneven thickness from left to right of board.	<ol style="list-style-type: none"> <li>1. Feed table not parallel to sanding roller.</li> <li>2. Conveyor belt is worn.</li> </ol>	<ol style="list-style-type: none"> <li>1. Adjust the table.</li> <li>2. Replace conveyor belt.</li> </ol>
Workpiece slips on feed belt.	<ol style="list-style-type: none"> <li>1. Pressure rollers set too high.</li> <li>2. Dirty conveyor belt.</li> <li>3. Conveyor belt is worn.</li> </ol>	<ol style="list-style-type: none"> <li>1. Lower pressure rollers.</li> <li>2. Clean conveyor belt.</li> <li>3. Replace conveyor belt.</li> </ol>
Straight strip of notches on workpiece.	<ol style="list-style-type: none"> <li>1. Pressure rollers are dirty or damaged.</li> </ol>	<ol style="list-style-type: none"> <li>1. Clean or repair pressure rollers.</li> </ol>
Snake shaped marks on workpiece.	<ol style="list-style-type: none"> <li>1. Sanding belt damaged or dirty.</li> </ol>	<ol style="list-style-type: none"> <li>1. Clean or replace sanding belt.</li> </ol>

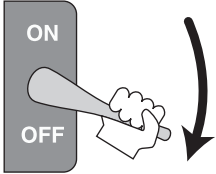

## ⚠ WARNING

**For your safety, turn the power switch off and disconnect the sander from the power source and the air supply before starting the applicable troubleshooting.**



# Troubleshooting

SYMPTOM	POSSIBLE CAUSE	CORRECTIVE ACTION
Lines across width of workpiece.	1. Sanding belt seam is open or damaged.	1. Repair or replace sanding belt.
Glossy spots or streaks on workpiece.	1. Worn sanding belt. 2. Rear pressure roller too low.	1. Replace sanding belt. 2. Raise rear pressure roller. <b>(See warning in Pressure Roller section!)</b>
Sanding belt clogs quickly.	1. Sanding belt grit too small for particular job. 2. Excessive depth of cut. 3. Wood is too moist.	1. Replace with a coarser grit sanding belt. 2. Reduce depth of cut. 3. Allow wood to dry out.
Sanding belt does not tension correctly; rollers slip under belt.	1. Low air pressure. 2. Air leaks in system.	1. Adjust air pressure to 75 PSI at primary regulator. 2. Inspect all hoses and connections for leaking air; use water on suspected area to detect bubbles.
Sanding belt runs off to one side, stopping the sander.	1. Air eye fork clogged. 2. Oscillation return valve closed. 3. Oscillation timing incorrect.	1. Clean the intake hole on the air eye fork. 2. Open valve. 3. Adjust oscillation timing.
Sanding belt will not start.	1. Sanding belt is not tensioned. 2. Limit switches engaged. 3. Emergency stop plate engaged.	1. Tension sanding belt. 2. Center sanding belt so it is not touching the limit switches. 3. Make sure emergency stop switch is released.
Poor, non-aggressive sanding results.	1. Worn sanding belt. 2. Sanding belt loaded with sawdust.	1. Replace sanding belt with a new one. 2. Clean sanding belt to unload sawdust.
Conveyor belt not tracking in center.	1. Conveyor rollers moved out of adjustment.	1. Re-adjust conveyor rollers.
Conveyor belt slipping.	1. Conveyor rollers have incorrect tension. 2. Conveyor rollers contaminated with dirt or dust.	1. Adjust conveyor rollers to place more tension on the workpiece. 2. Clean conveyor rollers.
Emergency brake stops slow.	1. Air pressure incorrect. 2. Air leak in system. 3. Brake rotor contaminated with oil. 4. Brake pads worn out.	1. Adjust air pressure to 75 PSI. 2. Find and fix air leaks. 3. Clean brake rotor with automotive brake parts cleaner. 4. Replace brake pads.
Grinding noise when braking.	1. Brakes severely worn out.	1. Replace brake pads, have rotor turned (possibly replaced).

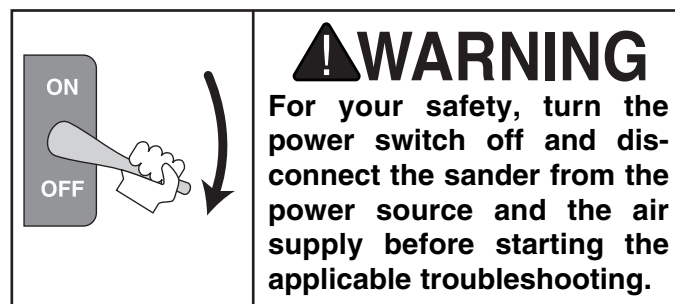

# Control Panel Component Locations (H2933/H2934/G0447/G0581)

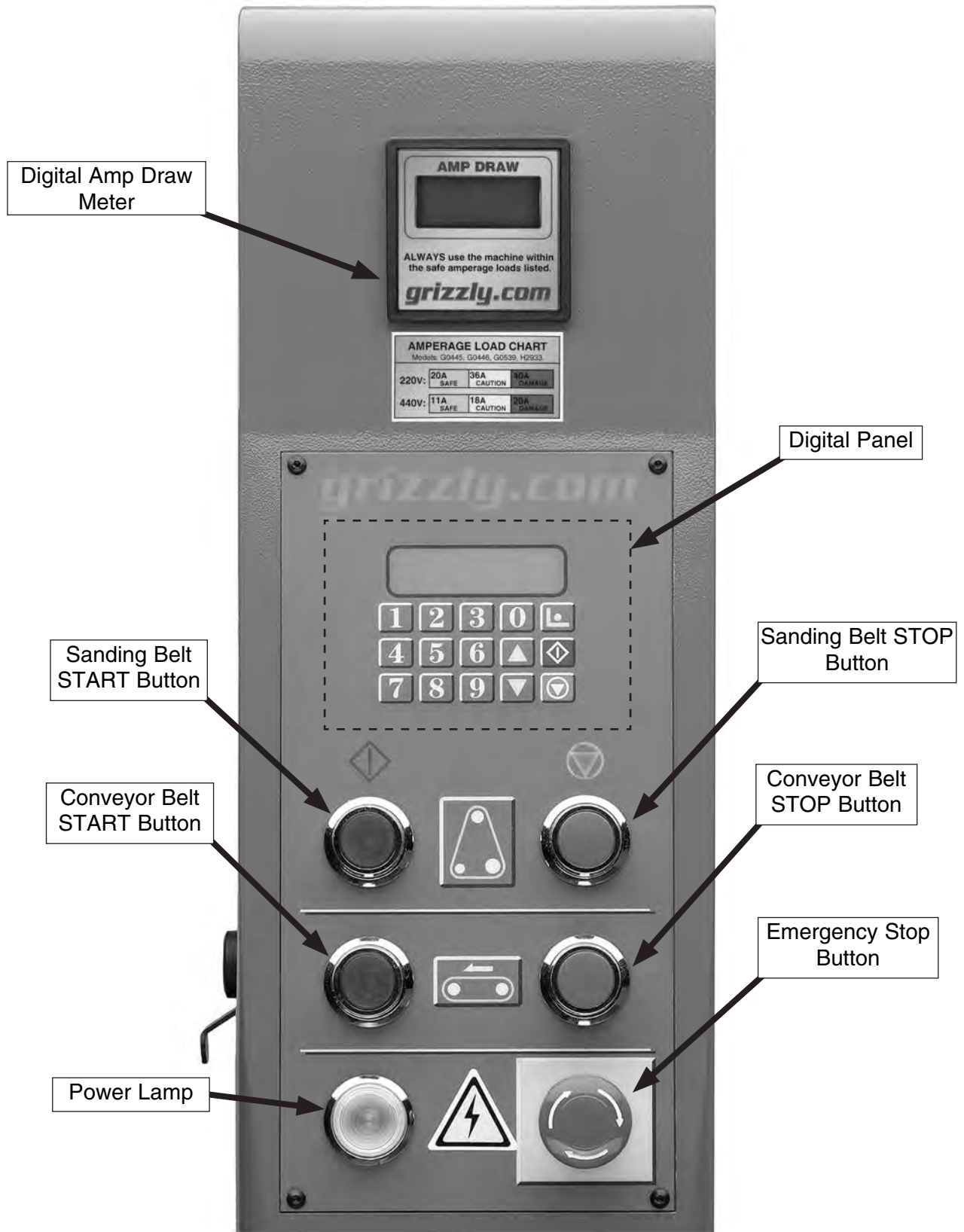

# Control Panel Electrical Diagram (H2933/H2934/G0447)

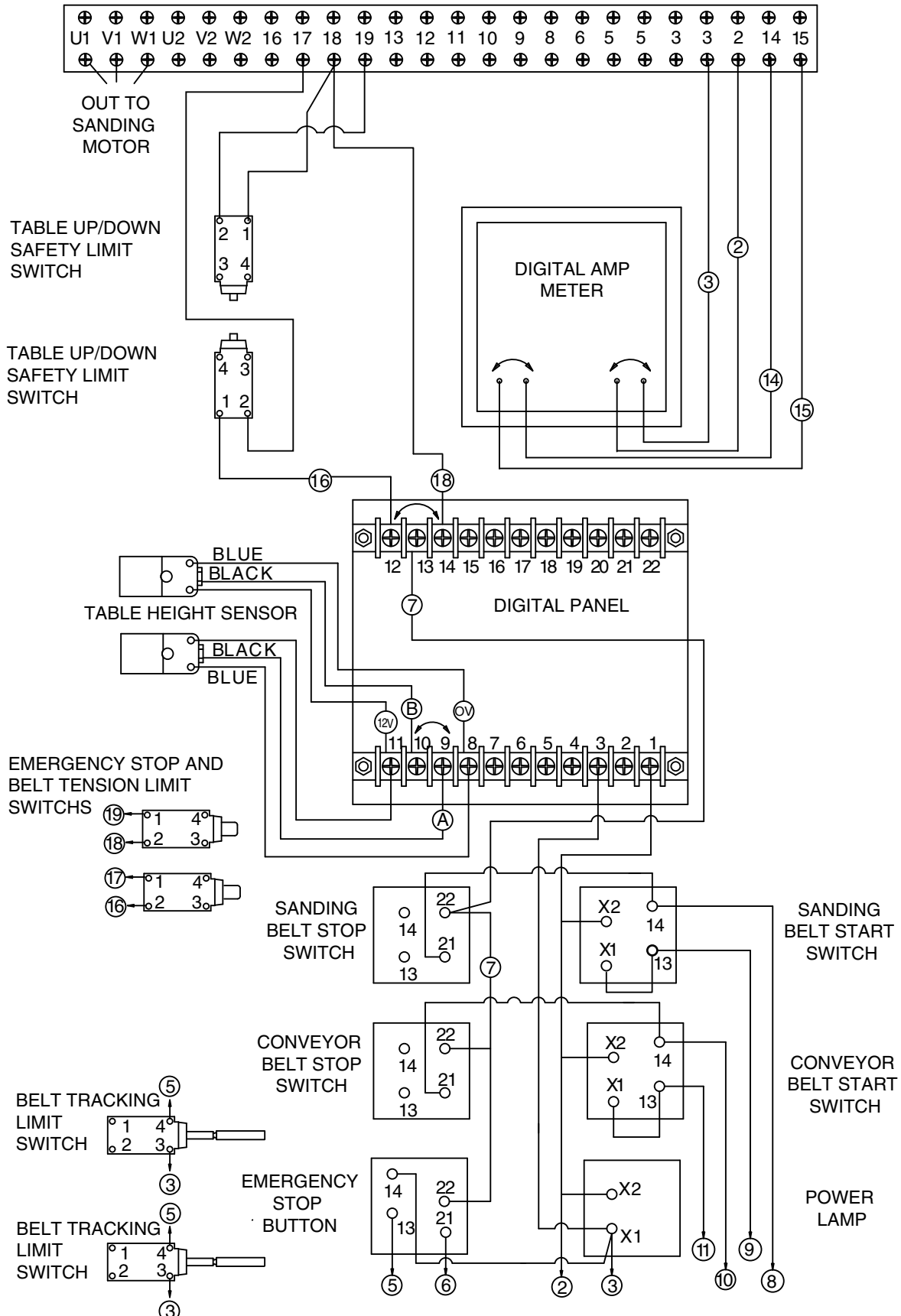

# Control Panel Electrical Diagram (G0581)

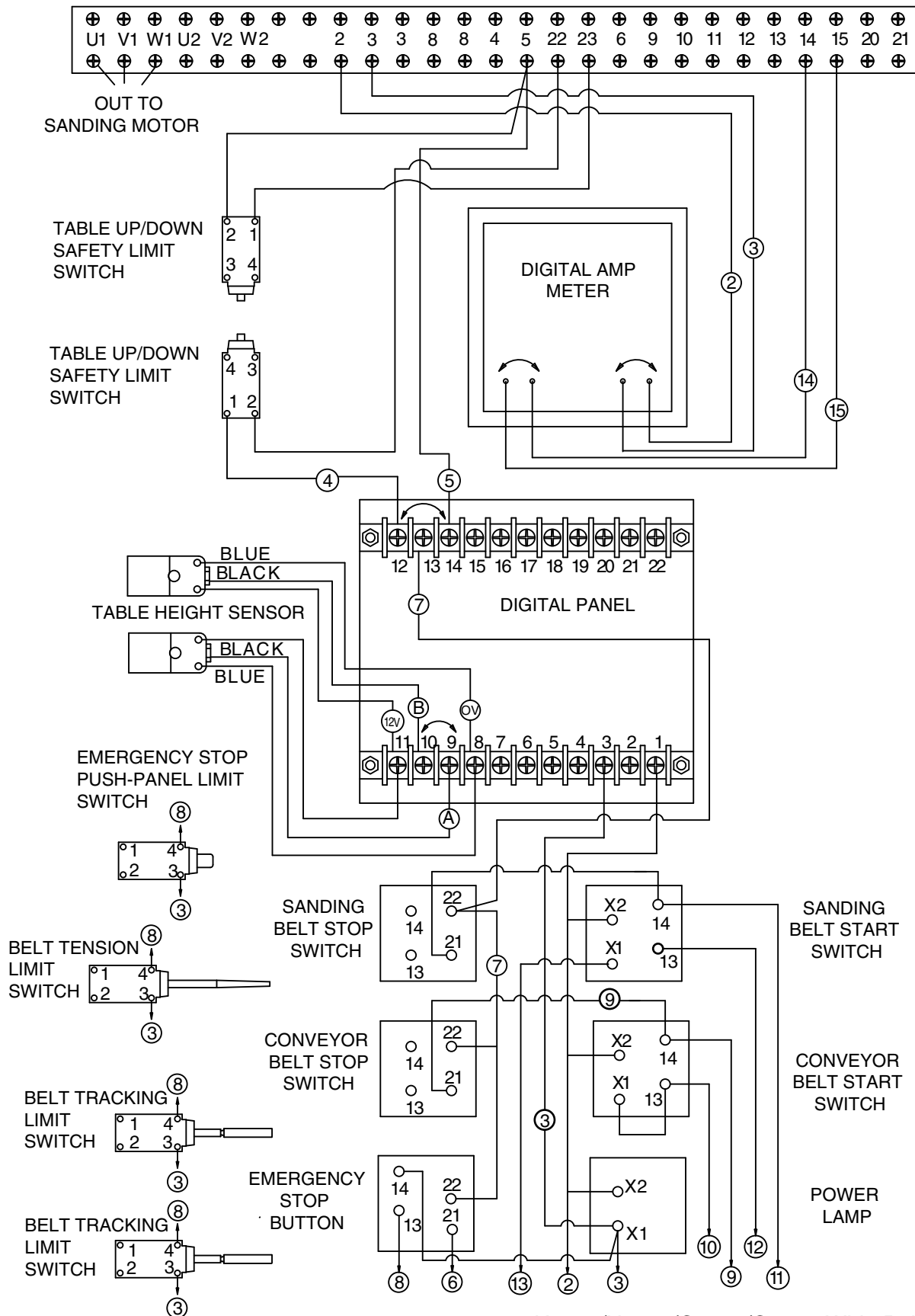

# Notes





# Wiring Box Electrical Diagram (H2933) 220V 3-PH

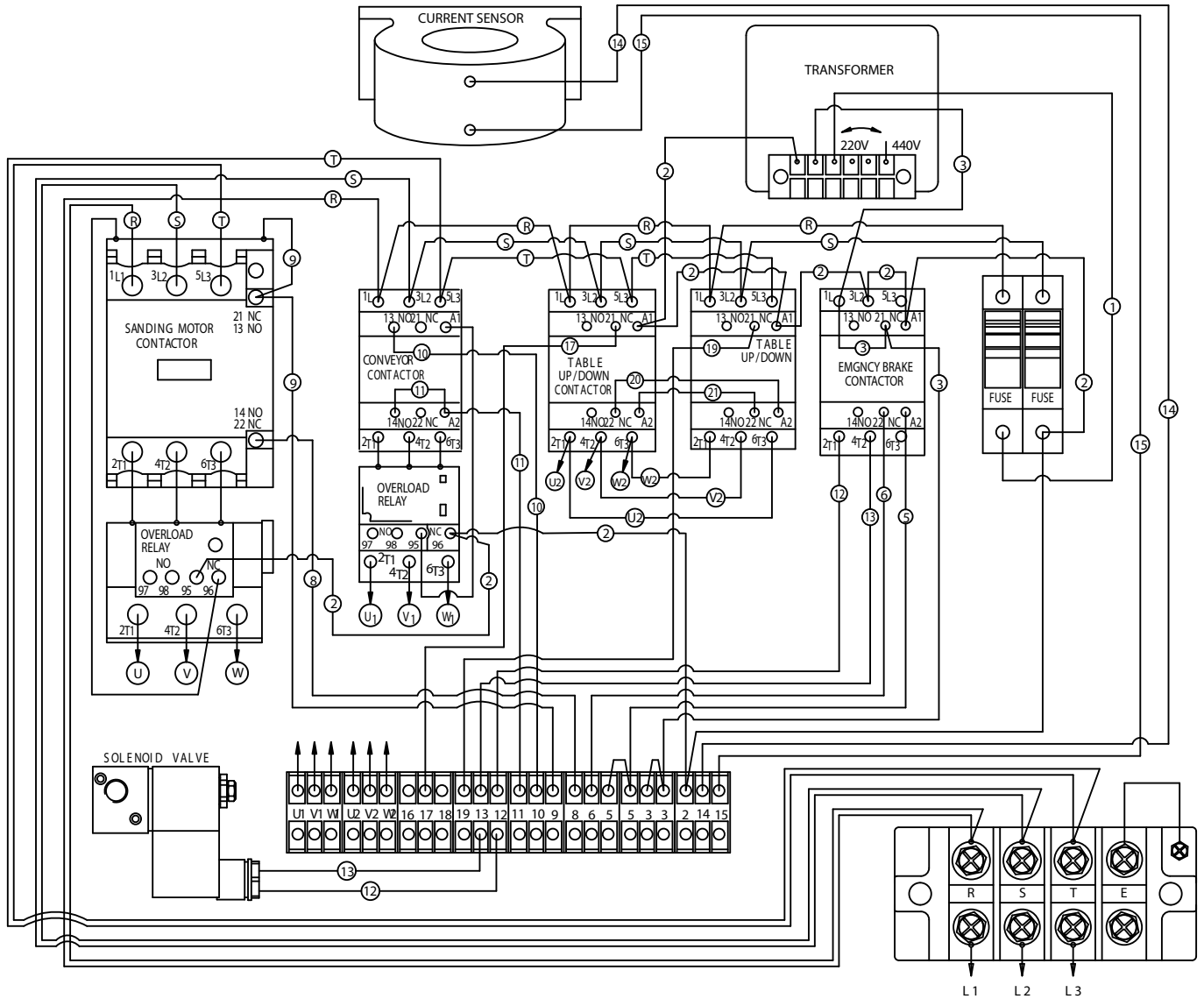

# Wiring Box Components (H2933)

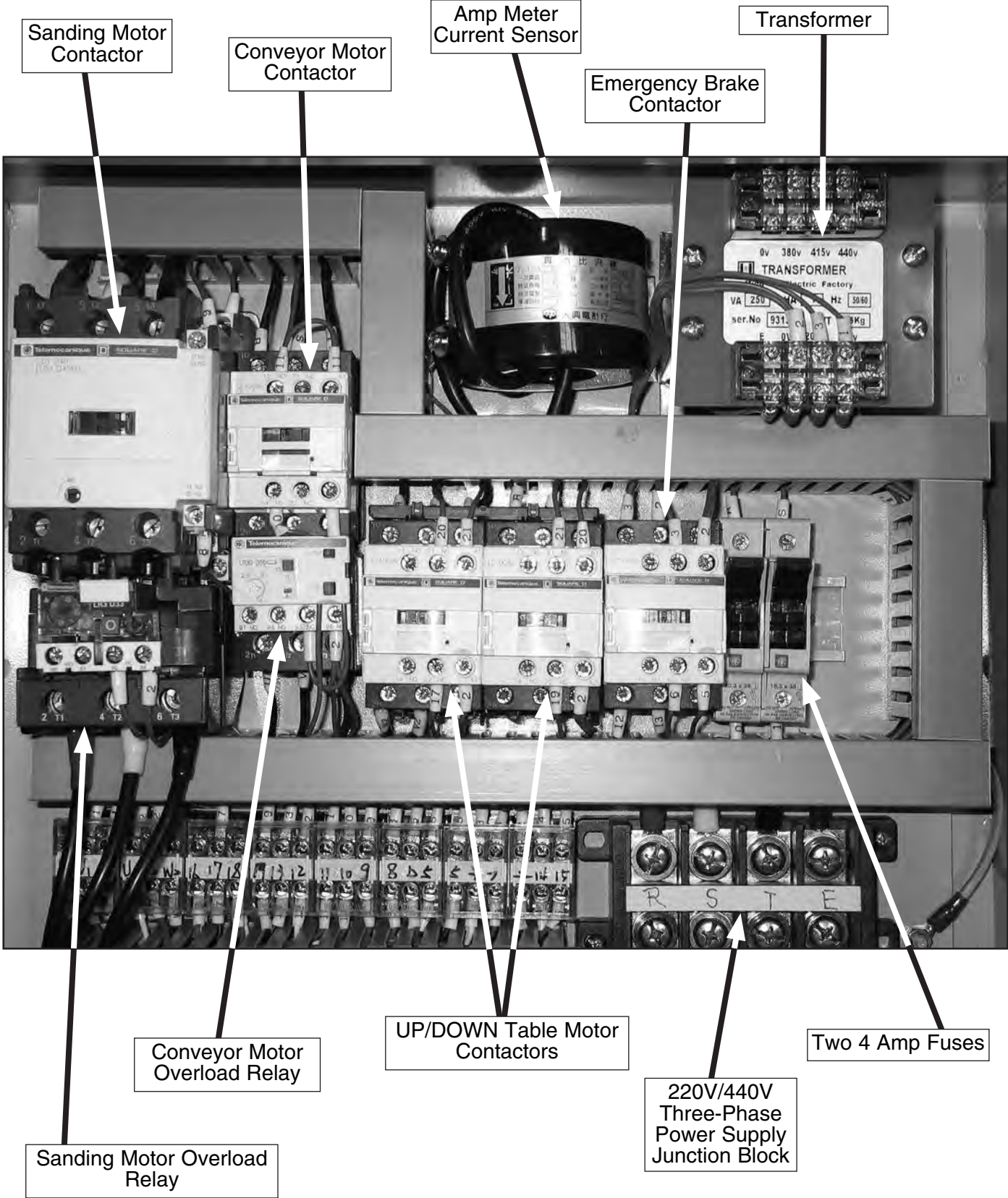

# Wiring Box Electrical Diagram (H2934/G0447) 220V 3-PH

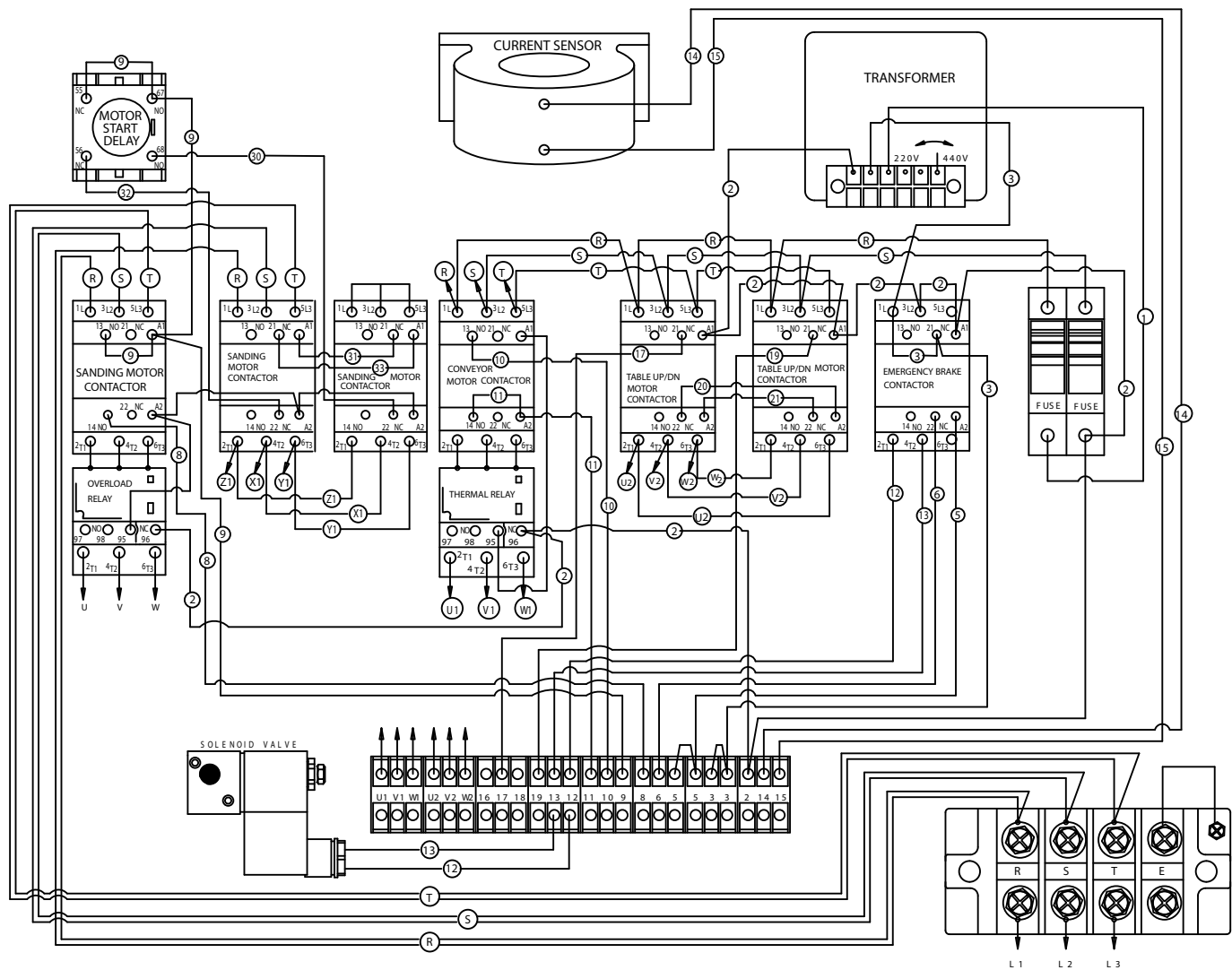

# Wiring Box Components (H2934/G0447)

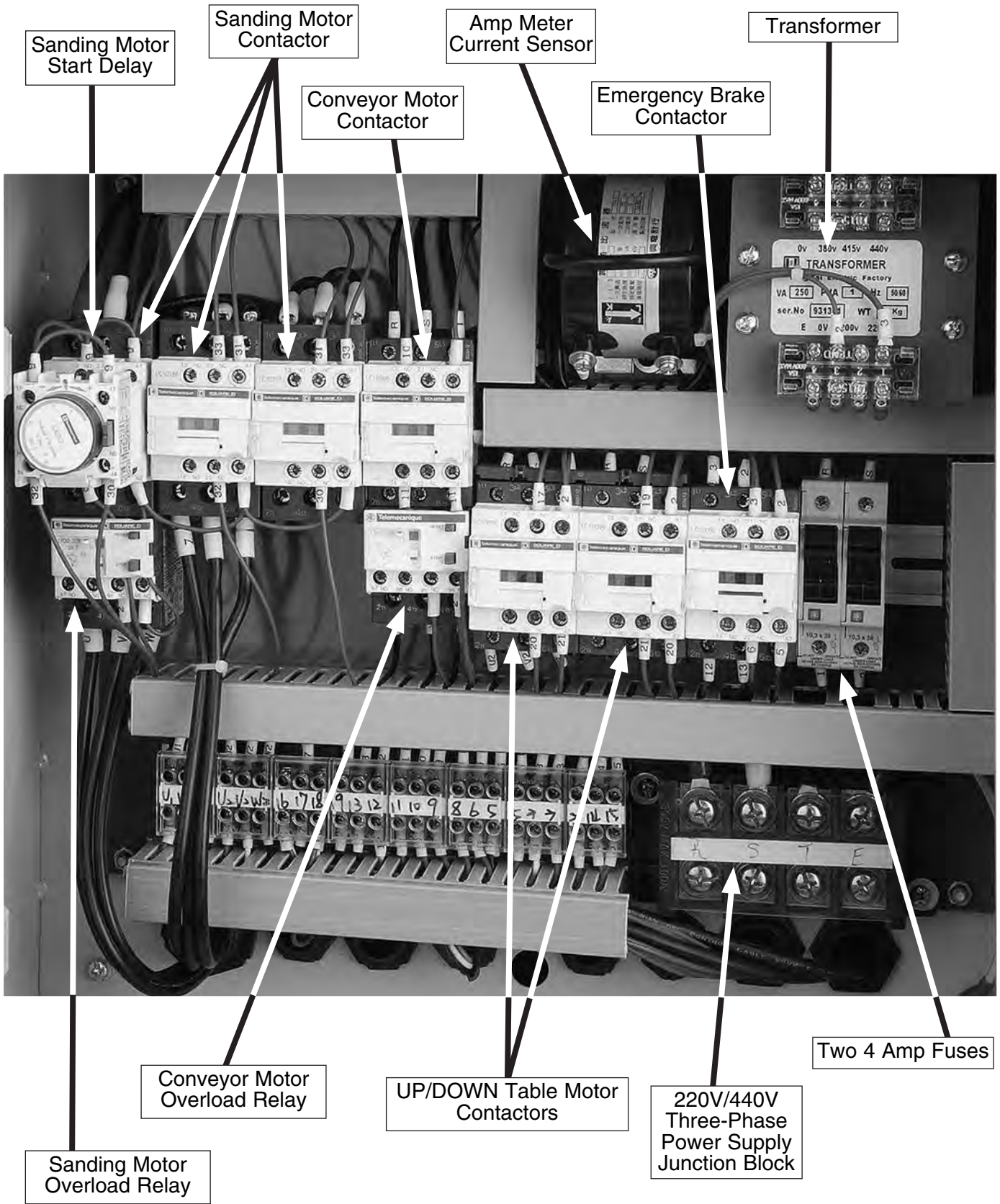



# Wiring Box Electrical Diagram (G0581) 220V 3-PH

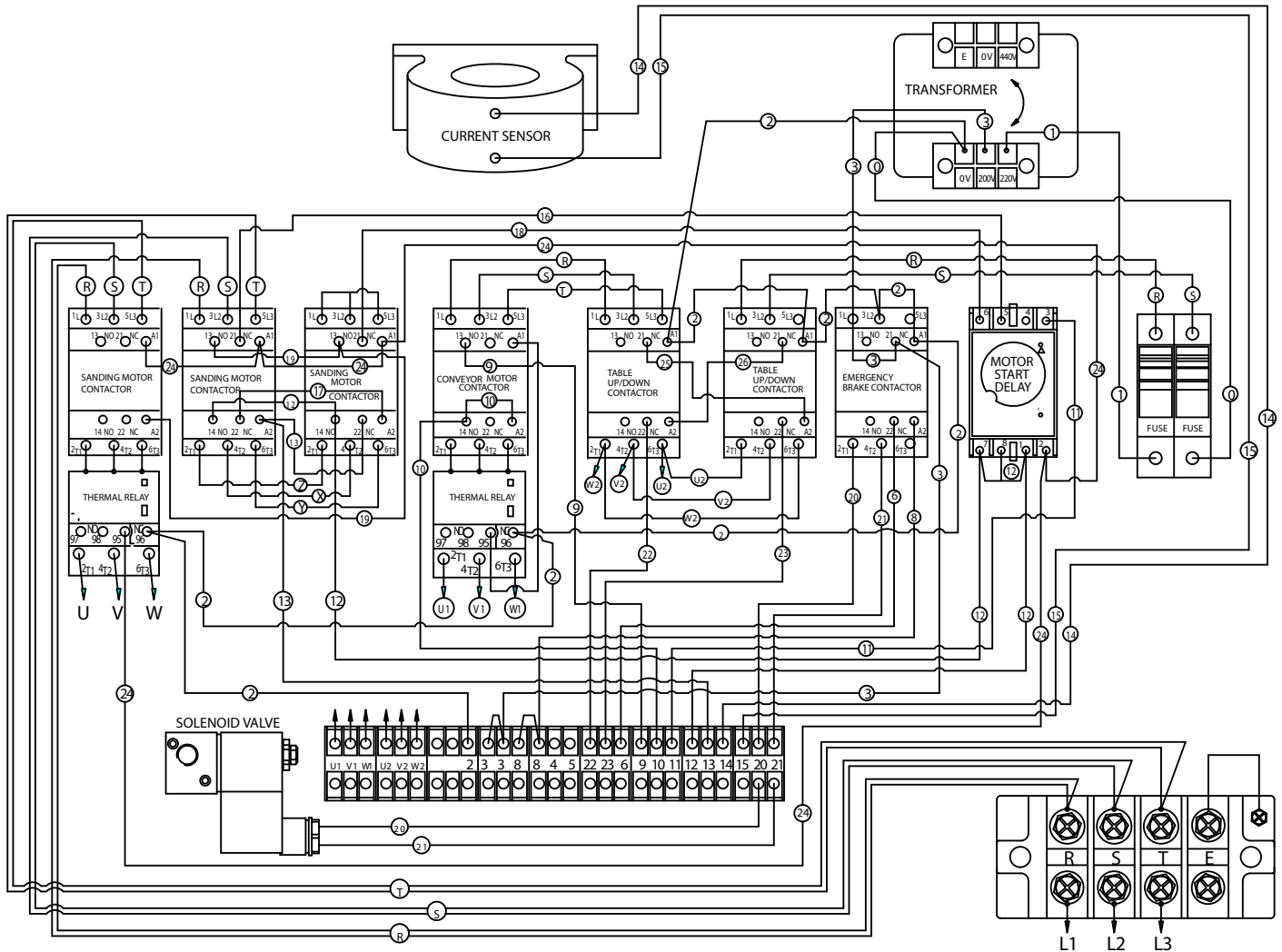

# Wiring Box Components (G0581)

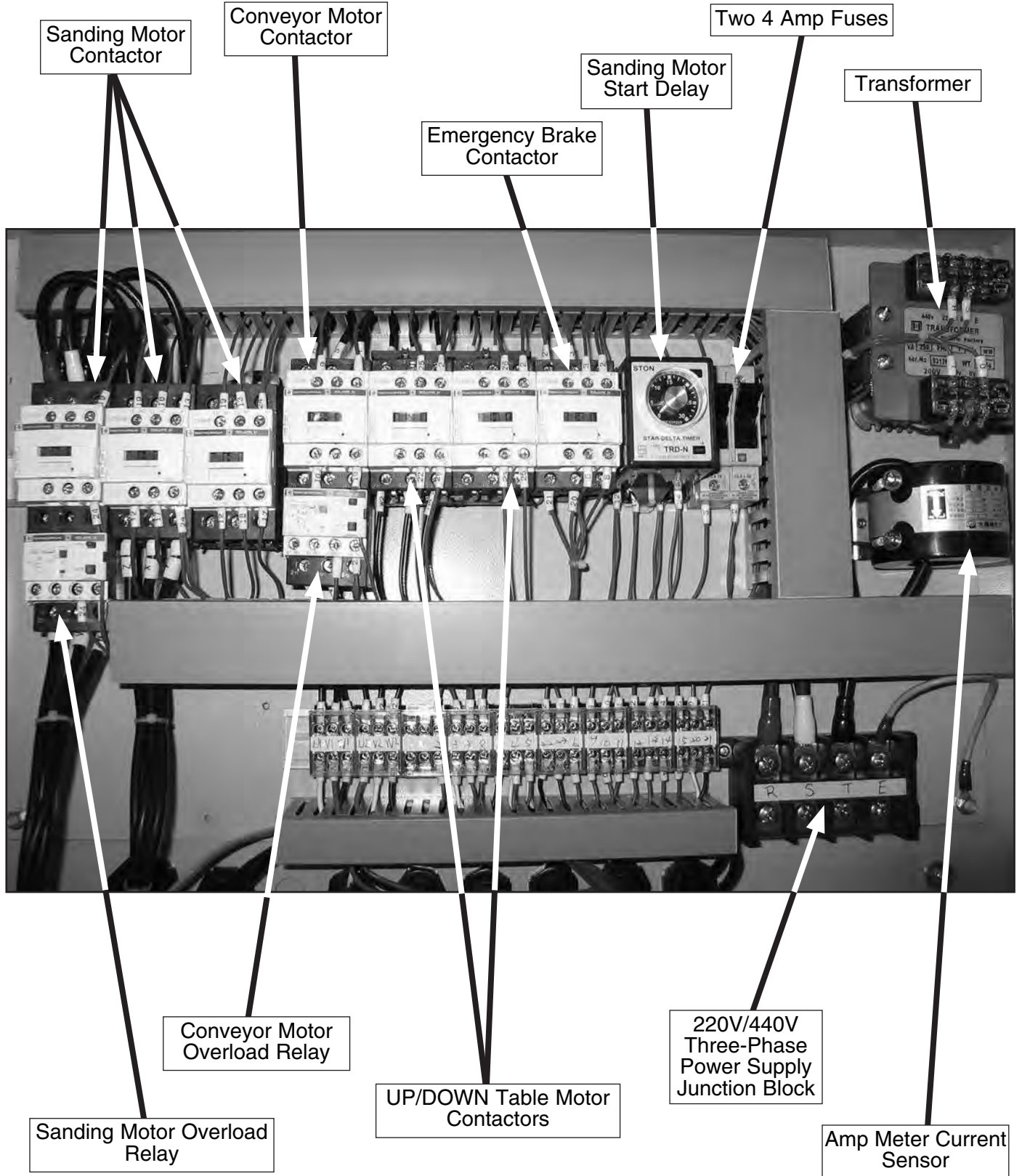



# General Electrical Diagram (H2933) 220V 3-PH

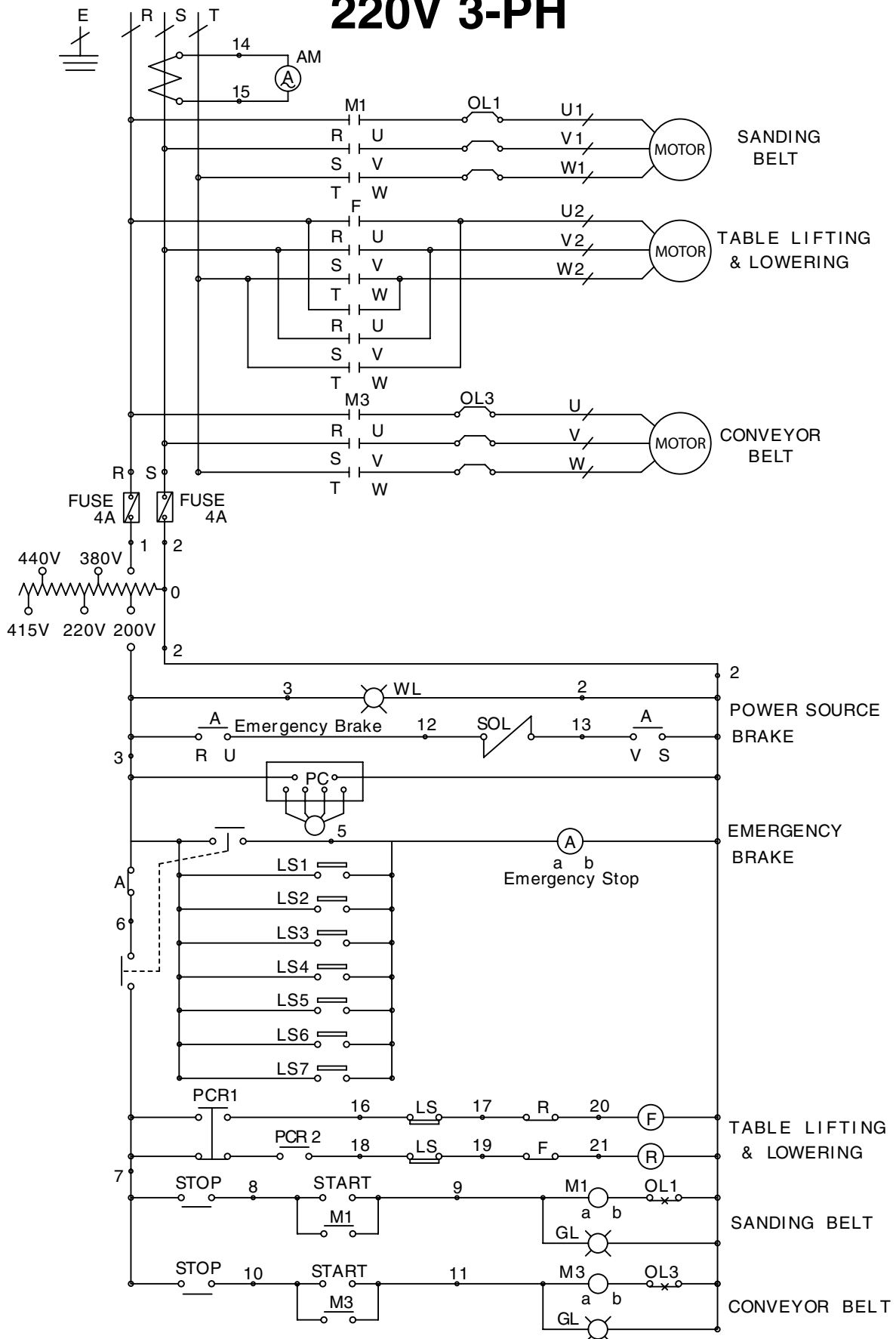

# General Electrical Diagram (H2934/G0447)

## 220V 3-PH

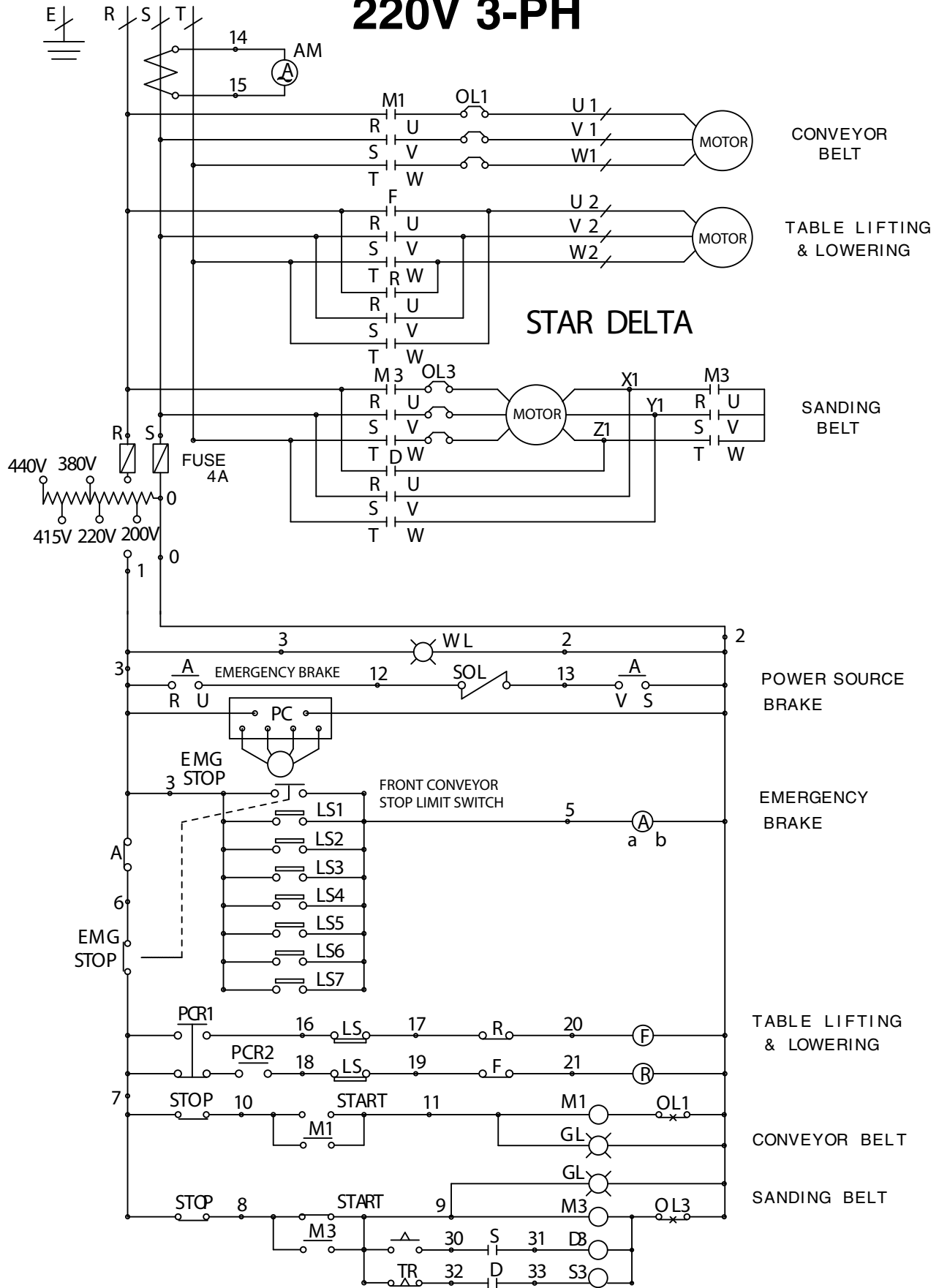

# General Electrical Diagram (G0581) 220V 3-PH

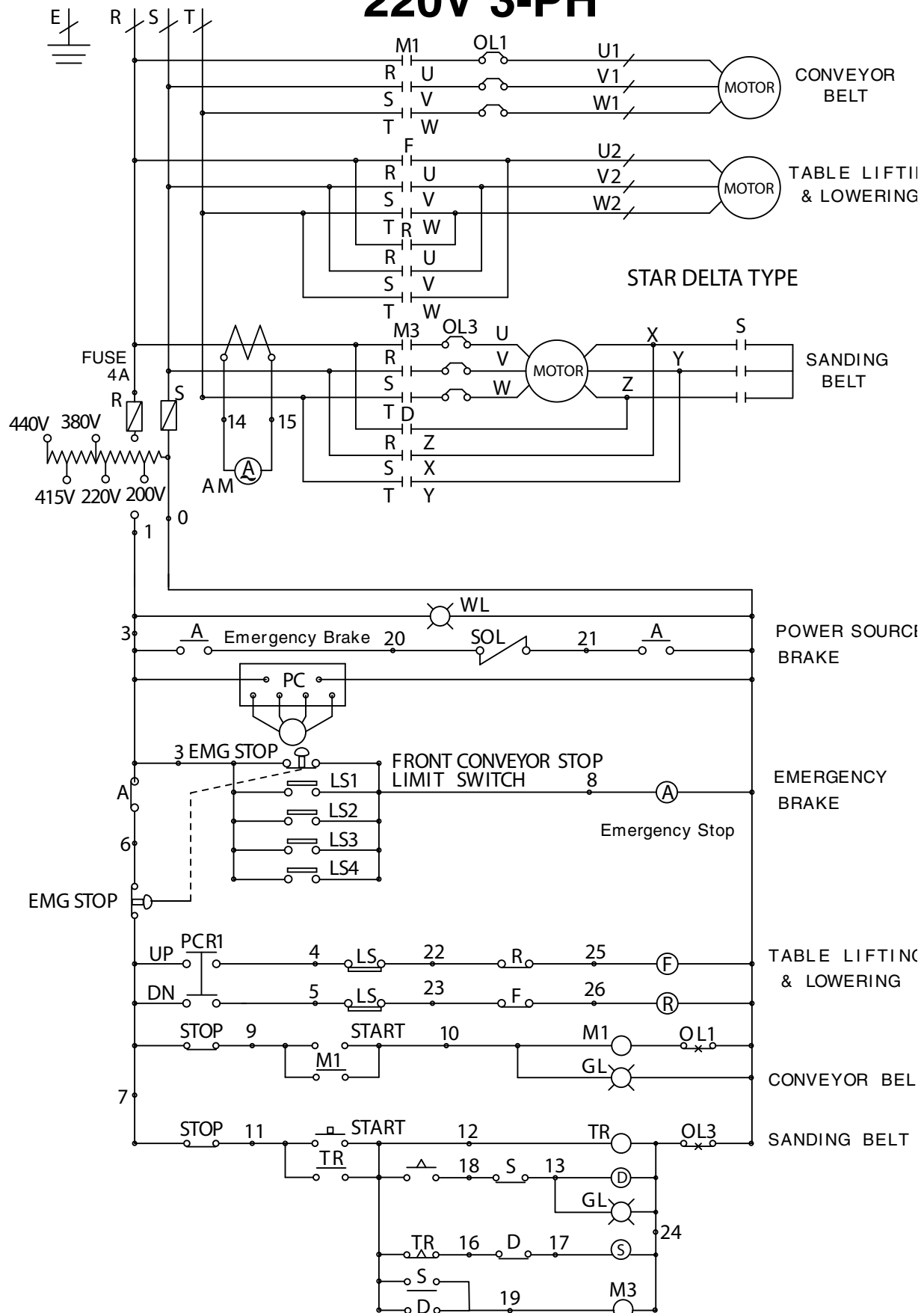

# Motor Wiring (H2933) 220V-440V 3-PH

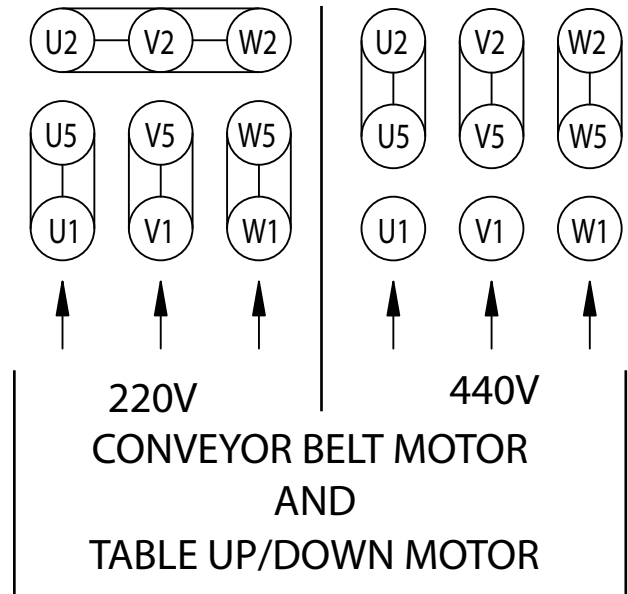
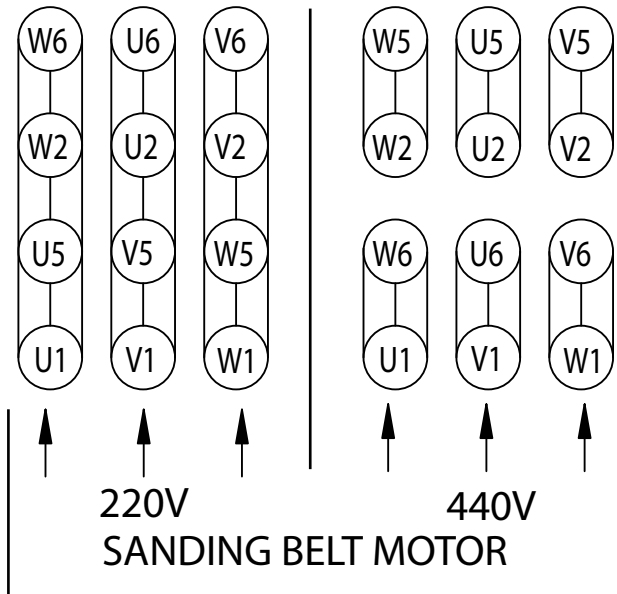

# Motor Wiring (H2934/G0447/G0581) 220V-440V 3-PH

(STAR DELTA)

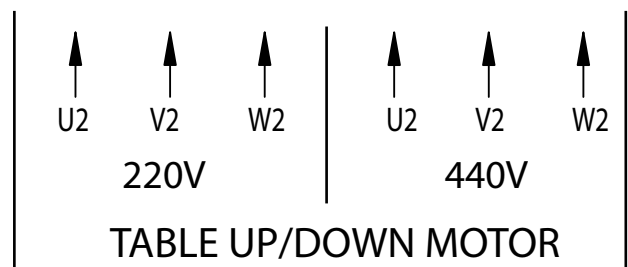
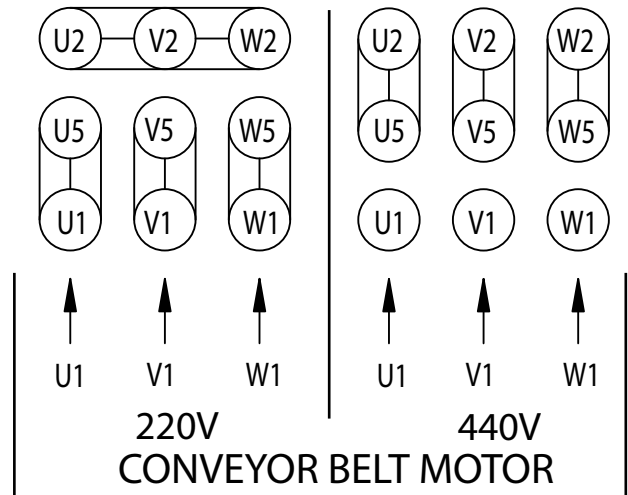
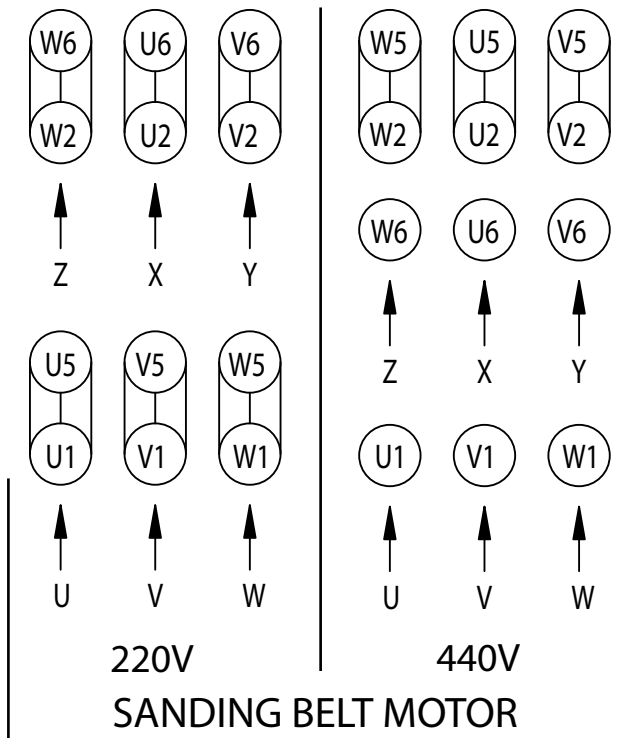

# Tool Box and Accessories Diagram

## 0000 Series Parts

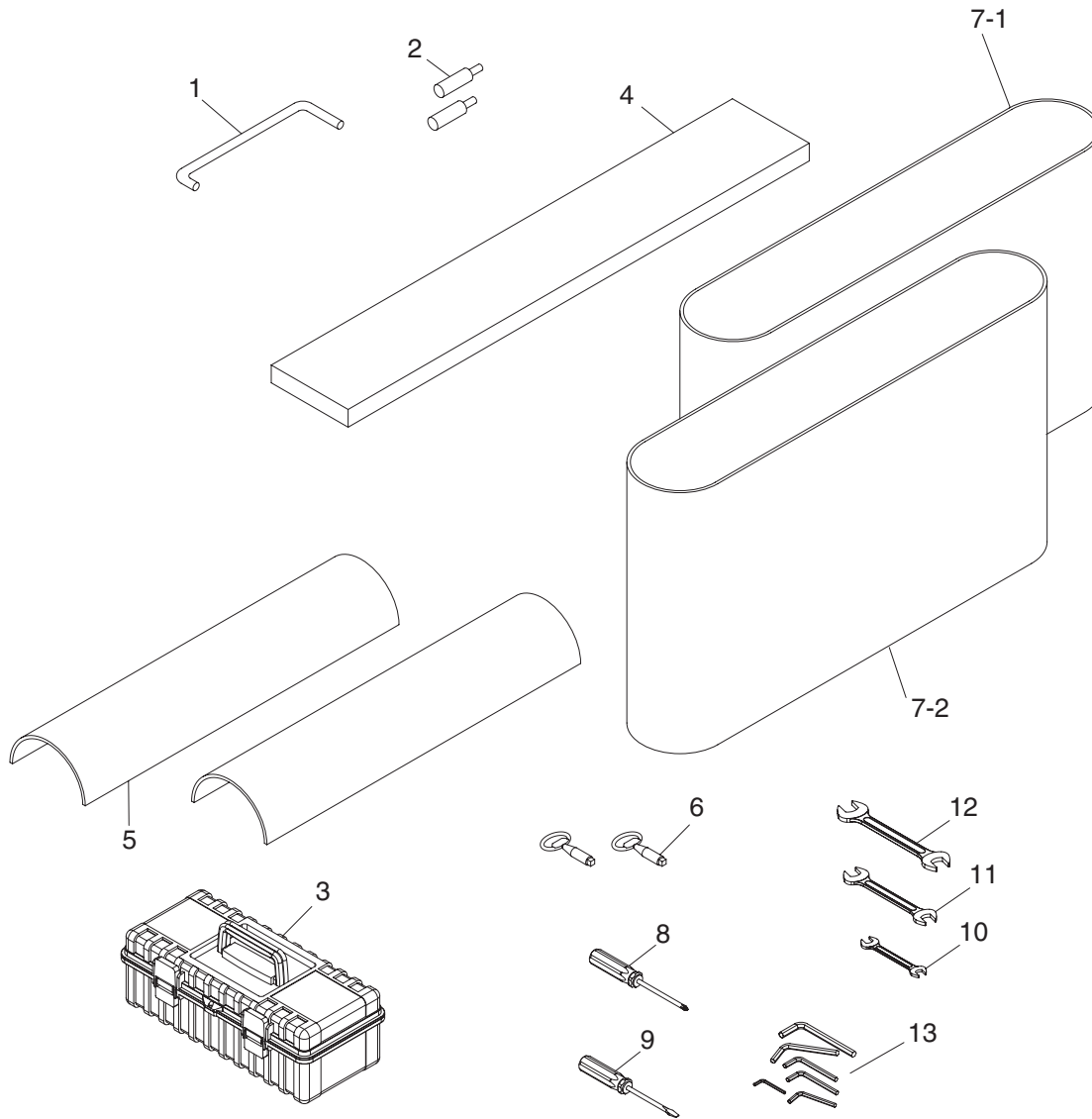

# Tool Box and Accessories Parts List

REF	PART #	DESCRIPTION
1	PH29330001	PLATEN REMOVAL TOOL
2	PH29330002	CERAMIC LIMIT SWITCH TIP
3	PH29330003	TOOL BOX
4	PH29330004	25" FELT PLATEN PAD (H2933)
4	PH2934004	37-3/4" PLATEN FELT (H2934/G0447)
4	P058100004	44" PLATEN FELT (G0581)
5	PH29330005	GRAPHITE 25" X 3.54" (H2933)
5	PH29340005	GRAPHITE 37-3/4" X 3.54" (H2934/G0447)
5	P05810005	GRAPHITE 44" X 3.54" (G0581)
6	PH29330006	DOOR KEY
7-1	PH29330007-1	SANDPAPER #100 (25" X 60") (H2933)
7-1	PH29340007-1	SANDPAPER #100 (37" X 60") (H2934)

REF	PART #	DESCRIPTION
7-1	P04470007-1	SANDPAPER #100 (37" X 75") (G0447)
7-1	P05810007-1	SANDPAPER #100 (43" X 60") (G0581)
7-2	PH29330007-2	SANDPAPER #180 (25" X 60") (H2933)
7-2	PH29340007-2	SANDPAPER #180 (37" X 60") (H2934)
7-2	P04470007-2	SANDPAPER #180 (37" X 75") (G0447)
7-2	P05810007-2	SANDPAPER #180 (43" X 60") (G0581)
8	PH29330008	#2 PHILLIPS SCREWDRIVER
9	PH29330009	SCREWDRIVER FLAT #2
10	PH29330010	WRENCH 8 X 10
11	PH29330011	WRENCH 12 X 14
12	PH29330012	WRENCH 17 X 19
13	PH29330013	HEX WRENCH SET





# Sanding Motor System Diagram

## 1000 Series Parts

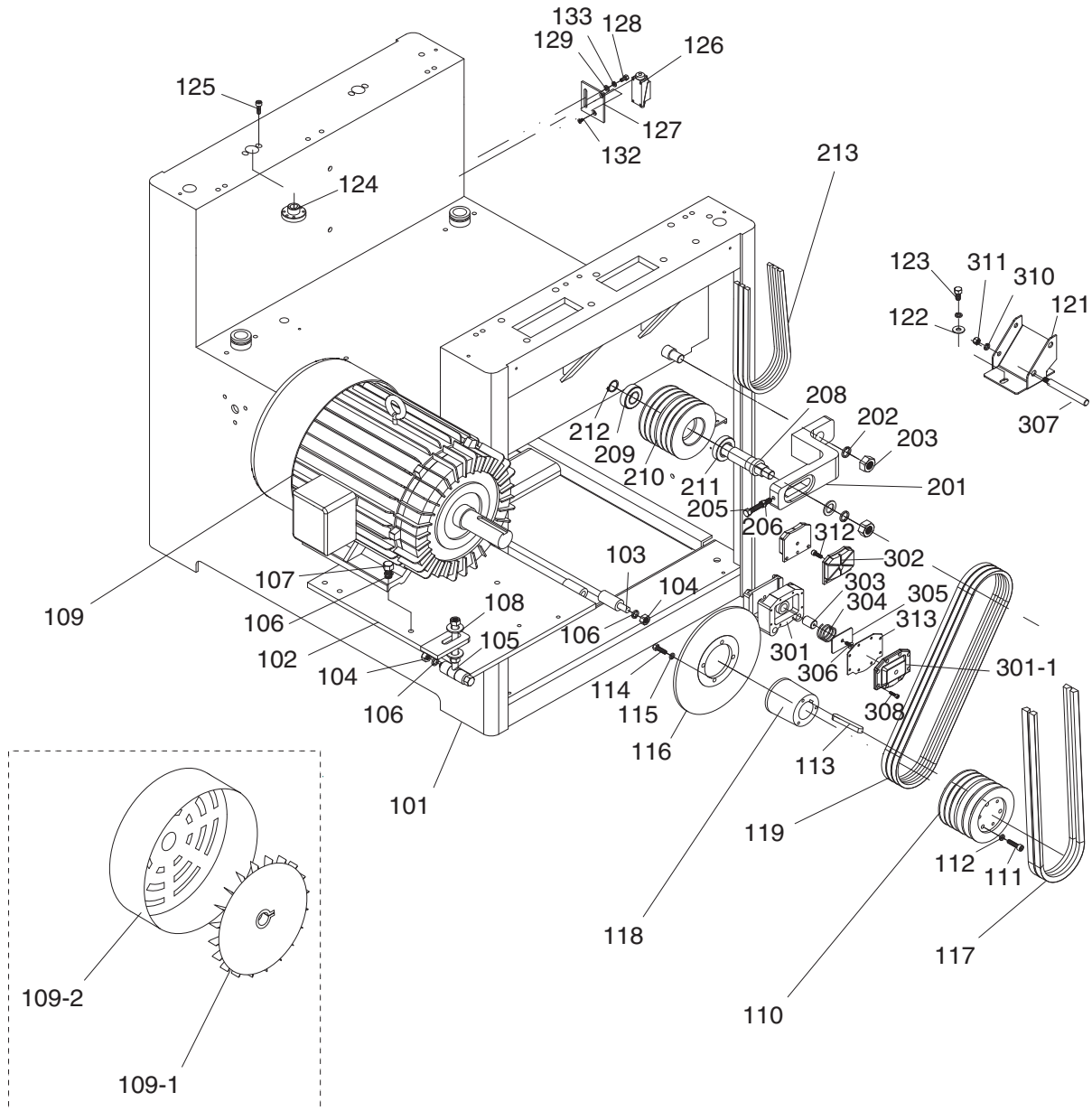

# Sanding Motor System Parts List

REF	PART #	DESCRIPTION
101	PH29331101	MACHINE FRAME (H2933)
101	PH29341101	MACHINE FRAME (H2934/G0447)
101	P05811101	MACHINE FRAME (G0581)
102	PH29331102	MOTOR BASE (H2933)
102	PH29341102	MOTOR BASE (H2934/G0447)
102	P05811102	MOTOR BASE (G0581)
103	PH29331103	MOTOR BASE HINGE (H2933)
103	PH29341103	MOTOR BASE HINGE (H2934/G0447)
103	P05811103	MOTOR BASE HINGE (G0581)
104	PH29331104	HEX NUT 1/2-12
105	PH29331105	MOTOR BASE ADJUSTMENT ROD
106	PH29331106	LOCK WASHER 1/2
107	PH29331107	HEX BOLT 1/2-12 X 1-1/2
108	PH29331108	FLAT WASHER 1/2
109	PH29331109	MOTOR 15HP 220V/440V 3PH (H2933)
109	PH29341109	MOTOR 20HP 220V/440V 3PH (H2934/G0447)
109	P05811109	MOTOR 25HP 220V/440V 3PH (G0581)
109-1	PH29331109-1	MOTOR FAN (H2933)
109-1	PH29341109-1	MOTOR FAN (H2934/G0447)
109-1	P05811109-1	MOTOR FAN (G0581)
109-2	PH29331109-2	MOTOR FAN COVER (H2933)
109-2	PH29341109-2	MOTOR FAN COVER (H2934/G0447)
109-2	P05811109-2	MOTOR FAN COVER (G0581)
110	PH29331110	PULLEY (H2933)
110	PH29341110	PULLEY (H2934/G0447)
110	P05811110	PULLEY (G0581)
111	PH29331111	CAP SCREW 5/16-18 X 1-1/4
112	PH29331112	LOCK WASHER 5/16
113	PH29331113	KEY 12 X 8 X105
114	PH29331114	HEX BOLT 5/16-18 X 1
115	PH29331115	LOCK WASHER 5/16
116	PH29331116	ROTOR
117	PH29331117	V-BELT B-76 5L760
118	PH29331118	PULLEY BUSHING (H2933)

REF	PART #	DESCRIPTION
118	PH29341118	PULLEY BUSHING (H2934/G0447)
118	P05811118	PULLEY BUSHING (G0581)
119	PH29331119	V-BELT A-50 4L500
121	PH29331121	BRAKE BRACKET
122	PH29331122	FLAT WASHER 3/8
123	PH29331123	HEX BOLT 3/8-16 X 3/4
124	PH29331124	FLAT HEAD NUT
125	PH29331125	CAP SCREW 1/4-20 X 3/4
126	PH29331126	LIMIT SWITCH
127	PH29331127	LIMIT SWITCH PLATE
128	PH29331128	HEX BOLT 1/4-20 X 1/2
129	PH29331129	FLAT WASHER 1/4
132	PH29331132	FLAT HD SCR M6-1 X 25
133	PH29331133	LOCK WASHER 1/4
201	PH29331201	IDLE WHEEL ADJ BRACKET
202	PH29331202	LOCK WASHER 3/4
203	PH29331203	HEX NUT 1/2-12
205	PH29331205	HEX BOLT 3/8-16 X 3-1/2
206	PH29331206	HEX NUT 3/8-16
208	PH29331208	IDLE WHEEL SHAFT
209	PH29331209	BALL BEARING 6305ZZ
210	PH29331210	PULLEY
211	PH29331211	BALL BEARING 6206ZZ
212	PH29331212	EXT RETAINING RING 25MM
213	PH29331213	V-BELT A-40 4L400
301	PH29331301	BRAKE BRACKET
301-1	PH29331301-1	BREAK BRACKET FRONT GUARD
302	PH29331302	BRAKE LINING SET
303	PH29331303	BRAKE ARBOR
304	PH29331304	BRAKE COMPRESSION SPRING
305	PH29331305	BRAKE INSIDE PIECE
306	PH29331306	FLAT HD SCR 1/4-20 X 5/8
307	PH29331307	BRAKE PIN
308	PH29331308	CAP SCREW 10-24 X 5/8
310	PH29331310	LOCK WASHER 3/8
311	PH29331311	HEX NUT 3/8-16
312	PH29331312	CAP SCREW 1/4-20 X 1/2
313	PH29331313	BRAKE GASKET



# Table Lift System Diagram

## 2000 Series Parts

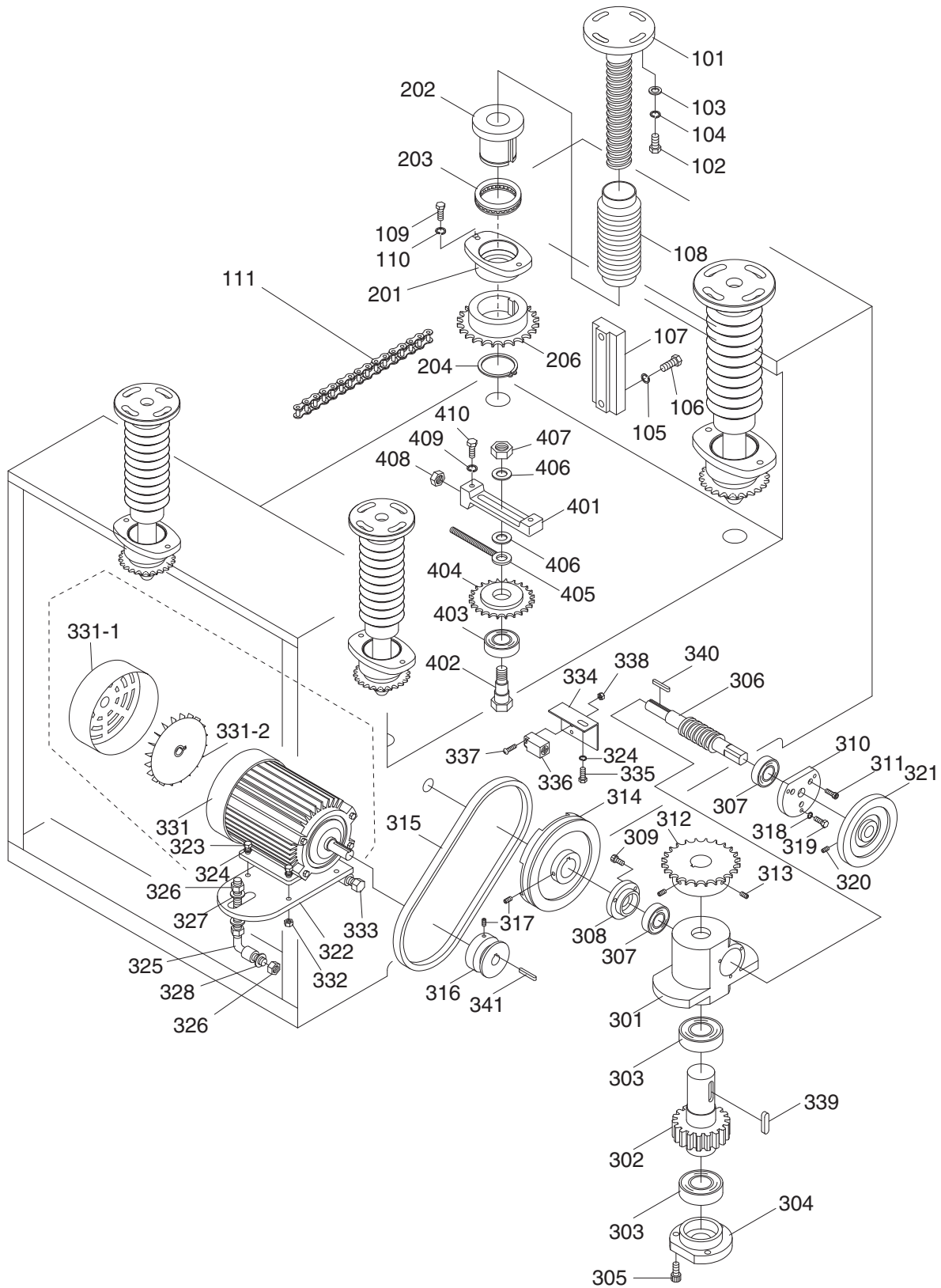

# Table Lift System Parts List

REF	PART #	DESCRIPTION
101	PH29332101	ELEVATION SCREW
102	PH29332102	HEX BOLT 5/16-18 X 1
103	PH29332103	FLAT WASHER 5/16
104	PH29332104	LOCK WASHER 5/16
105	PH29332105	LOCK WASHER 3/8
106	PH29332106	HEX BOLT 3/8-16 X 1
107	PH29332107	ELEVATION SLIDE
108	PH29332108	DUST BOOT
109	PH29332109	HEX BOLT 5/16-18 X 3/4
110	PH29332110	LOCK WASHER 5/16
111	PH29332111	CHAIN (H2933)
111	PH29342111	CHAIN (H2934/G0447)
111	P05812111	CHAIN (G0581)
201	PH29332201	NUT HOUSING
202	PH29332202	NUT
203	PH29332203	THRUST BEARING 51107
204	PH29332204	EXT RETAINING RING 35MM
206	PH29332206	SPROCKET WHEEL
301	PH29332301	ELEVATION GEAR BOX
302	PH29332302	WORM GEAR
303	PH29332303	BALL BEARING 6005ZZ
304	PH29332304	BEARING CAP
305	PH29332305	CAP SCREW 1/4-20 X 3/4
306	PH29332306	WORM SHAFT
307	PH29332307	BALL BEARING 6002ZZ
308	PH29332308	BEARING CAP
309	PH29332309	CAP SCREW 10-24 x 3/4
310	PH29332310	BEARING CAP
311	PH29332311	CAP SCREW 1/4-20 X 5/8
312	PH29332312	SPROCKET WHEEL
313	PH29332313	SET SCREW 1/4-20 X 1/2
314	PH29332314	PULLEY
315	PH29332315	V-BELT A-36 4L360
316	PH29332316	PULLEY
317	PH29332317	SET SCREW 1/4-20 X 1/2

REF	PART #	DESCRIPTION
318	PH29332318	LOCK WASHER 5/16
319	PH29332319	HEX BOLT 5/16-18 X 3/4
320	PH29332320	SET SCREW 1/4-20 X 1/2
321	PH29332321	HAND WHEEL
322	PH29332322	MOTOR BASE
323	PH29332323	HEX BOLT 1/4-20 X 1
324	PH29332324	LOCK WASHER 1/4
325	PH29332325	ADJUSTMENT ROD
326	PH29332326	FLAT WASHER 1/2
327	PH29332327	HEX NUT 1/2-12
328	PH29332328	LOCK WASHER 1/2
331	PH29332331	MOTOR 1/4HP 220V/440V 3PH (ALL MODELS)
331-1	PH29332331-1	FAN COVER (ALL MODELS)
331-2	PH29332331-2	FAN (ALL MODELS)
332	PH29332332	HEX NUT 1/4-20
333	PH29332333	HEX BOLT 1/2-12 X 4-1/2
334	PH29332334	PROXIMITY SWITCH PLATE
335	PH29332335	HEX BOLT 1/4-20 X 1/2
336	PH29332336	PROXIMITY SWITCH
337	PH29332337	SPECIAL SCREW M3-.5 X 40
338	PH29332338	HEX NUT M3-.5
339	PH29332339	KEY 5/16 X 5/16 X 3/4
340	PH29332340	KEY 4 X 4 X 20
341	PH29332341	KEY 4 X 4 X 16
401	PH29332401	SPROCKET WHEEL ADJUSTOR
402	PH29332402	SPROCKET WHEEL SHAFT
403	PH29332403	BALL BEARING 6003ZZ
404	PH29332404	ADJUSTMENT SPROCKET
405	PH29332405	ADJUSTMENT ROD
406	PH29332406	FLAT WASHER 3/8
407	PH29332407	HEX NUT 3/8-16
408	PH29332408	HEX NUT 5/16-18
409	PH29332409	LOCK WASHER 5/16
410	PH29332410	HEX BOLT 5/16-18 X 3/4



# Conveyor System Diagram

## 3000 Series Parts

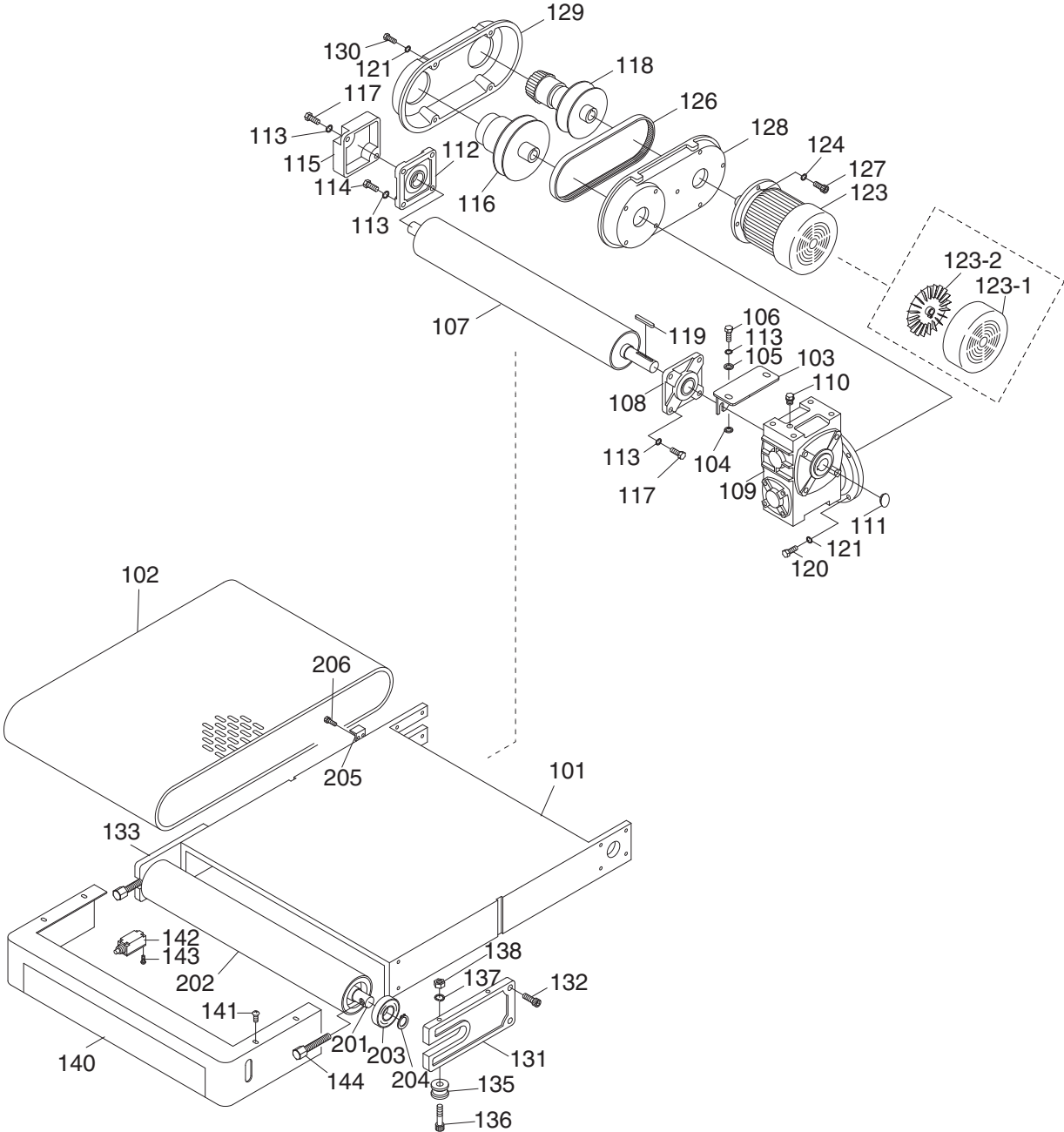

# Conveyor System Parts List

REF	PART #	DESCRIPTION
101	PH29333101	CONVEYOR TABLE (H2933)
101	PH29343101	CONVEYOR TABLE (H2934/G0447)
101	P05813101	CONVEYOR TABLE (G0581)
102	PH29333102	CONVEYOR BELT (H2933)
102	PH29343102	CONVEYOR BELT (H2934/G0447)
102	P05813102	CONVEYOR BELT (G0581)
103	PH29333103	REDUCER FIX PLATE
104	PH29333104	CUSHION
105	PH29333105	LOCK WASHER 3/8
106	PH29333106	HEX BOLT 3/8-16 X 1
107	PH29333107	OUTFEED ROLLER (H2933)
107	PH29343107	OUTFEED ROLLER (H2934/G0447)
107	P05813107	OUTFEED ROLLER (G0581)
108	PH29333108	BEARING UCF206
109	PH29333109	GEARBOX
110	PH29333110	BREATHER
111	PH29333111	PLUG
112	PH29333112	BALL BEARING UCF205
113	PH29333113	LOCK WASHER 3/8
114	PH29333114	HEX BOLT 3/8-16 X 1-1/4
115	PH29333115	BEARING CAP
116	PH29333116	DRIVEN PULLEY
117	PH29333117	HEX BOLT 3/8-16 X 1-1/2
118	PH29333118	DRIVING PULLEY
119	PH29333119	KEY 7 X 7 X 55
120	PH29333120	HEX BOLT M8-1.25 X 25
121	PH29333121	LOCK WASHER 8MM
123	PH29333123	MOTOR 1HP 220V/440V 3PH (H2933, H2934, G0447)
123	P05813123	MOTOR 2HP 220V/440V 3PH (G0581)
123-1	PH29333123-1	MOTOR FAN COVER (H2933, H2934, G0447)

REF	PART #	DESCRIPTION
123-1	P05813123-1	MOTOR FAN COVER (G0581)
123-2	PH29333123-2	MOTOR FAN (H2933, H2934, G0447)
123-2	P05813123-2	MOTOR FAN (G0581)
124	PH29333124	LOCK WASHER 5/8
126	PH29333126	TIMING BELT 1422V-290
127	PH29333127	CAP SCREW M10-1.5 X 25
128	PH29333128	BASE PLATE
129	PH29333129	VARIABLE SPEED UNIT COVER
130	PH29333130	HEX BOLT M8-1.25 X 20
131	PH29333131	INFEED ROLLER BRACKET
132	PH29333132	CAP SCREW 10-24 x 3/4
133	PH29333133	INFEED ROLLER BRACKET
135	PH29333135	CONVEYOR POSITION WHEEL
136	PH29333136	CAP SCREW 5/16-18 X 2
137	PH29333137	LOCK WASHER 5/16
138	PH29333138	HEX NUT 5/16-18
140	PH29333140	EMGNKY BRAKE PUSH-PLATE (H2933)
140	PH29343140	EMGNKY BRAKE PUSH-PLATE (H2934/G0447)
140	P05813140	EMGNKY BRAKE PUSH-PLATE (G0581)
141	PH29333141	PHLP HD SCR 1/4-20 X 1/2
142	PH29333142	LIMIT SWITCH
143	PH29333143	PHLP HD SCR 10-24 x 1 1/2
144	PH29333144	HEX BOLT 1/2-12 X 3
201	PH29333201	INFEED ROLLER SHAFT
202	PH29333202	INFEED ROLLER (H2933)
202	PH29343202	INFEED ROLLER (H2934/G0447)
202	P05813202	INFEED ROLLER (G0581)
203	PH29333203	BALL BEARING 6206ZZ
204	PH29333204	EXT RETAINING RING 30MM
205	PH29333205	ELEVATION LIMITER
206	PH29333206	CAP SCREW 1/4-20 X 1-1/2





# Feed, Drum, and Pressure Roller Diagram

## 4000 Series Parts

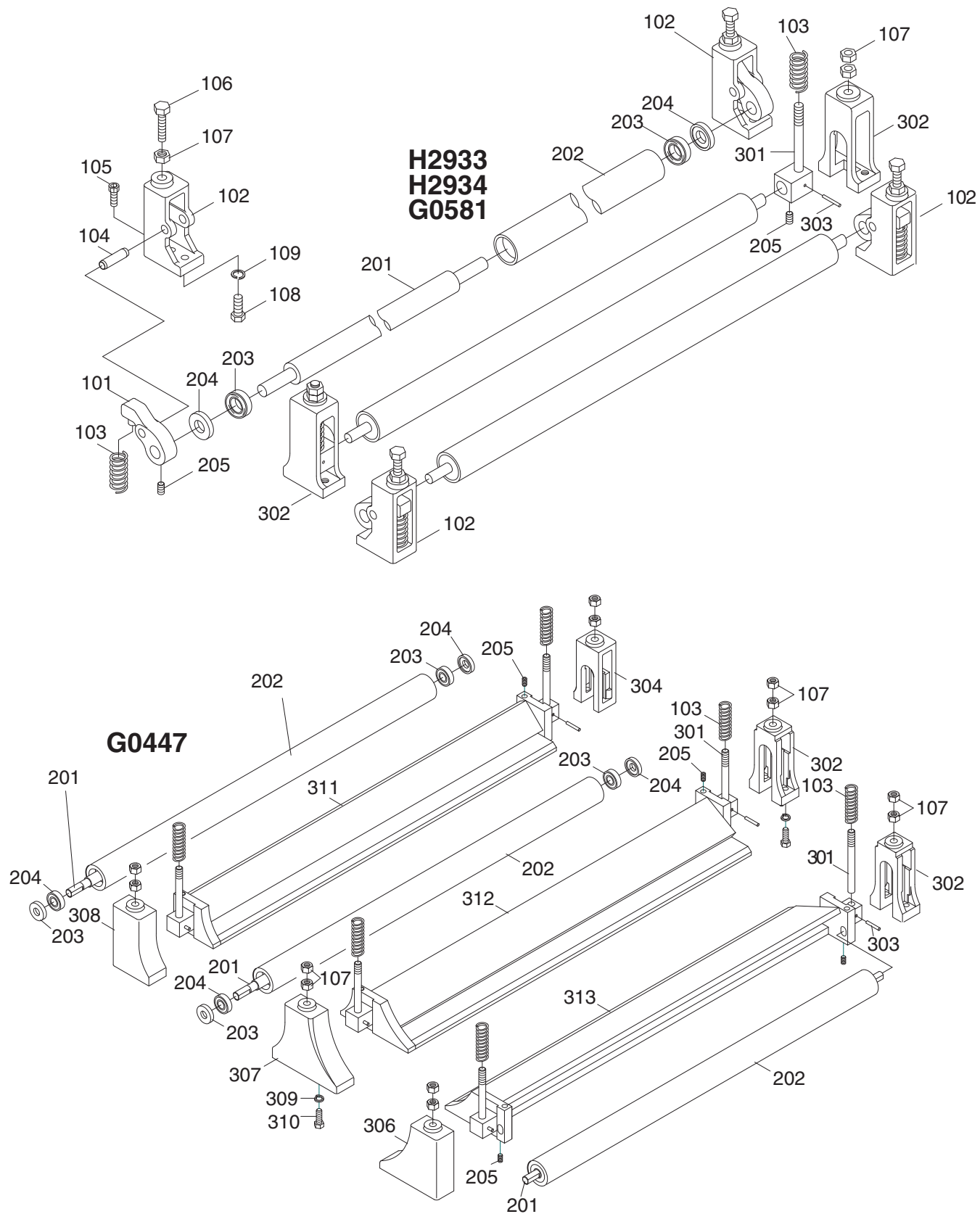

# Feed, Drum, and Pressure Roller Parts List

REF	PART #	DESCRIPTION
101	PH29334101	PISTON SLIDERAIL
102	PH29334102	PISTON BRACKET OUTER (H2933/H2934/G0581)
103	PH29334103	COMPRESSION SPRING
104	PH29334104	ROD 10 X 35
105	PH29334105	SET SCREW 1/4-20 X 1/2
106	PH29334106	HEX BOLT 5/16-18 X 1-1/2
107	PH29334107	HEX NUT 5/16-18
108	PH29334108	HEX BOLT 5/16-18 X 1-1/4
109	PH29334109	LOCK WASHER 5/16
201	PH29334201	PISTON ROLLER SHAFT (H2933)
201	PH29344201	PISTON ROLLER SHAFT (H2934/G0447)
201	P05814201	PISTON ROLLER SHAFT (G0581)
202	PH29334202	PISTON ROLLER (H2933)
202	PH29344202	PISTON ROLLER (H2934/G0447)
202	P05814202	PISTON ROLLER (G0581)
203	PH29334203	BALL BEARING 6003ZZ

REF	PART #	DESCRIPTION
204	PH29334204	SHAFT BEARING COLLAR
205	PH29334205	SET SCREW 1/4-20 X 1/2
301	PH29334301	GUIDE STUD (H2933/H2934/G0581)
301	P04474301	GUIDE STUD (G0447)
302	PH29334302	PISTON BRACKET MIDDLE
303	PH29334303	ROLL PIN 3 X 27
304	P04474304	RR PISTON BRACKET (G0447)
306	P04474306	LF PISTON BRACKET (G0447)
307	P04474307	L MIDDLE PISTON BRACKET (G0447)
308	P04474308	LR PISTON BRACKET (G0447)
309	PH29334309	LOCK WASHER 5/16
310	PH29334310	HEX BOLT 5/16-18 X 1-1/4
311	P04474311	REAR DEFLECTOR (G0447)
312	P04474312	MIDDLE DEFLECTOR (G0447)
313	P04474313	FRONT DEFLECTOR (G0447)



# Sanding Drum and Platen Diagram

## 5000 Series Parts

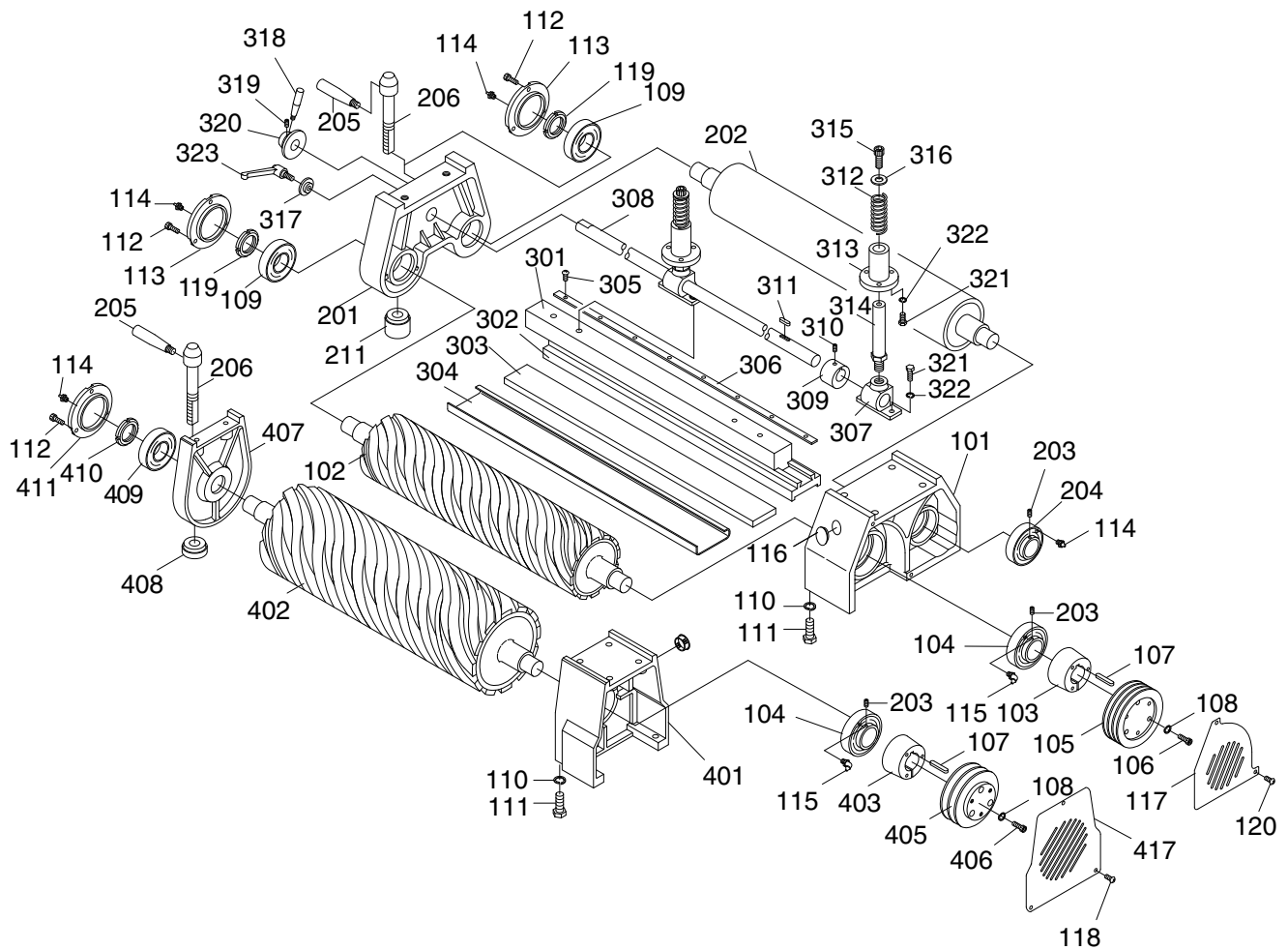

# Sanding Drum and Platen Parts List

REF	PART #	DESCRIPTION
101	PH29335101	BEARING HOUSING
102	PH29335102	RUBBER ROLLER (H2933)
102	PH29345102	RUBBER ROLLER (H2934/G0447)
102	P05815102	RUBBER ROLLER (G0581)
103	PH29335103	FASTENING TUBE
104	PH29335104	BEARING UCC206
105	PH29335105	PULLEY
106	PH29335106	CAP SCREW 5/16-18 X 1-1/4
107	PH29335107	KEY 5/16 X 5/16 X 1 3/16
108	PH29335108	LOCK WASHER 5/16
109	PH29335109	BALL BEARING 6205ZZ
110	PH29335110	LOCK WASHER 1/2
111	PH29335111	CAP SCREW 1/2-12 X 1-1/2
112	PH29335112	CAP SCREW 1/4-20 X 1/2
113	PH29335113	BEARING CAP
114	PH29335114	GREASE FITTING W/CAP
115	PH29335115	GREASE FITTING W/CAP
116	PH29335116	PLUG
117	PH29335117	PULLEY COVER
118	PH29335118	PHLP HD SCR 1/4-20 X 1/2
119	PH29335119	SPANNER NUT
120	PH29335120	PHLP HD SCR 1/4-20 X 3/8
201	PH29335201	BEARING HOUSING
202	PH29335202	STEEL ROLLER (H2933)
202	PH29345202	STEEL ROLLER (H2934/G0447)
202	P05815202	STEEL ROLLER (G0581)
203	PH29335203	SPECIAL SET SCREW M6-.75 X 6
204	PH29335204	BEARING UCC205
205	PH29335205	HANDLE
206	PH29335206	SPECIAL SCREW
211	PH29335211	BEARING BRACKET PAD (H2933)
301	PH29335301	25" GRAPHITE BRACKET MALE (H2933)
301	PH29345301	37-1/2" GRAPHITE BRACKET MALE (H2934/G0447)
301	P05815301	44" GRAPHITE BRACKET MALE (G0581)
302	PH29335302	25" GRAPHITE BRACKET FEMALE (H2933)
302	PH29345302	37-1/2" GRAPHITE BRACKET FEMALE (H2934/G0447)
302	P05815302	44" GRAPHITE BRACKET FEMALE (G0581)
303	PH29335303	25" FELT PLATEN PAD (H2933)
303	PH29345303	37-1/2" FELT PLATEN PAD (H2934/G0447)
303	P05815303	44" FELT PLATEN PAD (G0581)

REF	PART #	DESCRIPTION
304	PH29335304	GRAPHITE 25" x 3.54" (H2933)
304	PH29345304	GRAPHITE 37-3/4" x 3.54" (H2934/G0447)
304	P05815304	GRAPHITE 44" x 3.54" (G0581)
305	PH29335305	PHLP HD SCR 10-24 X 1/2
306	PH29335306	25" GRAPHITE PRESSURE PLATE (H2933)
306	PH29345306	37-1/2" GRAPHITE PRESSURE PLATE (H2934/G0447)
306	P05815306	44" GRAPHITE PRESSURE PLATE (G0581)
307	PH29335307	GRAPHITE BRACKET BASE
308	PH29335308	GRAPHITE BRACKET SHAFT (H2933)
308	PH29345308	GRAPHITE BRACKET SHAFT (H2934/G0447)
308	P05815308	GRAPHITE BRACKET SHAFT (G0581)
309	PH29335309	LOCK COLLAR
310	PH29335310	SET SCREW 1/4-20 X 3/8
311	PH29335311	KEY 1/4-20 X 25
312	PH29335312	COMPRESSION SPRING
313	PH29335313	HOUSING
314	PH29335314	GRAPHITE BRACKET SHAFT
315	PH29335315	CAP SCREW 3/8-16 X 3/4
316	PH29335316	FLAT WASHER 3/8
317	PH29335317	FLAT WASHER 3/8
318	PH29335318	HANDLE
319	PH29335319	SET SCREW 5/16-18 X 1/2
320	PH29335320	ADJUSTMENT RING
321	PH29335321	HEX BOLT 5/16-18 X 1
322	PH29335322	FLAT WASHER 5/16
323	PH29335323	HANDLE
401	PH29335401	BEARING HOUSING
402	PH29335402	RUBBER ROLLER (H2933)
402	PH29345402	RUBBER ROLLER (H2934/G0447)
402	P05815402	RUBBER ROLLER (G0581)
403	PH29335403	FASTENING TUBE
405	PH29335405	PULLEY
406	PH29335406	CAP SCREW 5/16-18 X 1-1/4
407	PH29335407	BEARING HOUSING
408	PH29335408	BEARING BRACKET PAD
409	PH29335409	BALL BEARING 6206ZZ
410	PH29335410	SPANNER CAP
411	PH29335411	BEARING CAP
417	PH29335417	PULLEY COVER





# Upper Roller System Parts List

REF	PART #	DESCRIPTION
101	PH29336101	SQUARE FRAME REAR (H2933)
101	PH29346101	SQUARE FRAME REAR (H2934)
101	P04476101	SQUARE FRAME REAR (G0447)
101	P05816101	SQUARE FRAME REAR (G0581)
101-1	PH29336101-1	SQUARE FRAME FRONT (H2933)
101-1	PH29346101-1	SQUARE FRAME FRONT (H2934)
101-1	P04476101-1	SQUARE FRAME FRONT (G0447)
101-1	P05816101-1	SQUARE FRAME FRONT (G0581)
103	PH29336103	FRAME SEAL RIGHT (H2933)
103	PH29346103	FRAME SEAL RIGHT (H2934)
103	P04476103	FRAME SEAL RIGHT (G0447)
103	P05816103	FRAME SEAL RIGHT (G0581)
103-1	PH29336103-1	FRAME SEAL FRONT (H2933)
103-1	PH29346103-1	FRAME SEAL FRONT (H2934)
103-1	P04476103-1	FRAME SEAL FRONT (G0447)
103-1	P05816103-1	FRAME SEAL FRONT (G0581)
104	PH29336104	FRAME SEAL LEFT (H2933)
104	PH29346104	FRAME SEAL LEFT (H2934)
104	P04476104	FRAME SEAL LEFT (G0447)
104	P05816104	FRAME SEAL LEFT (G0581)
104-1	PH29336104-1	FRAME SEAL FRNT LFT (H2933)
104-1	PH29346104-1	FRAME SEAL FRNT LFT (H2934)
104-1	P04476104-1	FRAME SEAL FRNT LFT (G0447)
104-1	P05816104-1	FRAME SEAL FRNT LFT (G0581)
105	PH29336105	FLAT HD SCR 1/4-20 X 1/2
106	PH29336106	LOCK WASHER 3/8
107	PH29336107	HEX BOLT 3/8-16 X 1
108	PH29336108	LOCK WASHER 1/2
109	PH29336109	HEX BOLT 1/2-12 X 1
110	PH29336110	PHLP HD SCR 1/4-20 X 1/2
111	PH29336111	CAP SCREW 5/16-18 X 3/4
112	PH29336112	HEX BOLT 5/16-18 X 1
113	PH29336113	AIR CYLINDER
115	PH29336115	LIMIT SWITCH W/CERAMIC TIP
115-1	PH29336115-1	CERAMIC TIP
116	PH29336116	LIMIT SWITCH W/PLASTIC TIP
116-1	PH29336116-1	PLASTIC TIP
116-2	PH29336116-2	LIMIT SWITCH POST
117	PH29336117	LIMIT SWITCH HOLDER
118	PH29336118	AIR SENSOR NOZZLE FEMALE
119	PH29336119	AIR FORK
120	PH29336120	AIR SENSOR NOZZLE MALE
121	PH29336121	THROTTLE VALVE
122	PH29336122	THROTTLE VALVE BASE
123	PH29336123	PLATE
124	PH29336124	HOUSING ASSEMBLY
125	PH29336125	OIL CAP
126	PH29336126	ALUMINUM PLATE

REF	PART #	DESCRIPTION
127	PH29336127	PHLP HD SCR M4-.7 X 12
128	PH29336128	SHUTDOWN BRACKET
129	PH29336129	HEX NUT 3/8-24
130	PH29336130	FLAT WASHER 5/16
131	PH29336131	LOCK WASHER 5/16
132	PH29336132	HEX BOLT 5/16-18 X 1/2
133	PH29336133	PHLP HD SCR 10-24 X 3/4
134	PH29336134	HEX NUT 10-24
135	PH29336135	CONNECTOR OF OIL CAP
136	PH29336136	SHAFT OF OIL CAP
137	P05816137	BRACKET (G0581)
138	P05816138	BRACKET (G0581)
139	PH29336139	CAP SCREW 5/16-18 X 1-1/2
140	PH29336140	CAP SCREW 1/2-12 X 1-1/2
141	PH29336141	LOCK WASHER 1/2
142	PH29336142	HEX BOLT 1/2-12 X 1
201	PH29336201	BRACKET (H2933, H2934, G0447)
201	P05816201	BRACKET (G0581)
202	PH29336202	UPPER ROLLER (H2933)
202	PH29346202	UPPER ROLLER (H2934/G0447)
202	P05816202	UPPER ROLLER (G0581)
203	PH29336203	UPPER ROLLER BRACKET
204	PH29336204	BEARING UCC205
205	PH29336205	SET SCREW M6-1 X 6
206	PH29336206	CAP SCREW 10-24 X 3/4
207	PH29336207	LOCK WASHER 3/8
208	PH29336208	GREASE FITTING W/DUST CAP
301	PH29336301	KNOB (H2933, H2934, G0447)
301	P05816301	KNOB (G0581)
302	PH29336302	ECCENTRIC ROD
303	PH29336303	CAP SCREW 1/2-12 X 3-1/2
304	PH29336304	FLAT WASHER 1/2
305	PH29336305	ECCENTRIC
306	PH29336306	CLEVIS ASSEMBLY
307	PH29336307	EXT RETAINING RING 15MM
308	PH29336308	HEX NUT M10-1.5 (LH)
309	PH29336309	SHAFT OF AIR CYLINDER
310	PH29336310	HEX NUT 1/2-12
311	PH29336311	BOTTOM COVER
312	PH29336312	COMPRESSION SPRING
313	PH29336313	ALUMINUM PLATE
314	PH29336314	FLAT HD SCR M6-1 X 12
315	PH29336315	PLATE
316	PH29336316	TOP COVER
317	PH29336317	HEX NUT 10-24
318	PH29336318	PHLP HD SCR 10-24 X 3/4
319	PH29336319	AIR CYLINDER BASE
320	PH29336320	ECCENTRIC SHAFT FRAME



# Cabinet Assembly Diagram

## 7000 Series Parts

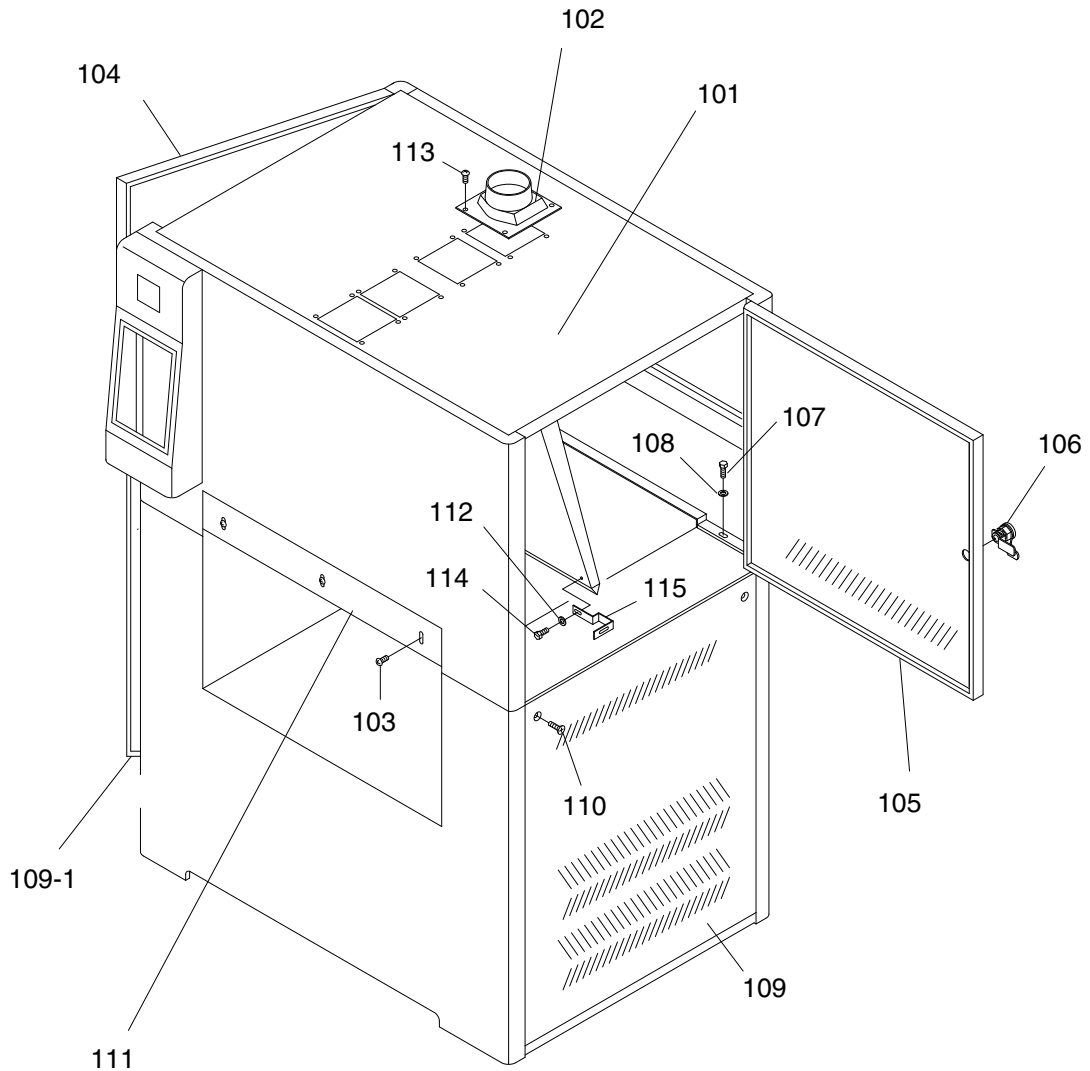



# Cabinet Assembly Parts List

REF	PART #	DESCRIPTION
101	PH29337101	UPPER FRAME COVER (H2933)
101	PH29347101	UPPER FRAME COVER (H2934)
101	P04477101	UPPER FRAME COVER (G0447)
101	P05817101	UPPER FRAME COVER (G0581)
102	PH29337102	DUST PORT 4"
103	PH29337103	PHLP HD SCR M6-1 X 12
104	PH29337104	LEFT ACCESS PANEL (H2933)
104	PH29347104	LEFT ACCESS PANEL (H2934)
104	P04477104	LEFT ACCESS PANEL (G0447)
104	P05817104	LEFT ACCESS PANEL (G0581)
105	PH29337105	RIGHT ACCESS PANEL (H2933)
105	PH29347105	RIGHT ACCESS PANEL (H2934)
105	P04477105	RIGHT ACCESS PANEL (G0447)
105	P05817105	RIGHT ACCESS PANEL (G0581)
106	PH29337106	DOOR LOCK
107	PH29337107	HEX BOLT 5/16-18 X 3/4
108	PH29337108	FLAT WASHER 5/16
109	PH29337109	RIGHT DOOR, LOWER FRAME (H2933)
109	PH29347109	RIGHT DOOR, LOWER FRAME (H2934)
109	P04477109	RIGHT DOOR, LOWER FRAME (G0447)

REF	PART #	DESCRIPTION
109	P05817109	RIGHT DOOR, LOWER FRAME (G0581)
109-1	PH29337109-1	LEFT DOOR, LOWER FRAME (H2933)
109-1	PH29347109-1	LEFT DOOR, LOWER FRAME (H2934)
109-1	P04477109-1	LEFT DOOR, LOWER FRAME (G0447)
109-1	P05817109-1	LEFT DOOR, LOWER FRAME (G0581)
110	PH29337110	FLAT HD SCR 1/4-20 X 1/2
111	PH29337111	FRONT PROTECTION PLATE (H2933)
111	PH29347111	FRONT PROTECTION PLATE (H2934)
111	P04477111	FRONT PROTECTION PLATE (G0447)
111	P05817111	FRONT PROTECTION PLATE (G0581)
112	PH29337112	FLAT WASHER 1/4
113	PH29337113	PHLP HD SCR M6-1 X 12
114	PH29337114	HEX BOLT 1/4-20 X 3/4
115	PH29337115	STANDOFF BRACKET



# Main Electrical Panel and Controls Diagram

## 8000 Series Parts

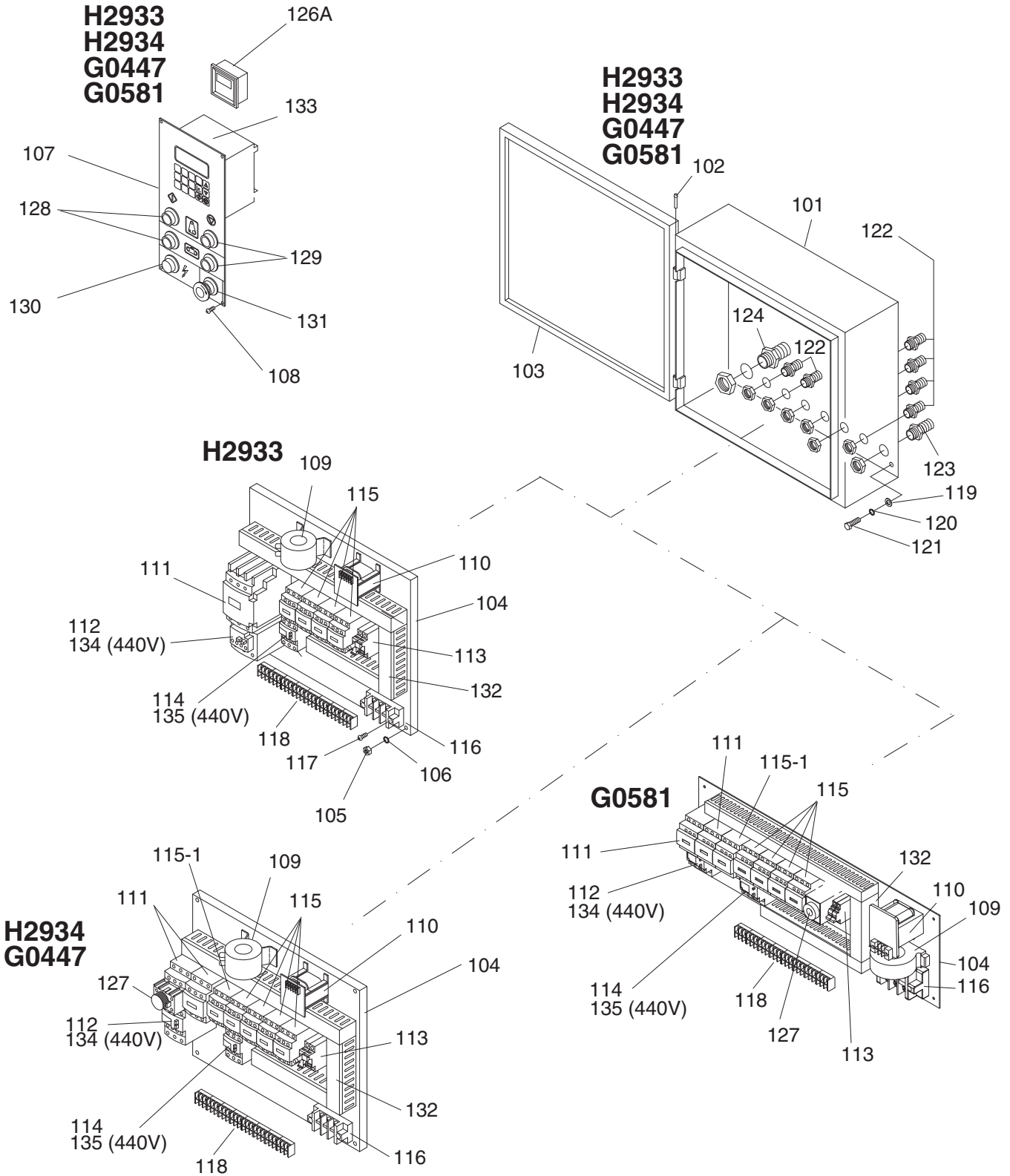

# Main Electrical Panel and Controls Parts List

REF	PART #	DESCRIPTION
101	PH29338101	ELECTRICAL CONTROL BOX (H2933)
101	PH29348101	ELECTRICAL CONTROL BOX (H2934/G0447)
101	P05818101	ELECTRICAL CONTROL BOX (G0581)
102	PH29338102	HINGE
103	PH29338103	DOOR (H2933)
103	PH29348103	DOOR (H2934/G0447)
103	P05818103	DOOR (G0581)
104	PH29338104	BASE PLATE (H2933)
104	PH29348104	BASE PLATE (H2934/G0447)
104	P05818104	BASE PLATE (G0581)
105	PH29338105	HEX NUT 1/4-20
106	PH29338106	LOCK WASHER 1/4
107	PH29338107	CONTROL PANEL
108	PH29338108	PHLP HD SCR M4-.7 X 8
109	PH29338109	CURRENT SENSOR
110	PH29338110	TRANSFORMER
111	PH29338111	CONTACTOR LC1-D40 (H2933)
111	PH29348111	CONTACTOR LC1-D368 (H2934/G0447/G0581)
112	PH29338112	RELAY LR3-D3355 220V (30-40A)(H2933)
112	PH29348112	RELAY LR3-D326 220V (23-32A) (H2934/G0447)
112	P05818112	RELAY LR3D-D356 220V (30-38A) (G0581)
113	PH29338113	FUSE TE10.3 X 38 & 500V/4Ax2
114	PH29338114	RELAY LR3-086 220V (2.5-4A) (H2933/H2934/G0447)

REF	PART #	DESCRIPTION
114	P05818114	RELAY LR3D-126 220V (2.5-4A) (G0581)
115	PH29338115	CONTACTOR LC1-D096 (H2933)
115-1	PH29348115-1	CONTACTOR LC1-D256 (H2934/G0447)
115-1	P05818115-1	CONTACTOR LC1-D098 (G0581)
116	PH29338116	POWER WIRE TERMINAL (H2933)
116	PH29348116	POWER WIRE TERMINAL (H2934/G0447)
116	P05818116	POWER WIRE TERMINAL (G0581)
118	PH29338118	TERMINAL PLATE
119	PH29338119	FLAT WASHER 1/4
120	PH29338120	LOCK WASHER 1/4
121	PH29338121	HEX BOLT 1/4-20 X 1/2
122	PH29338122	PU CONNECTOR 1/2"
123	PH29338123	PU CONNECTOR 3/4"
124	PH29338124	CABLE CONNECTOR 1"
126A	PH29338126A	DIGITAL AMP METER N/S
127	PH29348127	START DELAY LADS2 (H2934/G0447)
127	P05818127	START DELAY TRD-N (STON BRAND) (G0581)
128	PH29338128	START SWITCH
129	PH29338129	STOP SWITCH
130	PH29338130	POWER INDICATION LIGHT
131	PH29338131	EMERGENCY STOP SWITCH
132	PH29338132	WIRE COLUMN (G0581)
132	P05818132	WIRE COLUMN (H2933/H2934/G0447)
133	PH29338133	COMPUTER

## G0447 440V Conversion Kit

139	PH29349139	440V CONVERSION KIT
134	PH29348134	OL RELAY SCHN LR3D21 12-18A
135	PH29338135	OL RELAY SCHN LR3D07 1.6-2.5A

## H2933 440V Conversion Kit

139V2	PH29339139V	440V CONVERSION KIT
134V2	PH29338134V	OL RELAY SCHN LR3D325 17-25A V2.04.13
135	PH29338135	OL RELAY SCHN LR3D07 1.6-2.5A

## G0581 440V Conversion Kit

139	P05819139	440V CONVERSION KIT
134	PH29348134	OL RELAY SCHN LR3D21 12-18A
135	PH29338114	OL RELAY SCHN LR3D08 2.5-4A

## H2934 440V Conversion Kit

139	PH29349139	440V CONVERSION KIT
134	PH29348134	OL RELAY SCHN LR3D21 12-18A
135	PH29338135	OL RELAY SCHN LR3D07 1.6-2.5A



# Belt Oscillation System Diagram

## 9000 Series Parts

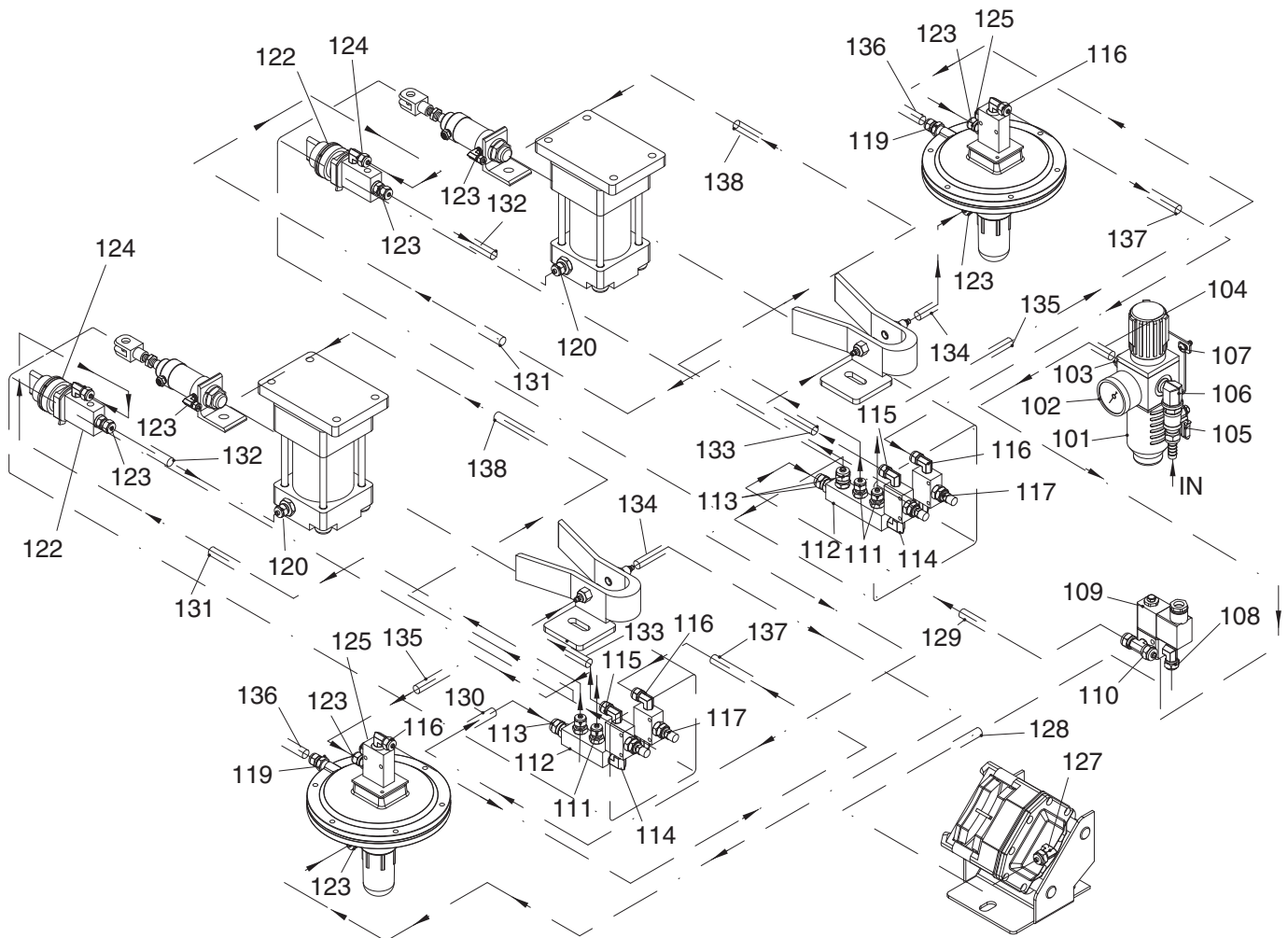

# Belt Oscillation System Parts List

REF	PART #	DESCRIPTION
101	PH29339101	FILTER CUP
102	PH29339102	REGULATOR W/GAUGE
103	PH29339103	BRONZE CONNECTOR
104	PH29339104	FLEXIBLE HOSE
105	PH29339105	AIR SWITCH
106	PH29339106	ELBOW
107	PH29339107	PHLP HD SCR 10-24 x 5/8
108	PH29339108	ELBOW 5/16N X 1/8T 90°
109	PH29339109	SOLENOID VALVE
110	PH29339110	T-FITTING 5/16N X 5/16N X 1/8T
111	PH29339111	CONNECTOR
112	PH29339112	MANIFOLD 1/4N 2-PORT
113	PH29339113	CONNECTOR 5/16N X 1/8T
114	PH29339114	ELBOW 1/4N X 1/4N 90°
115	PH29339115	CONNECTOR 1/4N X 1/8T 90°
116	PH29339116	CONNECTOR 1/4N X 1/8T 90°
117	PH29339117	THROTTLE VALVE
119	PH29339119	CONNECTOR 1/4N X 1/8T

REF	PART #	DESCRIPTION
120	PH29339120	CONNECTOR 3/8N X 1/8T
121	PH29339121	CONNECTOR 1/4N X 1/8T
122	PH29339122	AIR SWITCH
123	PH29339123	CONNECTOR 1/4N X 1/8T
124	PH29339124	CONNECTOR 1/4N X 1/8T 90°
125	PH29339125	BUFFER
127	PH29339127	CONNECTOR 5/16N X 1/8T 90°
128	PH29339128	8MM FLEXIBLE HOSE
129	PH29339129	6MM FLEXIBLE HOSE
131	PH29339131	6MM FLEXIBLE HOSE
132	PH29339132	6MM FLEXIBLE HOSE
133	PH29339133	6MM FLEXIBLE HOSE
134	PH29339134	6MM FLEXIBLE HOSE
135	PH29339135	6MM FLEXIBLE HOSE
136	PH29339136	6MM FLEXIBLE HOSE
137	PH29339137	6MM FLEXIBLE HOSE
138	PH29339138	6MM FLEXIBLE HOSE



# Machine Label Diagram

## 9000 Series Parts

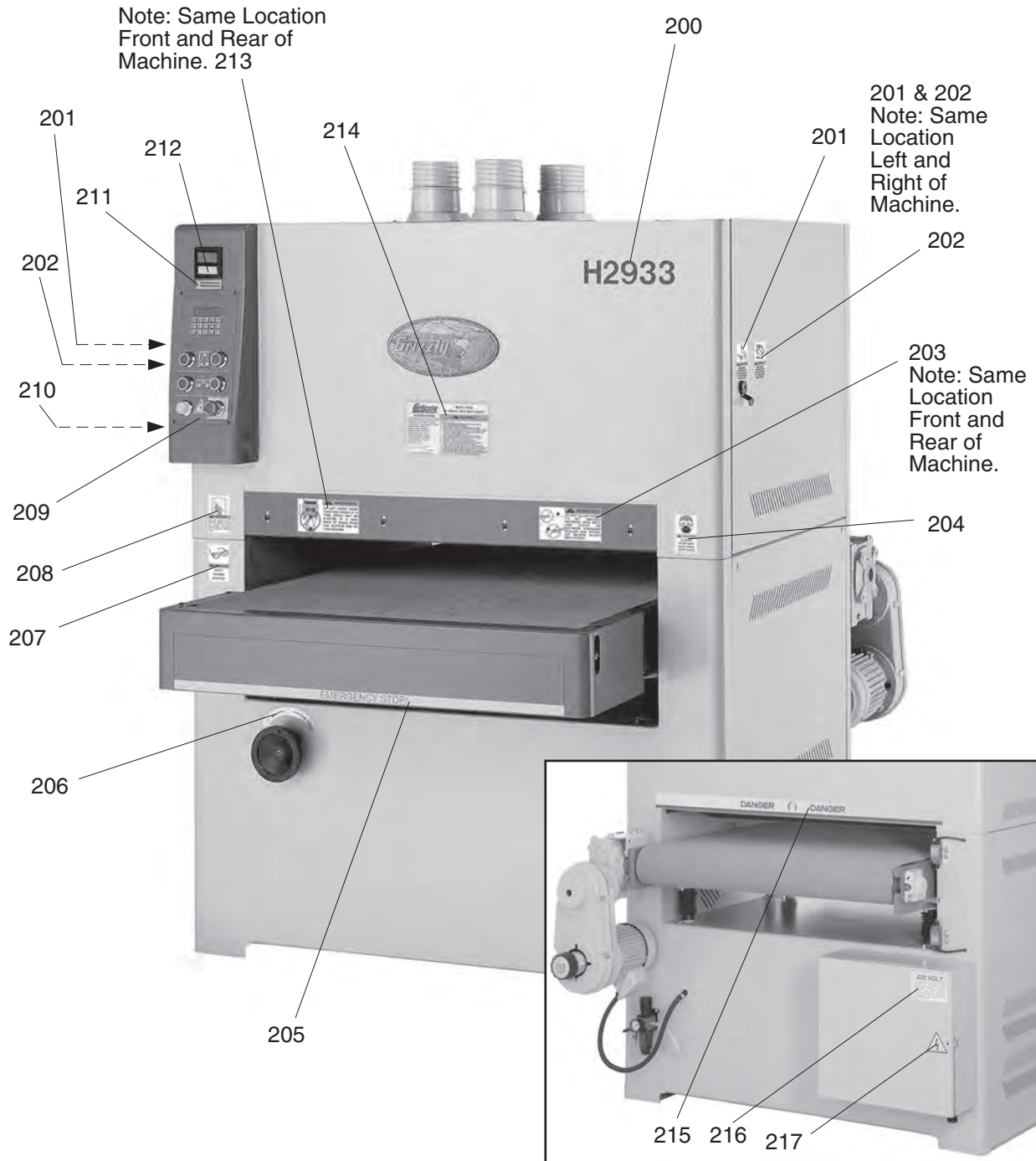

## **! WARNING**

Safety labels warn about machine hazards and ways to prevent injury. The owner of this machine **MUST** maintain the original location and readability of the labels on the machine. If any label is removed or becomes unreadable, **REPLACE** that label before using the machine again. Contact Grizzly at (800) 523-4777 or [www.grizzly.com](http://www.grizzly.com) to order new labels.



# Machine Label List

REF	PART #	DESCRIPTION
200	PH29339200	LABEL, MODEL H2933
200	PH29349200	LABEL, MODEL H2934
200	P04479200	LABEL, MODEL G0447
200	P05819200	LABEL, MODEL G0581
201	PH29339201	LABEL, UNPLUG SANDER
202	PH29339202	LABEL, DOOR CLOSED
203	PH29339203	LABEL, HAND PINCH IN BELT
204	PH29339204	LABEL, DUST MASK
205	PH29339205	LABEL, EMERGENCY STRIPE
206	PH29339206	LABEL, ROTATION LABEL
207	PH29339207	LABEL, SAFETY GLASSES
208	PH29339208	LABEL, READ MANUAL
209	PH29339209	LABEL, CONTROL PANEL FACE
210	PH29339210	LABEL, CONVERSION CHART

REF	PART #	DESCRIPTION
211	PH29339211	LABEL, H2933 AMP SCALE
211	PH29349211	LABEL, H2934 AMP SCALE
211	P04479211	LABEL, G0447 AMP SCALE
211	P05819211	LABEL, G0581 AMP SCALE
212	P02933212	LABEL, G0581 AMP SCALE
213	P02933213	LABEL, G0581 AMP SCALE
214	PH2933214	LABEL, G0581 AMP SCALE
214	PH29349214	LABEL, G0581 AMP SCALE
214	P04479214	LABEL, G0581 AMP SCALE
214	P05819214	LABEL, G0581 AMP SCALE
215	PH29339215	LABEL, G0581 AMP SCALE
216	PH29339216	LABEL, G0581 AMP SCALE
217	PH29339217	LABEL, G0581 AMP SCALE





# WARRANTY & RETURNS

---

---

Grizzly Industrial, Inc. warrants every product it sells for a period of **1 year** to the original purchaser from the date of purchase. This warranty does not apply to defects due directly or indirectly to misuse, abuse, negligence, accidents, repairs or alterations or lack of maintenance. This is Grizzly's sole written warranty and any and all warranties that may be implied by law, including any merchantability or fitness, for any particular purpose, are hereby limited to the duration of this written warranty. We do not warrant or represent that the merchandise complies with the provisions of any law or acts unless the manufacturer so warrants. In no event shall Grizzly's liability under this warranty exceed the purchase price paid for the product and any legal actions brought against Grizzly shall be tried in the State of Washington, County of Whatcom.

We shall in no event be liable for death, injuries to persons or property or for incidental, contingent, special, or consequential damages arising from the use of our products.

To take advantage of this warranty, contact us by mail or phone and give us all the details. We will then issue you a "Return Number," which must be clearly posted on the outside as well as the inside of the carton. We will not accept any item back without this number. Proof of purchase must accompany the merchandise.

The manufacturers reserve the right to change specifications at any time because they constantly strive to achieve better quality equipment. We make every effort to ensure that our products meet high quality and durability standards and we hope you never need to use this warranty.

Please feel free to write or call us if you have any questions about the machine or the manual.

Thank you again for your business and continued support. We hope to serve you again soon.





# WARRANTY CARD

Name \_\_\_\_\_

Street \_\_\_\_\_

City \_\_\_\_\_ State \_\_\_\_\_ Zip \_\_\_\_\_

Phone # \_\_\_\_\_ Email \_\_\_\_\_ Invoice # \_\_\_\_\_

Model # \_\_\_\_\_ Order # \_\_\_\_\_ Serial # \_\_\_\_\_

*The following information is given on a voluntary basis. It will be used for marketing purposes to help us develop better products and services. **Of course, all information is strictly confidential.***

1. How did you learn about us?

- Advertisement
- Card Deck
- Friend
- Website
- Catalog
- Other:

2. Which of the following magazines do you subscribe to?

- |   |  |   |
|---|--|---|
| <input type="checkbox"/> Cabinet Maker          | <input type="checkbox"/> Popular Mechanics   | <input type="checkbox"/> Today's Homeowner    |
| <input type="checkbox"/> Family Handyman        | <input type="checkbox"/> Popular Science     | <input type="checkbox"/> Wood                 |
| <input type="checkbox"/> Hand Loader            | <input type="checkbox"/> Popular Woodworking | <input type="checkbox"/> Wooden Boat          |
| <input type="checkbox"/> Handy                  | <input type="checkbox"/> Practical Homeowner | <input type="checkbox"/> Woodshop News        |
| <input type="checkbox"/> Home Shop Machinist    | <input type="checkbox"/> Precision Shooter   | <input type="checkbox"/> Woodsmith            |
| <input type="checkbox"/> Journal of Light Cont. | <input type="checkbox"/> Projects in Metal   | <input type="checkbox"/> Woodwork             |
| <input type="checkbox"/> Live Steam             | <input type="checkbox"/> RC Modeler          | <input type="checkbox"/> Woodworker West      |
| <input type="checkbox"/> Model Airplane News    | <input type="checkbox"/> Rifle               | <input type="checkbox"/> Woodworker's Journal |
| <input type="checkbox"/> Modeltec               | <input type="checkbox"/> Shop Notes          | <input type="checkbox"/> Other:               |
| <input type="checkbox"/> Old House Journal      | <input type="checkbox"/> Shotgun News        |   |

3. What is your annual household income?

- \$20,000-\$29,000
- \$30,000-\$39,000
- \$40,000-\$49,000
- \$50,000-\$59,000
- \$60,000-\$69,000
- \$70,000+

4. What is your age group?

- 20-29
- 30-39
- 40-49
- 50-59
- 60-69
- 70+

5. How long have you been a woodworker/metalworker?

- 0-2 Years
- 2-8 Years
- 8-20 Years
- 20+ Years

6. How many of your machines or tools are Grizzly?

- 0-2
- 3-5
- 6-9
- 10+

7. Do you think your machine represents a good value?  Yes  No

8. Would you recommend Grizzly Industrial to a friend?  Yes  No

9. Would you allow us to use your name as a reference for Grizzly customers in your area?  
Note: *We never use names more than 3 times.*  Yes  No

10. Comments: \_\_\_\_\_

\_\_\_\_\_

\_\_\_\_\_

\_\_\_\_\_

CUT ALONG DOTTED LINE

FOLD ALONG DOTTED LINE

\_\_\_\_\_  
\_\_\_\_\_  
\_\_\_\_\_



Place  
Stamp  
Here



**GRIZZLY INDUSTRIAL, INC.**  
**P.O. BOX 2069**  
**BELLINGHAM, WA 98227-2069**



FOLD ALONG DOTTED LINE

Send a Grizzly Catalog to a friend:

Name \_\_\_\_\_  
Street \_\_\_\_\_  
City \_\_\_\_\_ State \_\_\_\_\_ Zip \_\_\_\_\_

TAPE ALONG EDGES--PLEASE DO NOT STAPLE



# *grizzly.com*

**TOOL WEBSITE**

Buy Direct and Save with Grizzly® – Trusted, Proven and a Great Value!

*Visit Our Website Today And Discover Why  
Grizzly® Is The Industry Leader!*

- SECURE ORDERING
- ORDERS SHIPPED WITHIN 24 HOURS
- E-MAIL RESPONSE WITHIN ONE HOUR

-OR-

Call Today For A **FREE**  
Full Color Catalog

**1-800-523-4777**

