

Grizzly *Industrial, Inc.*®

MODEL G5912Z/G7214Z HEAVY-DUTY SHAPER

OWNER'S MANUAL

(For models manufactured since 01/17)



COPYRIGHT © 2001 BY GRIZZLY INDUSTRIAL, INC., REVISED MARCH, 2019 (MN)
**WARNING: NO PORTION OF THIS MANUAL MAY BE REPRODUCED IN ANY SHAPE
OR FORM WITHOUT THE WRITTEN APPROVAL OF GRIZZLY INDUSTRIAL, INC.**

#TR3250 PRINTED IN TAIWAN

V4.03.19



WARNING!

This manual provides critical safety instructions on the proper setup, operation, maintenance, and service of this machine/tool. Save this document, refer to it often, and use it to instruct other operators.

Failure to read, understand and follow the instructions in this manual may result in fire or serious personal injury—including amputation, electrocution, or death.

The owner of this machine/tool is solely responsible for its safe use. This responsibility includes but is not limited to proper installation in a safe environment, personnel training and usage authorization, proper inspection and maintenance, manual availability and comprehension, application of safety devices, cutting/sanding/grinding tool integrity, and the usage of personal protective equipment.

The manufacturer will not be held liable for injury or property damage from negligence, improper training, machine modifications or misuse.



WARNING!

Some dust created by power sanding, sawing, grinding, drilling, and other construction activities contains chemicals known to the State of California to cause cancer, birth defects or other reproductive harm. Some examples of these chemicals are:

- **Lead from lead-based paints.**
- **Crystalline silica from bricks, cement and other masonry products.**
- **Arsenic and chromium from chemically-treated lumber.**

Your risk from these exposures varies, depending on how often you do this type of work. To reduce your exposure to these chemicals: Work in a well ventilated area, and work with approved safety equipment, such as those dust masks that are specially designed to filter out microscopic particles.

Table of Contents

INTRODUCTION	2	SECTION 5: OPERATIONS	25
Contact Info.....	2	Rotation.....	25
Manual Accuracy	2	Cutter Installation	26
G5912Z Machine Data Sheet	3	Spindle Height.....	27
G7214Z Machine Data Sheet	5	Straight Shaping	27
SECTION 1: SAFETY	7	Rub Collars	29
Safety Instructions for Machinery	7	Pattern Work.....	30
Additional Safety for Shapers	9	Freehand Shaping	31
SECTION 2: POWER SUPPLY	10	Shop Made Shaper Accessories	31
440V Conversion	12	SECTION 6: ACCESSORIES	32
SECTION 3: SETUP	13	SECTION 7: MAINTENANCE	34
Needed for Setup.....	13	Schedule	34
Unpacking	13	Cleaning.....	34
Inventory	14	Unpainted Cast Iron.....	34
Cleanup.....	15	V-Belt	34
Site Considerations.....	15	SECTION 8: WIRING	35
Spindle	16	Wiring Safety Instructions	35
Handles.....	17	G5912Z Wiring Diagram	36
Guard	18	G7214Z Wiring Diagram	37
Fence Assembly	18	SECTION 9: PARTS	38
Guard Cover	19	Cabinet.....	38
Spindle Enclosure Guard.....	19	Spindle	40
Handwheel Handle.....	20	Motor	42
Hold-Downs	20	Fence Guard	44
SECTION 4: ADJUSTMENTS	21	Labels & Cosmetics	46
Pulleys & V-Belt	21	WARRANTY & RETURNS	49
V-Belt Tension	22		
Speed Changes	22		
Fence Adjustment.....	23		
Aligning The Fences	23		
Table Inserts	24		
Test Run	24		

INTRODUCTION

Contact Info

We stand behind our machines! If you have questions or need help, contact us with the information below. Before contacting, make sure you get the **serial number** and **manufacture date** from the machine ID label. This will help us help you faster.

Grizzly Technical Support
1815 W. Battlefield
Springfield, MO 65807
Phone: (570) 546-9663
Email: techsupport@grizzly.com

We want your feedback on this manual. What did you like about it? Where could it be improved? Please take a few minutes to give us feedback.

Grizzly Documentation Manager
P.O. Box 2069
Bellingham, WA 98227-2069
Email: manuals@grizzly.com

Manual Accuracy

We are proud to provide a high-quality owner's manual with your new machine!

We made every effort to be exact with the instructions, specifications, drawings, and photographs in this manual. Sometimes we make mistakes, but our policy of continuous improvement also means that **sometimes the machine you receive is slightly different than shown in the manual.**

If you find this to be the case, and the difference between the manual and machine leaves you confused or unsure about something, check our website for an updated version. We post current manuals and manual updates for free on our website at www.grizzly.com.

Alternatively, you can call our Technical Support for help. Before calling, make sure you write down the **Manufacture Date** and **Serial Number** from the machine ID label (see below). This information is required for us to provide proper tech support, and it helps us determine if updated documentation is available for your machine.

		MODEL GXXXX MACHINE NAME	
SPECIFICATIONS		▲ WARNING!	
Motor:	To reduce risk of serious injury when using this machine:		
Specification:	Read manual before operation.		
Specification:	Wear safety glasses and respirator.		
Specification:	Ensure safety glasses/respirator are properly adjusted/setup and		
Specification:	power is connected to grounded circuit before starting.		
Weight:	4. Make sure the motor has stopped and disconnect power before adjustments, maintenance, or service.		
	5. DO NOT expose to rain or dampness.		
	6. DO NOT modify this machine in any way.		
	7.		
	8.		
	9. Do not use while under the influence of drugs or alcohol.		
	10. Maintain machine carefully to prevent accidents.		
Manufactured for Grizzly in Taiwan			

Manufacture Date

Serial Number





MACHINE DATA SHEET

Customer Service #: (570) 546-9663 · To Order Call: (800) 523-4777 · Fax #: (800) 438-5901

MODEL G5912Z 5 HP PROFESSIONAL SPINDLE SHAPER - Z SERIES

Product Dimensions:

Weight..... 562 lbs.
 Width (side-to-side) x Depth (front-to-back) x Height..... 34-3/4 x 35-1/2 x 42 in.
 Footprint (Length x Width)..... 26 x 27 in.

Shipping Dimensions:

Type..... Wood Crate
 Content..... Machine
 Weight..... 604 lbs.
 Length x Width x Height..... 40 x 30 x 43 in.
 Must Ship Upright..... Yes

Electrical:

Power Requirement..... 220V, Single-Phase, 60 Hz
 Prewired Voltage..... 220V
 Full-Load Current Rating..... 25A
 Minimum Circuit Size..... 30A
 Connection Type..... Cord & Plug
 Power Cord Included..... No
 Recommended Power Cord..... "S"-Type, 3-Wire, 10 AWG, 300 VAC
 Recommended Plug Type..... L6-30
 Switch Type..... Control Panel w/Magnetic Switch Protection

Motors:

Main

Horsepower..... 5 HP
 Phase..... Single-Phase
 Amps..... 25A
 Speed..... 3450 RPM
 Type..... TEFC Capacitor-Start Induction
 Power Transfer..... Belt Drive
 Bearings..... Shielded & Permanently Lubricated
 Centrifugal Switch/Contacts Type..... External

Main Specifications:

Operation Info

Max. Cutter Height..... 5-1/8 in.
 Max. Cutter Diameter..... 5-7/8 in.
 Spindle Sizes..... 3/4, 1, 1-1/4 in.
 Spindle Lengths..... 6 - 7 in.
 Exposed Spindle Length..... 5-7/8 – 6-7/8 in.
 Spindle Cap. Under the Nut..... 4-1/4, 4-5/8, 5-1/8 in.
 Spindle Speeds..... 3600, 5100, 8000, 10,000 RPM
 Spindle Travel..... 3-1/4 in.
 Spindle Openings..... 2, 3, 3-1/2, 7 in.



Table Info

Number of Table Inserts.....	3
Table Insert Sizes I.D.....	2, 3, 3-1/2 in.
Table Insert Sizes O.D.....	3, 3-1/2, 7 in.
Table Counterbore Diameter.....	7 in.
Table Counterbore Depth.....	5/8 in.
Table Size Length.....	35-1/2 in.
Table Size Width.....	28 in.
Table Size Thickness.....	2-5/16 in.
Floor to Table Height.....	34-3/4 in.
Table Fence Length.....	33-3/8 in.
Table Fence Width.....	9/16 in.
Table Fence Height.....	4-1/4 in.

Miter Gauge Info

Miter Angle.....	0 – 60 deg. L/R
Miter Gauge Slot Type.....	T-Slot
Miter Gauge Slot Width.....	1 in.
Miter Gauge Slot Height.....	9/16 in.

Construction

Table.....	Precision-Ground Cast Iron
Body Assembly.....	Cast Iron
Cabinet.....	Formed Steel
Fence.....	Cast Iron with Wood
Miter Gauge.....	Cast Iron
Guard.....	Cast Iron
Spindle Bearings.....	Sealed & Lubricated
Paint Type/Finish.....	Powder Coated

Other

Number of Dust Ports.....	1
Dust Port Size.....	4 in.
Mobile Base.....	D2058A

Other Specifications:

Country of Origin	Taiwan
Warranty	1 Year
Approximate Assembly & Setup Time	45 Minutes
Serial Number Location	ID Label on Stand
ISO 9001 Factory	No
Certified by a Nationally Recognized Testing Laboratory (NRTL)	No

Features:

- Cast-Iron Miter Gauge, Adjustable 60 deg. Left to 60 deg. Right
- Precision-Ground Cast-Iron Table
- Green Epoxy Paint
- Fence Adjustment Includes Built-In Ratchets and Knob-Equipped Adjusters
- 2 Wood Fence Pieces Included
- 3 Spindles with 8 Spacers and 2 Nuts Included
- Spindles Include Spacer and Nuts
- Spindle Height Scale in Inches and Millimeters
- 4 Spring Steel Hold-Down Assemblies
- Assorted Wrenches Included





MACHINE DATA SHEET

Customer Service #: (570) 546-9663 · To Order Call: (800) 523-4777 · Fax #: (800) 438-5901

MODEL G7214Z 7-1/2 HP 3-PHASE SPINDLE SHAPER

Product Dimensions:

Weight..... 573 lbs.
 Width (side-to-side) x Depth (front-to-back) x Height..... 34-3/4 x 35-1/2 x 43 in.
 Footprint (Length x Width)..... 26 x 27 in.

Shipping Dimensions:

Type..... Wood Crate
 Content..... Machine
 Weight..... 613 lbs.
 Length x Width x Height..... 40 x 30 x 43 in.
 Must Ship Upright..... Yes

Electrical:

Power Requirement..... 220V or 440V, 3-Phase, 60 Hz
 Prewired Voltage..... 220V
 Full-Load Current Rating..... 20A at 220V, 10A at 440V
 Minimum Circuit Size..... 30A at 220V, 15A at 440V
 Connection Type..... Cord at 220V, Permanently Connected at 440V
 Power Cord Included..... No
 Recommended Power Cord..... "S"-Type, 4-Wire, 10 AWG, 300 VAC for 220V
 Recommended Plug Type..... L15-30 for 220V
 Switch Type..... Control Panel w/Magnetic Switch Protection
 Voltage Conversion Kit..... P7214Z156 for 440V
 Recommended Phase Converter..... G7978

Motors:

Main

Horsepower..... 7.5 HP
 Phase..... 3-Phase
 Amps..... 20A/10A
 Speed..... 3450 RPM
 Type..... TEFC Induction
 Power Transfer..... Belt Drive
 Bearings..... Shielded & Permanently Lubricated
 Centrifugal Switch/Contacts Type..... N/A

Main Specifications:

Operation Info

Max. Cutter Height..... 5-1/8 in.
 Max. Cutter Diameter..... 5-7/8 in.
 Spindle Sizes..... 3/4, 1, 1-1/4 in.
 Spindle Lengths..... 6 - 7 in.
 Exposed Spindle Length..... 5-7/8 – 6-7/8 in.
 Spindle Cap. Under the Nut..... 4-1/4, 4-5/8, 5-1/8 in.
 Spindle Speeds..... 3600, 5100, 8000, 10,000 RPM
 Spindle Travel..... 3-1/4 in.
 Spindle Openings..... 2, 3, 3-1/2, 7 in.



Table Info

Number of Table Inserts.....	3
Table Insert Sizes I.D.....	2, 3, 3-1/2 in.
Table Insert Sizes O.D.....	3, 3-1/2, 7 in.
Table Counterbore Diameter.....	7 in.
Table Counterbore Depth.....	5/8 in.
Table Size Length.....	35-1/2 in.
Table Size Width.....	28 in.
Table Size Thickness.....	2-5/16 in.
Floor to Table Height.....	34-3/4 in.
Table Fence Length.....	33-3/8 in.
Table Fence Width.....	9/16 in.
Table Fence Height.....	4-1/4 in.

Miter Gauge Info

Miter Angle.....	0 – 60 deg. L/R
Miter Gauge Slot Type.....	T-Slot
Miter Gauge Slot Width.....	1 in.
Miter Gauge Slot Height.....	9/16 in.

Construction

Table.....	Precision-Ground Cast Iron
Body Assembly.....	Cast Iron
Cabinet.....	Formed Steel
Fence.....	Cast Iron with Wood
Miter Gauge.....	Cast Iron
Guard.....	Cast Iron
Spindle Bearings.....	Sealed & Lubricated
Paint Type/Finish.....	Powder Coated

Other

Number of Dust Ports.....	1
Dust Port Size.....	4 in.
Mobile Base.....	D2058A

Other Specifications:

Country of Origin	Taiwan
Warranty	1 Year
Approximate Assembly & Setup Time	45 Minutes
Serial Number Location	ID Label on Stand
ISO 9001 Factory	No
Certified by a Nationally Recognized Testing Laboratory (NRTL)	No

Features:

- Cast-Iron Miter Gauge, Adjustable 60 deg. Left to 60 deg. Right
- Precision-Ground Cast-Iron Table
- Green Powder Coated Paint
- Fence Adjustment Includes Built-In Ratchets and Knob-Equipped Adjusters
- 3 Spindles with 8 Spacers and 2 Nuts Included
- Spindle Height Scale in Inches and Millimeters
- 2 Wood Fence Pieces Included
- 4 Spring Steel Hold-Down Assemblies
- Assorted Wrenches Included



SECTION 1: SAFETY

For Your Own Safety, Read Instruction Manual Before Operating This Machine

The purpose of safety symbols is to attract your attention to possible hazardous conditions. This manual uses a series of symbols and signal words intended to convey the level of importance of the safety messages. The progression of symbols is described below. Remember that safety messages by themselves do not eliminate danger and are not a substitute for proper accident prevention measures. Always use common sense and good judgment.

 **DANGER** Indicates an imminently hazardous situation which, if not avoided, **WILL** result in death or serious injury.

 **WARNING** Indicates a potentially hazardous situation which, if not avoided, **COULD** result in death or serious injury.

 **CAUTION** Indicates a potentially hazardous situation which, if not avoided, **MAY** result in minor or moderate injury. It may also be used to alert against unsafe practices.

NOTICE Alerts the user to useful information about proper operation of the machine to avoid machine damage.

Safety Instructions for Machinery

WARNING

OWNER'S MANUAL. Read and understand this owner's manual **BEFORE** using machine.

TRAINED OPERATORS ONLY. Untrained operators have a higher risk of being hurt or killed. Only allow trained/supervised people to use this machine. When machine is not being used, disconnect power, remove switch keys, or lock-out machine to prevent unauthorized use—especially around children. Make your workshop kid proof!

DANGEROUS ENVIRONMENTS. Do not use machinery in areas that are wet, cluttered, or have poor lighting. Operating machinery in these areas greatly increases the risk of accidents and injury.

MENTAL ALERTNESS REQUIRED. Full mental alertness is required for safe operation of machinery. Never operate under the influence of drugs or alcohol, when tired, or when distracted.

ELECTRICAL EQUIPMENT INJURY RISKS. You can be shocked, burned, or killed by touching live electrical components or improperly grounded machinery. To reduce this risk, only allow qualified service personnel to do electrical installation or repair work, and always disconnect power before accessing or exposing electrical equipment.

DISCONNECT POWER FIRST. Always disconnect machine from power supply **BEFORE** making adjustments, changing tooling, or servicing machine. This prevents an injury risk from unintended startup or contact with live electrical components.

EYE PROTECTION. Always wear ANSI-approved safety glasses or a face shield when operating or observing machinery to reduce the risk of eye injury or blindness from flying particles. Everyday eyeglasses are **NOT** approved safety glasses.



WARNING

WEARING PROPER APPAREL. Do not wear clothing, apparel or jewelry that can become entangled in moving parts. Always tie back or cover long hair. Wear non-slip footwear to reduce risk of slipping and losing control or accidentally contacting cutting tool or moving parts.

HAZARDOUS DUST. Dust created by machinery operations may cause cancer, birth defects, or long-term respiratory damage. Be aware of dust hazards associated with each workpiece material. Always wear a NIOSH-approved respirator to reduce your risk.

HEARING PROTECTION. Always wear hearing protection when operating or observing loud machinery. Extended exposure to this noise without hearing protection can cause permanent hearing loss.

REMOVE ADJUSTING TOOLS. Tools left on machinery can become dangerous projectiles upon startup. Never leave chuck keys, wrenches, or any other tools on machine. Always verify removal before starting!

USE CORRECT TOOL FOR THE JOB. Only use this tool for its intended purpose—do not force it or an attachment to do a job for which it was not designed. Never make unapproved modifications—modifying tool or using it differently than intended may result in malfunction or mechanical failure that can lead to personal injury or death!

AWKWARD POSITIONS. Keep proper footing and balance at all times when operating machine. Do not overreach! Avoid awkward hand positions that make workpiece control difficult or increase the risk of accidental injury.

CHILDREN & BYSTANDERS. Keep children and bystanders at a safe distance from the work area. Stop using machine if they become a distraction.

GUARDS & COVERS. Guards and covers reduce accidental contact with moving parts or flying debris. Make sure they are properly installed, undamaged, and working correctly **BEFORE** operating machine.

FORCING MACHINERY. Do not force machine. It will do the job safer and better at the rate for which it was designed.

NEVER STAND ON MACHINE. Serious injury may occur if machine is tipped or if the cutting tool is unintentionally contacted.

STABLE MACHINE. Unexpected movement during operation greatly increases risk of injury or loss of control. Before starting, verify machine is stable and mobile base (if used) is locked.

USE RECOMMENDED ACCESSORIES. Consult this owner's manual or the manufacturer for recommended accessories. Using improper accessories will increase the risk of serious injury.

UNATTENDED OPERATION. To reduce the risk of accidental injury, turn machine **OFF** and ensure all moving parts completely stop before walking away. Never leave machine running while unattended.

MAINTAIN WITH CARE. Follow all maintenance instructions and lubrication schedules to keep machine in good working condition. A machine that is improperly maintained could malfunction, leading to serious personal injury or death.

DAMAGED PARTS. Regularly inspect machine for damaged, loose, or mis-adjusted parts—or any condition that could affect safe operation. Immediately repair/replace **BEFORE** operating machine. For your own safety, **DO NOT** operate machine with damaged parts!

MAINTAIN POWER CORDS. When disconnecting cord-connected machines from power, grab and pull the plug—**NOT** the cord. Pulling the cord may damage the wires inside. Do not handle cord/plug with wet hands. Avoid cord damage by keeping it away from heated surfaces, high traffic areas, harsh chemicals, and wet/damp locations.

EXPERIENCING DIFFICULTIES. If at any time you experience difficulties performing the intended operation, stop using the machine! Contact our Technical Support at (570) 546-9663.



Additional Safety for Shapers

WARNING

Serious cuts, amputation, entanglement, or death can occur from contact with rotating cutter. Cutters or other parts improperly secured to spindle can fly off and strike nearby operators with great force. Flying debris can cause eye injuries or blindness. To minimize risk of getting hurt or killed, anyone operating shaper MUST completely heed hazards and warnings below.

AVOIDING CUTTER CONTACT: Keep unused portion of cutter below table. Use smallest table insert possible. Adjust fences and guards as close as practical to cutter, or use a zero-clearance fence or box guard. *Always keep some type of guard or other protective device between your hands and cutter at all times!*

PROTECT HANDS/FINGERS: While feeding workpiece, avoid awkward hand positions. Never pass hands directly over, or in front of, cutter. As one hand approaches a 6-inch radius point from cutter, move it in an arc motion away from cutter, and reposition it on the outfeed side.

FEEDING WORKPIECE: To reduce risk of accidental cutterhead contact, always use push blocks or some type of fixture, jig, or hold-down device to safely feed workpiece while cutting. Use an outfeed support table if shaping long workpieces to ensure proper support throughout entire cutting procedure. ALWAYS feed workpiece AGAINST rotation of cutter. NEVER start shaper with workpiece contacting cutter!

CUTTING DEPTH: Never attempt to remove too much material in one pass. Doing this increases risk of workpiece kickback. Instead, make several light passes—this is a safer way to cut and it leaves a cleaner finish.

WORKPIECE CONDITION: Shaping a workpiece with knots, holes, or foreign objects increases risk of kickback and cutter damage/breakage. Thoroughly inspect and prepare workpiece before shaping. Always “square up” a workpiece before shaping or flatten workpiece edges with a jointer or planer. Rough, warped, or wet workpieces increase risk of kickback.

CUTTER POSITIONING: Whenever possible, make shaping cuts with cutter on *underside* of workpiece to reduce operator exposure to cutter.

SMALL WORKPIECES: There is a high risk of accidental cutter contact with small workpieces, because they are closer to cutter and more difficult to control. To reduce your risk, only feed small workpieces using jigs or holding fixtures that allow your hands to stay safely away from cutter. When possible, shape longer stock and cut to size.

SAFE CUTTER CLEARANCES: Operator or bystanders may be hit by flying debris if cutter contacts fence, guard, or table insert upon startup. Always ensure any new cutter setup has proper cutter rotational clearance before startup.

SAFE CUTTER INSTALLATION: Improperly secured knives/inserts, cutters, or rub collars may become dangerous projectiles if they come loose. Always ensure keyed washer is directly under spindle nut and spindle nut is tight. If spindle does not use a keyed washer, always use two spindle nuts together, and ensure BOTH are tight. Never use cutters/bits rated for an RPM lower than spindle speed.

AVOIDING CLIMB CUTS: Feeding workpiece in same direction of cutter rotation is a “climb cut.” Climb cutting can aggressively pull workpiece—and hands—into cutter. Always first verify direction of cutter rotation before starting, and always feed workpiece AGAINST cutter rotation.

SAFETY GUARDS. To reduce risk of unintentional contact with cutter, always ensure included cutter guard, or a properly dimensioned box guard, or some other type of guard is installed and correctly positioned before operation.

CONTOUR SHAPING: To reduce risk of unintentional cutter contact while freehand shaping or using a rub collar as a guide, always use an overhead or “ring” type guard. To reduce kickback risk, always use starting pin or pivot board when starting the cut. NEVER start shaping at a corner!



SECTION 2: POWER SUPPLY

Availability

Before installing the machine, consider the availability and proximity of the required power supply circuit. If an existing circuit does not meet the requirements for this machine, a new circuit must be installed. To minimize the risk of electrocution, fire, or equipment damage, installation work and electrical wiring must be done by an electrician or qualified service personnel in accordance with all applicable codes and standards.

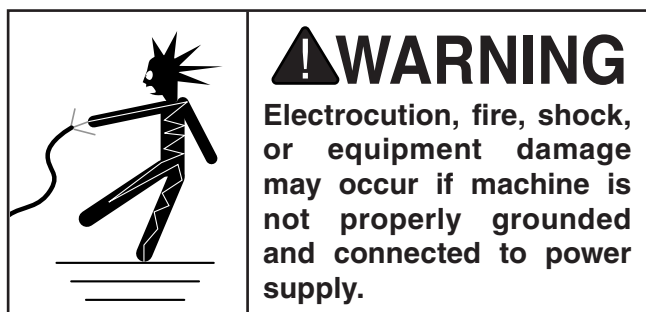

Full-Load Current Rating

The full-load current rating is the amperage a machine draws at 100% of the rated output power. On machines with multiple motors, this is the amperage drawn by the largest motor or sum of all motors and electrical devices that might operate at one time during normal operations.

G5912Z

Full-Load Current at 220V 25 Amps

G7214Z

Full-Load Current at 220V 20 Amps

Full-Load Current at 440V 10 Amps

The full-load current is not the maximum amount of amps that the machine will draw. If the machine is overloaded, it will draw additional amps beyond the full-load rating.

If the machine is overloaded for a sufficient length of time, damage, overheating, or fire may result—especially if connected to an undersized circuit. To reduce the risk of these hazards, avoid overloading the machine during operation and make sure it is connected to a power supply circuit that meets the specified circuit requirements.

Circuit Information

A power supply circuit includes all electrical equipment between the breaker box or fuse panel in the building and the machine. The power supply circuit used for this machine must be sized to safely handle the full-load current drawn from the machine for an extended period of time. (If this machine is connected to a circuit protected by fuses, use a time delay fuse marked D.)



Note: Circuit requirements in this manual apply to a dedicated circuit—where only one machine will be running on the circuit at a time. If machine will be connected to a shared circuit where multiple machines may be running at the same time, consult an electrician or qualified service personnel to ensure circuit is properly sized for safe operation.

Grounding Instructions

In the event of a malfunction or breakdown, grounding provides a path of least resistance for electrical current to reduce the risk of electric shock. A permanently connected machine must be connected to a grounded metal permanent wiring system; or to a system having an equipment-grounding conductor. All grounds must be verified and rated for the electrical requirements of the machine. Improper grounding can increase the risk of electric shock!



Model G5912Z Circuit Requirements

This machine is prewired to operate on a power supply circuit that has a verified ground and meets the following requirements:

Nominal Voltage208V, 220V, 230V, 240V
Cycle.....60 Hz
Phase..... Single-Phase
Power Supply Circuit..... 30 Amps
Plug/ReceptacleNEMA L6-30
Cord.....“S”-Type, 3-Wire, 10 AWG, 300 VAC

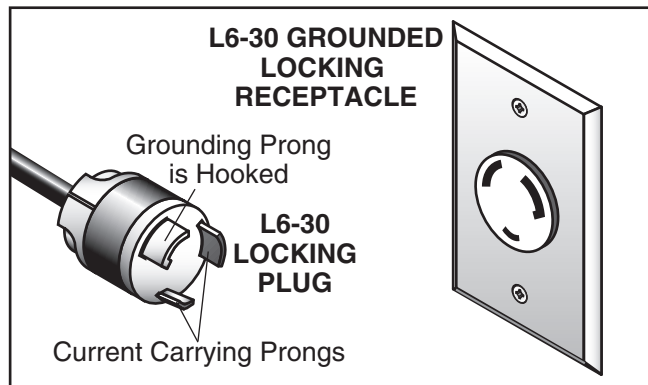

Figure 1. Typical L6-30 plug and receptacle.

Model G7214Z Circuit Requirements for 220V

This machine is prewired to operate on a power supply circuit that has a verified ground and meets the following requirements:

Nominal Voltage208V, 220V, 230V, 240V
Cycle.....60 Hz
Phase..... 3-Phase
Power Supply Circuit..... 30 Amps
Plug/Receptacle NEMA L15-30
Cord.....“S”-Type, 4-Wire, 10 AWG, 300 VAC

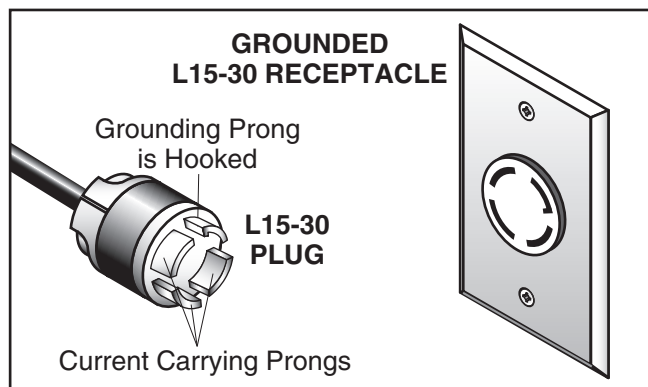

Figure 2. Typical L15-30 plug and receptacle.

Model G7214Z Circuit Requirements for 440V

This machine can be converted to operate on a power supply circuit that has a verified ground and meets the requirements listed below. (Refer to **Voltage Conversion** instructions for details.)

Nominal Voltage 440V, 480V
Cycle.....60 Hz
Phase..... 3-Phase
Power Supply Circuit 15 Amps
Connection..... Hardwire with Locking Switch

A permanently connected (hardwired) power supply is typically installed with wires running through mounted and secured conduit. A disconnecting means, such as a locking switch (see following figure), must be provided to allow the machine to be disconnected (isolated) from the power supply when required. This installation must be performed by an electrician in accordance with all applicable electrical codes and ordinances.

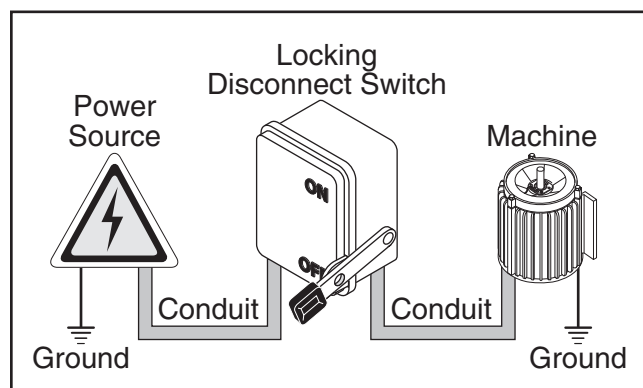

Figure 3. Typical setup of a permanently connected machine.

Extension Cords

Since this machine must be permanently connected to the power supply, an extension cord cannot be used.



440V Conversion

The Model G7214Z can be converted for 440V operation using the optional Part# P7214Z156A. This can be purchased by contacting the Grizzly Order Desk at (800) 523-4777. This conversion job consists of: 1) replacing the magnetic switch assembly and 2) rewiring the motor for 440V operation.

All wiring changes must be done by an electrician or qualified service personnel before the shaper is connected to the power source. If, at any time during this procedure you need help, call Grizzly Tech Support at (570) 546-9663.

To convert G7214Z for 440V operation:

1. DISCONNECT SHAPER FROM POWER!
2. Remove the control panel cover and carefully rotate it to expose the electrical components attached to the backside.
3. Replace the existing magnetic switch assembly (see **Figure 4**) with the magnetic switch assembly from the 440V conversion kit.

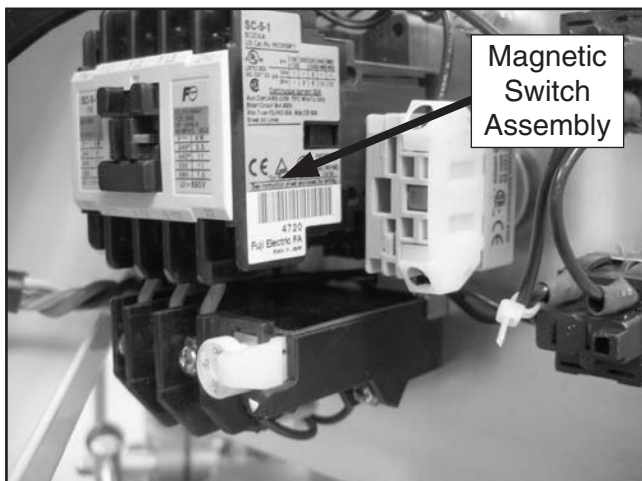

Figure 4. Magnetic switch assembly

4. Replace the control panel cover.
5. Remove the cabinet cover to gain access to the motor inside the cabinet.
6. Remove the junction box cover from the motor, and review the diagram on the inside of that cover.
7. Wire the motor as indicated on the diagram for 440V (or high voltage).
8. Replace the junction box cover and cabinet covers.

⚠ CAUTION

No list of safety guidelines can be complete. Every shop environment is different. Always consider safety first, as it applies to your individual working conditions. Use this and other machinery with caution and respect. Failure to do so could result in serious personal injury, damage to equipment, or poor work results.



SECTION 3: SETUP

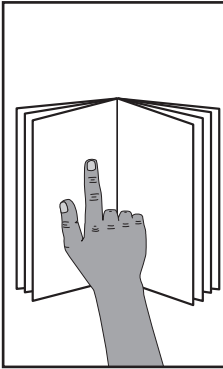

!WARNING

This machine presents serious injury hazards to untrained users. Read through this entire manual to become familiar with the controls and operations before starting the machine!

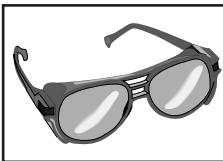

!WARNING

Wear safety glasses during the entire setup process!

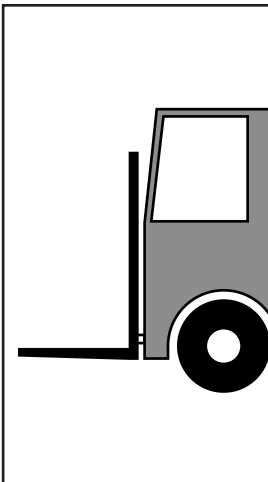

!WARNING

The G5912Z/G7214Z is a heavy machine. **DO NOT** over-exert yourself while unpacking or moving your machine – use power equipment to move the machine. Serious personal injury may occur if safe moving methods are not followed.

!WARNING

Like all machines there is danger associated with **THIS** machine. Accidents are frequently caused by lack of familiarity or failure to pay attention. Use this machine with respect and caution to lessen the possibility of operator injury. If normal safety precautions are overlooked or ignored, serious personal injury may occur.

Needed for Setup

The following items are needed, but not included, for the setup/assembly of this machine.

Description	Qty
• Straightedge 4' (or longer)	1
• Safety Glasses (for each person)	1
• Dust Collection System	1
• 4" Dust Hose (length as needed)	1
• 4" Hose Clamp	1
• Open-End Wrench 12mm	1
• Open-End Wrench 14mm	1
• Open-End Wrench 15mm	1
• Hex Wrench 4mm	1

Unpacking

This machine was carefully packaged for safe transport. When unpacking, separate all enclosed items from packaging materials and inspect them for shipping damage. ***If items are damaged, please call us immediately at (570) 546-9663.***

IMPORTANT: Save all packaging materials until you are completely satisfied with the machine and have resolved any issues between Grizzly or the shipping agent. ***You MUST have the original packaging to file a freight claim. It is also extremely helpful if you need to return your machine later.***



Inventory

The following is a list of items shipped with your machine. Before beginning setup, lay these items out and inventory them.

If any non-proprietary parts are missing (e.g. a nut or a washer), we will gladly replace them; or for the sake of expediency, replacements can be obtained at your local hardware store.

NOTICE

If you cannot find an item on this list, carefully check around/inside the machine and packaging materials. Often, these items get lost in packaging materials while unpacking or they are pre-installed at the factory.

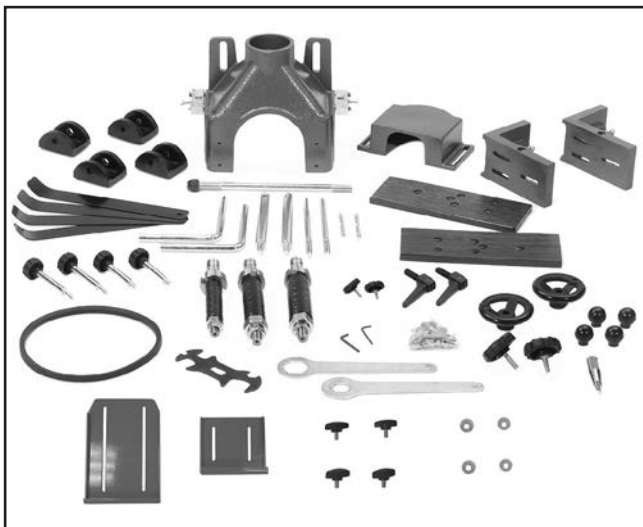

Figure 5. G5912Z/G7214Z inventory.

Model G5912Z/G7214Z Inventory	Qty
• 3/4" Spindle	1
• 1" Spindle	1
• 1 1/4" Spindle	1
• 3/4" Spindle Nut	2
• 1" Spindle Nut	2
• 1 1/4" Spindle Nut	2
• Spacer Set.....	22
• Hold-Downs	4
• Hold-Down Bars	2
• Hold-Down Brackets.....	4
• Fence Pieces.....	2
• Fence Mounts.....	2
• Cutter Guard.....	1
• Cutter Guard Cover	1
• Multi Wrench 10, 19, 23, 26, 37mm.....	1
• Hex Wrench 3mm	1
• Hex Wrench 4mm	1
• Spindle Wrench 1 1/2"	1
• Spindle Wrench 1"	1
• Stainless Wheel Handles	1
• Round Knobs.....	4
• Plastic Adjustment Wheels.....	2
• 4" Threaded Stud Knobs.....	2
• 4 7/8" Threaded Stud Knobs.....	2
• 4" Double Threaded-End Bars	2
• Draw Bar w/Nut	1
• Shaft Guide Bar w/Set Screw	2
• Fence-Bracket Adjustment Handles.....	2
• Hold-Down Adjustment Handles	2
• Adjustment Guide Bar	2
• Threaded Spacers.....	2
• Lock Washers 5/16"	6
• 5/16"-18 x 1 5/16" Flat Head Screws.....	6
• 5/16" Flat Washers.....	8
• 1/2" Flat Washers.....	4
• 5/16" Hex Nuts	6
• T-Type Nuts.....	2
• V-Belt A28	1
• Knob Bolts 3/8"-16 x 1	2
• Front Spindle Enclosure Guard.....	1
• Front Guard Extension Plate.....	1
• Knob Bolts 1/4"-20 x 1/2"	4
• Flat Washers 1/4"	4



Cleanup

The unpainted surfaces of your machine are coated with a heavy-duty rust preventative that prevents corrosion during shipment and storage. This rust preventative works extremely well, but it will take a little time to clean.

Be patient and do a thorough job cleaning your machine. The time you spend doing this now will give you a better appreciation for the proper care of your machine's unpainted surfaces.

There are many ways to remove this rust preventative, but the following steps work well in a wide variety of situations. Always follow the manufacturer's instructions with any cleaning product you use and make sure you work in a well-ventilated area to minimize exposure to toxic fumes.

Before cleaning, gather the following:

- Disposable rags
- Cleaner/degreaser (WD-40 works well)
- Safety glasses & disposable gloves
- Plastic paint scraper (optional)

Basic steps for removing rust preventative:

1. Put on safety glasses.
2. Coat the rust preventative with a liberal amount of cleaner/degreaser, then let it soak for 5–10 minutes.
3. Wipe off the surfaces. If your cleaner/degreaser is effective, the rust preventative will wipe off easily. If you have a plastic paint scraper, scrape off as much as you can first, then wipe off the rest with the rag.
4. Repeat **Steps 2–3** as necessary until clean, then coat all unpainted surfaces with a quality metal protectant to prevent rust.

NOTICE

Avoid harsh solvents like acetone or brake parts cleaner that may damage painted surfaces. Always test on a small, inconspicuous location first.

Site Considerations

Floor Load

Refer to the **Machine Data Sheet** for the weight and footprint specifications of your machine. Some residential floors may require additional reinforcement to support both the machine and operator.

Placement Location

Consider anticipated workpiece sizes and additional space needed for auxiliary stands, work tables, or other machinery when establishing a location for this machine in the shop. Below is the minimum amount of space needed for the machine.

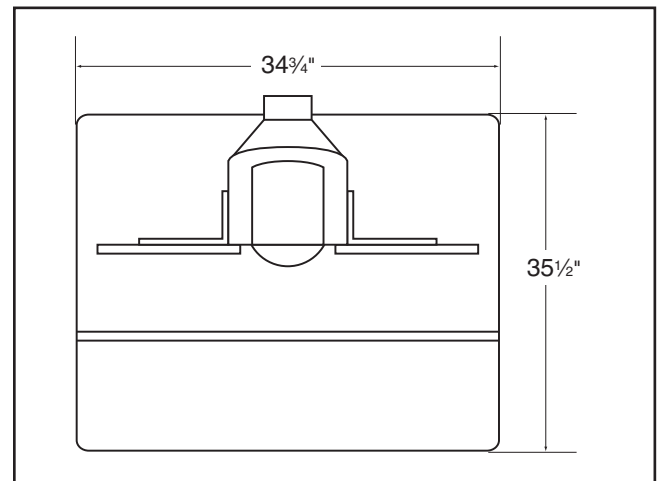
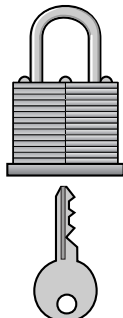

Figure 6. Minimum working clearances.

	<p>CAUTION</p> <p>Children and visitors may be seriously injured if unsupervised around this machine. Lock entrances to the shop or disable start switch or power connection to prevent unsupervised use.</p>
--	--



Spindle

The Model G5912Z/G7214Z comes with three interchangeable spindles like those in **Figure 7**. The spindles must be inserted correctly and remain stable in order to produce quality work. When installing and changing spindles, make sure the spindle seats snugly and that there is enough drawbar threaded into the bottom of the spindle to safely secure it in place.

To install a spindle:

1. DISCONNECT SHAPER FROM POWER!



Figure 7. 1/2", 3/4", & 1" spindles.

2. Thread the drawbar approximately 10-15 turns into the bottom of the spindle. The drawbar has two threaded ends. One of them will remain exposed.
3. Drop the spindle/drawbar into the spindle cartridge at the top of the table. Line up the notches at the top of the spindle cartridge with those in the spindle as shown in **Figure 8**. You will feel the spindle seat itself.

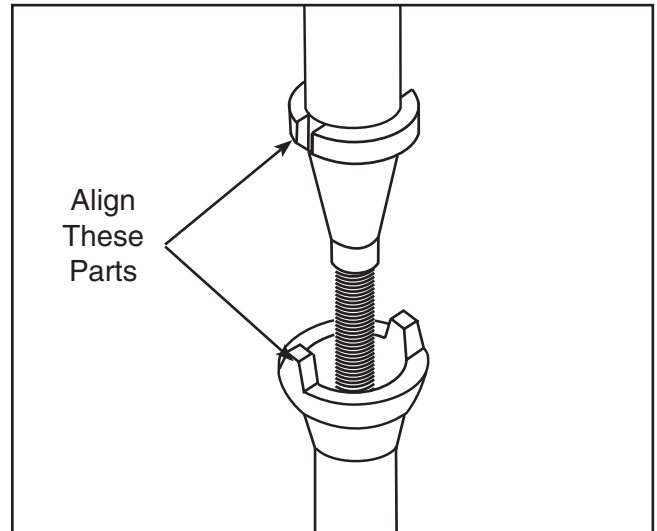

Figure 8. Installing spindle into the cartridge.

4. Thread the drawbar nut, tapered side up, onto the bottom of the drawbar, as illustrated in **Figure 9**.

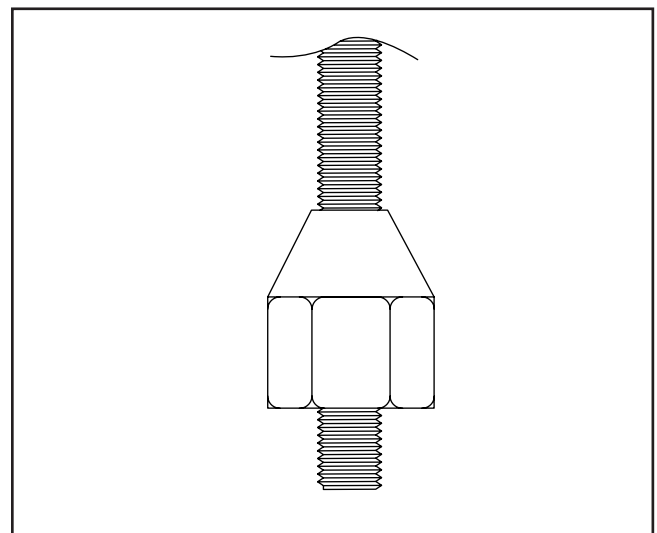

Figure 9. Drawbar nut on spindle.

5. Place the spindle wrench on top of the spindle, so it fits over the head of the spindle. Place a 15mm wrench on the drawbar nut.
6. Hold the spindle in place and tighten the drawbar nut. **DO NOT** use excessive force.



Handles

The guard adjuster is used to secure the guard to the table and allow the guard to be loosened for adjustment.

To assemble the guard adjuster:

1. Install the bar into the shaft guide as shown in **Figure 10**.
2. Line up the groove in the bar with the set-screw.



Figure 10. Bar into shaft guide.

3. Tighten the shaft setscrew into the groove to lock the bar in place as shown in **Figure 11**.



Figure 11. Tightening setscrew with hex key.

4. Install the round knobs shown in **Figure 12** onto both ends of the bar.



Figure 12. Round knobs onto bar.

The wheel shown in **Figure 13** fits on the adjustment shaft. This locks in place by tightening the setscrew into the groove on the shaft. There is a threaded hole on the wheel that allows for the optional installation of a crank (not included).

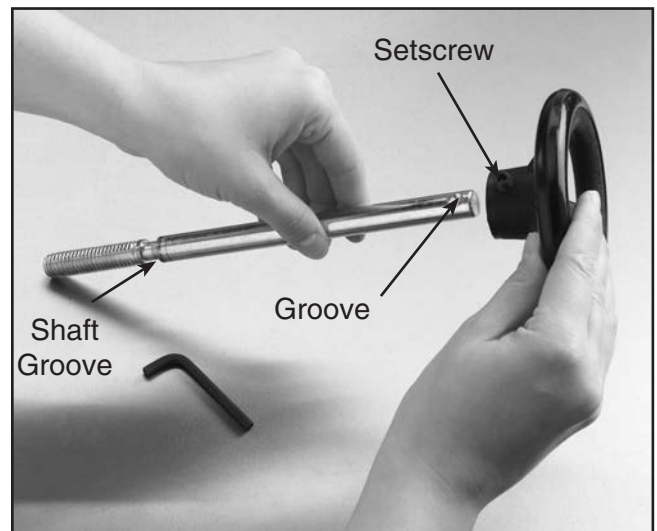

Figure 13. Wheel onto adjustment guide.



Cutter Guard

To mount the cutter guard to the table:

1. Place the guard over the threaded holes on the table.
2. Insert the shaft guide with a washer into the guard as shown in **Figure 14**, and thread the shaft guide clockwise to secure the guard to the table.

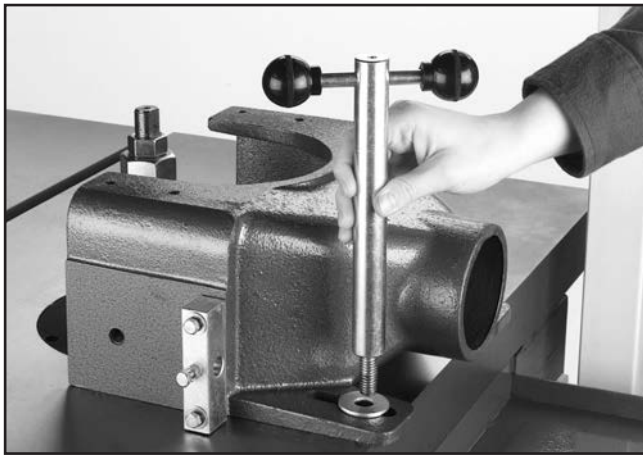

Figure 14. Inserting shaft guide into guard.

3. Insert the adjustment guide into the screw bracket. Line up the shaft groove shown in **Figure 13** with the center bolt and screw the bolt into the groove as shown in **Figure 15**. Do not completely tighten the bolt. This will allow the shaft to spin without coming out.



Figure 15. Tightening bolt into shaft groove.

Fence Assembly

To mount the fence brackets to the cutter guard:

1. Thread the adjustment shaft into the fence bracket as shown in **Figure 16**.

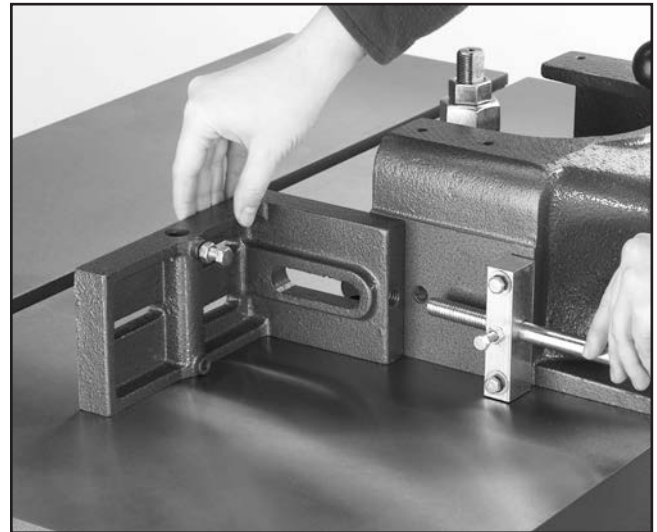

Figure 16. Adjustment guide to fence bracket.

2. Insert the adjustment handle (see **Figure 17**) into the fence bracket, and thread it into the cutter guard.

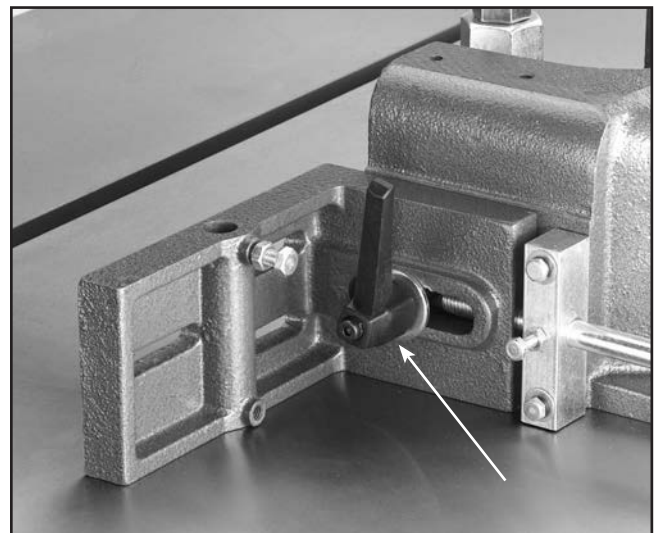

Figure 17. Adjustment handle.



To install the wood facing:

1. Secure the wooden fence pieces (as shown in **Figure 18**) with the $\frac{5}{16}$ "- 18 x 1" Phillips screws, washers, and hex nuts provided.
2. If using your own wood pieces, make sure the countersunk holes in your fence material are deep enough so the entire screw head is below the fence surface.

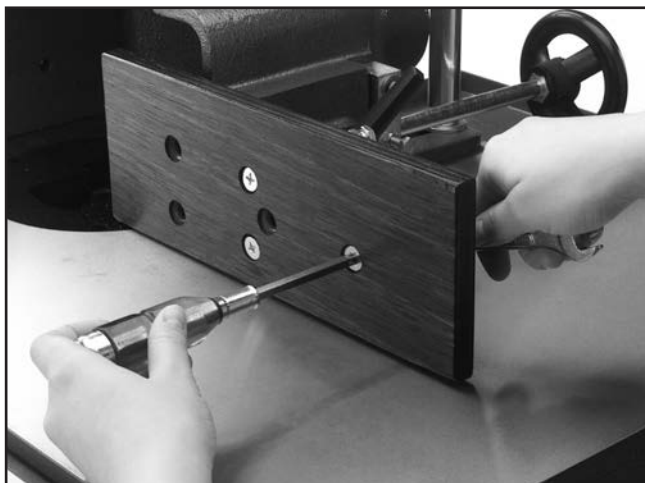

Figure 18. Attach wooden fence assembly.

Cutter Guard Cover

To mount the cutter guard cover:

1. Place the cutter guard cover over the threaded holes in the top of the cutter guard, as shown in **Figure 19**.
2. Thread the knobs into the cutter guard and secure the cover.

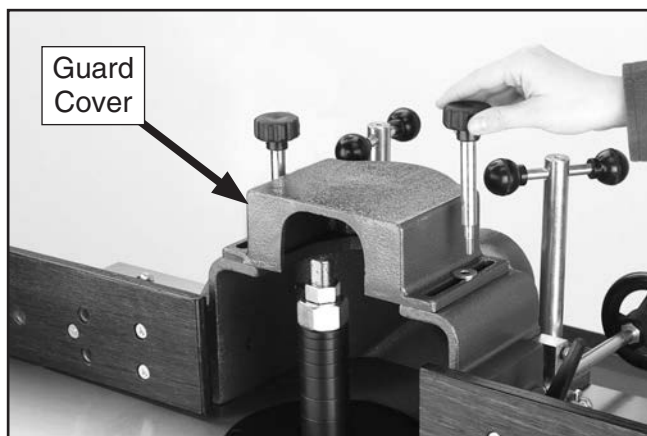

Figure 19. Installing the cutter guard cover.

Spindle Enclosure Guard

To attach the spindle enclosure guard:

1. Attach front guard extension plate to threaded holes on top of cutter guard cover with (2) $\frac{1}{4}$ "-20 x $\frac{1}{2}$ " knob bolts and (2) $\frac{1}{4}$ " flat washers (see **Figure 20**).
2. Attach front spindle enclosure guard to extension plate with (2) $\frac{1}{4}$ "-20 x $\frac{1}{2}$ " knob bolts and (2) $\frac{1}{4}$ " flat washers (see **Figure 20**).

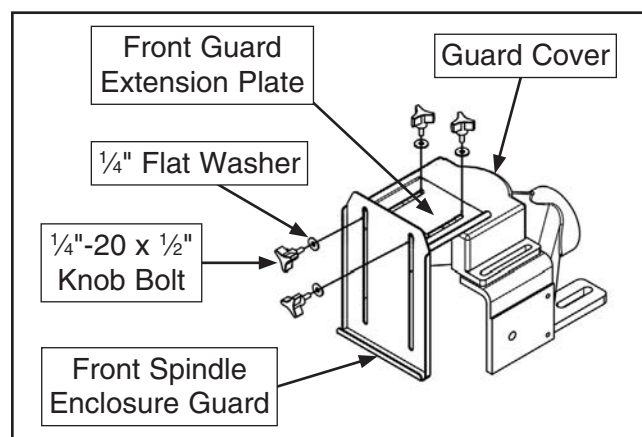

Figure 20. Front guard extension plate and spindle enclosure guard attached to guard cover.



Spindle Enclosure Guard Positioning

The spindle enclosure guard protects the user from exposure to the cutter and chips thrown by it. To minimize the risk of injury, the spindle enclosure guard must be adjusted so it encloses as much of the spindle area as possible, while still allowing the workpiece to pass through the cut. Typically this means the front guard is positioned to just clear the top of the workpiece.

To position the spindle enclosure guard, loosen the top knob bolts and slide the extension plate in or out, then loosen the front knob bolts and raise or lower the spindle enclosure guard as needed. Tighten the knob bolts to secure the setting.

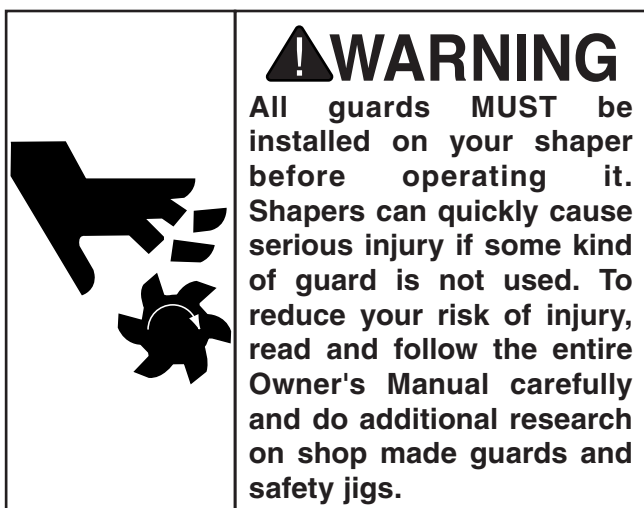

Handwheel Handle

Thread the crank handle onto the handwheel.



Figure 21. Handwheel mounted to shaper.

Hold-Downs

Hold-downs are used to hold the workpiece flat on the table and snug against the fence.

To assemble the hold-downs:

1. Slide a hold-down bar into each of the cast iron hold-down brackets (see **Figure 22**).

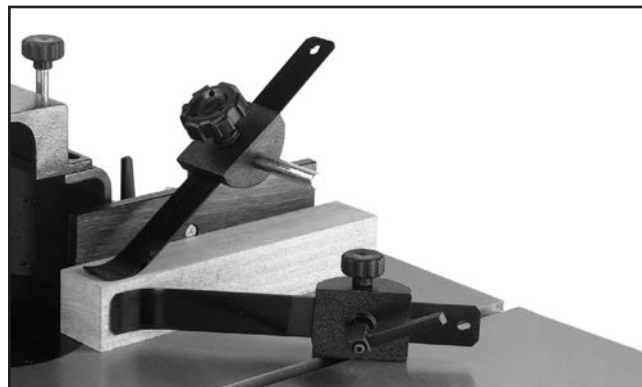

Figure 22. Example of hold-downs on workpiece.

2. Insert the bracket pole into the fence bracket and hold-down bracket.
3. Partially screw handle into hold-down brackets.
4. Slide two hold-down brackets into miter slot. Position so they are across from fence mounted hold-downs (see **Figure 23**). Tighten with the knob on top of each miter hold-down.

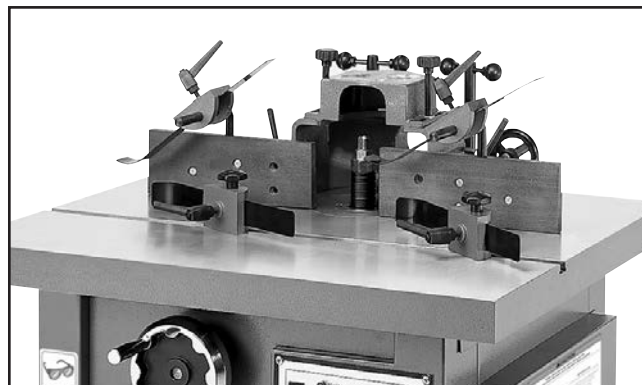
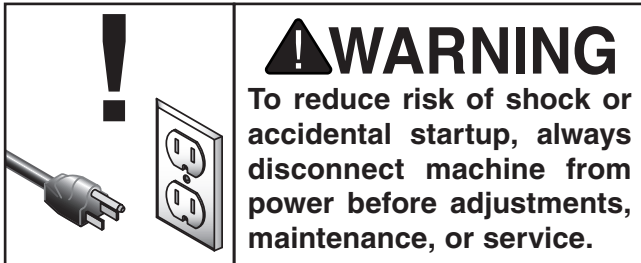

Figure 23. Overview of hold-downs in place.

5. Position the hold-downs according to the size of your workpiece.
6. Tighten the handles to secure the hold-downs.



SECTION 4: ADJUSTMENTS



Pulleys & V-Belt

Improper pulley alignment sharply reduces the effectiveness of power transmission and belt life expectancy.

To align the pulleys:

1. DISCONNECT SHAPER FROM POWER!
2. Remove the motor cover from the back of the shaper cabinet to expose the motor and pulleys.

3. Check the alignment with a straightedge. If the pulleys are in alignment, the straightedge should touch two sides of each pulley evenly as in **Figure 24**.

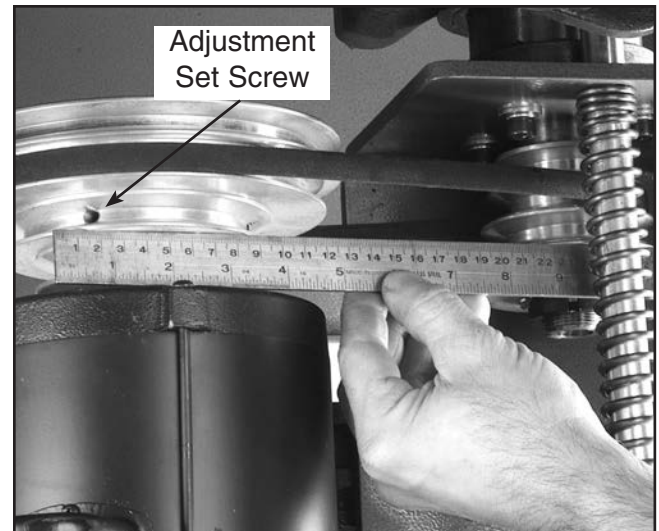

Figure 24. Inspecting pulley alignment.

4. If the pulleys are parallel with each other, but not in line, the motor needs to be adjusted.
5. This process is easiest with the help of another person. Loosen the four bolts that attach the motor to the motor base. One person should slide the motor either up or down while the other person measures the alignment of the motor pulley and the spindle pulley with a straightedge.
6. When the motor pulley and the spindle pulley alignment are correct, tighten the motor to the motor base.
7. Inspect your results. If satisfactory, double-check that the mounting bolts are tight.
8. You can also make small adjustments in the motor pulley alignment by raising or lowering it along the motor shaft. To do this, loosen the two set screws (one is shown in **Figure 24**) which are in the lowest groove of the motor pulley and move the pulley into position. Tighten the set screws when the alignment is satisfactory.



V-Belt Tension

You should be able to deflect the belt $\frac{1}{4}$ " with moderate finger pressure, as shown in **Figure 25**. This may seem tight compared to most other V-belts, but since the belt is small and runs fast, this amount of tension is necessary. The V-belt will slip if too loose, and will squeal or cause vibration if too tight. Adjust the tension if necessary.

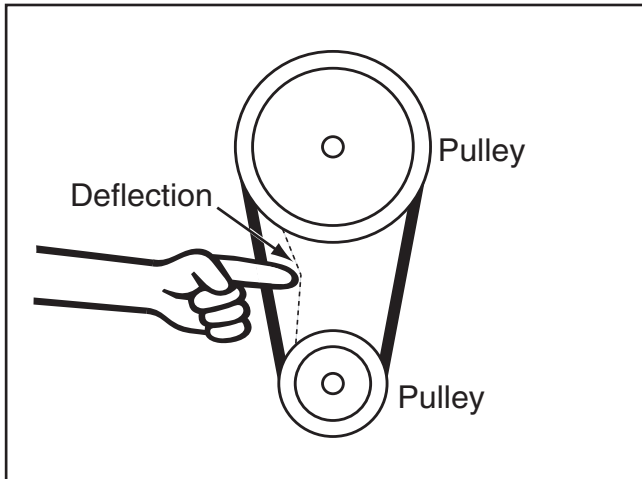
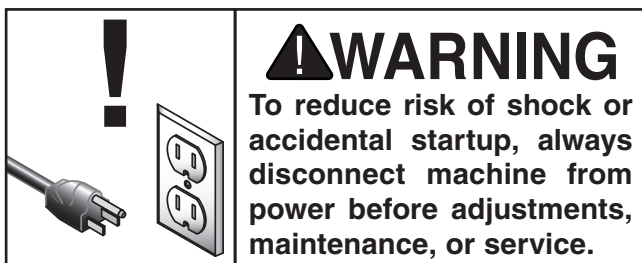

Figure 25. Checking belt deflection.

To adjust V-belt tension:

1. DISCONNECT SHAPER FROM POWER!
2. Make sure the pulleys are properly aligned.
3. Loosen the two motor mount plate bolts and slide the motor left or right to modify the belt tension. Keep the pulleys aligned.
4. Tighten the motor mount plate bolts, test the tension, and check the pulleys.
5. Repeat **steps 2-3** until tension is correct and the pulleys are aligned.



WARNING

To reduce risk of shock or accidental startup, always disconnect machine from power before adjustments, maintenance, or service.

Speed Changes

The Model G5912Z/G7214Z is equipped with a V-belt drive system that controls the speeds.

To change spindle speeds:

1. DISCONNECT SHAPER FROM POWER!
2. Loosen the two motor plate bolts, and slide the motor toward the spindle assembly. DO NOT take the bolts out.
3. Select the desired speed. There are four speeds: 3600 RPM, 5100 RPM, 8000 RPM, 10,000 RPM. **Figure 26** shows the belt positions for each available speed.

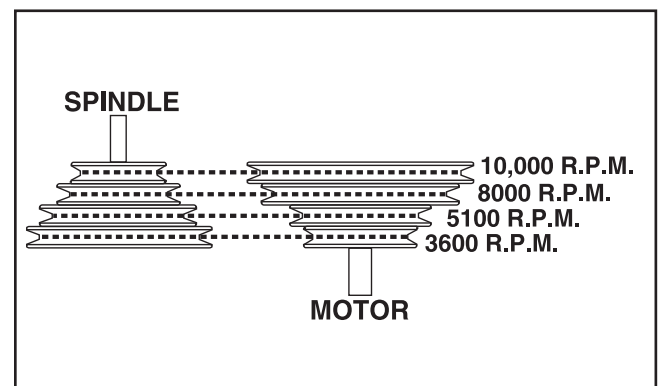

Figure 26. Spindle speed adjustment.

4. Align the belt along the appropriate pulley grooves.
5. Slide the motor back into position and tighten the belt. When the belt is properly tensioned, there should be approximately $\frac{1}{4}$ " of deflection in the center of the belt when you press it with moderate pressure.
6. Tighten all the adjusting bolts.
7. Spin the pulley to ensure proper tracking.



Fence Adjustment

The fence is a two-piece adjusting system. Each fence is independently adjustable to compensate for different cutting thicknesses and special shaping applications. Without any play, one turn of the knob moves the split fence approximately $\frac{5}{64}$ " (.078").

More detailed information concerning fence adjustments is covered in the "Straight Shaping" instructions.

To adjust the fence:

1. Loosen the fence lock handle.
2. Turn the fence adjustment knob until the fence is set to the desired position.
3. Tighten the fence lock handle.

Aligning Fences

To ensure that the fence is parallel with itself and square with the table:

1. Check that the bolts through the wood facing are tight on each side and adequately countersunk.
2. To align the wood facing, adjust one or both fence halves so they are in close alignment. Micro-adjust and check the alignment with a straightedge as shown in **Figure 27**.
3. If the wood fences are not parallel with each other, shim the incorrect side with shim washers. Normal washers may work, but shim washers allow for fine adjustments.



Figure 27. Aligning fences with straightedge.



Table Inserts

The Model G5912Z/G7214Z is supplied with two inserts which give you three possible opening diameters in the shaper table surface. Use the smallest opening that a particular cutter will allow. This offers more support for the workpiece and reduces the amount of chips that can fall into the machine. The correct spindle opening also allows any unused portion of the cutter to remain below the table surface—increasing operator protection.

The cast iron table insert must be flush with the top of the table.

To adjust the insert:

1. Remove the three Phillips® head screws that hold the cast iron insert in place.
2. Using a straightedge and a screwdriver, turn the barrel screws clockwise or counterclockwise to level the larger table insert with the table (**Figure 28**).



Figure 28. Leveling table insert.

3. Inspect the table insert with the straightedge from both side-to-side and front-to-back to ensure it is flush with the table. Replace and secure the Phillips head screws.

Test Run

Once assembly is complete and adjustments are done to your satisfaction, inspect the machine for loose nuts, bolts, tools or any unsafe condition. Correct as necessary, then connect the machine to the power source.

DO NOT have a cutter installed when you test run the shaper. Turn on the power supply at the main panel. Press the START button. Make sure that your finger is poised on the STOP button, just in case there is a problem. The shaper should run smoothly with little or no vibration or rubbing noises. Strange or unnatural noises should be investigated and corrected before operating the machine further.

If the shaper seems to be running correctly, check the directional switch. The spindle should be rotating in a counterclockwise direction when the switch is in the FORWARD position. Run the Model G5912Z/G7214Z for a short time to ensure that the moving parts are working properly with no excessive vibration. If any problem develops, correct it before attempting to use the machine.

If you cannot locate the source of unusual noises, immediately contact our service department for help.

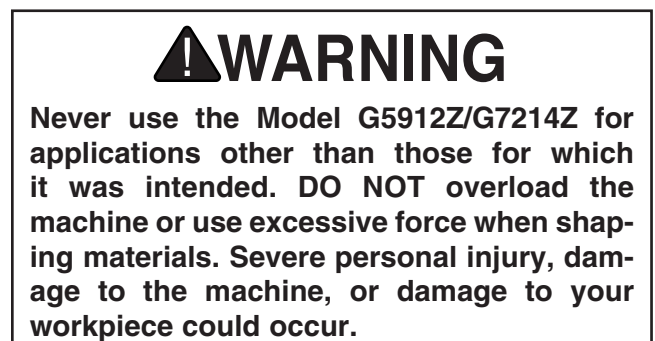
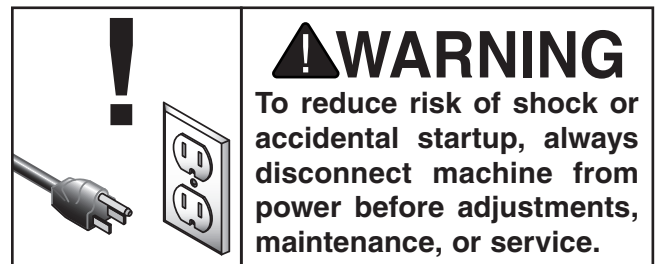

SECTION 5: OPERATIONS

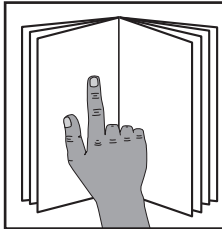

!WARNING

To reduce your risk of serious injury, read this entire manual **BEFORE** using machine.

!WARNING

Eye injuries, respiratory problems, or hearing loss can occur while operating this tool. Wear personal protective equipment to reduce your risk from these hazards.

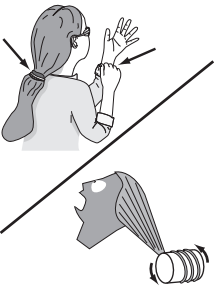
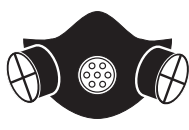

!WARNING

Keep hair, clothing, and jewelry away from moving parts at all times. Entanglement can result in death, amputation, or severe crushing injuries!

NOTICE

If you are not experienced with this type of machine, **WE STRONGLY RECOMMEND** that you seek additional training outside of this manual. Read books/magazines or get formal training before beginning any projects. Regardless of the content in this section, Grizzly Industrial will not be held liable for accidents caused by lack of training.

Rotation

Your shaper is equipped with a FORWARD/REVERSE switch as shown in **Figure 29**. In many instances, you will find it necessary to flip the cutter over and reverse cutter rotation. Whenever possible, mount the cutter so the board is milled on the bottom side. This method does a better job and is safer for the operator.

!CAUTION

Always check the direction of cutter rotation before beginning any shaping operation.



Figure 29. FORWARD/REVERSE switch.

NOTICE

This machine was designed to be started and stopped with the **START/STOP** buttons—not the reversing switch.



Cutter Installation

Your shaper operates at speeds of 3600, 5100, 8000 and 10,000 R.P.M. 3½" or larger cutters must be operated at the slowest speed.

Always use the largest spindle size possible, and never use more than one bushing size to gain two spindle sizes. "Stacking" two cutter bushings to decrease the inside diameter of the cutter and will cause the cutter to perform incorrectly when placed under a load.

To install a cutter:

1. DISCONNECT SHAPER FROM POWER!
2. Place an appropriate spacer or collar at the base of the spindle for support.
3. Place the cutter on the spindle. Make sure the rotation is correct for your application.
4. Use spacers or collars to suit your particular application.
5. Place the spindle washer under the nut. Screw on the nut and locknut.
6. Tighten the nuts while holding the spindle stationary. Use a wrench on the notches at the top of the spindle for leverage as shown in **Figure 30**.



Figure 30. Tightening spindle nuts.

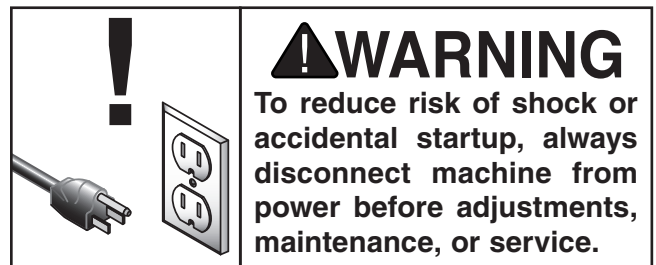

!WARNING

To reduce risk of shock or accidental startup, always disconnect machine from power before adjustments, maintenance, or service.

!WARNING

Always use a spindle lock nut during operation. If this warning is ignored, the cutter may fly off the spindle during use and cause severe personal injury.



Spindle Height

To adjust the cutter height:

1. Loosen the spindle lock shown in **Figure 31**.
2. Move the spindle up or down with the handwheel until the desired position is obtained.
3. Lock the spindle into position.

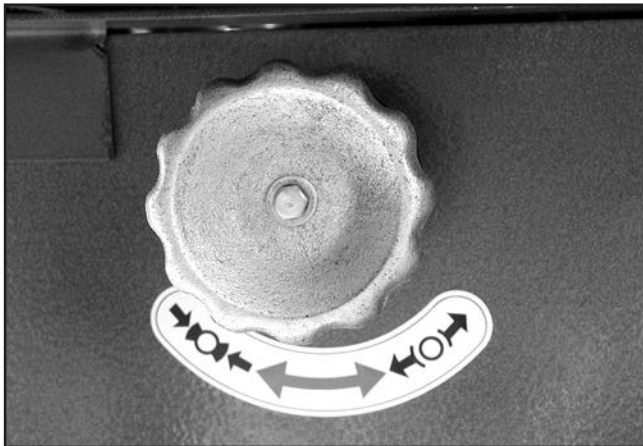
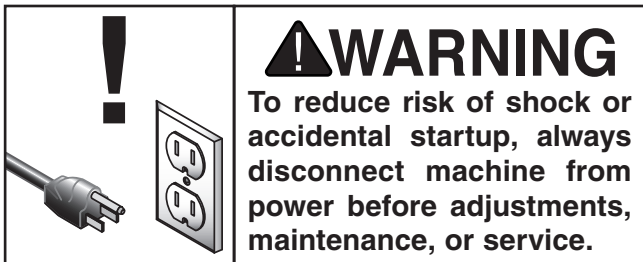

Figure 31. Location of spindle lock.



NOTICE

The lock knob keeps the spindle in a fixed position during shaper operation. Do not over-tighten the lock knob. A snug fit is all that is needed to keep the spindle from moving during shaper use.

Straight Shaping



The fence assembly is a two-piece, independently adjustable system. When removing material from the whole face of your workpiece, the outfeed fence can be adjusted to provide support for the workpiece as it passes over the cutter. The outfeed fence can also be set in-line for partial face removal.

If removing material from the whole face, observe the following steps:

1. Loosen the locking handles shown in **Figure 32** that hold the fences in place.

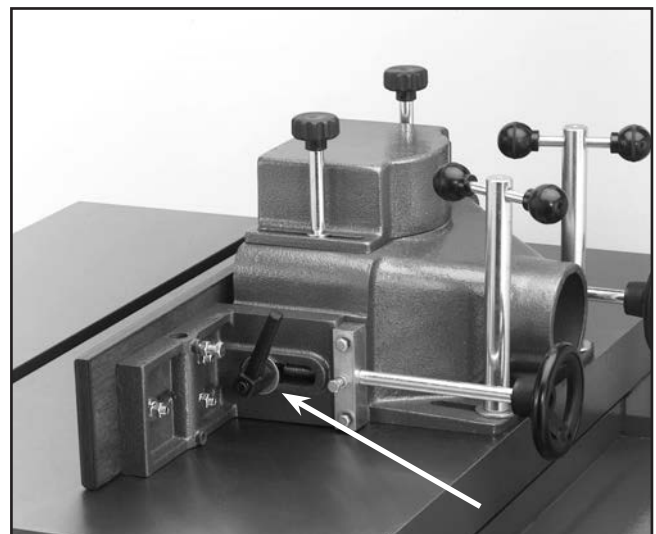

Figure 32. Location of fence locking handles.

2. Adjust the infeed fence by turning the adjustment knobs until the workpiece contacts the cutter in the desired location.
3. Lock the infeed fence in position with the locking handle. Use a test piece to determine the best setting.



4. Loosen the mounting screws on the fence faces and set the face ends to barely clear the cutter. This allows the maximum support possible for the workpiece while passing the cutter. Remember to tighten the wood facing before starting the shaper.
5. A test sample of the desired cut should be advanced about 8" then stopped.
6. Once the shaper is turned off and the cutter has come to a complete stop, adjust the outfeed fence to support the new profiled edge (see **Figure 33**).

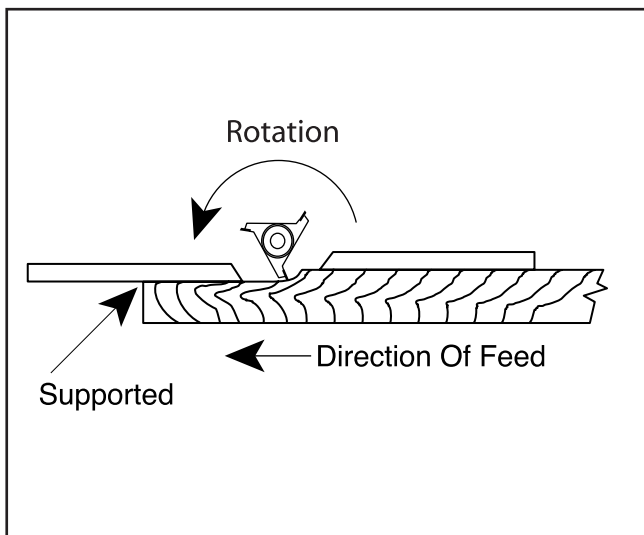

Figure 33. Fence adjusted to support workpiece.

If the face of the workpiece will only be partially removed, observe the following steps:

1. Adjust the infeed fence to approximately the desired depth of cut. Lock the infeed fence in place.
2. Use a straightedge to adjust the outfeed fence to the same plane as the infeed fence. Lock the outfeed fence in place.
3. Set the right and left wood faces so the ends barely clear the cutter. This allows the maximum support possible for the workpiece while passing the cutter. Remember to tighten down the wood facing before starting the shaper.

4. Run a test piece through the shaper as shown in **Figure 34**.

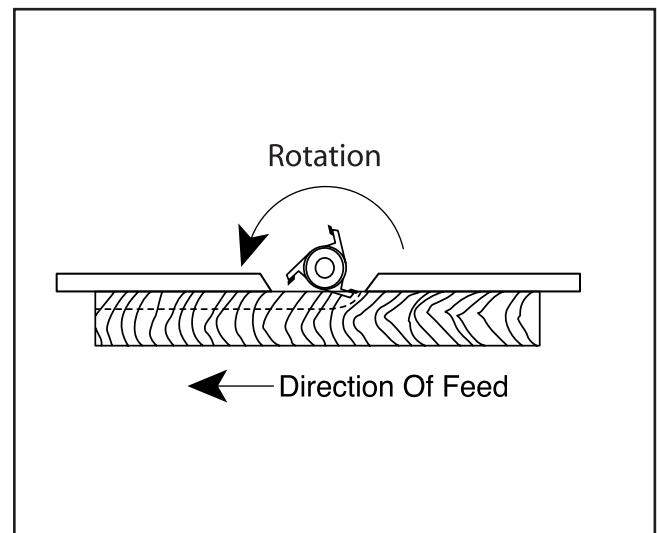

Figure 34. Fence adjustment for blind cuts.

5. Always cut the end grain first when putting an edge around the perimeter of your workpiece (see **Figure 35**).

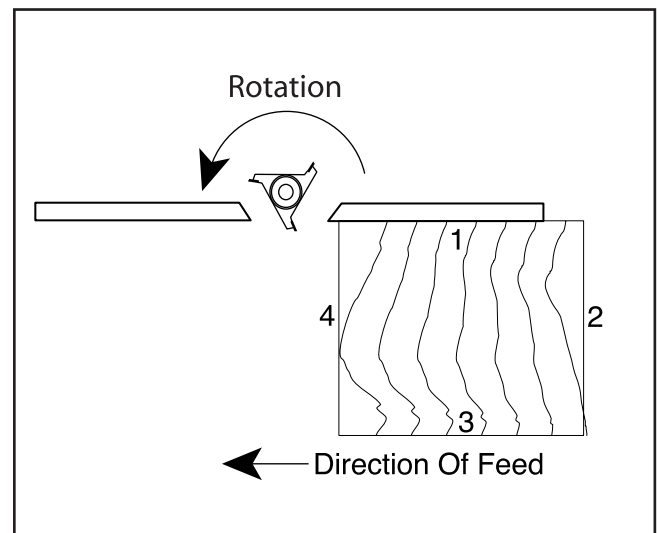

Figure 35. Fence adjustment for multiple cuts.



Rub Collars

Rub collars are used when shaping curved or irregular workpieces, such as arched doors or round table tops. Rub collars also limit the depth of your cut.

There are two types of rub collars—solid and ball-bearing. We recommend against the use of solid rub collars. Grizzly carries an extensive line of ball bearing rub collars designed for use with Grizzly shapers. See the current catalog for listings.

Rub collars may be used in any of the following positions:

1. **Rub collar below the cutter:** When the rub collar is used below the cutter as shown in **Figure 36**, the progress of the cut can be observed. However, any unintentional movement may lift the workpiece into the cutter, damaging your work and creating a dangerous situation. We DO NOT recommend this type of setup!

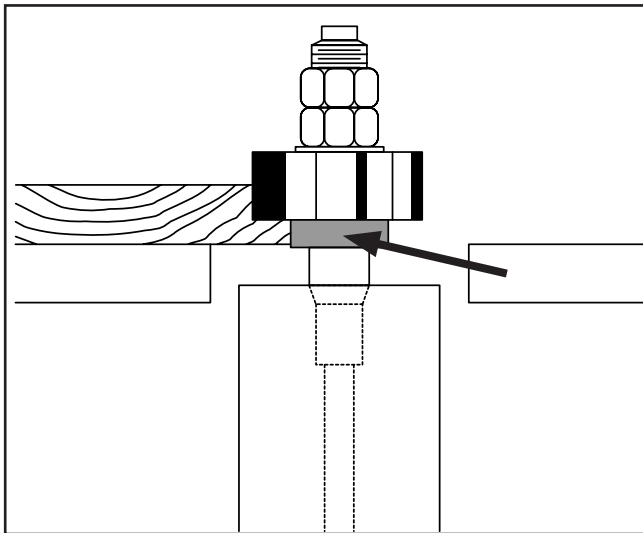

Figure 36. Rub collar installed below cutter.

⚠ CAUTION

Whenever the cutterhead is above the workpiece, or you can see cutterhead spinning during use, you must take extreme caution to keep your hands away from the cutterhead. Failure to do so may cause serious personal injury.

2. **Above the cutter:** When the rub collar is used above the cutter as seen in **Figure 37**, the cut cannot be seen. This offers some advantage: the stock is not affected by slight variations in thickness and accidental lifting will not damage the workpiece. If lifting occurs, simply correct the mistake by repeating the operation.

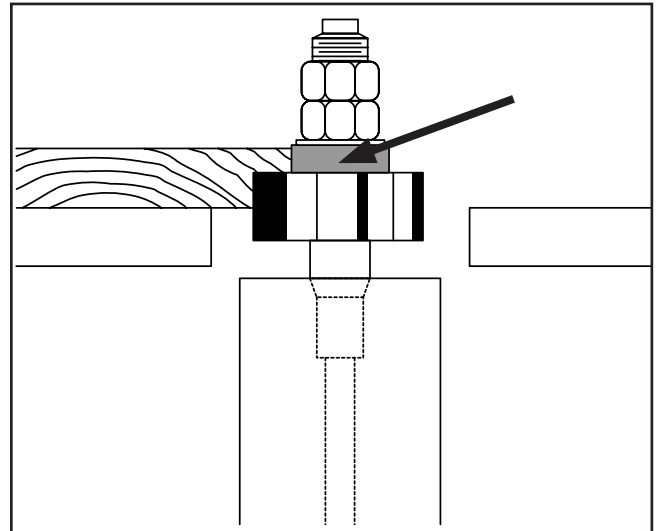

Figure 37. Rub collar installed above cutter.

3. **Between two cutters:** Using a rub collar between two cutters, as in **Figure 38**, has the distinct advantage of performing two cuts at once or eliminating the need to change cutters for two different operations. Notice that part of the edge is left uncut. The uncut portion rides on the rub collar.

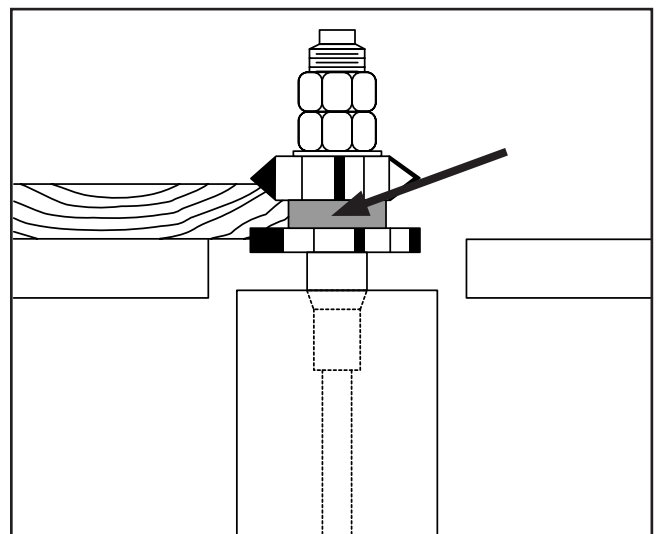

Figure 38. Rub collar between two cutters.



Pattern Work

When using a pattern, the rub collar can be positioned either above, below or between cutters.

The pattern is usually used when the entire edge is to be shaped or when many duplicate pieces are needed. Pattern work is particularly useful when rough cutting irregular or oversize pieces and then shaping the edge in a simple two-step operation. A pattern can be incorporated into a jig by way of adding toggle clamps, hand holds or other safety devices.

You have greater flexibility when choosing the correct diameter rub collar for pattern work than for non-pattern work. If you look at **Figure 39**, you will notice that the position of the pattern determines the depth of cut. In other words, your pattern size is dependent upon the interrelationship of the cutting circle, the desired amount of material removed, and the rub collar size. Changing one or more of these will change the amount of material removed. Planning ahead, you can most effectively decide which rub collars are best suited for your application.

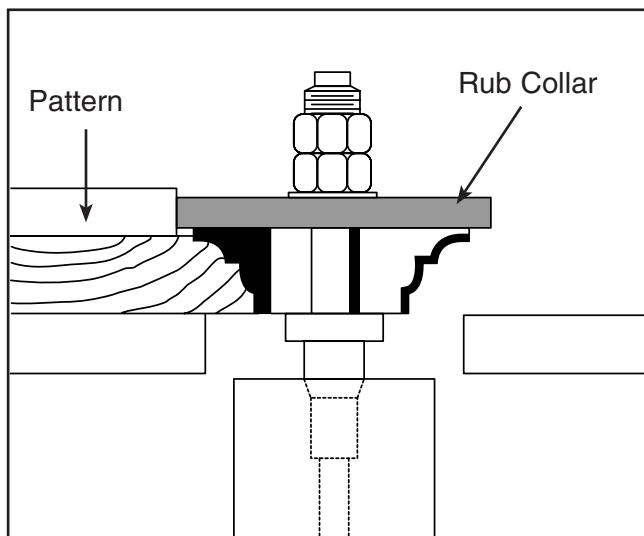

Figure 39. Rub collar determines depth of cut.

When making a pattern jig here are a few things to consider:

1. Build your jig from a material that will smoothly follow the rub collar or fence.

2. Make the jig stable, using proven methods and materials, and fasten the hand holds for operator comfort and safety.
3. Secure your workpiece on the three sides that will not be cut with toggle clamps, or fasten the workpiece to the jig with wood screws.
4. Ensure that clamps and hidden screws do not come into contact with the cutter.
5. Design your jig so that all cutting occurs underneath the workpiece as shown in **Figure 40**. Notice the operator is not exposed to the cutting edge of the cutter!
6. Always consider the cutting circle and rub collar diameter for the correct cutting depth when designing your pattern.
7. Make sure the workpiece rests flat on the table, not on the fixture.

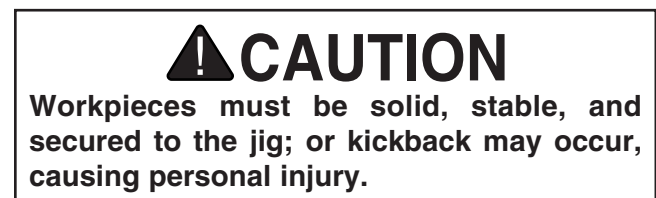

Figure 40. Pattern jig for making curved pieces.

Irregular or freehand shaping takes a high degree of skill and dexterity. The fence assembly is not used during irregular shaping, so rub collars must be used. Also, unless your jig is designed to touch the rub collar before contacting the blade, a starting fixture **MUST** be used to begin your cut.



Starting Fixures

The purpose of the starting fixture is to support the workpiece during the beginning of the cut. The workpiece is typically placed in the starting position using the starting fixture for support, then swung into the cutter while holding the workpiece firmly against the starting fixture. After the cut has been started, the work is swung away from the starting fixture and is supported only by the rub collar. **Always feed against the rotation of the cutter and do not start cuts at corners.**

To use your pattern jig:

1. Remove the fence assembly. Choose the appropriate cutter and rub collar for your application and lock them in place. Secure your workpiece to the pattern jig.
2. Check cutter rotation, and adjust the spindle height to align the cutter to your workpiece. Clamp a starting fixture to the table surface, using the location that best supports your work.
3. If everything is correct and the cutter is tight, turn the shaper **ON**.
4. Place your jig/workpiece against the starting fixture. Using firm pressure, pivot the workpiece into the cutter and make sure the jig is touching the rub collar. Keep your jig in contact with the rub collar and slowly follow the pattern, moving against the cutter rotation.

Freehand Shaping

Freehand methods are one of the most dangerous operations performed on a shaper. Although this machine is capable of performing freehand operations, we do not recommend that you attempt to do so. If you **MUST** perform freehand operations, get formal training and read a book that details freehand operations, their inherent dangers, and ways to avoid those dangers!

Shop Made Shaper Accessories

There are many accessories that can be built or purchased to increase operator. Many experienced shaper users regularly use proven shop-made fences and safety guards to augment their shaping operations. In addition, many production shops routinely use power feeders with their shapers to streamline their operations.

Here are some basic accessories and their uses:

- **Zero Clearance Fence**—A shop-made fence with an opening only as large as the cutter, so that only the part of the cutter being used is exposed.
- **Box Fence**—A shop-made box that completely surrounds the cutter. A one-piece fence is attached that allows only the thickness of the board to pass underneath, thereby completely shielding the operator from exposure to the spinning cutter. A clear plexiglass window on top of the box allows the operator to view the workpiece during cutting.

Because of the wide range of fences and guards that can be built in the shop, explaining their construction is beyond the scope of this manual. We strongly recommend that you read shaper books, trade magazines, or get formal training to learn more about these.



SECTION 6: ACCESSORIES

! WARNING

Installing unapproved accessories may cause machine to malfunction, resulting in serious personal injury or machine damage. To reduce this risk, only install accessories recommended for this machine by Grizzly.

NOTICE

Refer to our website or latest catalog for additional recommended accessories.

W1124—Rub Collar 1¼" x 2¼" OD

W1125—Rub Collar 1¼" x 2½" OD

W1126—Rub Collar 1¼" x 2¾" OD

W1127—Rub Collar 1¼" x 3" OD

W1128—Rub Collar 1¼" x 3¼" OD

W1129—Rub Collar 1¼" x 3⅜" OD

W1130—Rub Collar 1¼" x 3½" OD

W1131—Rub Collar 1¼" x 4" OD

If you do any kind of irregular shaping, these ball bearing collars are a must! Rub collars are used for shaping curved work such as cathedral doors as well as many custom shapes. They are also used for limiting the depth of cut (same principle as router bits with guide bearings). Use them below, in between, or above cutters.



Figure 41. Assorted rub collars.

G3030—Shaper Handbook

Roger Cliffe and Michael Holtz show you the potential of your shaper. Hundreds of techniques are explored in vivid detail and clear step-by-step instructions. There are tips on freehand shaping as well as jig and fixture shaping. 256 pages.

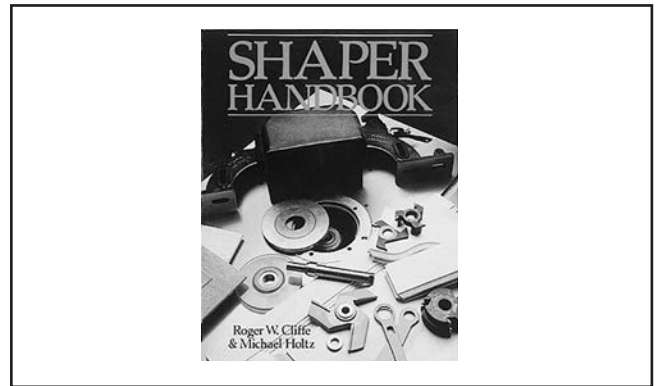

Figure 42. G3030 Shaper Handbook.

H2499—Small Half-Mask Respirator

H3631—Medium Half-Mask Respirator

H3632—Large Half-Mask Respirator

H3635—Cartridge Filter Pair P100

Wood dust has been linked to nasal cancer and severe respiratory illnesses. If you work around-dust everyday, a half-mask respirator can be a lifesaver. Also compatible with safety glasses!



Figure 43. Half-mask respirator with disposable cartridge filters.

order online at www.grizzly.com or call 1-800-523-4777



Basic Eye Protection

T20501—Face Shield Crown Protector 4"

T20502—Face Shield Crown Protector 7"

T20503—Face Shield Window

T20451—"Kirova" Clear Safety Glasses

T20452—"Kirova" Anti-Reflective S. Glasses

T20456—DAKURA Safety Glasses, Black/Clear



Figure 44. Assortment of basic eye protection.

D2271—Shop Fox® Roller Table

Use these versatile roller tables wherever you need extra workpiece support. Features all-steel welded construction and measures 19" x 65" long. Comes with 9 ball bearing rollers and has four independently adjustable legs for any leveling requirement. Adjustable in height from 26³/₈" to 44¹/₈". Approximate shipping weight: 62 lbs. 1000 lb. Capacity!



Figure 45. D2271 Shop Fox® Roller Table.

T10460—11¹/₂" Panel Shaping Jig

T10462—16" Panel Shaping Jig

T10464—24" Panel Shaping Jig

Make raised panel doors on your shaper safely and efficiently with these Panel Shaping Jigs. Twin pneumatic clamps lock the workpiece in-place, a cushion of air eliminates table friction for effortless control, and double switch valves keep both hands safely away from dangerous cutters while shaping.

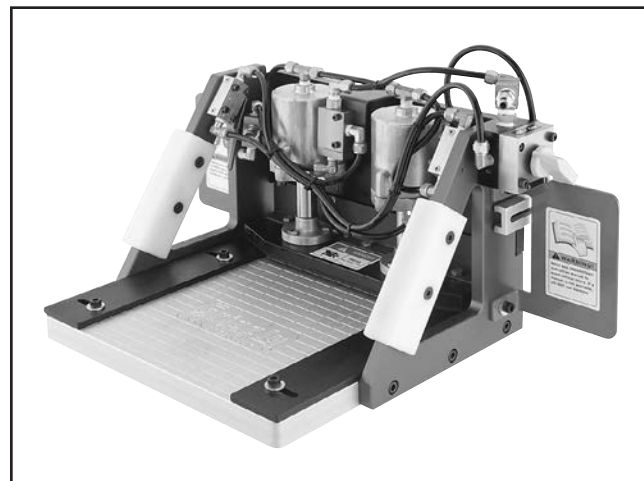

Figure 46. T10460 Panel Shaping Jig.

G4181—1 HP Power Feeder, Single-Phase

G7873—1 HP Power Feeder, 3-Phase

If you do any kind of production ripping or milling, you know what a big chore it can be feeding by hand, especially with longer and wider stock. For those of you who want to increase production, upgrade or add on an extra stock feeder, we have a power feeder that will match virtually any application and budget.

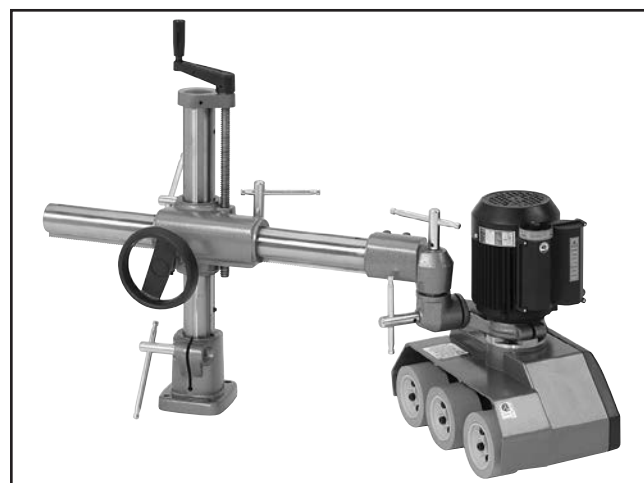
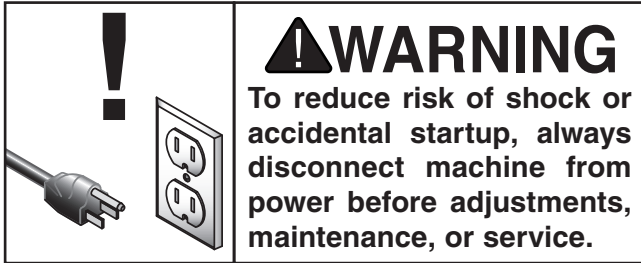

Figure 47. G4181 Power Feeder.

order online at www.grizzly.com or call 1-800-523-4777



SECTION 7: MAINTENANCE



Schedule

For optimum performance from this machine, this maintenance schedule must be strictly followed.

Ongoing

To maintain a low risk of injury and proper machine operation, if you ever observe any of the items below, shut down the machine immediately and fix the problem before continuing operations:

Daily Check:

- Loose mounting bolts.
- Damaged spindle.
- Worn or damaged wires.
- Apply anti-rust protection to table.
- Any other unsafe condition.

Weekly Maintenance

- V-belt tension, damage, or wear.
- Clean/vacuum dust buildup from inside cabinet and off motor.

Monthly Check

- V-belt tension, damage, or wear.
- Lubricate worm gears, elevation slide, and quill.

Cleaning

Vacuum excess wood chips and sawdust, and wipe off the remaining dust with a dry cloth. If any resin has built up, use a resin dissolving cleaner to remove it.

Unpainted Cast Iron

Protect the unpainted cast iron surfaces on the table by wiping the table clean after every use—this will ensure that moisture from wood dust will not remain on bare metal surfaces.

To avoid rust, do not use water or water-based products on the unpainted cast iron surfaces.

Keep tables rust-free with regular applications of products like G96® Gun Treatment, SLIPIT®, or Boeshield® T-9.

V-Belt

Avoid getting grease or oil on the V-belt or pulleys. Check the V-belt, as part of a monthly inspection for proper tension and belt condition. Cracking and glazing could result in belt failure. Replace the belt if such conditions appear.



SECTION 8: WIRING

These pages are current at the time of printing. However, in the spirit of improvement, we may make changes to the electrical systems of future machines. Compare the manufacture date of your machine to the one stated in this manual, and study this section carefully.

If there are differences between your machine and what is shown in this section, call Technical Support at (570) 546-9663 for assistance BEFORE making any changes to the wiring on your machine. An updated wiring diagram may be available. **Note:** *Please gather the serial number and manufacture date of your machine before calling. This information can be found on the main machine label.*

WARNING

Wiring Safety Instructions

SHOCK HAZARD. Working on wiring that is connected to a power source is extremely dangerous. Touching electrified parts will result in personal injury including but not limited to severe burns, electrocution, or death. Disconnect the power from the machine before servicing electrical components!

MODIFICATIONS. Modifying the wiring beyond what is shown in the diagram may lead to unpredictable results, including serious injury or fire. This includes the installation of unapproved after-market parts.

WIRE CONNECTIONS. All connections must be tight to prevent wires from loosening during machine operation. Double-check all wires disconnected or connected during any wiring task to ensure tight connections.

CIRCUIT REQUIREMENTS. You MUST follow the requirements at the beginning of this manual when connecting your machine to a power source.

WIRE/COMPONENT DAMAGE. Damaged wires or components increase the risk of serious personal injury, fire, or machine damage. If you notice that any wires or components are damaged while performing a wiring task, replace those wires or components.

MOTOR WIRING. The motor wiring shown in these diagrams is current at the time of printing but may not match your machine. If you find this to be the case, use the wiring diagram inside the motor junction box.















CAPACITORS/INVERTERS. Some capacitors and power inverters store an electrical charge for up to 10 minutes after being disconnected from the power source. To reduce the risk of being shocked, wait at least this long before working on capacitors.

EXPERIENCING DIFFICULTIES. If you are experiencing difficulties understanding the information included in this section, contact our Technical Support at (570) 546-9663.

NOTICE

The photos and diagrams included in this section are best viewed in color. You can view these pages in color at www.grizzly.com.

COLOR KEY

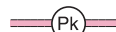
BLACK 	BLUE 	YELLOW 	LIGHT BLUE 
WHITE 	BROWN 	YELLOW GREEN 	BLUE WHITE 
GREEN 	GRAY 	PURPLE 	TURQUOISE 
RED 	ORANGE 	PINK 	



G5912Z Wiring Diagram

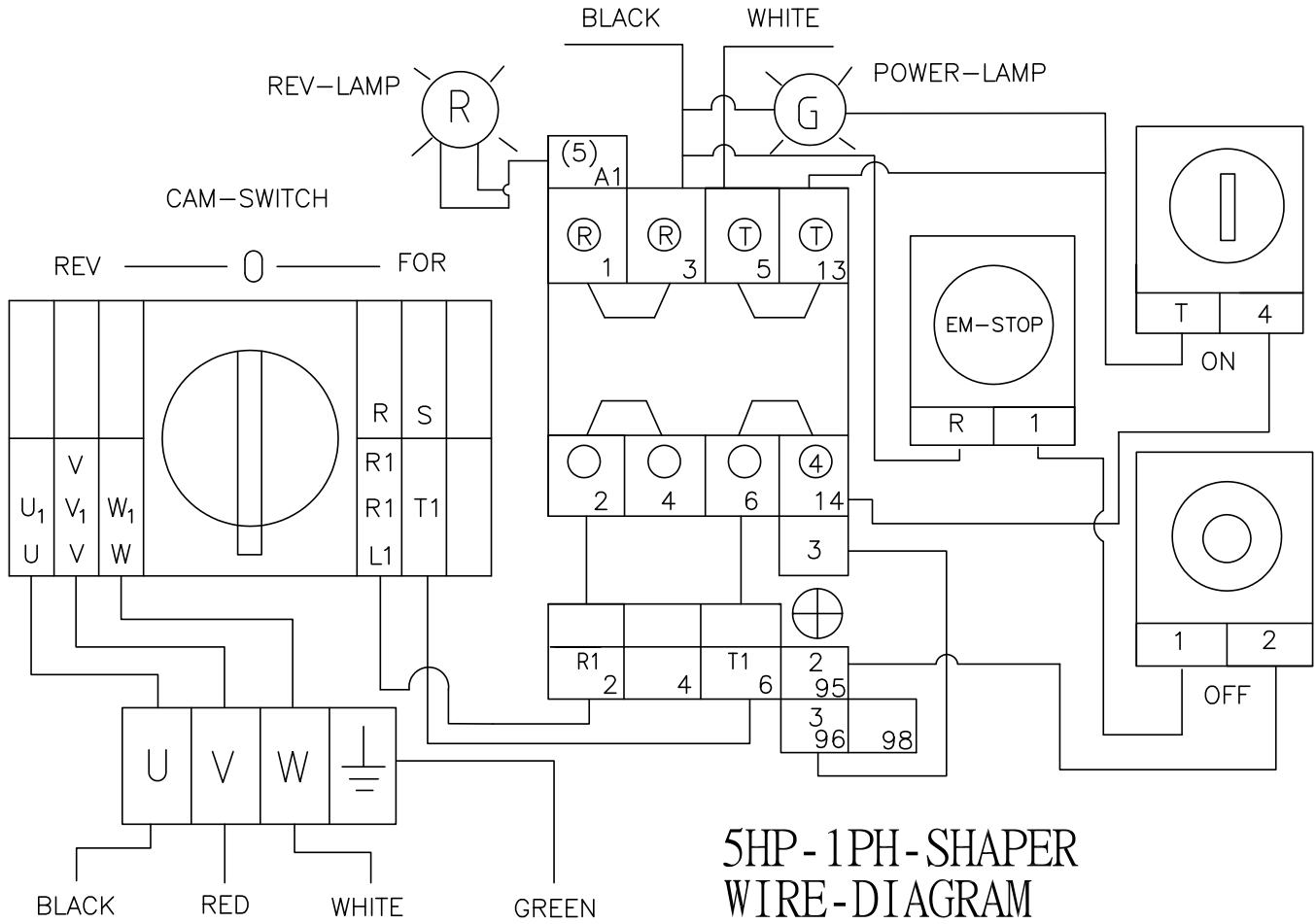

G7214Z Wiring Diagram

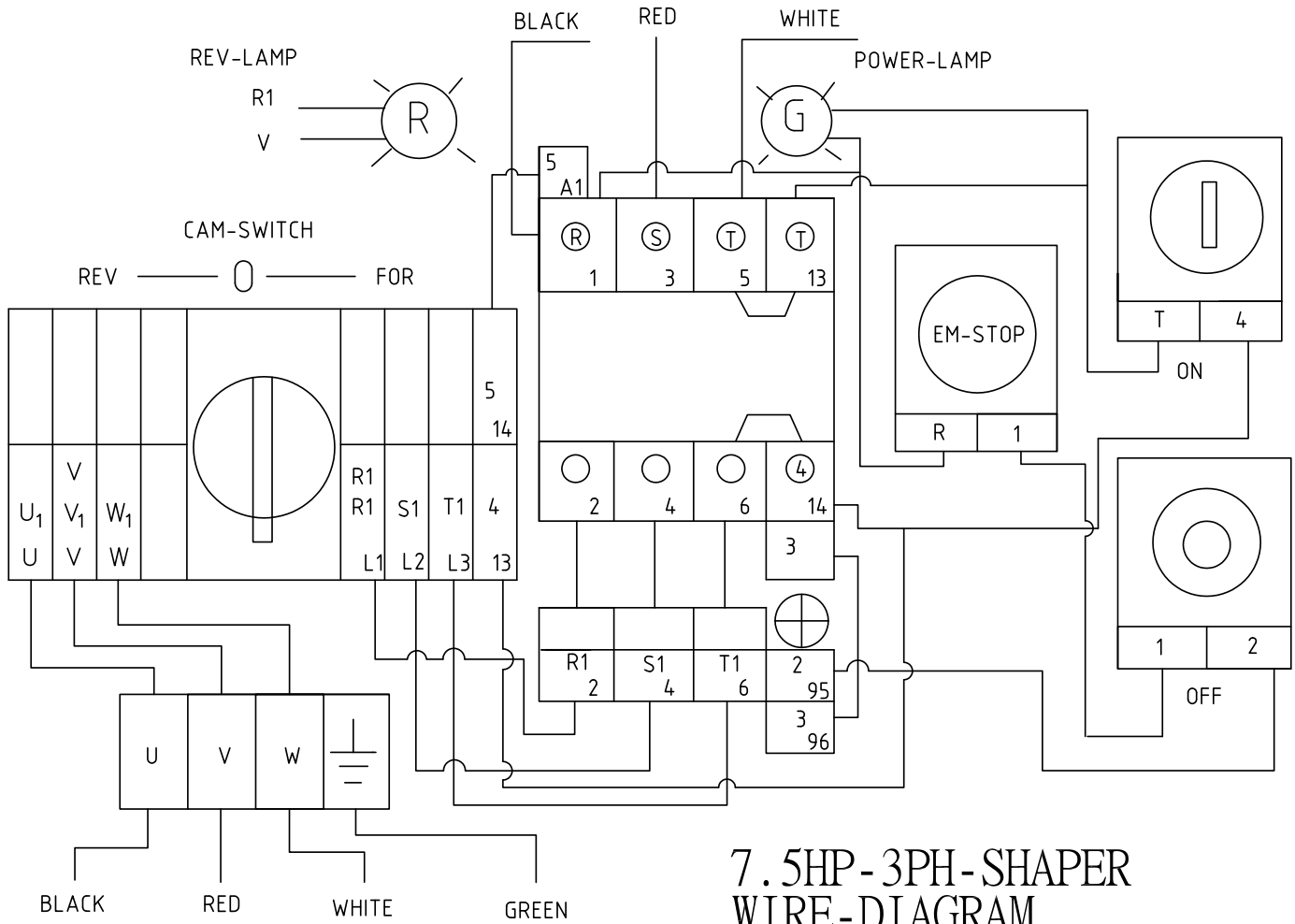

SECTION 9: PARTS

We do our best to stock replacement parts when possible, but we cannot guarantee that all parts shown are available for purchase. Call (800) 523-4777 or visit www.grizzly.com/parts to check for availability.

Cabinet

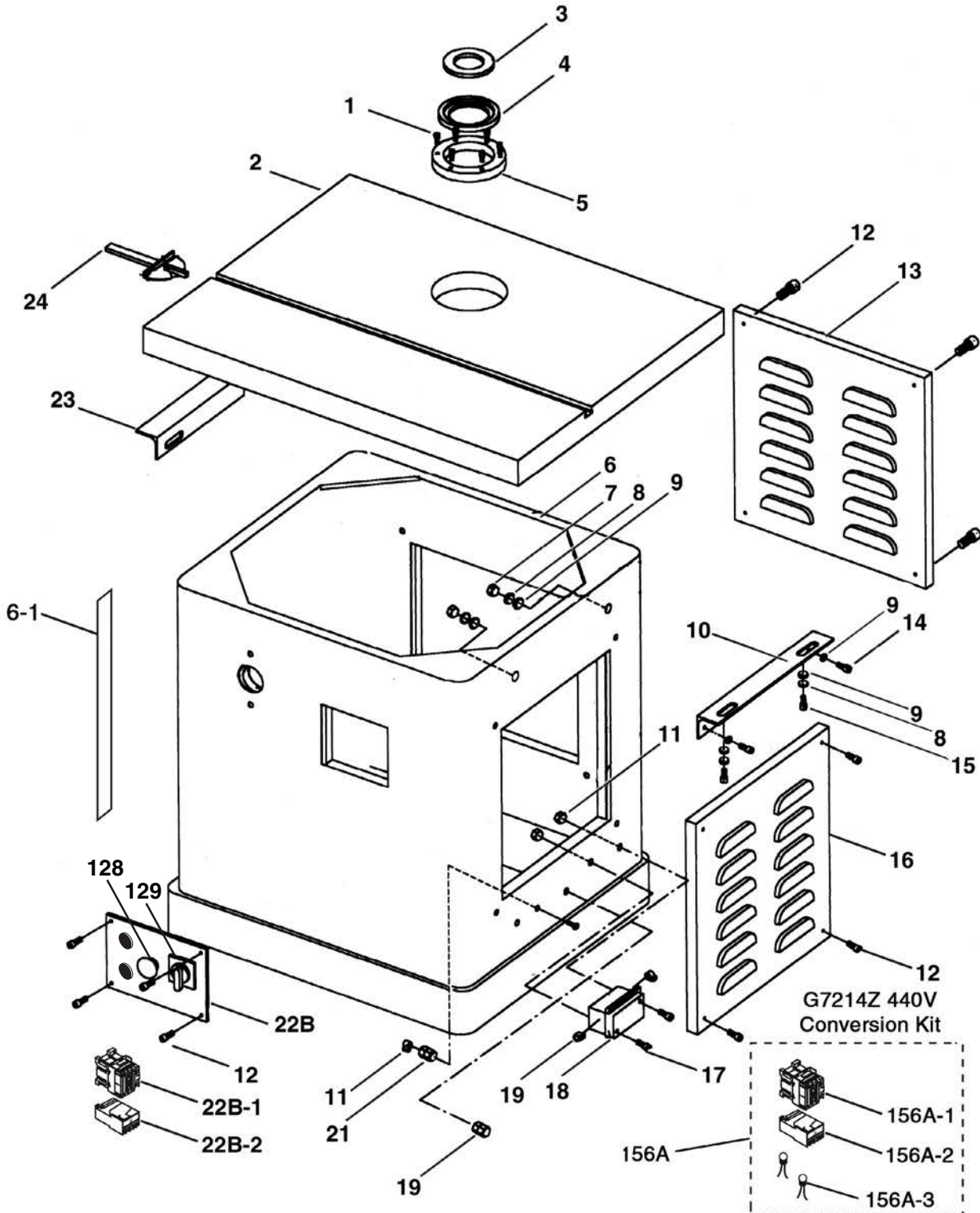

Cabinet Parts List

REF	PART #	DESCRIPTION
1	P5912Z001	SET SCREW 5/16-18 X 5/8
2	P5912Z002	TABLE
3	P5912Z003	INSERT (SMALL) INNER
4	P5912Z004	INSERT (MID)
5	P5912Z005	INSERT (BIG)
6	P5912Z006	STAND ASSY
6-1	P5912Z006-1	DEGREE SCALE
7	P5912Z007	HEX NUT 3/8-16
8	P5912Z008	LOCK WASHER 3/8
9	P5912Z009	FLAT WASHER 3/8
10	P5912Z010	TABLE BRACE (R)
11	P5912Z011	HEX NUT 10-24
12	P5912Z012	PHLP HD SCR 1/4-20 x 5/8
13	P5912Z013	REMOVABLE DUST DOOR
14	P5912Z014	HEX BOLT 3/8-16 X 1-1/4
15	P5912Z015	HEX BOLT 3/8-16 X 3/4
16	P5912Z016	MOTOR COVER
17	P5912Z017	PHLP HD SCR 10-24 X 3/4

REF	PART #	DESCRIPTION
18	P5912Z018	TERMINAL BOX ASSY
18A	P5912Z018A	TERMINAL BOX W/O BUSBAR
19	P5912Z019	STRAIN RELIEF M14.5 TYPE-6 ST
21	P5912Z021	STRAIN RELIEF 5/8" TYPE-9 ELBOW
22B	P5912Z022B	CONTROL PANEL ASSY (G5912Z)
22B-1	P5912Z022B-1	CONTACTOR (G5912Z)
22B-2	P5912Z022B-2	OVERLOAD RELAY (G5912Z)
22B	P7214Z022B	ELECTRICAL BOX ASSY (G7214Z)
22B-1	P7214Z022B-1	CONTACTOR (G7214Z)
22B-2	P7214Z022B-2	OVERLOAD RELAY (G7214Z)
23	P5912Z023	TABLE BRACE (L)
24	P5912Z024	MITER GAUGE
128	P5912Z128	E-STOP SWITCH
129	P5912Z129	F/O/R SWITCH KEDUZH-HC-33-BY
156A	P7214Z156A	CONVERSION KIT 440V NHD V2.01.06
156A-1	P7214Z156A-1	MAGNETIC CONTACTOR 440V NHD V2.01.06
156A-2	P7214Z156A-2	THERMAL PROTECTOR 440V HND V2.01.06
156A-3	P7214Z156A-3	LIGHT BULB 440V V2.01.06



Spindle

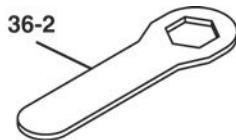
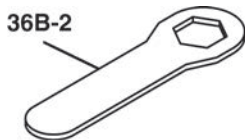
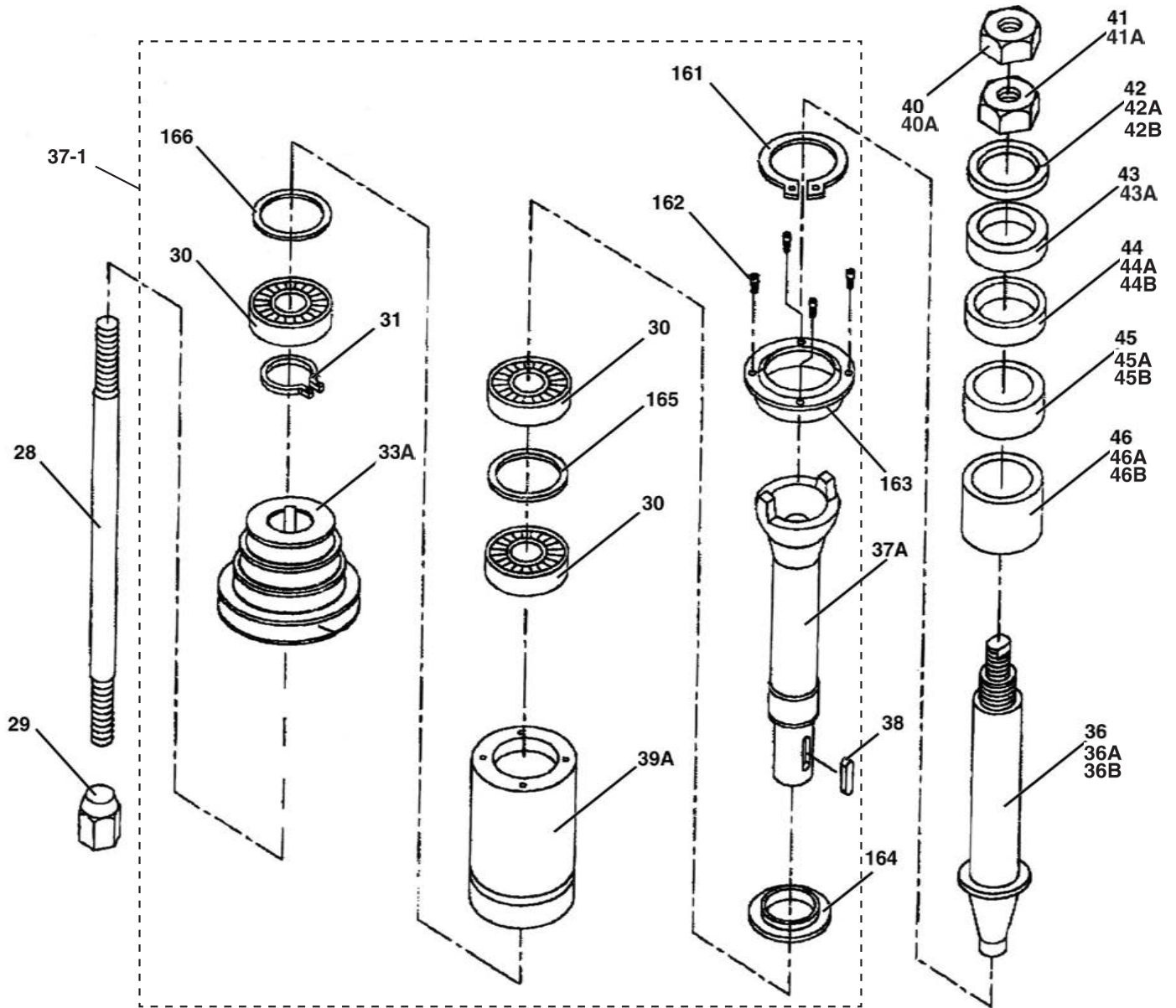

Spindle Parts List

REF	PART #	DESCRIPTION
28	P5912Z028	LOCK BOLT 3/8-11
29	P5912Z029	TAPER LOCK NUT
30	P5912Z030	BALL BEARING 6008ZZ
31	P5912Z031	EXT RETAINING RING 40MM
33A	P5912Z033A	SPINDLE PULLEY ASSEMBLY
36	P5912Z036	SPINDLE 1-1/4
36-2	P5912Z036-2	SPINDLE WRENCH 1-1/2"
36A	P5912Z036A	SPINDLE 3/4"
36B	P5912Z036B	SPINDLE 1"
36B-2	P5912Z036B-2	SPINDLE WRENCH 1"
37-1	P5912Z037-1	PULLEY AND QUILL ASSEMBLY
37A	P5912Z037A	SPINDLE PULLEY ASSEMBLY
38	P5912Z038	KEY 7 X 7 X 40
39A	P5912Z039A	QUILL 7-3/4" LONG V2.01.02
40	P5912Z040	HEX NUT 3/4-16 (LH)
40A	P5912Z040A	HEX NUT 5/8-18 (LH)
41	P5912Z041	HEX NUT 1-14
41A	P5912Z041A	HEX NUT 3/4-16
42	P5912Z042	COLLAR 1-1/4" X 1/4" 1PC
42A	P5912Z042A	COLLAR 1" X 1/4"
42B	P5912Z042B	COLLAR 3/4" X 1/4"

REF	PART #	DESCRIPTION
43	P5912Z043	COLLAR 1-1/4" X 3/8" 1PC
43A	P5912Z043A	COLLAR 1" X 3/8"
44	P5912Z044	COLLAR 1-1/4" X 1/2" 2PC
44A	P5912Z044A	COLLAR 1" X 1/2"
44B	P5912Z044B	COLLAR 3/4" X 1/2"
45	P5912Z045	COLLAR 1-1/4" X 3/4" 2PC
45A	P5912Z045A	COLLAR 1" X 3/4" (2PC)
45B	P5912Z045B	COLLAR 3/4" X 3/4" (2PC)
46	P5912Z046	COLLAR 1-1/4" X 1" 2PC
46A	P5912Z046A	COLLAR 1" X 1" (2PC)
46B	P5912Z046B	COLLAR 3/4" X 1" (2PC)
161	P5912Z161	EXT RETAINING RING 50MM
162	P5912Z162	CAP SCREW M4-.7 X 10
163	P5912Z163	OUTER DUST COVER
164	P5912Z164	INNER DUST COVER
165	P5912Z165	WAVY WASHER
166	P5912Z166	WAVY WASHER
417	P5912Z417	MULTI-WRENCH
419	P5912Z419	HEX WRENCH 3MM
420	P5912Z420	HEX WRENCH 4MM



Motor

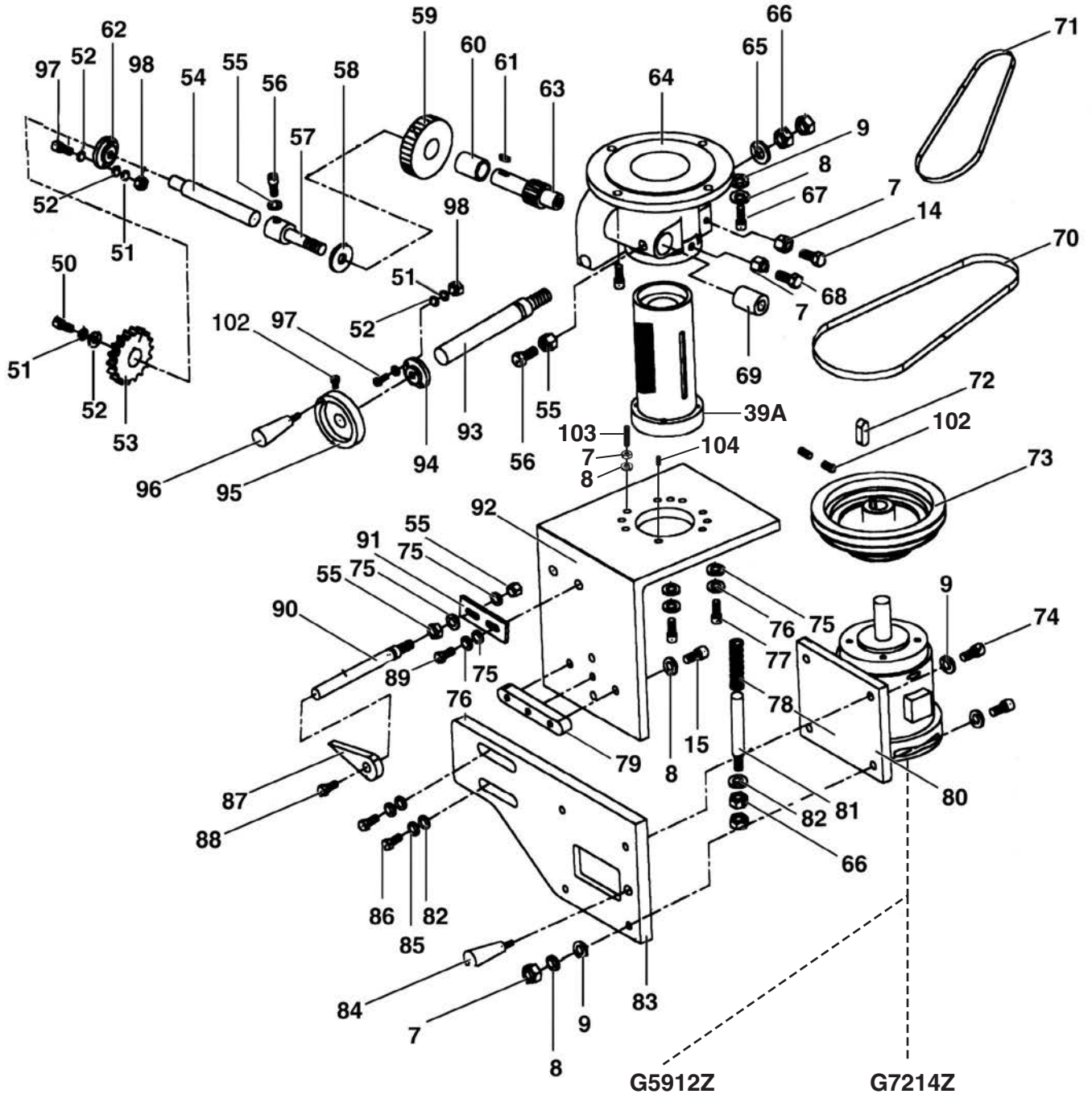

G5912Z

G7214Z

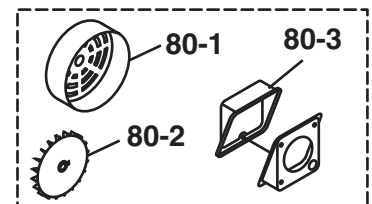
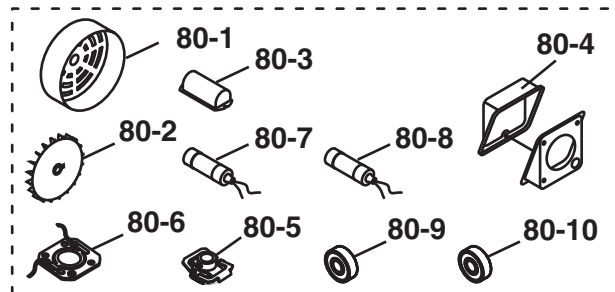

Motor Parts List

REF	PART #	DESCRIPTION
7	P5912Z007	HEX NUT 3/8-16
8	P5912Z008	LOCK WASHER 3/8
9	P5912Z009	FLAT WASHER 3/8
14	P5912Z014	HEX BOLT 3/8-16 X 1-1/4
15	P5912Z015	HEX BOLT 3/8-16 X 3/4
39A	P5912Z039A	QUILL 7-3/4" LONG V2.01.02
50	P5912Z050	HEX BOLT 1/4-20 X 5/8
51	P5912Z051	LOCK WASHER 1/4
52	P5912Z052	FLAT WASHER 1/4
53	P5912Z053	LOCK KNOB
54	P5912Z054	BAR LOCK
55	P5912Z055	HEX NUT 5/16-18
56	P5912Z056	HEX BOLT 5/16-18 X 1
57	P5912Z057	SCREW LOCK
58	P5912Z058	WASHER GEAR
59	P5912Z059	GEAR
60	P5912Z060	COLLAR
61	P5912Z061	KEY 4 X 4 X 16
62	P5912Z062	BASE GEAR SHAFT
63	P5912Z063	SHAFT GEAR
64	P5912Z064	BASE SPINDLE
65	P5912Z065	FLAT WASHER 1/2
66	P5912Z066	LOCK NUT 1/2"-12
67	P5912Z067	CAP SCREW 3/8-16 X 1-1/4
68	P5912Z068	SCREW 3/8-16 X 1-1/4
69	P5912Z069	COLLAR
70	P5912Z070	V-BELT A-30 4L300
71	P5912Z071	V-BELT A-28 4L280
72	P5912Z072	KEY 7 X 7 X 50

REF	PART #	DESCRIPTION
73	P5912Z073	MOTOR PULLEY
74	P5912Z074	HEX BOLT 3/8-16 X 1-1/2
75	P5912Z075	FLAT WASHER 5/16
76	P5912Z076	LOCK WASHER 5/16
77	P5912Z077	CAP SCREW 5/16-18 X 1
78	P5912Z078	COMPRESSION SPRING 3.4 X 20.3
79	P5912Z079	KEY 3/8 X 3/4 X 1
81	P5912Z081	SHAFT
82	P5912Z082	FLAT WASHER 1/2
83	P5912Z083	MOTOR BASE
84	P5912Z084	KNOB
85	P5912Z085	LOCK WASHER 1/2
86	P5912Z086	HEX BOLT 1/2-20 X 1
87	P5912Z087	POINTER
88	P5912Z088	PHLP HD SCR 10-24 X 3/8
89	P5912Z089	HEX BOLT 5/16-18 X 3/4
90	P5912Z090	SHAFT GUIDE
91	P5912Z091	PLATE
92	P5912Z092	MOTOR PLATE
93	P5912Z093	SHAFT GEAR
94	P5912Z094	BASE GEAR SHAFT
95	P5912Z095	HANDWHEEL (METAL)
96	P5912Z096	HANDLE
97	P5912Z097	HEX BOLT 1/4-20 X 1
98	P5912Z098	HEX NUT 1/4-20
102	P5912Z102	SET SCREW 10-32 X 3/16
103	P5912Z103	SET SCREW 3/8-16 X 1
104	P5912Z104	SET SCREW 3/8-16 X 1/2

G5912Z 5HP 1-PH MOTOR

REF	PART #	DESCRIPTION
80	P5912Z080	MOTOR 5HP, 220V, 1-PH
80-1	P5912Z080-1	MOTOR FAN COVER
80-2	P5912Z080-2	MOTOR FAN
80-3	P5912Z080-3	CAPACITOR COVER
80-4	P5912Z080-4	MOTOR JUNCTION BOX
80-5	P5912Z080-5	CENT SWITCH 1/2-3450
80-6	P5912Z080-6	CONTACT PLT-TUNGSTEN 5HP
80-7	P5912Z080-7	S CAP 400M 125V 1-3/4 X 3-3/8
80-8	P5912Z080-8	R CAPR 50M 250V 1-3/4 X 2-3/4
80-9	P5912Z080-9	REAR MOTOR BEARING
80-10	P5912Z080-10	FRONT MOTOR BEARING

G7214Z 7½HP 3-PH MOTOR

REF	PART #	DESCRIPTION
80	P7214Z080	MOTOR 7.5HP, 220V/440V, 3-PH
80-1	P7214Z080-1	MOTOR FAN COVER
80-2	P7214Z080-2	MOTOR FAN
80-3	P7214Z080-3	MOTOR JUNCTION BOX



Fence Guard

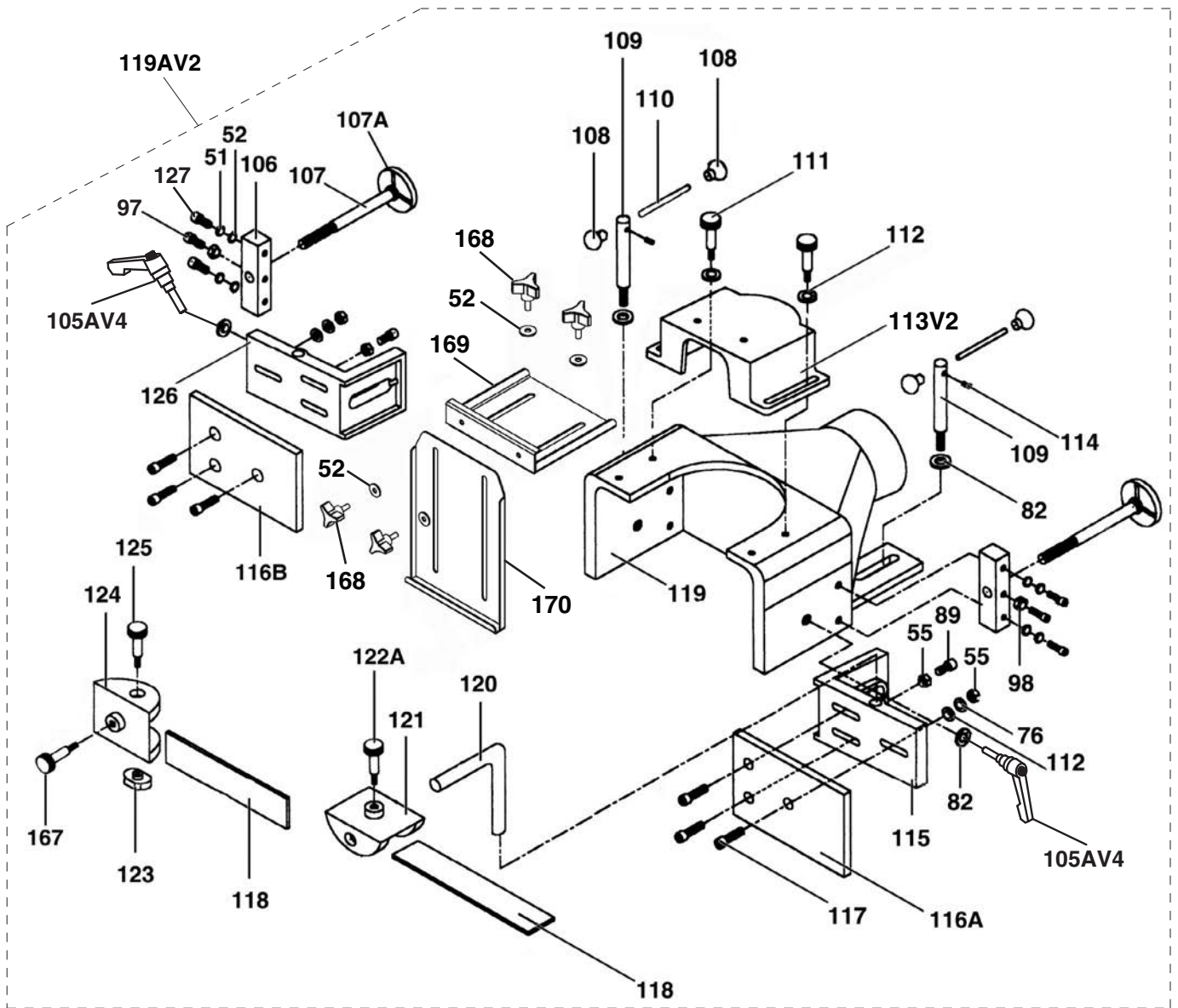

Fence Guard Parts List

REF	PART #	DESCRIPTION
51	P5912Z051	LOCK WASHER 1/4
52	P5912Z052	FLAT WASHER 1/4
55	P5912Z055	HEX NUT 5/16-18
76	P5912Z076	LOCK WASHER 5/16
82	P5912Z082	FLAT WASHER 1/2
89	P5912Z089	HEX BOLT 5/16-18 X 3/4
97	P5912Z097	HEX BOLT 1/4-20 X 1
98	P5912Z098	HEX NUT 1/4-20
105AV4	P5912Z105AV4	ADJ HANDLE 1/2-12 V4.03.16
106	P5912Z106	BRACKET SCREW GUIDE
107	P5912Z107	SCREW GUIDE ASSY
107A	P5912Z107A	HANDWHEEL
108	P5912Z108	BALL KNOB 3/8-16 (PLASTIC)
109	P5912Z109	SHAFT GUIDE
110	P5912Z110	BAR
111	P5912Z111	KNOB 5/16-18
112	P5912Z112	FLAT WASHER 5/16
113V2	P5912Z113V2	CUTTER GUARD COVER V2.01.17
114	P5912Z114	SET SCREW 1/4-20 X 1/4

REF	PART #	DESCRIPTION
115	P5912Z115	BRACKET ASSY FENCE RH
116A	P5912Z116A	WOOD FENCE (RIGHT)
116B	P5912Z116B	WOOD FENCE (LEFT)
117	P5912Z117	FLAT HD SCR 5/16-18 X 1-1/2
118	P5912Z118	HOLD DOWN PLATE
119	P5912Z119	CUTTER GUARD/DUST HOOD
119AV2	P5912Z119AV2	COMPLETE FENCE ASSY V2.01.17
120	P5912Z120	BAR
121	P5912Z121	RETAINER (L) 5/8"
122A	P5912Z122A	KNOB BOLT 3/8-16 X 1 V2.10.02
123	P5912Z123	NUT 3/8
124	P5912Z124	RETAINER (S) 1/2"
125	P5912Z125	KNOB
126	P5912Z126	BRACKET ASSY FENCE LH
127	P5912Z127	HEX BOLT 1/4-20 X 1-1/2
167	P5912Z167	KNOB BOLT 3/8-16 X 1
168	P5912Z168	KNOB BOLT 1/4-20 X 1/2
169	P5912Z169	FRONT GUARD EXTENSION PLATE
170	P5912Z170	FRONT SPINDLE ENCLOSURE GUARD



Labels & Cosmetics

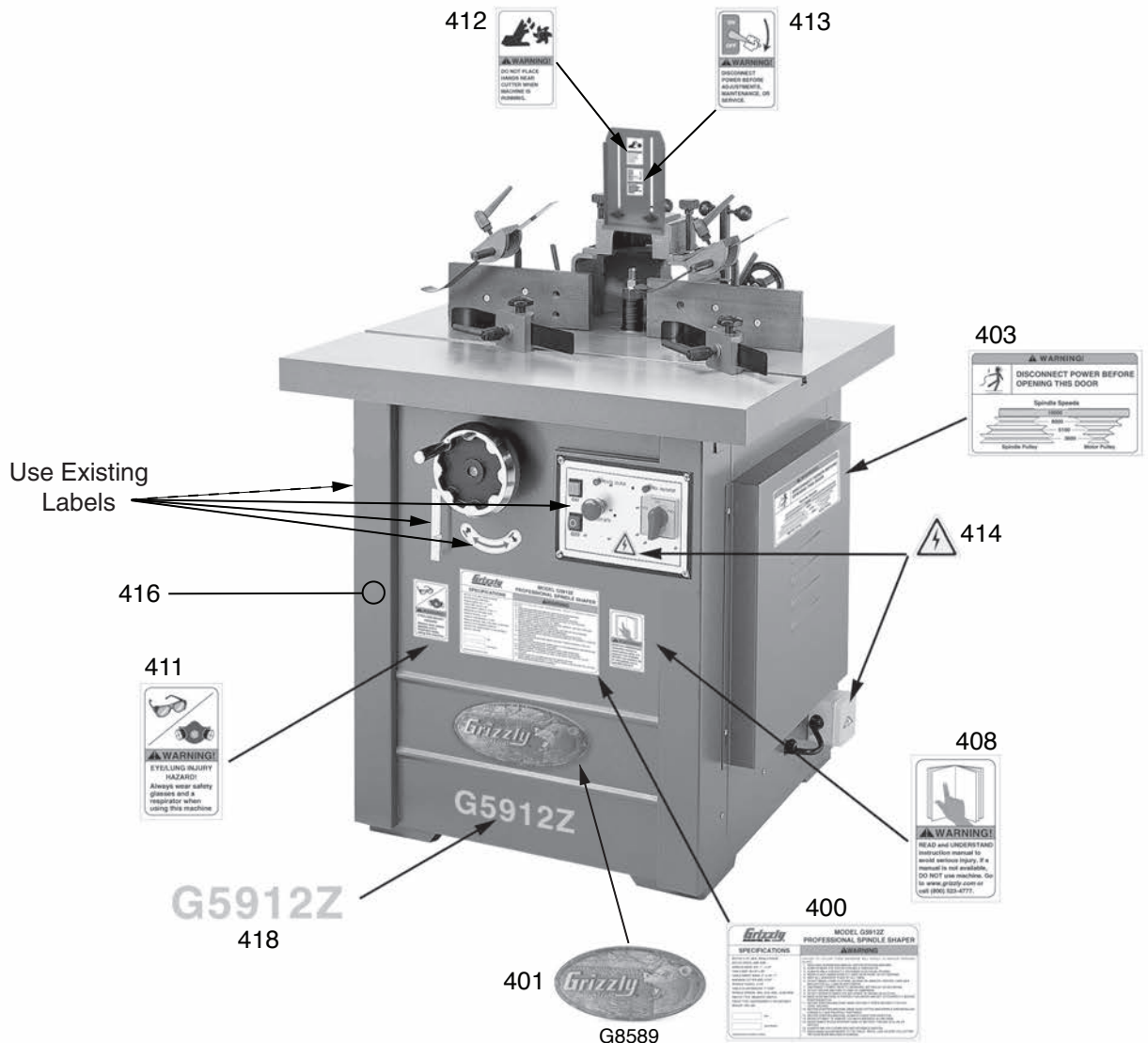

REF	PART #	DESCRIPTION
400	P5912Z400	MACHINE ID LABEL (G5912Z)
400	P7214Z400	MACHINE ID LABEL (G7214Z)
401	P5912Z401	GRIZZLY NAMEPLATE
403	P5912Z403	SPEED CHANGE LABEL
408	P5912Z408	READ MANUAL LABEL
411	P5912Z411	GLASSES/RESPIRATOR LABEL

REF	PART #	DESCRIPTION
412	P5912Z412	HAND NEAR CUTTER LABEL
413	P5912Z413	DISCONNECT POWER LABEL
414	P5912Z414	ELECTRICITY LABEL
416	P5912Z416	TOUCH-UP PAINT, GRIZZLY GREEN
418	P5912Z418	MODEL NUMBER LABEL (G5912Z)
418	P7214Z418	MODEL NUMBER LABEL (G7214Z)

WARNING

Safety labels help reduce the risk of serious injury caused by machine hazards. If any label comes off or becomes unreadable, the owner of this machine **MUST** replace it in the original location before resuming operations. For replacements, contact (800) 523-4777 or www.grizzly.com.



Notes

WARRANTY & RETURNS

Grizzly Industrial, Inc. warrants every product it sells for a period of **1 year** to the original purchaser from the date of purchase. This warranty does not apply to defects due directly or indirectly to misuse, abuse, negligence, accidents, repairs or alterations or lack of maintenance. This is Grizzly's sole written warranty and any and all warranties that may be implied by law, including any merchantability or fitness, for any particular purpose, are hereby limited to the duration of this written warranty. We do not warrant or represent that the merchandise complies with the provisions of any law or acts unless the manufacturer so warrants. In no event shall Grizzly's liability under this warranty exceed the purchase price paid for the product and any legal actions brought against Grizzly shall be tried in the State of Washington, County of Whatcom.

We shall in no event be liable for death, injuries to persons or property or for incidental, contingent, special, or consequential damages arising from the use of our products.

To register the warranty, scan the QR code below. You will be directed to the Warranty Registration page on Grizzly.com. Enter all applicable information for the product.



To take advantage of this warranty, contact us by mail or phone and give us all the details. We will then issue you a "Return Number," which must be clearly posted on the outside as well as the inside of the carton. We will not accept any item back without this number. Proof of purchase must accompany the merchandise.

The manufacturers reserve the right to change specifications at any time because they constantly strive to achieve better quality equipment. We make every effort to ensure that our products meet high quality and durability standards and we hope you never need to use this warranty.

Please feel free to write or call us if you have any questions about the machine or the manual.

Thank you again for your business and continued support. We hope to serve you again soon.

grizzly.com[®]
TOOL WEBSITE

Buy Direct and Save with Grizzly[®] – Trusted, Proven and a Great Value!
~Since 1983~

*Visit Our Website Today For
Current Specials!*

**ORDER
24 HOURS A DAY!
1-800-523-4777**

