

V-Max Elite Air Compressors

Installation and Operation Manual

Manual P/N 5900259 — Manual Revision A — November 2020

Models:

- VMP-7580V-601
- VMP-7580V-603
- VMP-10120V-603



VMP-7580V-601 shown.

Engineered by BendPak Inc. in Southern California, USA. Made in USA.

 **DANGER**

Read the contents of this manual thoroughly **before** installing, operating, servicing, or maintaining this product. Failure to follow the instructions and safety precautions in this manual can result in serious injury or death. Make sure all operators read this manual. Keep the manual near the product for future reference. **By proceeding with installation and operation, you agree you fully understand the contents of this manual and assume full responsibility for product use.**

Manual. V-Max Elite Industrial Air Compressors, *Installation and Operation Manual*, Manual Part Number 5900259, Manual Revision A, released November 2020.

Copyright. Copyright © 2020 by BendPak Inc. All rights reserved. You may make copies of this document if you agree that: you will give full attribution to BendPak Inc., you will not make changes to the content, you do not gain any rights to this content, and you will not use the copies for commercial purposes.

Trademarks. BendPak and the BendPak logo are registered trademarks of BendPak Inc. All other company, product, and service names are used for identification only. All trademarks and registered trademarks mentioned in this manual are the property of their respective owners.

Limitations. Every effort has been made to ensure complete and accurate instructions are included in this manual. However, product updates, revisions, and/or changes may have occurred since this manual was published. BendPak reserves the right to change any information in this manual without incurring any obligation for equipment previously or subsequently sold. BendPak is not responsible for typographical errors in this manual. The latest version of the manual for this product is **available on the BendPak website**.

Warranty. The BendPak warranty is more than a commitment to you: it is also a commitment to the value of your new product. Contact your nearest BendPak dealer or visit www.bendpak.com/support/warranty for full warranty details. Go to bendpak.com/support/register-your-product/ and fill out the online form to register your product (be sure to click **Submit**).

Safety. Your product was designed and manufactured with safety in mind. However, your safety also depends on proper training and thoughtful operation. Do not install, operate, maintain, or repair the unit without reading and understanding this manual and the labels on the unit; **do not use your unit unless you can do so safely!**

Owner Responsibility. In order to ensure operator safety and maintain your product properly, it is the responsibility of the product owner to read and follow these instructions:

- Follow all installation, operation, and maintenance instructions.
- Make sure product setup and use conforms to all applicable local, state, and federal codes, rules, and regulations, such as state and federal OSHA regulations and electrical codes.
- Read and follow all safety instructions. Keep them readily available for operators.
- Make sure all operators are properly trained, know how to safely operate the unit, and are properly supervised.
- Do not operate the product until you are certain all parts are in place and operating correctly.
- Carefully inspect the product on a regular basis and perform all maintenance as specified.
- Service and maintain the unit only with approved replacement parts.
- Keep all instructions permanently with the product and make sure all labels are clean and visible.
- **Only use the unit if it can be used safely!**

Unit Information. Enter the Model Number, PO Number, and the Job Number from the label on your unit. This information is for part or warranty issues.

Model: _____

PO: _____

Job: _____

		Model Number		Santa Paula, CA USA www.bendpak.com	
PO #	<input type="text"/>	Pump Model #	<input type="text"/>	Job #	<input type="text"/>
Motor	<input type="text"/>	<input type="text"/>	Maintenance Parts Air Filter <input type="text"/> Oil Type SYNTHETIC <input type="text"/> Oil Capacity <input type="text"/> Service Kit <input type="text"/> Date Code <input type="text"/> Inspector <input type="text"/>		
Phase	<input type="text"/>	<input type="text"/>			
Power Supply	<input type="text"/>	<input type="text"/>			
Full Load Run Amps	<input type="text"/>	<input type="text"/>			
Maximum Pressure	<input type="text"/>	<input type="text"/>			
SCFM @ 175 PSI	<input type="text"/>	<input type="text"/>			
Tank Size	<input type="text"/>	<input type="text"/>			
Unit Weight	<input type="text"/>				

FOR SALES, SERVICE, PARTS, OR TECHNICAL SUPPORT, CALL US AT (888) 856-5820.

Table of Contents

Introduction	3	Installation	13
Shipping Information	4	Operation	20
Safety Considerations	4	Maintenance	21
FAQs	7	Troubleshooting	27
Components	8	Wiring Diagram	28
Specifications	10	Labels	29
Important Electrical	11	Parts Diagram	31
Installation Checklist	12	Maintenance Log	35

Introduction

This manual describes the following V-Max Elite Air Compressors:

- **VMP-7580V-601**. 7.5HP Motor, 80 Gallon Tank, Single Phase.
- **VMP-7580V-603**. 7.5HP Motor, 80 Gallon Tank, Three Phase.
- **VMP-10120V-603**. 10HP Motor, 120 Gallon Tank, Three Phase.

More information about the full line of BendPak products is available at bendpak.com.

This manual is mandatory reading for all V-Max Elite Air Compressor users, including anyone who sets up, operates, maintains, or repairs it.

⚠ DANGER Be very careful when setting up, operating, maintaining, or repairing this equipment; failure to do so could result in property damage, product damage, injury, or (in very rare cases) death. Make sure only authorized personnel operate this equipment. All repairs must be performed by an authorized technician. Do not make modifications to the unit; this voids the warranty and increases the chances of injury or property damage. Make sure to read and follow the instructions on the labels on the unit.

Keep this manual on or near the equipment so that anyone who uses or services it can read it.

If you are having issues, refer to the **Troubleshooting** section of this manual for assistance.

Technical support and service is available from your dealer, on the Web at bendpak.com/support, by email at support@bendpak.com, or by phone at **(800) 253-2363**, extension 196.

You may also contact BendPak for parts replacement information (please have the model and serial number of your unit available) at **(800) 253-2363**, extension 191.

Shipping Information

Your equipment was carefully checked before shipping. Nevertheless, you should thoroughly inspect the shipment **before** you sign to acknowledge that you received it.

When you sign the bill of lading, it tells the carrier that the items on the invoice were received in good condition. **Do not sign the bill of lading until after you have inspected the shipment.** If any of the items listed on the bill of lading are missing or damaged, do not accept the shipment until the carrier makes a notation on the bill of lading that lists the missing and/or damaged goods.

If you discover missing or damaged goods **after** you receive the shipment and have signed the bill of lading, notify the carrier at once and request the carrier to make an inspection. If the carrier will not make an inspection, prepare a signed statement to the effect that you have notified the carrier (on a specific date) and that the carrier has failed to comply with your request.

It is difficult to collect for loss or damage after you have given the carrier a signed bill of lading. If this happens to you, file a claim with the carrier promptly. Support your claim with copies of the bill of lading, freight bill, invoice, and photographs. Our willingness to assist in helping you process your claim does not make us responsible for collection of claims or replacement of lost or damaged materials.

Safety Considerations

Read this manual carefully before using your new product. Do not set up or operate the product until you are familiar with **all** operating instructions and warnings. Do not allow anyone else to operate the product until they are also familiar with all operating instructions and warnings.

 **DANGER** When you even hear the words “air compressor,” you need to remember that being in close proximity to one is a serious endeavor with potentially life-threatening risks. The Compressor can start without warning. An accidental quarter turn on a ball valve can unleash pressurized air at potentially dangerous levels. Only allow trained personnel anywhere near the Compressor. **Do not assume you are going to be safe this time just because nothing happened last time.**

General Safety Information

- The product is an Air Compressor. Use it only for its intended purpose.
- Do not make any modifications to the Compressor. If you do, you void your warranty.
- Do not override, remove, or disable Compressor safety features or components; they are there for your safety. Do not use the Compressor if safety features or components have been overridden, removed, disabled, or damaged.
- Never operate Compressor without the Belt Guard; this unit can automatically start without warning.
- The Compressor must **only** be operated by authorized personnel. Take **active measures** to keep untrained personnel away from the unit.
- You **must** wear OSHA-approved (publication 3151) personal protective equipment at all times when installing, using, maintaining, or repairing the Compressor: leather gloves, steel-toed work boots, eye protection, back belts, and hearing protection.
- When the product is in use, keep away from it. Only trained Operators should be within 30 feet.
- Make a visual inspection of the unit on a **daily** basis. Check for damaged or missing parts. Do not use the product if you find any issues. Instead, take it out of service, tag it out and lock it out, then

contact your dealer, email support@bendpak.com, visit bendpak.com/support, or call **(800) 253-2363**.

- Make a **thorough** inspection of the unit at least once a year. Replace any damaged or severely worn parts, decals, or warning labels.
- Make sure all Operators read and understand the *Installation and Operation Manual*. Keep the manual near the device at all times.
- If you are using the Compressor to paint, keep the paint far away from the Compressor.

 **DANGER** The pressurized air generated by the Compressor is **not** human breathable when it leaves the Compressor. If you want it to be human breathable, additional equipment is **required**. Refer to the current version of the Compressed Gas Association (CGA, an ANSI-approved standards developing organization) for information about what is required for human breathable air. CGA G-7.1-2018 was the current version at the time of this writing.

Symbols

Following are the symbols used in this manual:

 **DANGER** Calls attention to an immediate hazard that **will** result in injury or death.

 **WARNING** Calls attention to a hazard or unsafe practice that **could** result in injury or death.

 **CAUTION** Calls attention to a hazard or unsafe practice that could result in minor personal injury, product, or property damage.

NOTICE Calls attention to a situation that, if not avoided, could result in product or property damage.



Tip

Calls attention to information that can help you use your product better.

Liability Information

BendPak Inc. assumes **no** liability for damages resulting from:

- Use of the product for purposes other than those described in this manual.
- Modifications to the equipment without prior, written permission from BendPak Inc.
- Modifying, disabling, overriding, or removing safety features.
- Failure to perform maintenance tasks as described in this manual.
- Damage to the equipment from external influences.
- Incorrect operation of the equipment.

Frequently Asked Questions

Question: What does an Air Compressor do?

Answer: An Air Compressor compresses air, making it into a power source: pressurized air. That pressurized air can then be used to power pneumatic tools and other things.

⚠ DANGER The pressurized air generated by the Compressor is ***not human breathable*** when it leaves the Compressor. If you want it to be human breathable, additional equipment is ***required***. Refer to the current version of the Compressed Gas Association (CGA, an ANSI-approved standards developing organization) for information about what is required for human breathable air.

Q: Can the Compressor be installed outside?

A: Technically yes, but we advise against it. Air compressors are designed to be installed indoors. If your Compressor is outside, the intake air will be dirtier (a significant issue), the electrical components will be subject to extra moisture (including water), and all of the components will be subjected to a harsher environment (cold, wind, rain, humidity, and so on). You will need special protections and accommodations for the unit if you install it outside.

Q: What psi/bar does the Compressor provide?

A: The maximum pressure is regulated to 175 psi / 12 bar. The automatic turn-on pressure is 135 psi / 9.3 bar, the automatic shut-off pressure is 175 psi / 12 bar.

Q: What are cfm and psi?

A: cfm is the volume (the amount) of air being delivered. psi is the force at which that air is being delivered. cfm stands for cubic feet per minute, psi stands for pounds per square inch.

Components

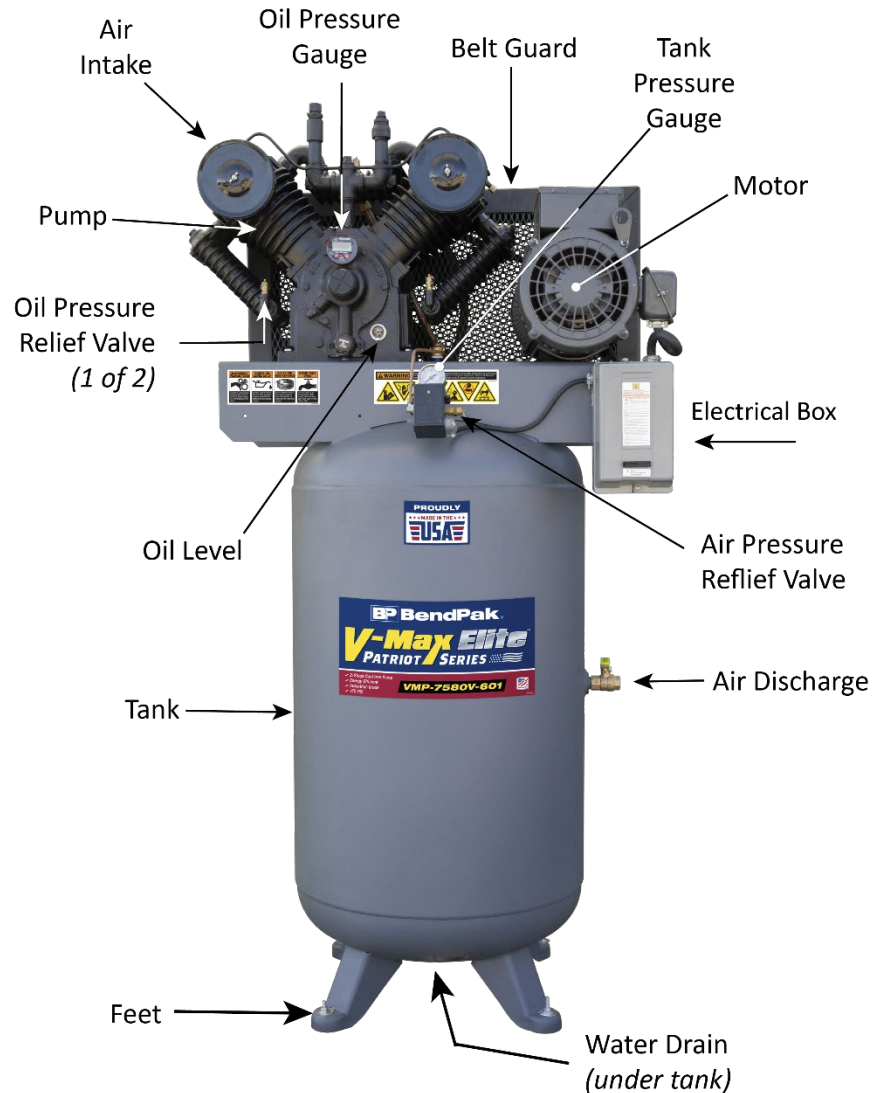

Not all components visible.

Compressor components include:

- **Air Intake.** Where outside air is pulled in, on its way to the Compressor. There is a filter inside that cleans the air, so that the Compressor uses the cleanest air possible.
- **Pump.** Two stage, splash lubricated. Compresses the air and then moves it into the Tank. Lubricated by compressor oil.
- **Motor.** Provides power to the Compressor.

- **Electrical Box.** The power source connects to the Compressor on the inside of the Electrical Box.

The following graphic shows the Electrical Box.

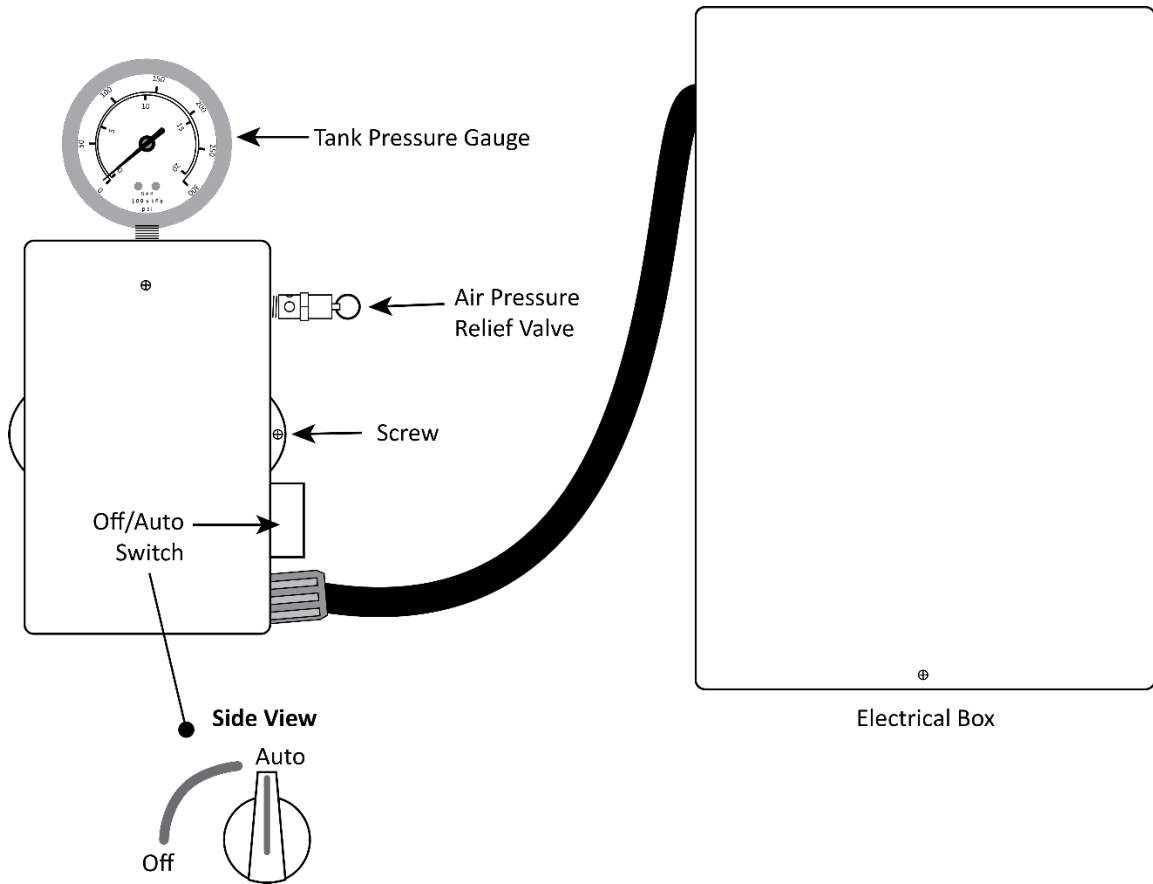

Not drawn to scale. Not all components are shown.

- **Tank.** Stores the pressurized air created by the Compressor.
- **Air Discharge.** Where pressurized air leaves the Tank. Includes a valve for opening and closing.

⚠ WARNING Be careful opening the Air Discharge valve if it is not connected to the shop's piping system. Even if the Compressor is not running, the Tank could be full of pressurized air, which is dangerous to release if you are not paying attention.

- **Tank Pressure Gauge.** Shows the Air Pressure in the Tank.
- **Air Pressure Relief Valve.** Stops the Motor when air pressure in the Tank reaches 175 psi. ASME certified. Do **not** remove or adjust the Valve; if you do, you put people in danger and void the warranty. Do **not** manually open the Valve while there is air pressure in the Tank.
- **Oil Pressure Gauge.** Shows the Oil Pressure in the Pump.
- **Oil Pressure Relief Valves.** Stops the Motor if oil pressure in the Pump exceeds a preconfigured threshold. Do **not** remove or adjust the Valve.
- **Oil Level.** Shows the oil level in the Pump. Must be in the middle of the red circle.
- **Belt Guard.** Protects the Belt, which is turned by the Motor.

Principles of Operation

The Compressor has four main components:

- **Motor.** Powered by electricity, the Motor provides power to the Pump. The Motor must be connected to an appropriate power source during installation; ***all electrical work requires a licensed, certified Electrician.*** Once installed, you turn on the Motor and thus the Compressor using the Off/Auto switch on the front of the Compressor.
- **Pump.** Powered by the Motor, the Pump compresses air it takes in into a smaller physical space, which pressurizes it. After it is pressurized, the Pump moves it into the Tank. The Pump on the Compressor is two stage, splash lubricated. Two stage means it compresses the air first in one cylinder and then compresses it more in a second cylinder. Splash lubricated means the unit uses oil for lubrication (some compressor pumps are oil free, which has different plusses and minuses).
- **Tank.** The Tank holds pressurized air. The pressurized air can get out of Tank in two ways: the main way is through the Air Discharge port on the side of the Tank. This port gets hooked up to the shop's compressed air piping system, which makes the pressurized air available around the shop. The second way is through the Water Drain on the underside of the Tank. Normally you use the Water Drain to drain water from the bottom of the Tank (where it accumulates over time) when there is no pressurized air in the Tank. But you can also use it when there is pressurized air in the Tank, in which case both pressurized air and water are going to come out.
- **Pressure Switch.** The Pressure Switch monitors the air pressure in the Tank and turns off the Motor when the pressure reaches its high-end threshold. In the case of the VMP Elite Air Compressors, the air pressure high-end threshold is 175 psi. When the Motor is turned off, that stops any more air from being compressed. The Pressure Switch keeps monitoring the air pressure in the Tank, because as the pressurized air in the Tank is used, the pressure in the Tank lowers. When the pressure in the Tank hits the low-end threshold, the Pressure Switch turns the Motor back on, which starts the Pump making more pressurized air and moving the pressure in the Tank back up. The operation of the Pressure Switch is what makes the Compressor go on and off at seemingly random times.

Specifications

Model	VMP-7580V-601	VMP-7580V-603	VMP-10120V-603
Motor Horsepower	7.5 HP	7.5 HP	10 HP
RPM	1,750	1,750	1,750
Voltage	220–240 VAC	220–240/460 VAC	220-240/460 VAC
Phase	1 Ph	3 Ph	3 Ph
Noise	~73 dB	~73 dB	~76 dB
SCFM @ 175 psi	26 SCFM	26 SCFM	35 SCFM
Maximum psi	175 psi / 12 bar	175 psi / 12 bar	175 psi / 12 bar
Tank Orientation	Vertical	Vertical	Vertical
Tank Size	80 gallon / 302.8 liter	80 gallon / 302.8 liter	120 gallon / 454 liter
Tank Outlet	¾ in / 19 mm fitting	¾ in / 19 mm fitting	1 in / 25 mm fitting
Weight	800 lb / ~363 kg	1,043 lb / ~473 kg	1,242 lb / ~563 kg

Specifications subject to change without notice.

Important Electrical Information

⚠ DANGER Electrical installation, service, and all electrical connections **must** be done by a qualified, licensed Electrician who is familiar with all applicable electrical codes.

General. The motor rating, as shown on the motor nameplate, and power supply must have compatible voltage, phase, and hertz characteristics. **Make sure to have your Electrician check all wiring connections when they are connecting the Compressor to power; sometimes wiring becomes loose during transportation.**

Wire Size. The electrical wiring between the power supply and electric motor varies according to motor horsepower and other factors. Install adequately sized power leads to protect against excessive voltage drop during pressure loaded start-up. Refer to the applicable electric codes in your area for information on selecting the proper wire size and securing electrical connections.

Minimum Wire Size. (Use 75°C copper wire). Make sure voltage is correct with the motor wiring. Refer to the motor label for the running HP rating. This will determine the wire size needed. Recommended wire sizes may be larger than the minimum set up by local ordinances. If so, the larger wire size should be used to prevent excessive line voltage drop.

The additional wire cost is very small compared with the cost of repairing or replacing a Motor electrically “starved” by the use of supply wires that are too small. Also, if a lead wire longer than 10 feet is needed, consult a local Electrician for alternative wiring options.

Minimum Wire Size and Branch-Circuit, Short-Circuit, and Ground-Fault Protection Devices							
Model	HP	Ph	Voltage (VAC)	Full Load Ampere	Inverse Time Breaker Maximum Allowable Size (A)	Dual Element Fuse Maximum Allowable Size (A)	Min. Wire Size (copper wire at 75°C)
VMP-7580V-601	7.5	1	220-240	32.8-30	100	70	6 AWG
VMP-7580V-603	7.5	3	220-240	24.2-22	60	40	6 AWG
VMP-10120V-603	10	3	220-240	28-25.3	70	50	4 AWG

Note 1: Table provides branch-circuit, short-circuit, and ground fault protection device sizes and required copper wire size at 75°C and up to 10 feet long. For longer distances, proper (larger) wire size must be determined and installed by local, licensed Electrician to prevent excessive voltage drop. Refer to motor label for motor HP, voltage, and phase to determine minimum wire size; **do not use undersized wire.**

Note 2: Smaller inverse time-trip breakers and dual element fuses may be used when recommended by a licensed Electrician. However, using an improper (too small) breaker may cause nuisance breaker tripping, which interferes with normal operation of the Compressor and could cause damage to the Compressor’s electric motor and other electrical components.

Fuses / Circuit Breakers. Refer to applicable local codes to determine the proper fuse or circuit breaker rating required.

Grounding. In the event of an electrical short circuit, grounding reduces the risk of electric shock by providing an escape wire for the electric current. Ground terminals are identified with a ground symbol and/or the letters “G”, “GR” or “PE” (Potential Earth).

⚠ WARNING Improper grounding can result in electrical shock and can cause severe injury or death. This product must be connected to a grounded, metallic, permanent wiring system or an equipment-grounding terminal or lead. All grounding must be

performed by a qualified, licensed Electrician and must comply with all applicable electric codes.

Installation Checklist

Following are the steps needed to install the Compressor. Perform them in the order shown.

- 1. Review the installation Safety Rules.
- 2. Make sure you have the necessary Tools.
- 3. Select the Installation site.
- 4. Move the Compressor into position.
- 5. Make sure there is adequate Clearance on all sides and above.
- 6. Anchor the Feet.
- 7. Connect to a Power Source.
- 8. Check the Oil Level.
- 9. Connect the Discharge Port.
- 10. Perform an Operational Test.
- 11. Review the Final Checklist.

Installation

This section describes how to install your Compressor. Perform the steps in the order listed.

 **WARNING** Use only the factory-supplied parts that came with your unit. If you use parts from a different source, you void your warranty and compromise the safety of everyone who installs or uses the Compressor. If you are missing parts, visit bendpak.com/support or call **(800) 253-2363**, extension 191.

Safety Rules

When installing the Compressor, your safety depends on proper training and thoughtful operation.

 **WARNING** Do not install this equipment unless you have Compressor installation training. Always use proper tools, such as a Forklift, to move heavy components. Do not install the unit without reading and understanding this manual and the safety labels on the unit.

Only fully trained personnel should be involved in installing this equipment. ***Pay attention at all times.*** Use appropriate tools and equipment. Stay clear of moving parts.

 **WARNING** You must wear OSHA-approved (publication 3151) personal protective equipment ***at all times*** when installing the Compressor. Leather gloves, steel-toed work boots, eye protection, back belts, and hearing protection are ***mandatory***.

Tools

You may need some or all of the following tools:

- Two adjustable wrenches, one pipe wrench
- Socket and ratchet set
- Medium slot and Philips screwdriver
- Forklift
- Rotary hammer drill or similar
- Masonry bits

The Electrician may require additional tools.

Select a Location

Keep the following in mind when selecting a location:

- **Indoor installation.** The Compressor works best with clean, dry air, which is found *indoors*. If you install the Compressor outdoors, the air is wetter and dirtier; outside air ***must*** be filtered before it can be used with the Compressor.
- **Clearance.** You must have adequate space on all sides and above. See **Clearance** for more information. Make sure the Compressor is at least 3.3 feet / 1 meter from a wall or corner, with at least 3.3 feet / 1 meter of open space ***above*** the unit (for good air circulation).
- **Floor.** Install your Compressor on a flat, dry concrete floor.
- **Power.** You will need a 220–240 VAC power source available near the Compressor.

- **Operating temperature.** The Compressor is designed to be used between temperatures of 41° to 104°F (5° to 40°C). You must **not** operate the Compressor at temperatures below 15 °F (-9°C) or above 125 °F (51°C).
- **Second floor installs.** Do not install the Compressor on a second floor or elevated floor without first consulting the building architect and getting their permission.
- **Ventilation.** Install the Compressor in a well-ventilated area, away from sources of contamination such as dirt or dust. Installing the Compressor in a dust-filled environment is **not acceptable**; it will damage the Compressor and it voids your warranty. Do not install the Compressor in a boiler room, paint spray room, or sandblasting area.

⚠ DANGER The pressurized air generated by the Compressor is **not** human breathable when it leaves the Compressor. If you want it to be human breathable, additional equipment is **required**. Refer to the current version of the Compressed Gas Association (CGA, an ANSI-approved standards developing organization) for information about what is required for human breathable air.

- **Moisture.** The Compressor's Motor should not get wet. Do not install the Compressor under cold water lines or other low temperature piping; condensation could drip water onto the unit, leading to rusting and/or the Motor shorting out. If you are using the Compressor in a humid environment, consider draining the Tank more frequently and/or using additional equipment to dry the air.

Moving the Compressor

There are two appropriate ways to move the Compressor:

- **Move the Pallet the Compressor is on using a Forklift.** One way to move your Compressor to the desired location is to use a Forklift from underneath while the Compressor is still on its pallet. Make sure the Compressor is firmly secured to the Pallet before moving it.
- **Move the Compressor from Above.** If you want to move the Compressor from above, use a sling under the Pump and Motor and above the Tank. Be sure to follow OSHA standards 29 CFR 1910, subpart N (including 1910.176 Handling materials – general and 1910.184 Slings).

Do **not** try to lift the Compressor from above by lifting on individual components, such as the Pump or the Motor.

⚠ CAUTION Do **not** lift the Compressor by the Motor or the Pump; you will damage the unit and void your warranty.

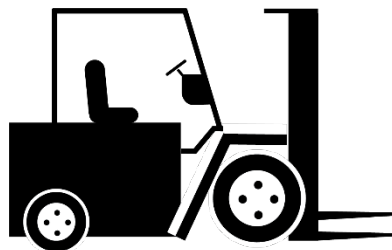

Clearance

The Compressor has two clearance zones:

- **Ventilation/Maintenance Zone.** Always keep at least 3.3 feet / 1 meter completely clear around the Compressor, even if it is in a corner or against a wall. This ensures an unobstructed flow of air to the Compressor and allows adequate space for maintenance. **Required.**
- **Safety Exclusion Zone.** BendPak strongly recommends keeping 6.6 feet / 2 meters clear around the Compressor for safety purposes. Only trained Operators should ever be allowed inside the Safety Exclusion Zone; **nothing else**—no half-finished projects, no wires or cables, no storage, no chemicals, no things you're going to get to next week. **Strongly recommended.**

The Safety Supervisor at the facility should implement appropriate written policies and physical safeguards including, if possible, a physical barrier around the Safety Exclusion Zone.

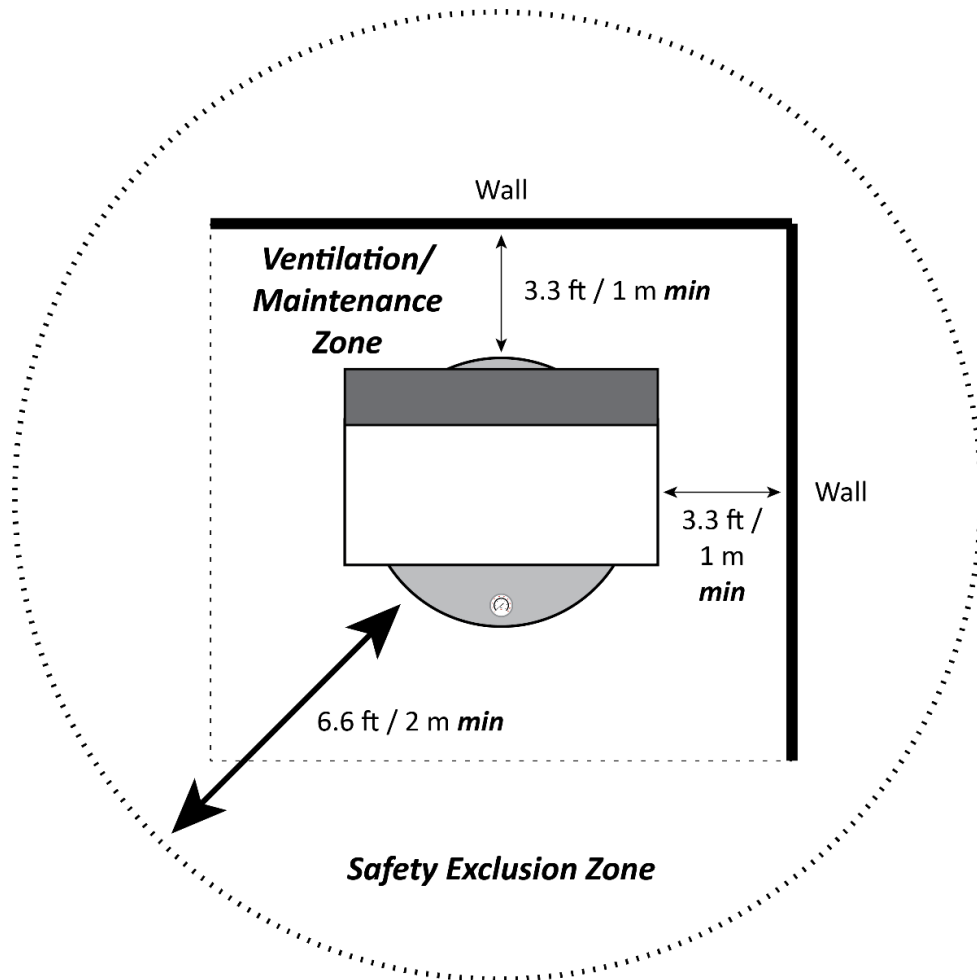

Top view. Not necessarily to scale. Not all components shown.

⚠ DANGER When you even hear the words “air compressor,” you need to remember that being in close proximity to one is a serious endeavor with potentially life-threatening risks. The Compressor can start without warning. An accidental quarter turn on a ball valve can unleash pressurized air at potentially dangerous levels. Only allow trained Operators near the Compressor. **Do not assume everything will be OK this time just because nothing happened last time.**

Anchor the Feet

You must anchor the Compressor to a flat, dry concrete floor and make sure the unit is level.

Anchoring provides extra stability for the unit. Leveling ensures the splash lubrication works properly.

Important: Use .25 inch / 6.35 mm anti-vibration pads between the Compressor feet and the ground.

Recommended Anchor Bolt specifications: wedge anchors; 3/8 in wide by 3.5 in deep.

To anchor the Compressor feet:

1. Make sure the Compressor is in the desired location and the anti-vibration pads are under the feet of the Compressor.
2. Using the holes in the feet as guides, drill the holes for the anchor bolts through the anti-vibration pads and into the concrete.

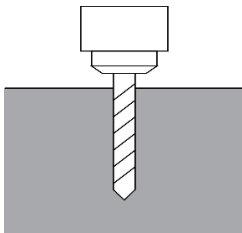

Go in straight; do not let the drill wobble.

Use a carbide bit (conforming to ANSI B212.15).

The diameter of the drill bit **must** be the same as the diameter of the anchor bolt. So if you are using a 3/8 inch diameter anchor bolt, for example, use a 3/8 inch diameter drill bit.

3. Use a vacuum to thoroughly clean each hole.

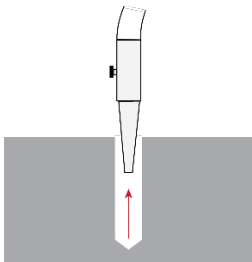

If a vacuum is not available, use a wire brush, hand pump, or compressed air.

Do **not** ream the hole. Do **not** make the hole any wider than the drill bit made it.

4. Put the washer and nut into place, make sure the top of the nut is flush with the top of the anchor bolt, then insert the anchor bolt into the hole.
5. Hammer or mallet the anchor bolt down into the hole.

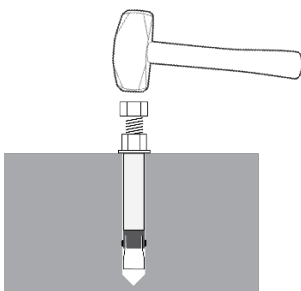

Stop hammering when the washer is snug against the top of the foot.

6. Tighten each nut **clockwise**, make each nut snug, but do not overtighten.
If you overtighten the nuts, normal vibration may cause damage to the Compressor.

Important: Do **not** use an impact wrench to tighten the Anchor Bolts.

7. Make sure the Compressor is level; use Shims if necessary.

Connect to a Power Source

The Electrical Box comes from the factory already wired to the Motor, so the Electrician only needs to wire the Electrical Box to the facility's electrical system or to a power cord and plug.

⚠ DANGER All electrical work **must be done by a licensed, certified Electrician in accordance with all applicable local electrical codes**. Damage caused by improper electrical installation may void your warranty.

All electrical work **must** conform to applicable local, state, and federal codes, rules, and regulations, such as state and federal OSHA regulations and electrical codes. The Compressor **must** be grounded.

Important: BendPak strongly recommends having your Electrician check all wire connections inside the Electrical Box; sometimes they can become loose during transport.

The Electrician needs to:

- Wire the Compressor directly into the facility's electrical system, or
- Add a power cord with appropriate plug to the Compressor, which is then plugged in to an appropriate power source.

The Electrician needs to provide the plug and/or the cord; they are **not** supplied with the Compressor.

Important: The Compressor uses electrical energy and creates pneumatic energy; if your organization has Lockout/Tagout policies, make sure to implement them after connecting the Compressor to a power source.

Refer to **Important Electrical Information** and to the ID plate on the Motor for additional information.

To connect the Compressor to a power source:

1. Work with the Electrician to decide whether you are going to wire the Compressor directly into the facility's electrical system or connect a power cord with appropriate plug.

Make sure to put the Compressor on a dedicated circuit. Do not wire any other electrical equipment into the circuit breaker.

2. Have your Electrician get the necessary components.
3. Make sure the Off/Auto Switch on the front of the Compressor is set to Off.
4. Remove the small screws on the side of the Electrical Box and remove the Cover.
5. Check the connections inside the Electrical Box to make sure they are secure.

See **Wiring Diagrams** for more wiring information.

⚠ WARNING Make sure the Compressor is properly grounded; this can prevent serious injury and, potentially, death. **Improperly grounded electrical components are shock hazards.**

6. Replace the cover of the Electrical Box and screw it back in.
7. If your Electrician wired a power cord with plug, plug it in to an appropriate outlet.

⚠ WARNING The Compressor uses electrical energy and creates pneumatic energy; if your organization has Lockout/Tagout policies, implement them after connecting the Power Unit to a power source.

8. Turn the button on the front of the Compressor to **Auto**.

Check the Oil Level

The Compressor comes with oil/lubricant. The amount of oil should be in the middle of the red circle.

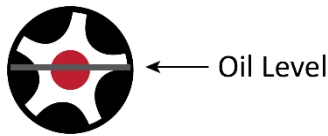

Not necessarily to scale. Not all components shown.

Check the oil level every time you start up the Compressor. Adjust the oil level if necessary.

⚠ WARNING Do not overfill or under fill the oil. If you overfill, there could be too much oil in the pressurized air. If you under fill, the Compressor could overheat and be permanently damaged, which voids the warranty.

When you require additional oil, get synthetic, SAE grade 30, piston air compressor oil.

Connect to the Air Discharge

Connect the Tank's Air Discharge port to the facility's compressed air piping system.

The Air Discharge port for VMP-7580V-601 and VMP-7580V-603 is a **3/4 in / 19 mm** fitting.

The VMP-10120V-603 model requires a **1 in / 23 mm** fitting.

⚠ CAUTION Be careful opening the Air Discharge valve if it is not connected to the shop's piping system. Even if the Compressor is not running, the Tank could be full of pressurized air, which is dangerous to release if you are not paying attention.

If the facility does not already have a compressed air piping system, you need to create one.

Creating a compressed air piping system is out of the scope of this document; BendPak recommends consulting with a professional.

⚠ WARNING Do **not** use PVC for your compressed air piping system. It will get brittle and then crack or burst, which could cause damage to the facility and injure bystanders. All components of the shop's compressed air piping system **must** have a pressure rating of 200 psi or greater.

If you want more information about how to create a compressed air piping system for a shop, search the Internet for "compressed air system for shop"; you will find products, videos, and articles.

Perform an Operational Test

Before putting the Compressor into normal operation, you need to test it.

To perform an Operational Test:

1. Check the area around the Compressor for people or obstructions; move them away if you find any.
2. Check the oil level; add oil if necessary.
The Compressor comes with oil. When you need additional oil, use synthetic, SAE grade 30, piston air compressor oil.
3. Check for proper Belt tension.
Refer to **Checking Belt Tension** for complete instructions.
4. Close the valve at the Discharge Port; we are just testing the Compressor right now.
5. Turn the Off/Auto Switch from Off to Auto; it is on the side of the Electrical Box.
The Motor starts running and the Pump starts compressing air.
6. Monitor the gauges to make sure they show operation in normal ranges.
Check for abnormal noises or vibrations.
Look for any oil leakage.

 **WARNING** Use care around the Compressor. Keep all body parts away from the Compressor at all times. Remember that it can start up unexpectedly **without warning**.

7. Turn the Off/Auto Switch from Auto to Off.
The Motor stops running and the Pump stops compressing air.
8. Carefully open the valve at the Discharge Port and let out the pressurized air.
When the Tank Pressure Gauge reads 0 and you no longer hear air coming out, you can close the valve at the Discharge Port.

Final Checklist Before Operation

Make sure these things have been done before using your Compressor:

- Review the **Installation Checklist** to make sure all steps have been performed.
- Make sure the Motor is getting power.
- Check for any oil leaks.
- Check the facility's compressed air piping system for leaks.
- Check to see that all anti-vibration pads and Anchor Bolts are correctly installed.
- Leave the Manual with the owner/operator.

Operation

This section describes how to operate your Air Compressor.

⚠ DANGER When you even hear the words “air compressor,” you need to remember that being in close proximity to one is a serious endeavor with potentially life-threatening risks. The Compressor can start without warning. An accidental quarter turn on a ball valve can unleash pressurized air at potentially dangerous levels. Only allow trained personnel near the Compressor. ***Do not assume you are going to be safe this time just because nothing happened last time.***

Safety First

Before using the Compressor, do the following:

- **Check the unit.** Check the Compressor for any missing, heavily worn, or damaged parts. Do not operate the Compressor if you find any of these issues; instead, take it out of service, lock it out and tag it out, then contact your dealer, email support@bendpak.com, visit bendpak.com/support, or call **(800) 253-2363**, extension 196.
- **Check the area.** Check the area around the Compressor for obstructions or people; anything that might impact normal operation of the Compressor. Do not forget to check **above** the Compressor. If you find an obstruction, move it out of the way. Do not allow anyone inside the Safety Exclusion Zone while it is connected to a power source.
- **Check for safety.** Make sure everyone who is going to be walking near the Compressor is aware of its presence and takes appropriate safety measures. Do not allow children to operate or stay near the Compressor. Do not allow anyone under the influence of drugs or alcohol to operate the Compressor. Only trained personnel should ever be allowed inside the Safety Exclusion Zone or be allowed to operate the Compressor.

Anything that could impact the safety of the people in the vicinity of the Compressor **must** be fully resolved before the Compressor can be used. ***Only use the unit if it can be used safely.***

Starting Up

If your Compressor passed the Operational Test, putting it into operation can be done quickly.

To start your Compressor:

1. Open the valve at the Discharge Port.

The Discharge Port should already be connected to the shop’s compressed air piping system. If it is not, connect it, then open the Discharge Port using the valve.

2. Check the oil level; add oil if necessary.

The Oil Level should be in the middle of the red circle.

3. Turn the Off/Auto Switch from Off to Auto.

The Compressor starts up and begins pressurizing air and storing it in the Tank.

The Compressor will stop running when pressure in the Tank reaches 175 psi. It will come back on automatically when the pressure goes down to 135 psi.

Maintenance

You must perform maintenance on the Compressor as described in the [Maintenance Schedule](#).

⚠ CAUTION If you do not perform maintenance on the Compressor, you risk permanent damage to the Compressor and you void your warranty.

The Compressor creates pneumatic energy and uses electrical energy. Before performing any Maintenance, you must take active measures to ensure that both of these energy types are de-energized and cannot be re-energized during Maintenance.

⚠ DANGER Before performing any Maintenance tasks, you must perform a Planned Shutdown of the Compressor. This ensures that the device is disconnected from its power source and cannot be re-energized until the Maintenance tasks are complete and that the device has had all air pressure released.

Planned Shutdown

For safety, you must perform a Planned Shutdown **before** doing any Maintenance or Troubleshooting.

Any Planned Shutdown should include:

- A plan. Including a checklist with activities to be performed, Lockout/Tagout equipment needed, and OSHA-approved (publication 3151) personal protective equipment needed.
- A single person who decides when the Planned Shutdown starts and when it ends. This person must be the only person authorized to: inspect the equipment to make sure it is ready for normal operation, verify that operating controls are off, remove the lockout device(s), re-energize the equipment, and notify stakeholders that the Planned Shutdown is over.

Planned Shutdown requirements for the Compressor must include directions for:

- Releasing the air pressure in the system.
- Disconnecting the Compressor from its power source.
- Draining the water in the bottom of the Tank.
- Avoiding contact with hot surfaces.
- Locking out / tagging out the Compressor, per company policies.

Unplanned Shutdown

In the event of an **unplanned** shutdown (tornado hits, full power outage, and so on), BendPak recommends two things at least are done to the Compressor (**if they can be done safely**):

- Disconnect the Compressor from its power source.
- **Carefully** open the Air Discharge port and release the air pressure in the Tank.

Doing these things lessens the chances that the Compressor will restart unexpectedly when the unplanned shutdown is over (which could result in product damage or personal injury) or that the air pressure in the Tank could be released unexpectedly (which could result in personal injury) either during the unplanned shutdown or when it is over.

If it **not** possible to do these two things, then **use extra care** when putting the Compressor back into normal operation when the unplanned shutdown is over.

Maintenance Schedule

Important: The following table is a general Maintenance Schedule based on normal usage of the unit. Your needs may vary based on your specific environment.

Item	Recommended Frequency	Comments
Cleanliness	Daily	Keep the Compressor and the area around it clean. Wipe up any oil/lubricant spills, clean any dirt.
Oil/Lubricant level	Daily	Make sure the amount of oil/lubricant is in the normal range. If the amount is low, add additional. If the amount is high, drain some.
Water	Daily	Drain the Tank daily before startup. The Tank can rust from moisture buildup, which weakens the Tank. Inspect periodically for unsafe conditions such as rust formation and corrosion.
Air pressure in Tank	Daily	Make sure pressure in Tank is not leaking.
Fasteners	Weekly	Make sure the anchor bolts are secure but not too tight.
Anti-Vibration Pads	Weekly	Make sure the anti-vibration pads are securely in place. If not, adjust as necessary.
Environment	Monthly	Make sure environment is free from contamination such as excessive dust in the air or contaminants such as paint. Preferred environment is cool, dry, filtered air.
Belt	Monthly	Make sure the Belt is tight and undamaged. Replace if very loose or damaged. Inspect Belt after the first 30 hours of operation, then monthly after that.
Location	As needed	The air temperature should be 41°F to 100°F (5°C to 38°C); if above or below these values on a consistent basis, consider relocating the Compressor. The humidity should be under 80%; if above this value on a consistent basis, consider relocating the Compressor.
Wiring	Twice Yearly	Have an Electrician check all wiring connections inside the Electrical Box.
Tank	Yearly	Drain the Tank, inspect for rust and corrosion. If found, remove. Do not attempt to repair a damaged Tank; a damaged Tank must be replaced.
All components	Yearly	Take the unit out of service and professionally clean it.
Air Filter	See Comments.	The Air Filter on a new Compressor should be changed after the first 50 hours of use and every 90 days after that; more often in environments with dirty air.

Oil Filter	See Comments.	The Oil Filter on a new Compressor should be changed after the first 50 hours of use and every 90 days after that.
Oil	See Comments.	The Oil on a new Compressor should be cleaned after the first 50 hours of use and every 90 days after that or if the oil becomes milky in color.

⚠ WARNING Do not operate your unit if you find issues; instead, take it out of service, then contact your dealer, email support@bendpak.com, visit bendpak.com/support, or call **(800) 253-2363**, extension 196.

If you require replacement parts, contact BendPak at **(800) 253-2363**, extension 191.

Checking Belt Tension

The Compressor Belt tension should be checked before putting the Compressor into normal operation and periodically after that.

Proper belt tension is determined by pressing on the Belt between the Motor Pulley and Fly Wheel; there should be approximately 1/2 inch of deflection.

1/2" Deflection

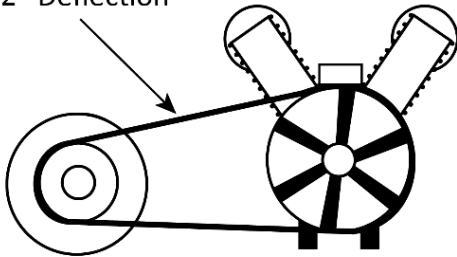

⚠ WARNING Do not perform this procedure until a **Planned Shutdown** has been done and you have taken steps to make sure the Compressor cannot be accidentally re-connected to power until you are done with the procedure.

To check the Belt tension:

1. Adjust the belt tension, loosen the Bolts holding the Motor and slide the Motor on the Base, using a lever if necessary.

⚠ WARNING Do not overtighten the Belt; overtightening the Belt may result in the motor overloading and Belt failure.

2. Retighten the Bolts on the Motor Frame.

Always replace the Belts with the same brand, at the same time; do not replace the Belts independently.

Changing the Air Intake Filter

The Air Intake Filter needs to be changed a number of hours after first putting the Compressor into operation and then again after a specific number of days of operation.

Refer to the **Maintenance Schedule** for details.

⚠ WARNING Do not perform this procedure until a **Planned Shutdown** has been done and you have taken steps to make sure the Compressor cannot be accidentally re-connected to power until you are done with the procedure.

To change the Air Intake Filter:

1. Unscrew the wing nut on the Air Intake, remove the Cover, and then remove the Filter.

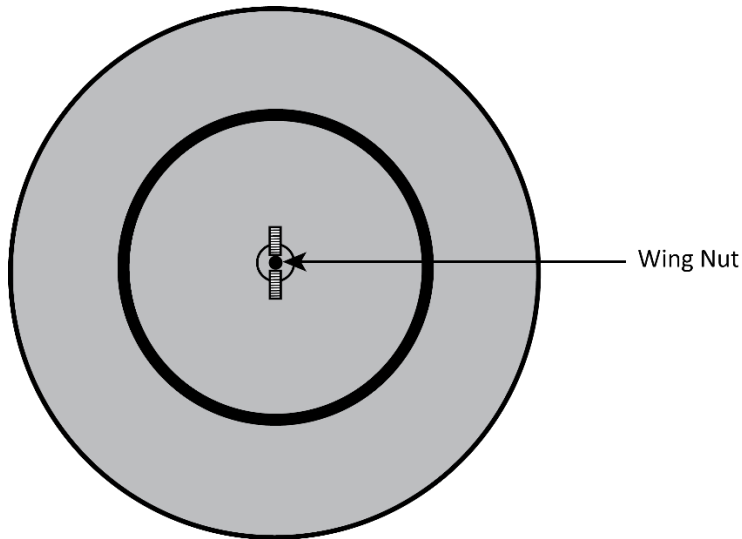

Not drawn to scale. Not all components shown.

2. If one of the thresholds mentioned in the **Maintenance Schedule** has been reached, replace the Filter.
3. If you are just checking the Filter's condition, clean it or replace it based on how dirty it is.
4. Clean the inside of the Air Filter housing.
5. Put the cleaned Filter back or install the new Filter, then replace the Air Intake Cover and secure it.
If you require replacement parts, contact BendPak at **(800) 253-2363**, extension 191.

Changing the Oil Filter

The Oil Filter that came with the Compressor needs to be changed a number of hours after first putting the Compressor into operation. After that, the Oil Filter needs to be changed after a certain number of days of operation.

Refer to the [Maintenance Schedule](#) for details.

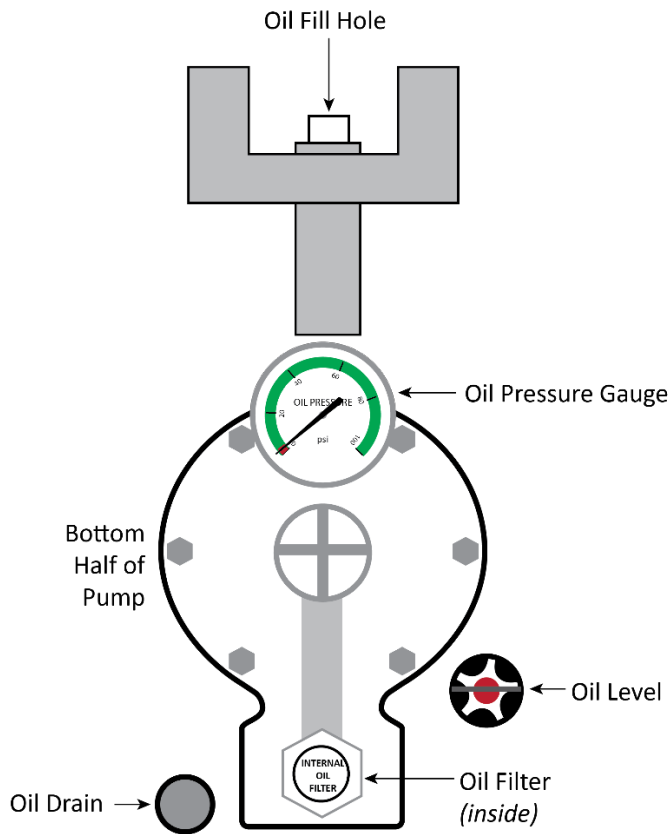

Not drawn to scale. Not all components are shown.

⚠ WARNING Do not perform this procedure until a **Planned Shutdown** has been done and you have taken steps to make sure the Compressor cannot be accidentally re-connected to power until you are done with the procedure.

To change the Oil Filter:

1. Open the Oil Drain and remove the Oil currently in the Pump, then secure the Cap back in place.
If the Oil is clean, you can put it back in when the procedure is over.
2. Using an appropriate tool, unscrew the Oil Filter bolt and take it off.
3. Remove the Oil Filter.
4. If one of the Oil Filter thresholds mentioned in the [Maintenance Schedule](#) has been reached, replace the Oil Filter.
5. If you are just checking the Oil Filter's condition, clean it as necessary, then put back the cleaned Oil Filter or install the new Oil Filter.
6. Re-install the Oil Filter bolt.
7. Re-fill the Pump with Oil.

If you require replacement parts, contact BendPak at **(800) 253-2363**, extension 191.

Changing the Oil

The Oil that came with the Compressor needs to be changed after a number of hours of use after first putting the Compressor into operation. After that, the Oil needs to be changed after a certain number of days of operation.

When you need additional oil, use synthetic, SAE grade 30, piston air compressor oil.

Refer to the **Maintenance Schedule** for details.

⚠ WARNING Do not perform this procedure until a **Planned Shutdown** has been done and you have taken steps to make sure the Compressor cannot be accidentally re-connected to power until you are done with the procedure.

To change the Oil:

1. Open the Oil Drain and remove the Oil currently in the Pump.
2. Close the Oil Drain.
3. Unscrew the Oil Fill Cap and fill it with Oil; do not fill past the halfway mark on the red circle.

Disposal of Used Oil and Oil Filters

Do not dispose of your Air Compressor Oil and Filters by throwing it in the trash or into the environment; it is not regular waste.

Important You must dispose of the oil waste and filters that come from your Air Compressor per all applicable federal, state, and/or local codes. Failure to dispose properly harms the environment and exposes your business to fines and/or legal issues.

Note that appropriate disposal methods include safely storing your waste until you are ready to dispose of it.

You must be proactive and determine the best legal and ethical ways to dispose of this waste.

If you are unclear how to correctly dispose of used fluid:

- Keep each fluid separate and sealed until you dispose of it.
- Take the fluid to a recycling or hazardous waste facility. Cities, counties, and states often support these facilities. Contact them to see if and where. If you can't find a facility, visit earth911.com.

Troubleshooting

This section describes how to troubleshoot your Compressor.

⚠ WARNING: Disconnect the Compressor from power **before performing any maintenance** and take whatever steps are necessary to make sure the unit **cannot be re-energized** while maintenance is being performed on it. The Compressor creates pneumatic energy and uses electrical energy; if your organization has Lockout/Tagout policies, make sure to implement them before troubleshooting the unit.

If your unit is not functioning correctly, you must take it out of service until it is fixed.

Important: All repair work **must** be done by qualified personnel.

Issue	Action to Take
Compressor does not run.	Check the power supply, from inside the Electrical Box to the facility's power system. Make sure breakers are working correctly. Make sure all wiring is connected correctly; wiring can become loose during transport.
Compressor starts and stops frequently.	Check for leakage in the facility's air pressure system. Check for tool that continues to take air. Check settings for start and/or stop thresholds.
Compressor does not reach expected pressure.	Check for leakage in the facility's air pressure system. Check for blockage in Air Filter.
Oil level too low.	Make sure there is enough oil to begin with. If it goes low again, check for an oil leak. Make sure an appropriate oil type is being used.
Excessive vibration or noise.	Make sure anti-vibration pads are in place. Make sure anchor bolts are not too tight (this negates the anti-vibration pads). Check connections to the shop's compressed air piping system. If you have not already done so, consider connecting the Compressor's Air Discharge port directly to a flexible tube; this can reduce vibration between the Compressor and the shop's compressed air piping system.

If you continue to have problems with your unit, contact your dealer, visit [bendpak.com/support](https://www.bendpak.com/support), email support@bendpak.com, or call **(800) 253-2363**, extension 196.

Wiring Diagram

1Ph Wiring Diagram with Magnetic Starter

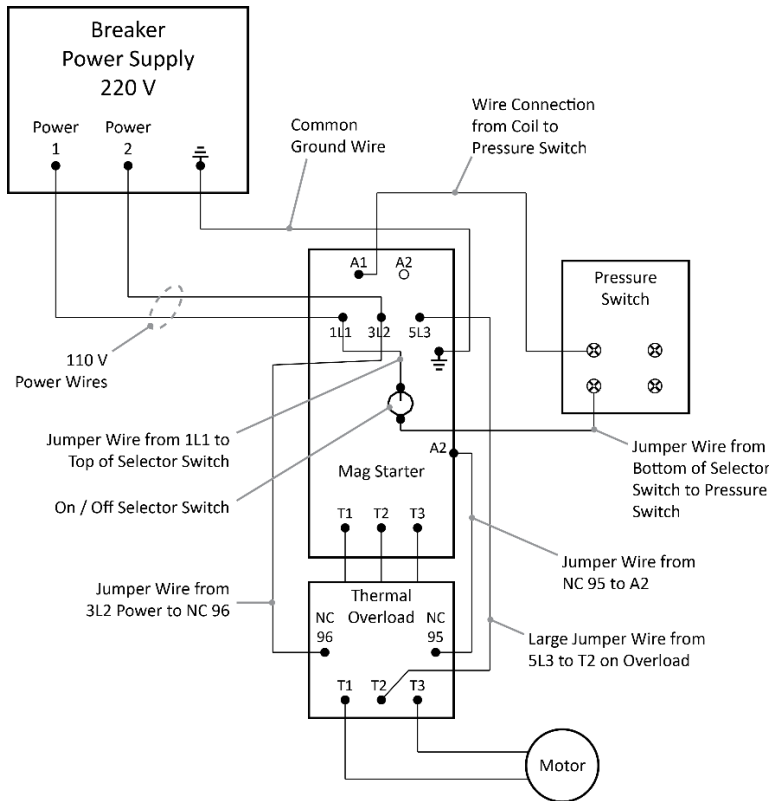

3Ph Wiring Diagram with Magnetic Starter

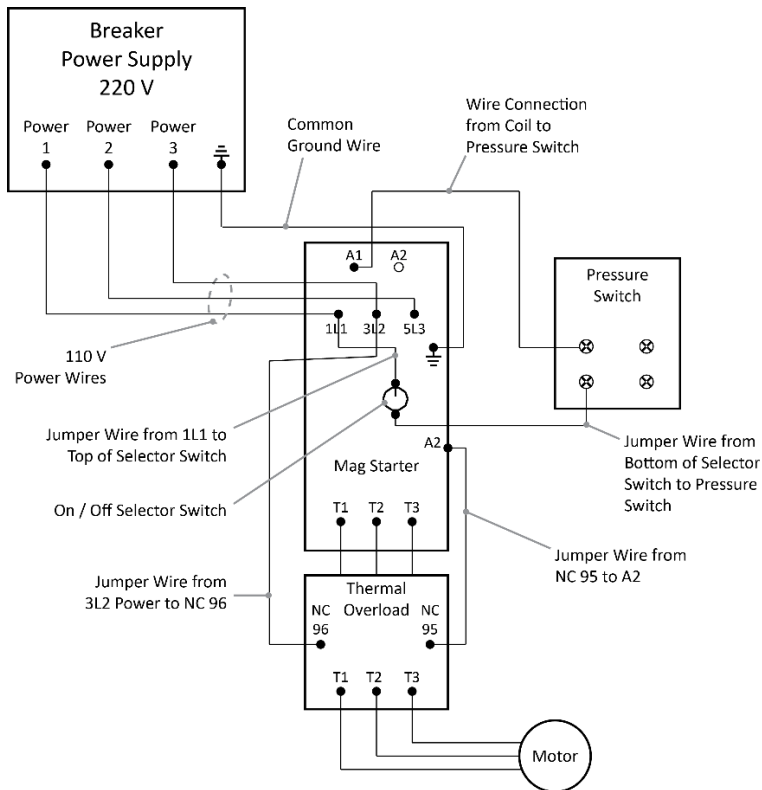

Labels



D not used.

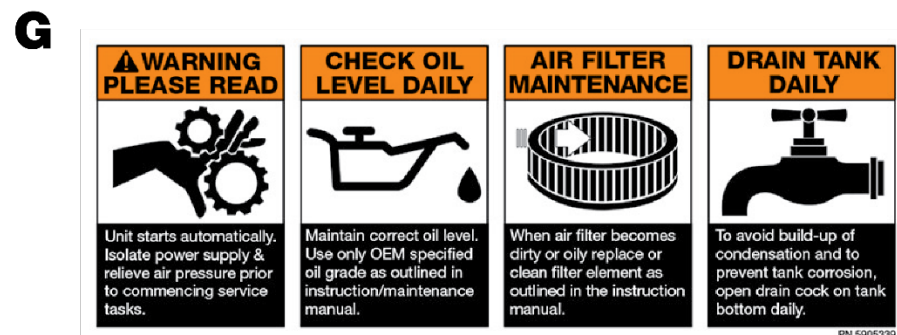
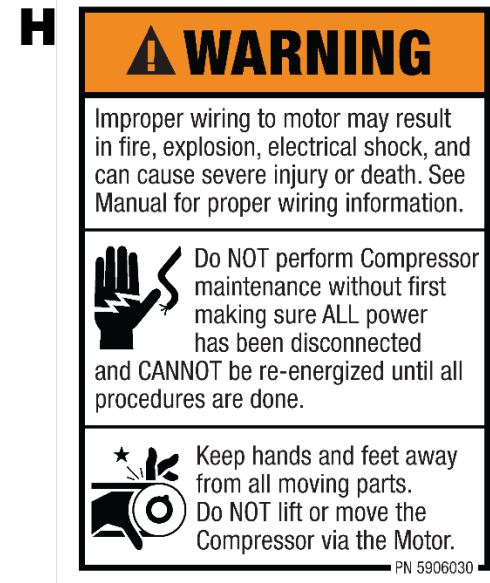

I

⚠ WARNING

Refer to the Manual to determine minimum wire size for your product. All wiring **MUST** be done by a certified Electrician. Damage caused by improper electrical installation is **NOT** covered by the warranty.

PN 5906031

J

⚠ CAUTION ⚠

Clean internal Oil Filter when performing regular maintenance to the Compressor. Failure to do so may result in damage to Pump and is **NOT** covered by the warranty. See Manual for instructions.

PN 5906032

K

⚠ CAUTION

⚡ HIGH VOLTAGE
Disconnect power source before servicing.

PN 5905341

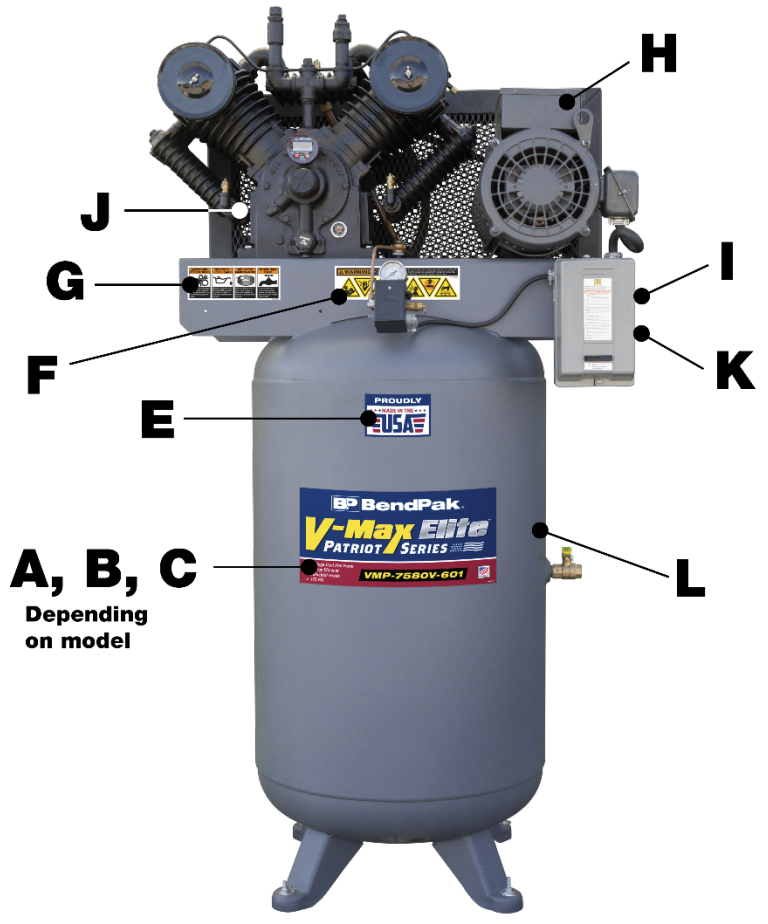

A, B, C
Depending on model

D not used.

Parts Diagram

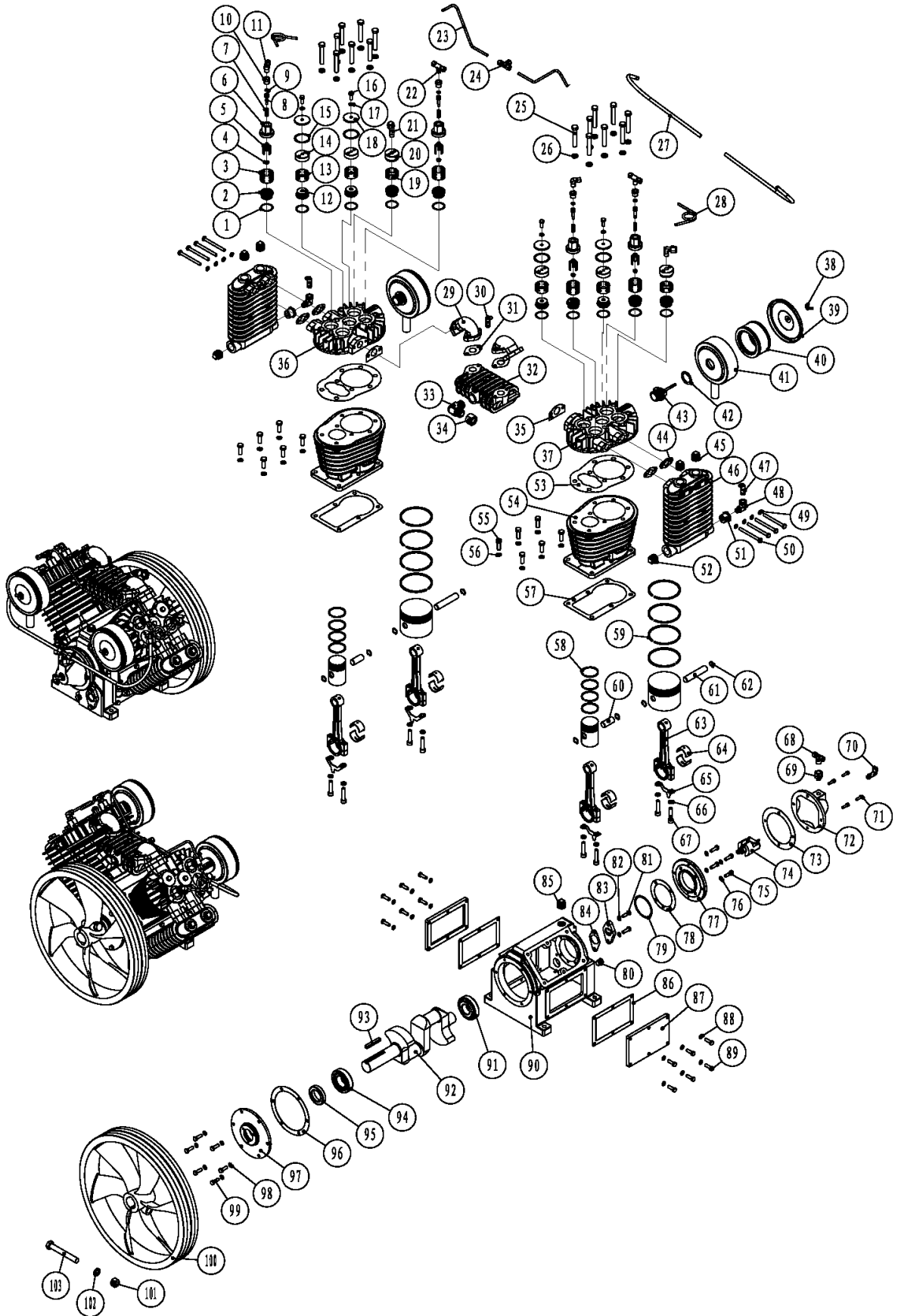

Item #	Part Number	Description	Qty
1	Gasket040	Copper Gasket	10
2	Valve040	Valve Intake	6
3	Retainer004	Retainer, 1.1 long	4
4	Nuts014	Locking Nut, M6-1.0	4
5	Unloader002	Fork, Unloader	4
6	Retainer006	Retainer, Unloader	4
7	Spring001	Spring, Unload, 1.1 long	4
8	Bolt017	Bolt, Unloader, Plunger	4
9	Oring013	Oring, Unloader, Plunger	4
10	Bushing057	Bushing, Brass, 3/8 Male X	4
11	Elbow003	Elbow, 1/4"M to 6 mm Compress	2
12	Valve041	Valve, Exhaust	4
13	Retainer003	Retainer, Exh, .800 medium	4
14	Stopper002	Stopper, Valve, Retainer .650	4
15	Gasket041	Gasket, Valve, Cover	4
16	Bolt012	Hex Bolt, M8-1.25-30 mm	4
17	Washer013	8 mm Copper Washer	4
18	Cover008	Cover, Valve	4
19	Retainer005	Retainer, Int .625 Short	2
20	Stopper001	Stopper, valve, Retainer, .860	2
21	Elbow002	Elbow, 1/4"M to Metric Flare	2
22	Tee001	Tee, 1/4 Male Pipe 6mm Compression	2
23	Line108	Line, Unloader, 6 mm	2
24	Tee002	Tee, 6 mm Compression	1
25	Bolt018	Bolt, M12-1.75-75 mm	16
26	Washer015	Washer, Lock 12 mm	8
27	Line107	Vent, 10 mm, Flared with Nuts	2
28	Line106	Crossover Line, 6 mm	2
29	Elbow001	Elbow, Aftercooler	2
30	Valve008	Safety Valve 200 PSI	1
31	Gasket043	Gasket, Aftercooler	2
32	Cooler009	Aftercooler	1
33	Fitting004	3/4 90 x 5/8 Female	1
34	N/A	Comes with item 33	1
35	Gasket043	Gasket, Head to Aftercooler	2
36	Head010	Head Left	1
37	Head003	Head Right	1
38	Nuts015	Nut, Wing M.6-1.0	2
39	Cover009	Cover, Filter, Air, Intake,	2
40	Filter057	Filter Element, Air, Intake	2
41	Housing027	Base, Filter, Air, Intake	2
42	Gasket086	Gasket, Filter, Air, Intake	2
43	Retainer007	Retainer, Filter, Air, Intake	2
44	Gasket034	Gasket, Intercooler	4
45	Fitting035	Plug, Pipe 3/4	4
46	Cooler002	Intercooler	2
47	Valve055	Safety Valve 70 PSI	2
48	Fitting089	Elbow, 90, 1/4 male to 1/4 female	2
49	Washer013	8 mm Copper Washer	8
50	Bolt019	Bolt, M8-1.25-95 mm	8
51	Fitting016	3/4" Bushing Male x 1/4"	2
52	Fitting035	Plug, Pipe 3/4	2

53	Gasket033	Head Gasket	2
54	Cylinder011	Cylinder	2
55	Bolt016	Hex Bolt, M10-1.5-35 mm	12
56	Washer014	10 mm Copper Washer	12
57	Gasket044	Gasket, CYL, Bottom	2
58	Ring011	Piston Ring High Press.	2
59	Ring012	Piston Ring Low Press.	2
60	Pin010	Wrist Pin High Press.	2
61	Pin008	Wrist Pin Low Press.	2
62	Ring019	Snap Ring, Piston	8
63	Rod010	Rod, Connecting	4
64	Bearing005	Bearing, Rod	4
65	Dipper001	Oil Dipper	4
66	Washer013	8 mm Copper Washer	8
67	Bolt015	Allen Head M10-1.5-50 mm	8
68	Fitting088	T 3/8"M to 10 mm Flare	1
69	Fitting087	Connector, 1/4"M x 3/8"F	1
70	Valve024	Valve Centrif. Unloader	1
71	Bolt014	Allen Bolt, HD M8-1.25-30 mm	4
72	Cover007	Unloader cover	1
73	Gasket046	Gasket Centrif. Housing	1
74	Unloader001	Centrifugal Unloader	1
75	Bolt013	Allen Bolt, HD m8-1.25-30 mm	4
76	Washer013	8mm Copper Washer	4
77	Connector030	Connector, Plate	1
78	Gasket036	Gasket, Brg Housing	1
79	Shim002	Adjust Shim, Crank	2
80	Fitting069	Drain Plug, 3/8 pipe	1
81	Bolt012	Hex Bolt, m8 x 1.25-30 mm	2
82	Washer013	8mm Copper Washer	2
83	Sightglass004	Oil Sight Glass	1
84	Gasket048	Sight Glass Gasket	1
85	Fitting035	Fitting, Plug 3/4"	1
86	Gasket045	Gasket, Access Plate	2
87	Cover006	Side Cover	2
88	Washer013	8mm Copper Washer	12
89	Bolt012	Hex Bolt, M8-1.25-30 mm	12
90	Crankcase007	Crank Case	1
91	Bearing012	Bearing, Crank rear	1
92	Crank007	Crankshaft	1
93	Key002	Key, Flywheel	1
94	Bearing006	Bearing, Crank, Front	1
95	Seal010	Oil Seal, Crankshaft	1
96	Gasket035	Gasket, Front Cover	1
97	Cover005	Front Cover	1
98	Washer013	8mm Copper Washer	6
99	Bolt012	Hex Bolt, M8-1.25-30mm	6
100	Flywheel008	Flywheel	1
101	Nuts013	Hex Nut, 16mm-2.0	1
102	Washer012	Washer, Lock 16 mm	1
103	Bolt011	Hex Bolt, M16-2.0-125 mm	1
104	Piston007	Piston, Low Pressure, Large	2
105	Piston008	Piston, High Pressure, Small	2

Spare Parts

Spare parts available for your Air Compressor include:

Part Number	Description
5323011	Complete Pump Assembly, 7.5 HP Air Compressor
5323020	Pressure Switch, 7.5 HP Air Compressor
5323022	Belt Set, 7.5 HP Air Compressor
5323024	Auto. Drain Valve Assembly, 5 HP & 7.5 Air Compressor
5323025	Air Filter, 5 HP & 7.5 HP Air Compressor
5323026	Belt Set, 10 HP Air Compressor
5323027	Intake Valve, 5 HP and 7.5 HP Air Compressor
5323028	Exhaust Valve, 5 HP and 7.5 HP Air Compressor
5323030	Breather Assembly, 7.5 HP Air Compressor



1645 Lemonwood Drive
Santa Paula, CA 93060 USA