

Ironwood S 115 K

User Manual

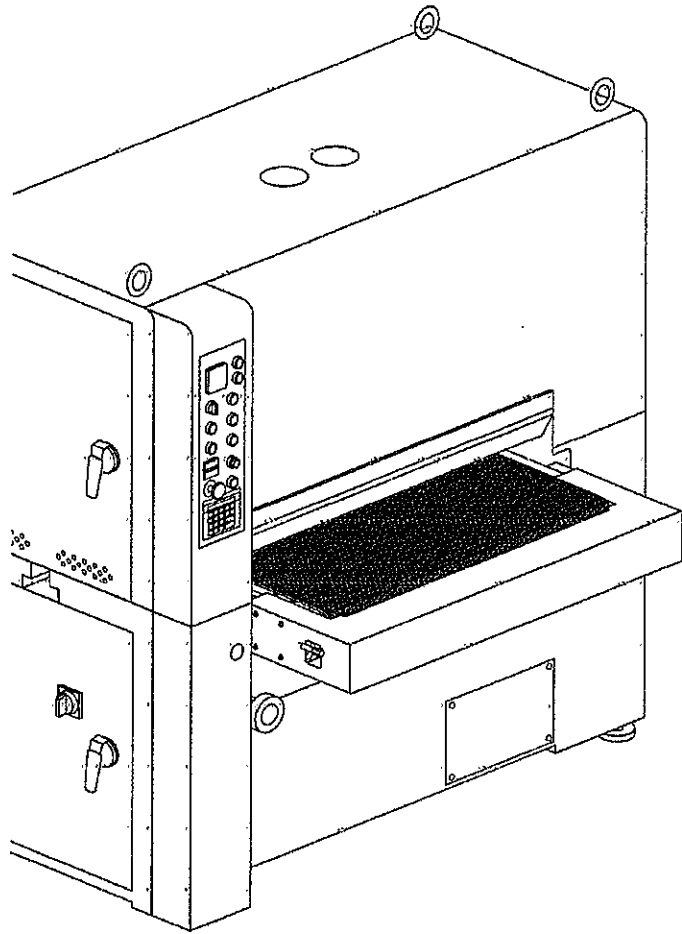

general information. features,
technical specifications, safety considerations.
delivery and installation. inspection,
pre-operation cleaning, **safety.**
operation and adjustments.
machine controls, dressing conveyor belt.
maintenance. inspection,
troubleshooting. electrical, pneumatic.

IRONWOOD

stiles

Table of Contents

1.0	General Information.....	3
1.1	Thank you	
1.2	Before Contacting Stiles	
1.3	Features	
1.4	Intended Use	
1.5	Technical Specifications	
1.6	Safety Considerations	
2.0	Facility Requirements....	6
2.1	Floor	
2.2	Work Space	
2.3	Power	
3.0	Delivery and Installation ...	7
3.1	Receiving the Machine	
3.2	Unpack the Machine	
3.3	Inspection	
3.4	Move Machine to Final Position	
3.5	Remove Machine from Pallet	
3.6	Level	
3.7	Pre-Operation Cleaning	
4.0	Connect to Power.....	10
4.1	Power Connection	
4.2	Air Supply Connection	
5.0	Safety.....	11
6.0	Operation and Adjustments	12
6.1	Machine Controls	
6.2	Check Machine	
6.3	Installing and Replacing Abrasive Belts	
6.4	Abrasive Belt Tracking and Oscillation Speed	
6.5	Adjusting Conveyor Feed Speed	
6.6	Adjusting Pressure / Hold Down Roller Position	
6.7	Adjusting Conveyor Feed Bed	
6.8	Adjusting Sanding Platen Position	
6.9	Platen Maintenance and Replacement	
6.10	Machine Thickness Adjustment	
6.11	Adjusting Conveyor Belt Tension and Tracking	
6.12	Dressing Conveyor Belt	
7.0	Machine Operation.....	21
7.1	Noise Reduction	
7.2	Abrasive Belt Selection and Application	
7.3	Setting Up Machine	
8.0	Maintenance.....	24
8.1	Lubrication	
8.2	Inspection	
8.3	Periodic Maintenance	
9.0	Troubleshooting	25
9.1	Electrical Diagram	
9.2	Pneumatic Diagram	

1.0 General Information

1.1 Thank You!

Thank you for your purchase of the Ironwood S 115 K Widebelt Sander. At Stiles Machinery, our goal is to ensure that you are fully satisfied with your purchase. This manual is provided so that you may properly assemble, operate, and maintain your sander. Should you need help, our team of dedicated service personnel are available to answer your questions and provide any resource recommendations you may need.

Warranty and Support

All Ironwood machines are designed to meet the exacting standards demanded by craftsmen like you. Ironwood machines include a one (1) year parts warranty and two (2) years of free technical support beginning at date of shipment. Warranty service work is not covered by manufacturer's warranty, however, Stiles' service team is available for an additional charge.

1.2 Before Contacting Stiles

Please have your machine model and serial number available when contacting Stiles Machinery with questions. The machine's model and serial number are listed on the metallic plate located on the machine's frame.

For specific information regarding the electrical system and pneumatic supply, please refer to the data that is stamped on the metallic plate and on the markings on the machine.

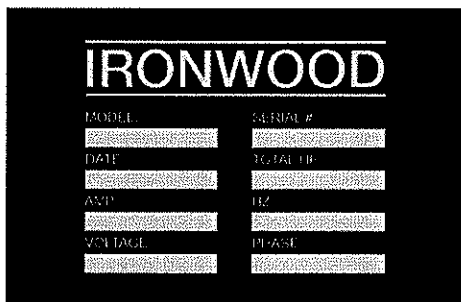

Stiles Technical Support
616.698.6615

Stiles Parts
800.PARTS.80 (800.727.8780)

Website
www.stilesmachinery.com

Machine Model _____

Machine Serial Number _____

1.3 Features

- Robust combination sanding head.
- Heavy duty steel machine base.
- Four heavy-duty jack screws enable precise height adjustment.
- Programmable digital controller has key pad entry for table positioning with 99 program storage.
- Conveniently located and simple controls for easy machine control.
- Poly-V belt drives on all sanding heads.
- Combination head with profiled steel contact roller and sanding pad with 25 hp drive motor.
- 1/2-hp motor raises and lowers table.
- 3 hp feed motor with variable speed controls.
- Variable feed speeds from 13-50 feet per minute.
- Hold rollers on infeed and outfeed of machine.
- 75" abrasive belt length.
- 50" sanding width.
- Automatic conveyor belt tracking.
- Pneumatic disc brakes.

1.4 Intended Use

The Ironwood S 115 K is designed for sanding wood to achieve a desired thickness and/or remove defects, as well as preparing the surface for finishing. Sanding typically follows machining and precedes finishing in the woodworking process.

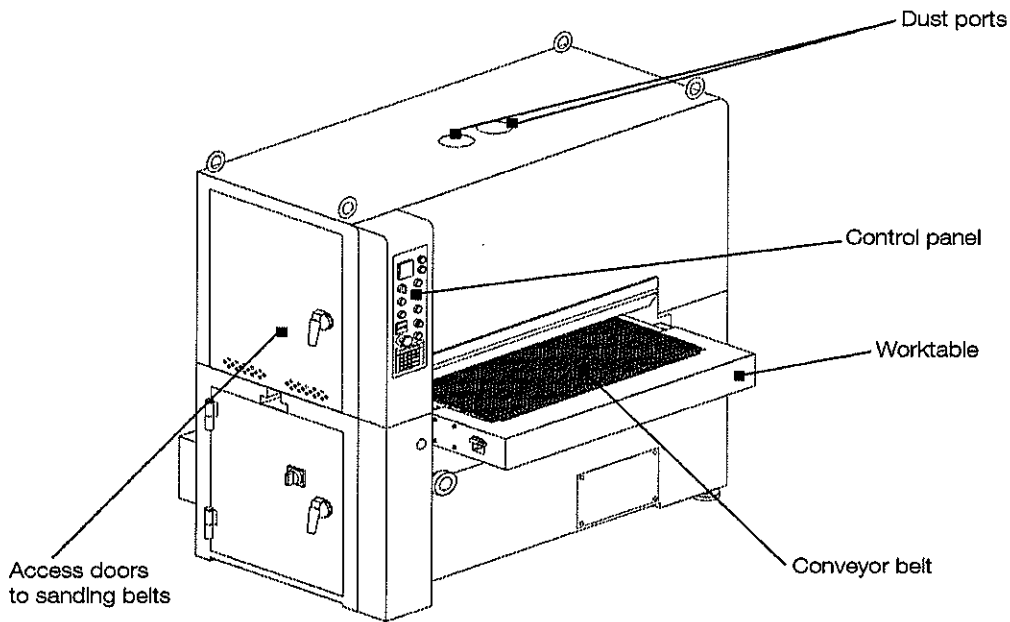

1.5 Technical Specifications

Description	S 115 K
Working width max.	1270 mm (50")
Conveyor belt width	1270 mm (50")
Abrasive belt width	1320 mm (52")
Abrasive belt length	1905 mm (75")
Work piece thickness min.	3 mm (1/8")
Work piece thickness max.	125 mm (4.9")
Work piece length min.	400 mm (15.75")*
Variable conveyor speed	4 – 16 MPM (13 - 52 FPM)
Feed motor	3 HP
Table rise/fall motor	1/2 HP
Combination head – 130mm, profiled steel contact roller with felt pad	25 HP 65 fps belt speed
Electrical connection	230/460v, 3 Phase, 60 Hz
Amperage 230/460v	67.6 @ 230v/ 33.8 @ 460v
Dust collection requirements	1225 CFM
Dust outlet	2 @ 123 mm (5")
Compressed air requirements	90 PSI
Air consumption per cycle	4 CFM
Machine net weight	1,700 kg. (3,750 lbs.)
Machine gross weight	1,820 kg. (4,015 lbs.)
Shipping dimensions (L x W x H)	86" x 69" x 87"

* Shorter workpieces require feeding parts end to end.

1.6 Safety Considerations

For your safety, read these instructions thoroughly before you install and operate this machine. Always have these instructions available at the machine for reference.

Observe all codes and regulations that apply to the installation and operation of this machine.

Familiarize yourself with the safety notices used in this manual.

Keep visitors at a safe distance from the workspace.

Keep children away from this and all machines. Childproof your work area!

CAUTION

If cautions are ignored, personal injury and/or machine damage may result.

WARNING

If warnings are ignored, serious injury or death may result.

Warning Labels

This machine has warning labels attached to ensure safe operation. These warning labels are very important and should be kept clean and never be removed. If warning labels become damaged or lost, contact Stiles Machinery immediately for replacements.

Label 1 Daily Operation Notices before, during and after operation

Label 2 When feeding the workpiece, keep hands clear of feed conveyor and front guarding, pinch point risk

Label 3: Crush/pinch point hazard

Label 4: Compressed air pressure required

Label 5: Machine Voltage

Label 6: Hazardous Voltage. Do not open doors or covers unless machine has come to a complete stop, been shut down, electrical power has been turned off and locked out.

Label 7: Never open machine while running. Machine must come to a complete stop before opening access door.

Label 8: Gearbox lubrication instructions

WARNING

Never use the Ironwood wide belt sander for purposes other than its intended use. Do not modify or remove any guards or other safety features. Improper use or modifications may affect your warranty or result in serious injury or death.





Training

This machine is intended for use by authorized, well-trained operators only.

Do not operate until you have a complete working knowledge of the machine have been properly trained for its safe operation, correct adjustment, and use. All operators should thoroughly read and understand this manual and the workings of this machine prior to operation.

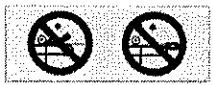
It is essential that all operators be aware of the following:

- The dangers associated with the operation of this machine.
- The use of personal protective equipment for ear and eye protection.
- The proper positioning the operator and operators hands relative to the cutterhead.
- The principles of machine operation.
- The safe handling of the workpiece when sanding.
- The safe stacking of the workpiece before and after sanding.

<p>DAILY OPERATION NOTICES</p> <p>Read and understand the operation manual and all safety labels prior to operation of this machine</p> <p>Before Operation</p> <ol style="list-style-type: none"> 1. Ensure machine is clear of all parts before adjusting height 2. Ensure sanding belts are properly tensioned on machine 3. Ensure sanding belts are running in the correct direction 4. Ensure machine thickness is properly adjusted for part 5. Ensure conveyor is running before adjusting feed speed 6. Ensure air pressure is adequate and adjusted properly 7. Ensure dust collection to machine is running 8. Ensure machine is in operation mode and key is removed prior to operation of machine <p>During Operation</p> <ol style="list-style-type: none"> 1. Do not place hands on conveyor belt 2. Do not turn power to machine off 3. Do not turn compressed air to machine off 4. Ensure there are no nails, staples or metal of any sort contained in the workpiece before sanding workpiece <p>After Operation</p> <ol style="list-style-type: none"> 1. Turn power to machine to off position 2. Clean all dust on the machine, particularly the inner side of conveyor belt and photo eye for belt tracking 3. Operator should record the operation and maintenance conditions of the machine every day <p>Thoroughly following the above daily operation notices may extend the service life of the machine.</p>	 <p>LABEL NO. 2</p>	<p>Working Pressure Range 5-8 kg/cm²</p> <p>LABEL NO. 4</p>	 <p>LABEL NO. 6</p>	 <p>DO NOT OPEN WHILE MACHINE IS RUNNING</p> <p>LABEL NO. 7</p>										
<p>LABEL NO. 1</p>	 <p>LABEL NO. 3</p>	<p>230V</p> <p>LABEL NO. 5</p>	<p>Replace lubricant after the first 300 working hours. Afterward renew it every 1000 working hours. Please use the lubricant of assigned specification.</p> <table border="1"> <thead> <tr> <th>ISO SPEC.</th> <th>Viscosity cst@40°C</th> <th colspan="3">BRAND</th> </tr> </thead> <tbody> <tr> <td>VG-150</td> <td>150</td> <td>Mobilgard 629</td> <td>ESSO Spartan EP 150</td> <td>SHELL Omala 150</td> </tr> </tbody> </table> <p>LABEL NO. 8</p>		ISO SPEC.	Viscosity cst@40°C	BRAND			VG-150	150	Mobilgard 629	ESSO Spartan EP 150	SHELL Omala 150
ISO SPEC.	Viscosity cst@40°C	BRAND												
VG-150	150	Mobilgard 629	ESSO Spartan EP 150	SHELL Omala 150										

2.0 Facility Preparation

Prior to uncrating your machine confirm that your location can accommodate the Ironwood wide belt sander. Follow these guidelines:

2.1 Floor

- The floor must be flat and level.
- Although no special foundations are required, a concrete floor is recommended.
- All floors must have a load-bearing strength suitable for the machine weight of approximately 3,500 pounds (1600 kg.).
- If anchoring the machine to the floor, purchase high quality anchor bolts appropriate to the floor construction and material.

2.2 Work Space

- Provide adequate work space surrounding the machine.
- Provide proper non-glare, overhead lighting.
- Place the machine so that any potential kickback area is not in line with aisles, doorways, or other work and traffic areas.
- Provide adequate dust extraction system.
- The dust extraction system should have a flow rate with a speed of 4,500 feet per minute at 800 CFM.

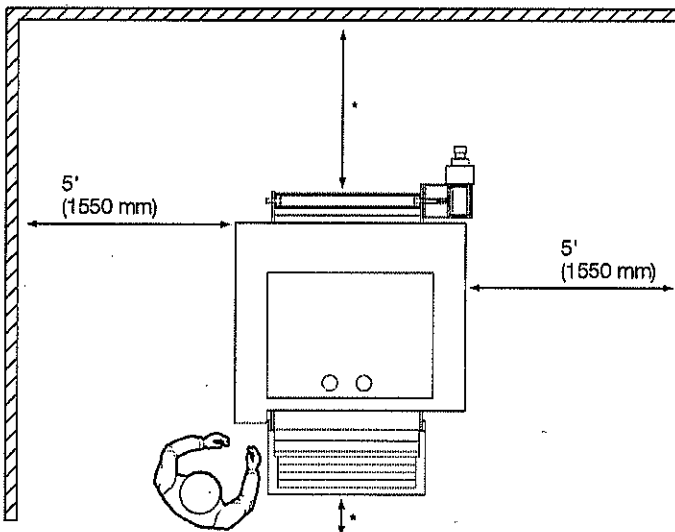

Standard machine clearance requirements*

*Actual clearance requirements may vary depending on length of material to be sanded. Minimum free space on outfeed of machine must be at least 500mm greater than the maximum length of workpiece to be sanded.

Dust port layout

- 2 ports @ 123mm each (5")

2.3 Power

⚠ WARNING

A licensed electrician must connect the Ironwood Wide Belt Sander to the building power source.

- Do not use extension cords.
- Be sure that the electrical current of the power source is of the same characteristics as the electrical system supplied with your machine. If other machine voltage capabilities are required, contact Stiles Machinery.

S 115 K	
Sanding Head 1	25hp
Feed Motor	3hp
Table Lift Motor	1/2hp.
Power	230 V / 460 V (3 phase)
Total Required Amperage	67.6 Amps / 33.8 Amps

- In case of incoming main voltage fluctuations or more than +/- 5% of machine connected voltage, including phase to ground, a voltage stabilizer must be installed by the customer on the incoming power connection.
- Ensure the machine is protected with an external over-current protective device per your local electrical codes.
- Electrical equipment operating conditions:
- Air temperatures between +41F (+5°C) and +113F (+45°C).
- Relative humidity not to exceed 50% at a maximum temperature of +113F (+45°C).
- Electrical equipment is designed and protected to withstand the effects of transportation and storage temperatures within a range of -13°F (-25°C) to +131°F (+55°C), and for short periods of time not exceeding 24 hours at up to +158F (+70°C).
- Ensure connection to factory ground system is wired correctly (IAW local electrical codes and NEC) and not connected to any electro magnetic interference source such as welders.

3.0 Delivery and Installation

3.1 Receiving Your Machine

You will be contacted to arrange delivery. Your machine will be delivered by truck to your location. If there is no loading dock, be sure that you have informed the carrier in advance and have a plan in place for unloading.

Before accepting the machine and signing the bill of lading from carrier, please inspect crating and machine condition, note potential damage on the bill of lading, take pictures of potential damage, and contact Stiles Machinery immediately.

The machine will arrive fully crated and secured to a pallet. Use a fork lift to move the machine on its pallet as close to its final position as possible. A rigger may be required.

If you do not intend to install the Ironwood Shaper immediately after delivery, store it in a protected, cool, and dry location.

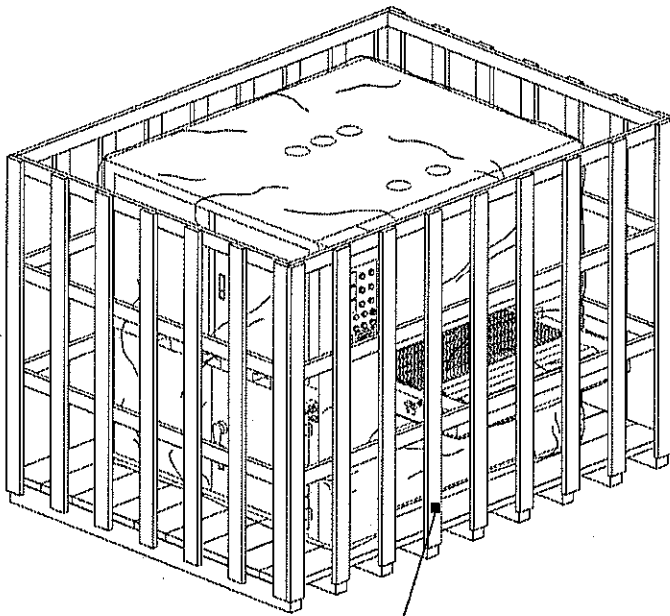

The machine arrives fully crated and secured to the pallet.

3.2 Unpack the Machine

TOOLS REQUIRED:

- Hammer
- Crowbar

Unpack as follows:

Do not remove the machine from the pallet.

1. Remove and save all paperwork attached to the outside of the crate.
2. Remove the crating, starting with the top, then remove the four sides. Use caution to avoid personal injury and prevent damage to the machine's finish.
3. Remove the protective plastic from the machine, starting at the bottom.

Do not remove the protective paper that covers the feed conveyor.

4. Remove the infeed roller table attached to the skid and attach to the machine. There are 4 screws located in the left side, and 3 screws located in the right side of the feed conveyor bed. Remove and install infeed roller table.

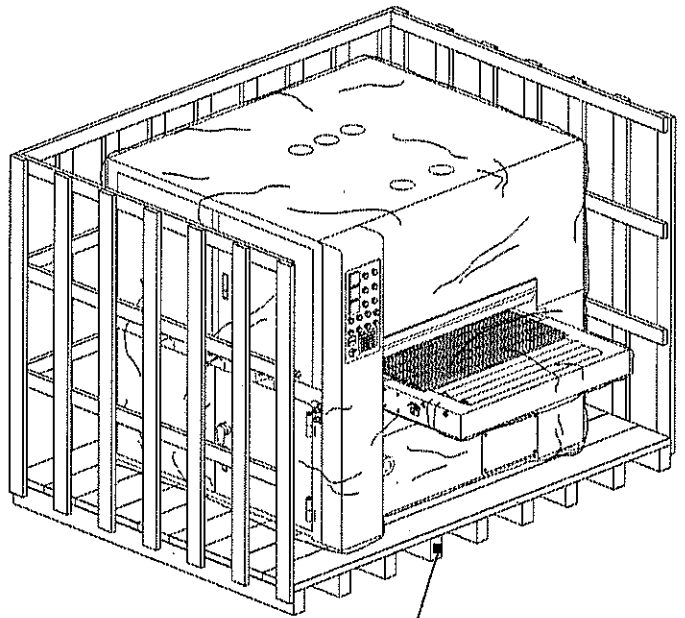

Do not remove the machine from the pallet while uncrating.

5. Open the side access doors. There is a door key located inside the toolbox. There are access doors on either side of the machine.
6. Check inside the access doors for any hardware or accessories. Remove the hardware, accessories, and a tool kit that are shipped with the machine. If additional accessories are ordered, they may be delivered separately.
7. Close and lock the side access doors.

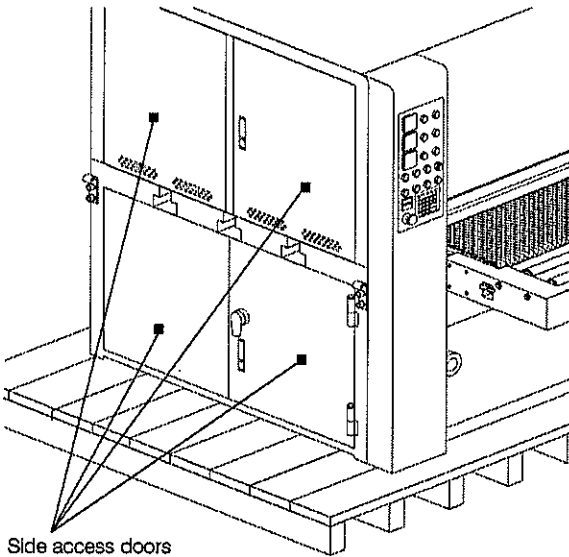

3.3 Inspection

Save all containers and packing materials until you are satisfied that your machine has arrived in good condition. If you discover the machine is damaged after you've signed for delivery, immediately call Stiles Customer Service at 616.698.7500.

When you are completely satisfied with the condition of your equipment, you should inventory its parts.

Open and check the contents of all containers to ensure all tools, hardware, and accessories are included. The tool kit should contain the following items:

1. 4-piece open end wrench set
2. Short handle Allen wrench set
3. T-handle platen pulling tool
4. Grease gun
5. Cabinet handle key for locking / unlocking cabinet access doors
6. Four (4) leveling pads
7. Four (4) leveling bolts with nut
8. Incoming air fitting
9. Paint (2 color set)
10. User manual

3.4 Move Machine to Final Position

Be sure the site is properly prepared. Refer to section 2.0 for details.

Be sure the cabinet doors are closed and locked before transporting.

TOOLS REQUIRED:

- Fork lift or crane
- Lifting straps

Use a forklift or crane to move the machine on its pallet to its final location. When using a crane, use straps connected to the rigging hooks and a spreader bar. Do not triangulate on the top of the machine. Machine may also be moved using a forklift, however, if using a fork lift, make sure fork travel is clear of any obstacles and forks are well supported under machine frame. Forklift must have 3,500 lb capacity.

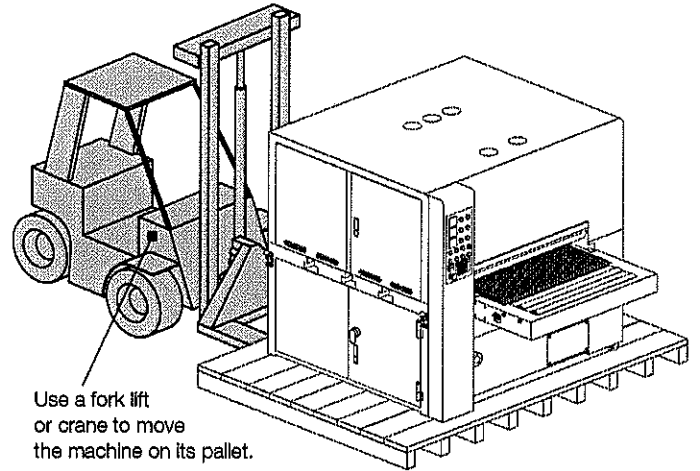

Machine must be picked using a suitable forklift, picked from below, or a lifting straps with a spreader bar.

3.5 Remove Machine from Pallet

⚠ CAUTION

The Ironwood S 115 K Wide Belt Sander weighs approximately 3,500 pounds. For this procedure, we recommend using a fork lift or crane.

TOOLS REQUIRED:

- Adjustable wrench
- Machine-door key

When the machine has been placed at its final location, carefully remove the machine from the pallet.

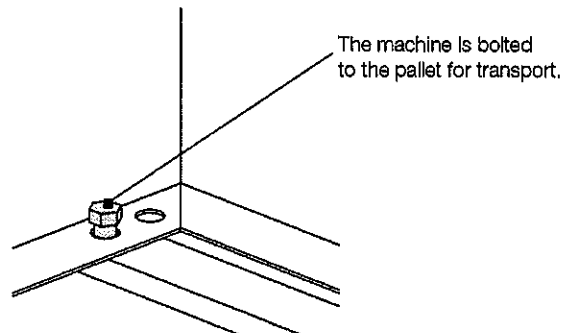

1. From inside the cabinet, remove the four nuts that secure the machine to the pallet at the interior corners.
2. Lift the machine from the pallet by one of 2 methods:
 - a. Pick up with a fork lift from underneath the machine (ensuring forks are supported underneath the machine frame. There are openings in the bottom of the machine frame that must be observed to safely pick up machine with a forklift.)
 - b. With a fork lift or crane, use a hoist hook and lift strap secured to the hooks on the side of the machine to move and place the machine. A spreader bar must be used. Do not triangulate on the top of the machine.
3. Carefully slide or set the machine into final position.

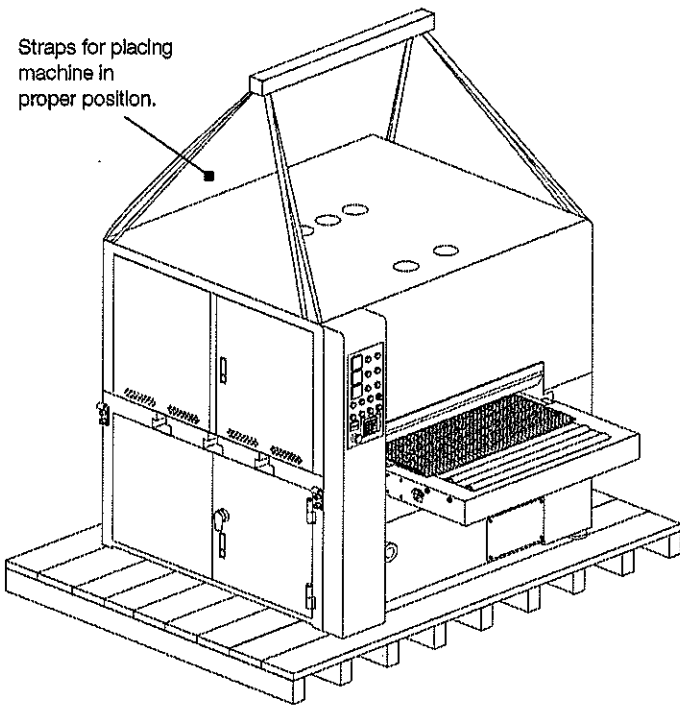

3.6 Level

TOOLS REQUIRED:

- Bubble Level
- Adjustable wrench

Use a bubble level along the length and width of the machine frame to check for level. Use an adjustable wrench to adjust leveling bolts to level machine.

Level infeed rollers on infeed roller table so they are level, or slightly below the plane of the feed conveyor.

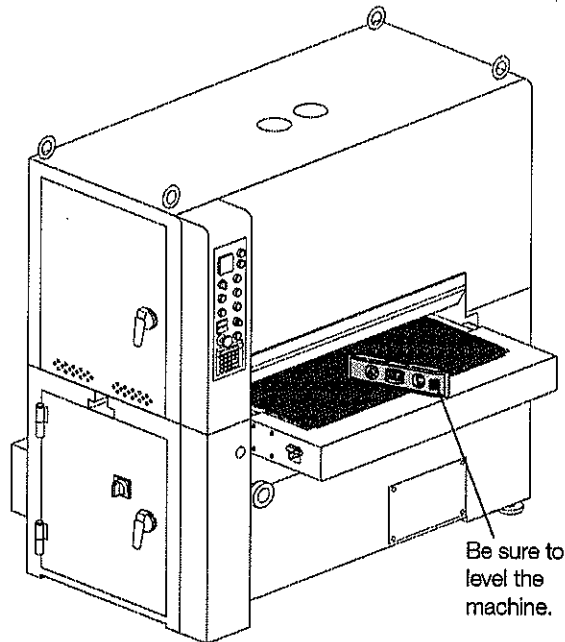

3.7 Pre-Operation Cleaning

⚠ WARNING

Use proper cleaning agents and methods described below. Do not use gasoline or other petroleum-based solvents. Risk of fire or explosion.

Steel Contact Roller, Tensioning Rollers, and Bare Metal Surfaces

Remove the protective oil coating with a soft cloth and nonflammable degreasing agent, such as Simple Green or other citrus-based cleaners to carefully clean off all grease. Do not use abrasive pads.

Machine Feed Conveyor Bed

Remove and discard any protective materials from the top of the feed conveyor. Use a soft cloth and nonflammable degreasing agent, such as Simple Green or other citrus-based cleaners to carefully clean off all grease from the metal edges of the conveyor bed surrounding the feed conveyor belt. Do not use abrasive pads.

4.0 Connect to Power and Air

4.1 Power Connection

- Voltage – Steady state voltage +/- 5% of nominal voltage.
- Machine needs steady voltage at all times.

NOTE: In case of incoming main voltage fluctuations of more than +/- 5% of machine connected voltage, including phase to ground, a voltage stabilizer must be installed by the customer on the incoming power connection.

⚠ WARNING

Before connecting power to the machine, make sure all screws and fasteners are tightened, all mechanical functions work freely, and the contact drums and rollers turn freely.

⚠ WARNING

All connections to electrical power should be completed by a licensed electrician.

Before connecting to a power source, confirm that the electrical current of the power source is the same as the electrical system supplied with your machine. Ensure the machine is protected with an external over current protective device per your local regulating authorities.

Machine must be properly grounded to prevent electric shock. Never connect the yellow/green wire to a live terminal.

Once connected to power source, terminals are electrified even while the power switch is off.

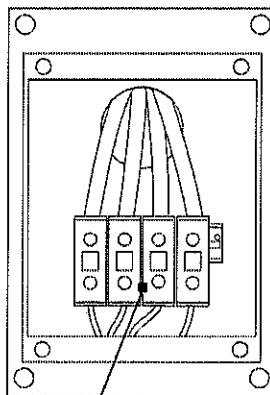

Proper wiring inside terminal box.

To connect power source to the machine:

1. Remove screws and remove terminal box cover.
2. Insert source power cables through opening of terminal box and secure.
3. Connect the three power cables to terminals L1, L2 and L3, and the yellow/green ground wire to ground terminal.
4. Replace the terminal box cover and tighten screws.

NOTE: Before operating machine, machine phasing needs to be tested. See section 6.0 for instructions on phase testing.

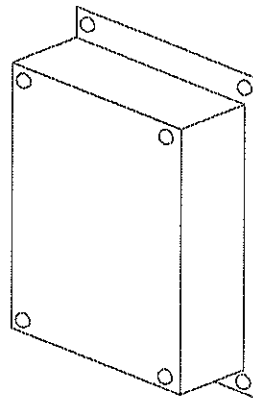

Remove terminal box covers.

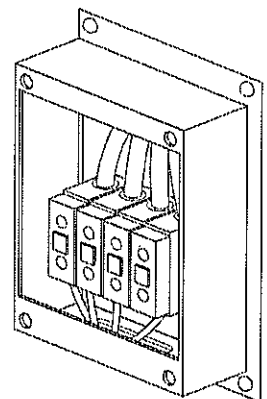

Connect power and grounding wires.

⚠ WARNING

Always shut off power at source before removing terminal box cover. Failure to comply with this action may result in electric shock.

⚠ CAUTION

We have covered some basic electrical requirements for the safe installation of your machine. These requirements may not cover all installation requirements. You must confirm that your particular electrical configuration complies with all local codes. Ensure compliance by checking with your local municipality and a licensed electrician.

4.2 Air Supply Connection

An air filter regulator unit is supplied with the machine to connect the machine to the air supply and to regulate the air pressure for normal machine operation. The air pressure regulator should be set to 80-90 psi (5-6 bar) for normal machine operation. To adjust the machine air pressure:

1. Pull up on the outer ring of the regulator knob.
2. Turn the regulator knob to adjust the pressure to the desired setting.

NOTE: pressure gauge is located on the front left panel of machine control for easy access and inspection during machine operation. Air pressure should not exceed 120 psi (8 bar).

⚠ CAUTION

The air pressure should not be lower than 60 psi (4 bar). If pressure is below 60 psi, machine performance can be affected and potential damage could occur.

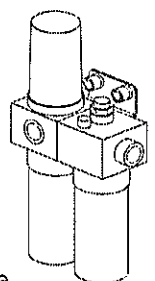

5.0 Safety

WARNING

Like all power equipment, there is danger associated with the Ironwood Wide Belt Sanders. Use caution and follow all safety instructions. Take every precaution to protect yourself, others around you, and the machine itself from improper use. Safety is a combination of common sense, training, and being alert at all times while operating your machine. If instructions, warnings, and cautions, are not followed, serious personal injury or death may occur.

EYE PROTECTION: Always wear approved safety glasses, or a face shield when operating this machine. Only use eye protection that meets or exceeds the standards of the American National Standards Institute (ANSI).

EAR PROTECTION: Always wear ear protection during machine operation.

DRESS CODE: Do not wear loose clothing, neckties, jewelry, or gloves that can get caught in moving parts. Confine long hair and keep sleeves above the elbow.

ELECTRICAL GROUNDING: Your machine must be electrically grounded. If a cord and plug are used, make certain the machine is properly grounded. Follow the grounding procedure indicated by the National Electric Code and local regulating authorities. Keep power tools in dry areas and free from moisture.

GUARDS: Make certain that machine guards are in place and in good working order. Machine should not be run if guards are not in place.

TOOLING AND ACCESSORIES: Use only recommended tooling and accessories. Improper tooling and accessories may cause damage to your machine or personal injury. Always run at the correct speed and feed rate. Never force a tool or accessory to perform a job for which it was not designed. Maintain your tools and accessories. Knives should be sharp and clean for safe and optimal performance. Follow instructions for lubricating and changing tooling and accessories.

POWER: On machines equipped with a manual starter, make sure that the starter is in an "OFF" position before connecting power to machine or electrical maintenance.

Make certain the machine is either unplugged or electrically disconnected and locked out when performing all other maintenance, cleaning, or machine adjustments. Never leave the machine running unattended. Always turn the power off and stay by the machine until the cutterhead comes to a complete stop.

HOUSEKEEPING: Before turning machine on, remove all extra items on or around the machine. Keep the work area clean and free of scrap material, sawdust and other debris to minimize the danger of slipping. Use compressed air or a brush to remove chips or debris. NEVER use your hands. Do not blow compressed air in electrical cabinet. If dirty, vacuum dirt out with vacuum.

6.0 Operation and Adjustments

⚠ WARNING

Do not attempt to operate machine if you are not completely familiar with its operation. Obtain immediate advice from a supervisor, instructor, or other qualified personnel.

Use of this machine requires that you give your work your undivided attention, and careless acts or not paying close attention to work being performed may result in serious injury to yourself and/or others. Never operate this or any machine under the influence of drugs, alcohol, or any medication that may impair judgement.

Dust created by this machine may be harmful to your health.

Your risks from exposure may vary. Always work in a well-ventilated area and wear safety approved, protective dust masks specifically designed to filter out microscopic particles. Utilize wood dust collection systems appropriate to your machine type.

6.1 Machine Controls

Push-button controls are conveniently located on the front upper left side of the machine. A feed speed control is located on the back lower right side of the machine. Familiarize yourself with the controls before operating the machine.

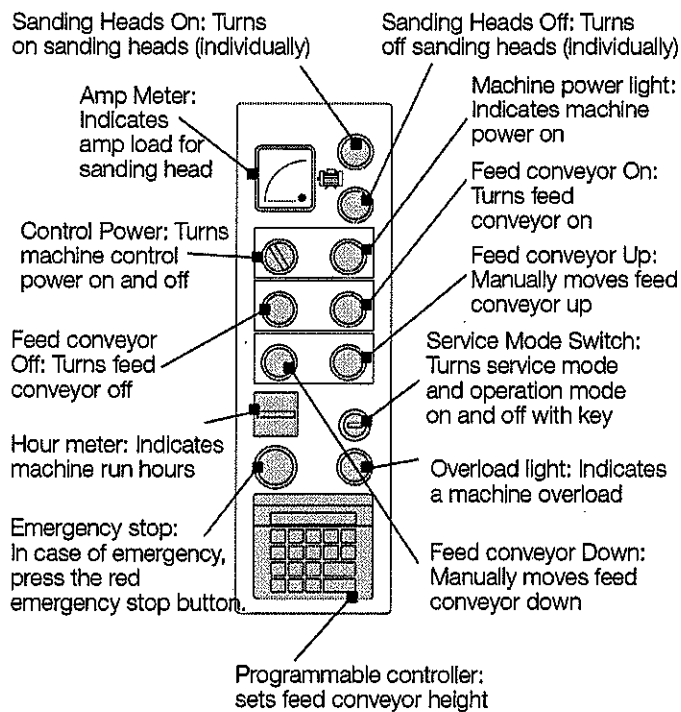

6.2 Check Machine

Prior to machine set-up or performing any adjustments, repair work, or trouble shooting, it is very important to check the applicable safety functions to ensure they are all in proper working condition.

Before operating or adjusting the machine, follow these steps.

⚠ WARNING

Disconnect the machine from its power source before working on machine.

Step 1: Check the Sanding Heads and Abrasive Belts

⚠ CAUTION

The abrasive are very sharp. Handle with extreme care when inspecting or replacing.

The sanding heads are designed for 50" wide by 75" abrasive sanding belts.

The sanding heads and abrasive belts should be inspected before each operation. Be sure the sanding heads can rotate freely and the abrasive sanding belts are clean, sharp and free of any defects (tears, holes, splits, cuts). Overly worn or loaded sanding belts may reduce sanding quality, will wear machine and will draw excess power load.

Step 2: Check Machine Phase Rotation

Machine phase rotation must be checked prior to operation of machine.

To Check Phase Rotation:

1. Ensure feed conveyor on machine is clear and nothing is resting on top of feed conveyor.
2. Turn Main Power to Machine On.
3. Turn Control power to machine On.
4. Press feed conveyor Down button. If feed conveyor goes down as intended, phase rotation is correct. If feed conveyor goes up when pressing the feed conveyor down button, machine phasing must be changed. If phasing needs to be changed, follow steps below. If phasing is correct, proceed to step 3.

⚠ WARNING

Always shut off power at source before removing terminal box cover. Failure to comply with this action may result in electric shock.

All connections to electrical power should be completed by a licensed electrician.

Once connected to power source, terminals are electrified even while the power switch is off.

To Change Phasing:

1. Shut off main power from the source to the machine.
2. Remove terminal box cover.
3. With voltage meter, test in coming power to ensure power to machine is off.
4. Disconnect two of the power legs (L1 and L2 for example).
5. Wire L1 in the terminal where L2 was removed and ensure screw is fastened.
6. Wire L2 in the terminal where L1 was removed and ensure screw is fastened.
7. Replace terminal box cover.
8. Turn on main power from the source to the machine.
9. Repeat phase rotation check as listed above to ensure phasing is correct.

Step 3: Machine Alignment

For accurate sanding, the conveyor table must be parallel to the sanding heads and the sanding heads must be parallel to one another. Machine is aligned at the factory. Do not adjust conveyor table parallelism unless you are experiencing sanding issues. Call Stiles Machinery Technical Support at 616.698.6615 prior to attempting any machine adjustments.

Hold down rollers should be positioned in proper relation to the sanding heads. Use a dial indicator to check positions and make adjustments. Hold down rollers should have 0.5 – 1mm of down pressure on the parts (and be set below the sanding heads to accommodate this).

To test for parallelism between conveyor table and sanding heads and hold down roller height, remove the sanding belts and place a dial indicator under each side of the roller or contact drum. Raise the table manually until the gauge is in contact with the appropriate roller. Test the thickness on either side of the roller. Check multiple points on multiple rollers to determine if the rollers are out of alignment or the table is out of parallelism. Typical allowable tolerance is +/- 0.1mm over machine width.

Step 4: Check Poly-v Belt Tension

Each sanding head includes a poly-v drive belt. It is important to maintain proper belt tension to the sanding heads. New belts must be checked the first 3 days of operation until they are seated. After machine has been in operation, belt tension should be checked periodically. If belts are not properly tensioned, abnormal noise or vibration may result and sanding performance may diminish.

Drive belts should have approximately 1 cm (½" or less) deflection.

If belts need to be tensioned, lower the adjustment bracket to increase belt tension as follows:

1. Disconnect sander from power source.
2. Loosen the lower lock nut .
3. Adjust the lower adjustment nut.
4. Loosen the top lock nut .
5. Tighten down the top adjustment nut until proper tension is achieved and lock and top and bottom adjustment nut are in firm contact with the adjustment bracket.
6. Tighten top and bottom lock nut to secure.

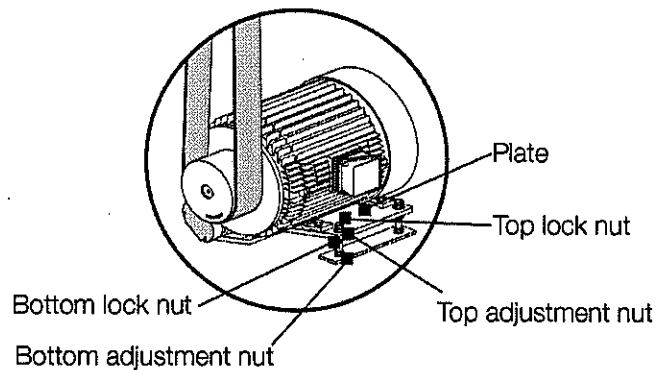

⚠ CAUTION

Never place the v-belt under excessive strain, as this can overload the motor and damage the bearings, sanding head, or belt.

6.3 Installing and Replacing Abrasive Belts

CAUTION

Before installing sanding belts, check abrasive belt for cutting direction. Make sure the cutting direction of the abrasive belt matches the rotation direction of the machine. Certain abrasive belts are intended to run in only one direction.

Before installing abrasive belts on the machine for the first time, ensure the belt breakage limit switch located on the back side of each sanding head is located in between the two adjustment points.

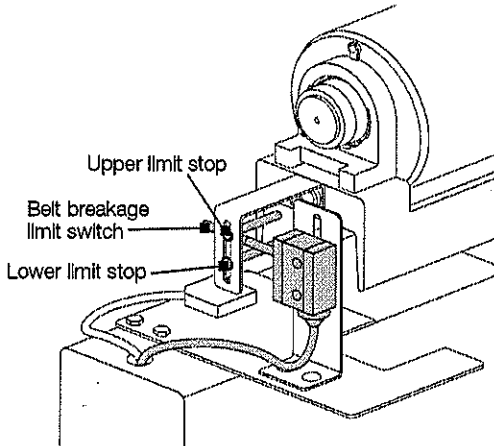

To install or replace abrasive sanding belts, proceed as follows:

1. Machine should be off.
2. Open abrasive belt access door (upper left access doors).
3. Turn the belt tensioning switch to Off position.
4. Unlock and remove sanding head lock by sliding head lock out of locking groove.
5. Inspect the sanding belt for defects such as torn or rough edges, splits, holes or cuts. Do not use a belt if it is damaged in any way.
6. Install the new abrasive belt by loading the abrasive belt starting with the top roller. Use the abrasive belt loading assist to align the belt, then load the belt over the lower roller/s. Slide the abrasive belt onto the rollers.
7. Center the belts on the rollers while avoiding contact with the over travel limit switch fingers. Abrasive belt tracking photo eye will turn green when in belt is in position if machine is on.

NOTE: machine will not start if belt over travel limit switch is activated.

8. Re-install the head lock by sliding back into locking groove and securely tightening locking lever.
9. Turn the belt tensioning switch to On position to tension belt.

NOTE: When the machine is not in operation, it is suggested to release the sanding belt tension completely to preserve the abrasive belts and prevent stretching.

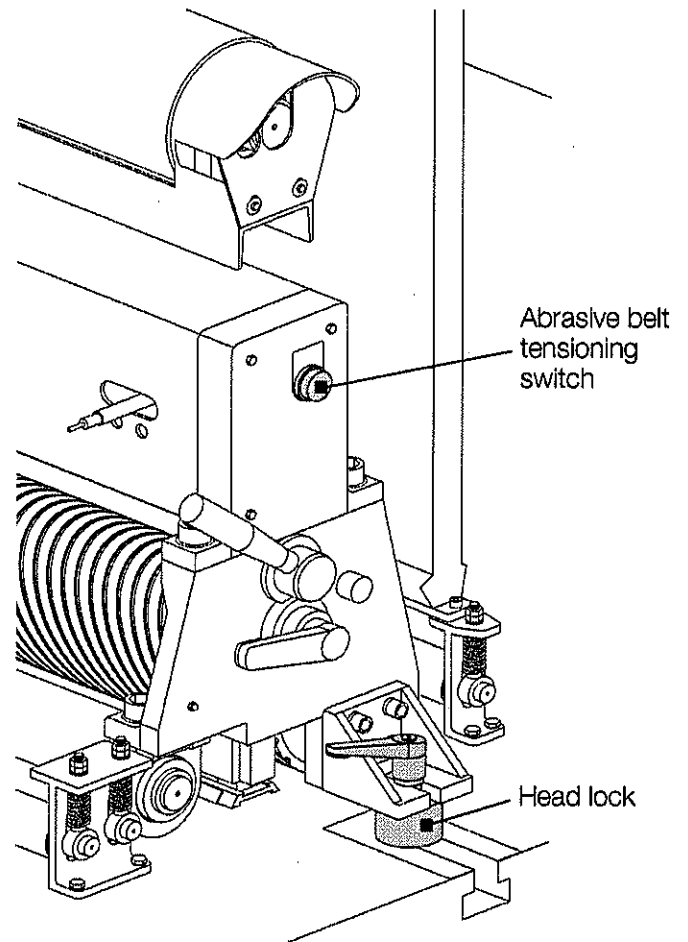

6.4 Abrasive Belt Tracking and Oscillation Speed

The abrasive belt should oscillate back and forth (left and right) without running off the rollers. If the belt is not tracking properly, the belt will contact the over travel limit switches and will stop the machine.

Oscillation settings have been set at the factory; however, oscillation may need to be adjusted when a new sanding belt is installed to get abrasive belt to properly track. Every sanding belt is slightly different and may have a slight difference in length from left side to right side of the abrasive belt. This slight length difference may result in incorrect tracking and may require tracking adjustments. If this occurs, oscillation speed and belt trimming can be adjusted to achieve optimal abrasive belt tracking. Oscillation motion of abrasive belt is actuated by an air cylinder. An electronic photo eye is what signals the actuation from left to right of the air cylinder. Do not adjust photo eye sensitivity or problems may result with belt tracking.

⚠ WARNING

To adjust oscillation speed, machine must be operating with access door open. Use extreme caution when operating machine with access door open and never touch any moving parts or severe injury could result.

To adjust oscillation speed:

1. Turn machine on.
2. Turn service mode switch to service mode. This will allow the machine to run while the access door is open. A key is required to turn the service mode switch. The back access door must be opened.
3. Ensure belt is properly loaded and tensioned.
4. Turn the head on from the controller.
5. Loosen the fixing nut on the base of the regulator valves.
6. Turn the speed regulator valve clockwise for reducing the oscillation speed, or counter clockwise for increasing the oscillation speed. The belt oscillation from left to right should be equal. If belt is not tracking evenly, see note below for optimal belt tracking and belt trimming adjustment. If belt is tracking well, continue to step 7.
7. Tighten the fixing nut on the base of the regulator valves.
8. Close the access doors.
9. Turn the service mode switch to operation mode and remove the key.

NOTE: Optimal belt tracking is when belt oscillates back and forth at the same speed (i.e. oscillation time to right takes 2 seconds, oscillation time to left takes 2 seconds). If sanding belt moves one direction quickly and the other direction slowly, oscillation adjustments are necessary. Belt trimming can also help to center sanding belt to make the oscillation more consistent.

To Adjust Belt Trimming:

1. Open back access door.
2. Adjust long nut on belt tracking cylinder to lengthen or shorten cylinder stroke.

Always ensure access doors are closed and locked and service mode switch is placed in the operation mode position before running production.

6.5 Adjusting Conveyor Feed Speed

The machine conveyor feed speed is variable and can be adjusted for sanding various wood materials or depending on the sanding application. Depending upon material type, feed speed and abrasive grit will determine safe stock removal.

⚠ CAUTION

Attempting to remove too much material in one pass could result in damage to machine or abrasive belts.

⚠ CAUTION

Never adjust feed speed unless the feed conveyor is running. Feed speed adjustment when feed conveyor is stopped will damage the feed speed adjustment device.

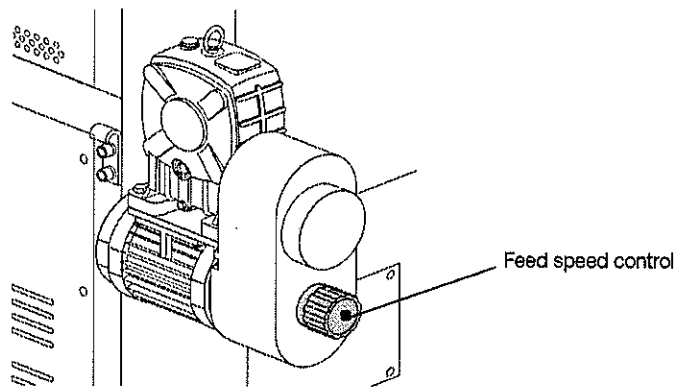

To Adjust Feed Speed:

1. Turn machine on.
2. Turn feed conveyor on.
3. Adjust conveyor feed speed by turning adjustment knob while conveyor is running.

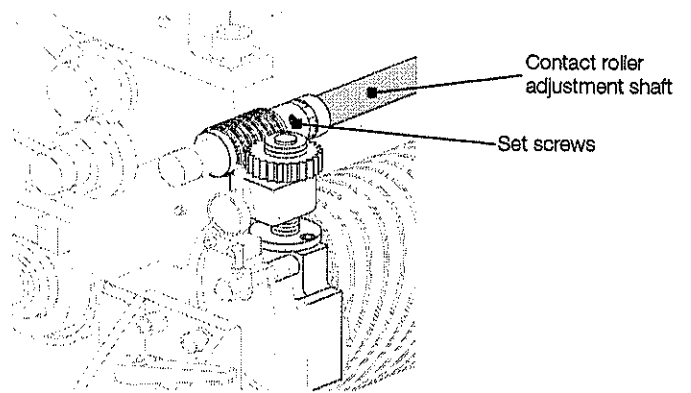
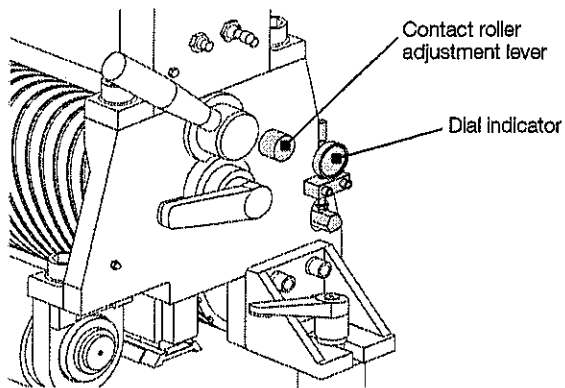

To Adjust Contact Rollers:

1. Open upper left side access doors.
2. Use adjustment handle or wrench to turn adjustment lever.
3. Turn the adjustment lever clockwise to raise the contact drum. Turn the adjustment lever counter-clockwise to lower the contact drum.
4. Move position indicator on dial indicator to indicate set position for easy repositioning back the desired position later.
5. Remove adjustment handle or wrench.
6. Close access doors.

In the case the contact drum is not properly leveled, a leveling adjustment will be necessary. Before making any leveling adjustments, contact Stiles Machinery for assistance. Leveling adjustments cannot be made before checking head parallelism (from head to head) and conveyor parallelism (from head to conveyor).

CAUTION

Changing the leveling adjustments of heads can affect the performance of the machine and influence the sanding quality. Improper adjustment and leveling can cause damage to machine.

To Make Leveling Adjustment of Contact Drum:

1. Open upper left access doors.
2. Remove abrasive belts (if present).
3. Loosen the two set screws on the coupler located on the contact roller adjustment shaft.
4. Fix the worm gear using a wrench.
5. Turn contact roller adjustment lever. By turning the adjustment lever while fixing the adjustment shaft, only one side of the contact roller will move, allowing the roller to be moved to parallel.
6. Remove fixing wrench.
7. Tighten the two set screws on the coupler located on the contact drum adjustment shaft.
8. Check parallelism between all contact drums and conveyor to ensure proper alignment.

6.7 Adjusting Pressure / Hold Down Roller Position

WARNING

Improper adjustment of hold down rollers could result in workpiece kickback and result in severe injury.

Pressure roller heights are set at the factory. It is very important that pressure rollers are properly set to avoid snipe or thinning at the front or rear edge.

Pressure rollers are set in relation to the sanding heads, which are also set at the factory. Contact Stiles Machinery technical support for detailed tuning information.

As the rubber hold down rollers wear, adjustment may be necessary.

To adjust hold down rollers, loosen locking screw and adjust roller up or down. Roller should be adjusted equally on the left and right side of the machine to ensure consistent hold down pressure and optimal sanding results.

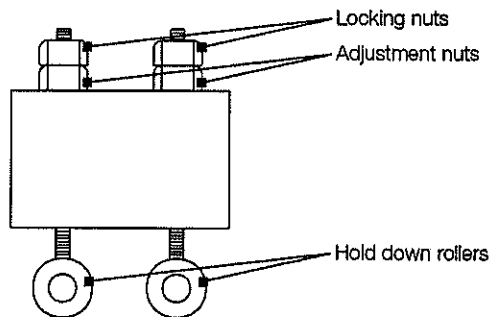

6.8 Adjusting Conveyor Feed Bed

The feed conveyor is supported by 4 jack screws. The Feed conveyor and table are leveled and are set parallel to the contact drums at the factory. In the event that the feed conveyor table requires leveling please follow the instructions below, however, not before consulting with Stiles Machinery's technical support department.

To Level Feed Conveyor Bed:

1. Carefully check the position of the conveyor table at both sides, left to right, and also front to back. Take careful note of which jack screw needs adjustment.
2. Remove clamp from top of dust bellow that covers jack screw to access adjustment point.
3. Loosen locking screw that holds jack screw securely in place to the mounting point.
4. Use wrench to manually turn the jack screw that needs adjustment until plane is level.
5. Tighten locking screw that holds jack screw securely in place to the pointing point.
6. Replace dust bellow and tighten clamp.

6.9 Adjusting Sanding Platen Position

The Ironwood sander has a combination head with a height adjustable sanding pad/platen. The sander has a removable platen with a graphite strip and a felt pad. The graphite strip reduces friction on the back side of the abrasive belt, and the felt pad allows for down pressure without heavy stock removal. The Position and adjustment of the sanding platen depends upon the application.

The sanding load on the sanding platen is adjusted by moving the platen up or down. In general, the sanding platen is suited for final finish sanding and is not intended for heavy stock removal. Normally, the platen is used for finishing grits (normally 150 grit or finer). The primary purpose of the platen is to clean up scratches left from previous sanding grits and prepare the surface for finish. The height of the combination head can be run in three configurations by adjusting the platen height.

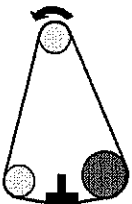

Platen down:
Sanding with pad only
(roller lifted up)

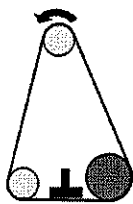

Platen up:
Sanding with roller only

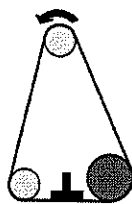

Platen down,
roller down:
Combination Sanding

If sanding platen is down below the contact roller and the contact roller higher than the workpiece, only the platen will be used. If too much down pressure is applied with the sanding platen, the edges of the workpiece will round over due to down pressure of felt sanding pad on the workpiece. Excessive down pressure can damage sanding belt or sanding platen or both.

If the sanding platen is up, contact roller will sand the workpiece and the platen will not contact the workpiece.

If the sanding platen is slightly below the contact roller, combination sanding can be achieved, by which both the contact roller and the sanding platen are in contact with the workpiece in one pass.

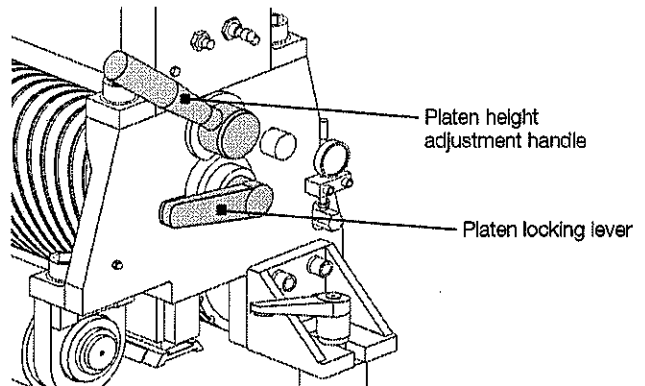

To Adjust Platen Height:

1. Open upper left access doors.
2. Release platen locking lever.
3. Move platen height adjustment handle to move platen up or down. Moving clockwise will raise platen, moving counter-clockwise will lower platen.
4. Lock platen locking lever.
5. Close access doors.

NOTE: Over time, graphite strip and felt pad will wear, requiring adjustment of platen height to maintain sanding result.

Over time, the graphite strip and felt pad will wear and will need to be replaced. To change the felt pad or to replace when the felt pad graphite strip are worn, see section 6.10.

If Sanding Platen is not level, adjustment to the platen should be made. Before making any leveling adjustments, contact Stiles Machinery for assistance. Leveling adjustments cannot be made before checking head parallelism (from head to head) and conveyor parallelism (from head to conveyor).

CAUTION

Changing the leveling adjustments of heads can affect the performance of the machine and influence the sanding quality. Improper adjustment and leveling can cause damage to machine.

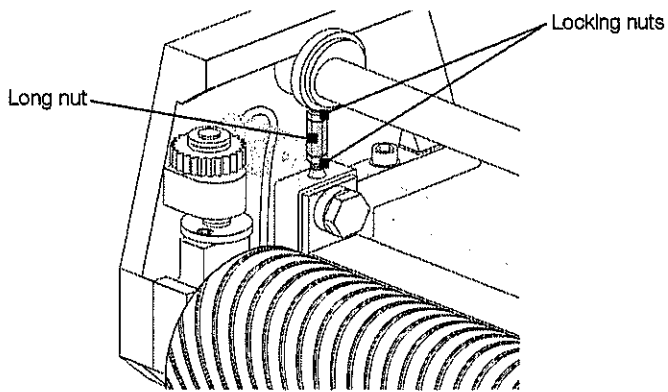

To Make Leveling Adjustment to Sanding Platen:

1. Open upper left access doors.
2. Remove abrasive belts (if present).
3. Loosen the lock nuts on the top and bottom of the long nut.
4. Turn the long nut to move the platen up or down.
5. Tighten the lock nuts on the top and bottom of the long nut.
6. Check parallelism between all contact drums and conveyor to ensure proper alignment.
7. Close access doors.

6.10 Platen Maintenance and Replacement

The platen must be kept clean. Clean graphite on platen daily and inspect platen for wear. After sanding, if the graphite strip and felt pad have visible lines or show wear (gouges, lines, raised or flat spots, the graphite strip and felt pad should be replaced. Failure to replace worn platen materials will cause telegraphing through the belts and onto the work pieces.

A platen maintenance schedule should be defined based upon machine usage to ensure optimal sanding results.

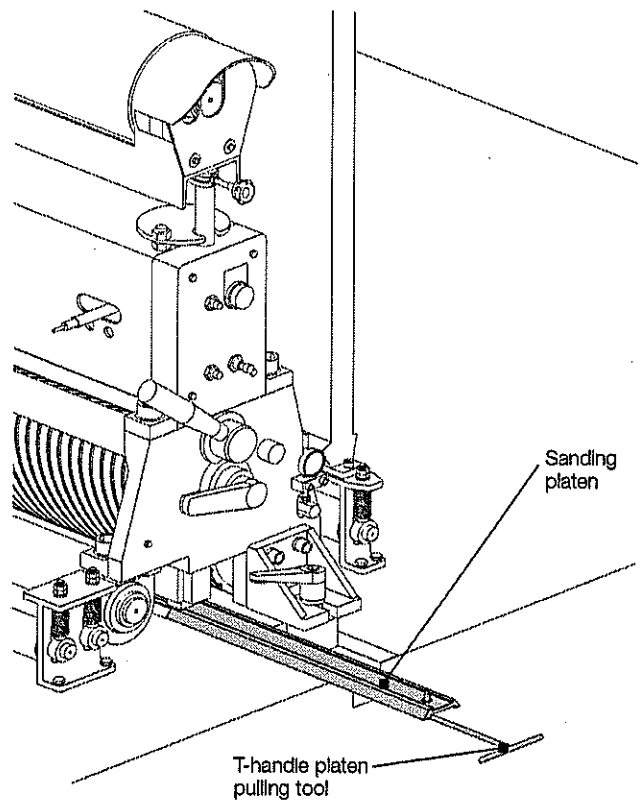

To Inspect or Replace Platen:

1. Open upper left access doors.
2. Remove Abrasive belt.
3. Locate T-handle platen pulling tool.
4. Hook platen pulling tool onto platen.
5. Pull platen out of machine for inspection.

NOTE: platen fits snugly in machine and requires some force to remove.

6. Inspect platen for wear.
7. Replace platen materials if necessary.
8. Slide platen back in machine.
9. Remove T-handle platen pulling tool and close access doors.

Parts necessary for changing platen materials can be obtained from Stiles Machinery's parts department by calling 1-800 PARTS 80 (1-800-727-8780).

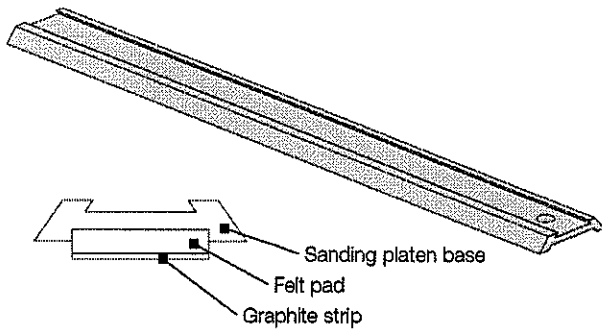

To Change Sanding Platen Materials:

1. Scrape old felt and graphite off of sanding platen base.
2. Clean sanding platen base extremely well. No glue residue can be left behind.
3. Put double side adhesive sticky film in groove on sanding platen base.*
4. Lay felt in groove and roll with a heavy metal roller to ensure proper adhesion.
5. Put double side adhesive sticky film on back side of graphite (if no adhesive is already pre-applied).
6. Stick graphite onto top side of felt pad and roll very well with heavy metal roller. Ensure front edge of graphite does not have a long overhang or it can fold over during sanding and adversely affect sanding result.

*Adhesive sticky film that should be used is a very important. Please contact Stiles Machinery to obtain the correct adhesive. If incorrect double side sticky film is used, delamination can occur due to heat during the sanding process.

NOTE: When purchasing graphite and felt from Stiles, graphite and felt will already be attached together. Peel tape off backside of felt and secure onto sanding platen base.

6.11 Machine Thickness Adjustment

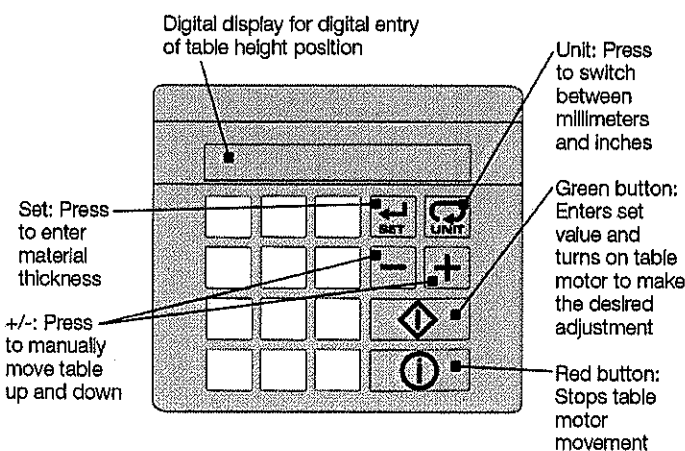

To set material thickness, use the keypad entry. The digital display displays increments of 0.001". Manual table elevation buttons on control panel can also be used for manual height adjustment.

The worktable is mounted on the machine frame. The desired depth of cut is achieved by adjusting the table height. The table raises and lowers on four jack screws mounted on thrust bearings.

This sander is equipped with easy-to-read digital thickness display.

To set the machine thickness, adjust using the keypad entry on the front of the machine, as follows:

NOTE: Press the unit key to select inches or millimeters prior to height adjustment.

1. Press Set.
2. Enter the desired machine thickness.
3. Press the green On button. The table will raise or lower to the desired height.
4. To fine-tune material thickness, turn the micro-adjustment control knob located on the front of the machine below the feed conveyor.

To size a workpiece, measure the workpiece thickness using a caliper or any other measuring instrument. If the workpiece is 19.4mm and the desired thickness is 19.0mm, set the machine thickness to 19.0mm. It is important to remember that the amount of stock removal depends upon the material type, the sanding belt grit and the conveyor speed. Depending on the workpiece thickness and the desired final workpiece thickness will determine how many passes will be required.

Change table height

To move the table up or down, repeat Step 6.10 or press the Up or Down button on the control panel to jog the thickness of the machine up or down.

Table Height Presets:

There are 99 preset values that can be entered into the controller. Presets are numbered 0-9 and can be used to save the most commonly used positions.

To set a preset value:

1. Press the number on the keypad to use as a preset.
2. Press the C key to clear the previous setting value. The display should change to 0.0 and flash.
3. Enter the preset value.
4. Press and hold the SET button for 3 seconds.

To use a preset value:

1. Select the desired preset number by typing the number into the keypad.
2. Press the green On button to move the table to the preset value.

Table height limits

A limit switch defines how far the table will raise or lower. When a limit switch stop on the table comes in contact with a limit switch, the table motor switches off to prevent damage in maximum high and low positions

Minimum height for machine is 3mm (1/8")

Maximum height for machine is 125mm (4.9")

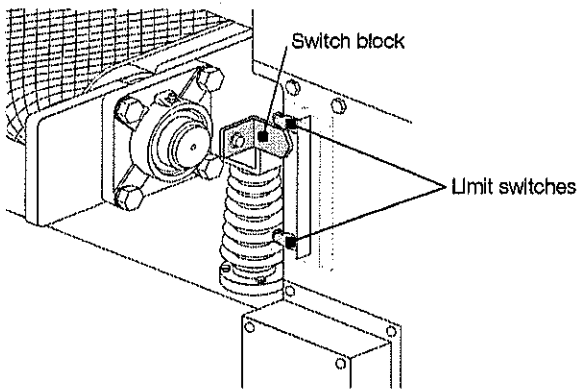

Limit switches turn off the table motor when contacted by the switch block.

Calibrate

If the machine feed conveyor height is not accurate, a calibration procedure should be performed. This will also need to be performed after dressing the conveyor belt to properly set the height.

To Calibrate:

1. Press SET
2. Enter the actual feed conveyor height
 - a. This can be done by sanding a workpiece and then measuring the actual thickness of the workpiece. Once the exact thickness is obtained, enter that value into the control.
3. Press and hold the SET button until the "." on the display stops blinking. When the blinking stops, the height is calibrated.

6.12 Adjusting Conveyor Belt Tension and Tracking

Ironwood sanders come standard with automatic conveyor belt tracking. Belt tension must be set properly and belt must be properly aligned for automatic conveyor belt tracking to perform properly. Automatic oscillation of conveyor belt is controlled by a micro switch and oscillation air cylinder. For auto conveyor belt tracking to function properly, the conveyor belt must be equally tensioned.

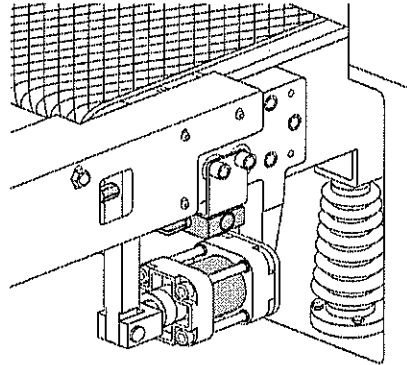

To Adjust Conveyor Belt Tension:

1. Turn conveyor belt on.
2. Adjust the tensioning screws located on the front of the feed conveyor. Tensioning screws can be accessed from the left and right side of the conveyor belt. Access holes are located to properly access the tensioning screws.
3. Once tension is correct, adjust the screws so the conveyor tracks to the center of the conveyor bed.

NOTE: Over tensioning the conveyor belt may affect the life of the conveyor belt.

6.13 Dressing Conveyor Belt

When conveyor belt starts to dry out and parts seem to be slipping on the conveyor belt surface. It may be time to dress the conveyor belt.

To dress the conveyor belt:

1. Load a 60 grit sanding belt on the first head.
2. Ensure the subsequent heads are raised so only the first head contacts the feed conveyor.
3. Turn on feed conveyor and change conveyor speed to slowest speed.
4. Jog machine to minimum thickness (3mm) until it hits the minimum thickness limit switch.
5. Start sanding head 1.
6. Manually turn conveyor bed up with the fine adjustment hand wheel until the feed track is just touching the sandpaper, so that the sandpaper exposes fresh rubber on the surface of the feed conveyor.
7. Manually turn conveyor bed down with the fine adjustment hand wheel to open the machine back up.

7.0 Machine Operation

Before operating the sander, make sure that:

- Dust collection system is turned on.
- Abrasive belt is tensioned.
- Abrasive belts are turning in the correct direction.
- Abrasive belt tracking and oscillation is working correctly and abrasive belts are tracking consistently.
- All adjustment screws and handles are securely tightened.
- Conveyor belt is tracking properly.
- Working air pressure is sufficient and properly set at 90 PSI (6 bar).
- Working thickness is properly set on the controller.
- Feed rate is properly set.
- Workpiece is free of nails, staples, knots or other obstructions.

WARNING

Do not operate this machine with the safety guard removed.

WARNING

Before starting the machine, inspect it to ensure machine is free of all debris.

WARNING

Never start the machine with the workpiece in contact with the cutterhead.

NOTE: When setting up the machine for initial operation, see section 7.3 for proper machine setup.

Step 1: Turn on power to machine and power to dust collector

Turn the main power to the machine on the electrical cabinet on by turning the main power switch to the on position.

Turn control power on the controller on by turning control power knob to the on position.

Turn power to dust collector on.

Step 2: Load proper abrasive belts onto machine and set sanding heads

Identify proper grit sequence required for material being sanded.

Load proper abrasive belts onto machine and tension abrasive belts.

Set contact roller height and sanding pad height for each head depending upon grit sequence and desired sanding results. See section 6.6 and 6.7 for proper adjustment of contact rollers and sanding pad.

Choosing proper abrasive belts for optimal sanding results is critical. See section 7.2 for help with selecting proper abrasive belts.

Step 3: Measure workpiece thickness and enter desired machine thickness into controller

Measure workpiece thickness with caliper.

Enter desired workpiece thickness into machine controller. See section 6.9 for detailed instructions for setting conveyor thickness.

CAUTION

Stock removal depends upon multiple factors including material being sanded, abrasive belt grit and conveyor speed. There are limits to the stock removal. If too much material removal is attempted, machine damage may occur.

Step 4: Turn feed conveyor On and set feed speed

Press the green Feed Conveyor On button to turn feed conveyor on.

Turn feed speed adjustment knob on back side of machine to adjust feed speed only when feed conveyor is on. Feed speed range is 4 – 16 MPM (15-52 FPM).

Step 5: Turn Sanding heads On

Press the green Sanding Head On button. When turning the sanding head on, watch the amp meter. When the amperage drops and shows a small uptick, the sander is ready to run.

Step 6: Feed workpiece into machine

WARNING

Make sure the workpiece is free of nails, staples, loose knots, and other defects that could cause personal injury or damage the machine.

Keep fingers and hands away from the cutting area. Keep hands away from the top surface of the board near the finger/over thickness protection.

If it is necessary to stop a workpiece before it is entirely fed through the machine, press In Feed Off. The sanding head must also be turned off. WAIT until the sanding head has completely stopped before lowering the table to remove material. Attempted removal while head is turning may cause kickback.

Set workpiece on the feed conveyor and feed workpiece into machine with grain.

The maximum stock removal in a single pass depends upon multiple factors and it may be necessary to pass the workpiece several times to achieve the desired finished workpiece thickness and finished sanding quality.

Step 7: Stop the Machine

1. Press In Feed Off button.
2. Press sanding head Off buttons.
3. Turn Power knob to Off.
4. Make sure the work area is clean.

7.1 Noise Reduction

- Always use hearing protection.
- Make sure tooling (abrasive sanding belts) are in proper working condition.
- Properly position material and guards.
- Use proper tooling and feed speeds for application.

7.2 Abrasive Belt Selection and Application

⚠ WARNING

Abrasive sanding belts can be very sharp. Be careful when working with tooling as serious injury may occur.

Refer to section 6.4 for proper abrasive belt loading, tensioning and tracking.

To ensure safe and efficient cutting, the tooling should be suitable for the material being cut. The tools should be sharp and properly set.

Use extra precautions when handling abrasive sanding belts.

Sanding belt selection depends entirely on the desired outcome. Typically, to properly prepare a wood surface for finishing, sanding grits must be used in a sequence to remove the deeper scratch caused by the lower sanding grits. If grits are skipped, it may be difficult to remove deep scratches caused by lower sanding grits.

Lower sanding grits have a greater stock removal capacity but create a deeper scratch. Higher sanding grits have a lesser stock removal capacity and create a more shallow scratch. The goal with a grit sequence is to remove enough material so that the deep scratches created initially with the primary grit are completely removed with the final grit.

Stock removal is determined more by the abrasive belt than by the machine. Each abrasive belt is designed to remove a certain amount of stock, and if that amount is exceeded, the life of the belt is adversely affected. As a rule, using a contact roller on wood work-piece at a slow speed (approx. 15 ft./min.), the following stock removal could be expected:

Stock Removal Level	Grit	Stock Removal (inches)	Stock Removal (mm)
Heavy	36	1/8"	3mm
Moderate	80	1/32"	0.8mm
Moderate	100	1/32"	0.8mm
Light	120	1/64"	0.4mm

Belts in grits from 150 on up should only be used for finishing and are not considered cutting belts. Other factors affecting stock removal other than grit are:

- Abrasive belt speed
- Type of sanding head
- Type of contact roller
- Conveyor Feed speed
- Available horsepower

First you must decide what grit you want to finish with and then work backwards taking into account how much total material you are looking to remove. When using contact rollers or drums, you should not skip more than one grit in any sequence to optimize abrasive life and ensure the highest quality finish.

Typical Grit Sequence for calibrating and sanding 5-piece kitchen cabinet doors:

- 1) Contact Roller @ 100 grit
- 2) Contact Roller @ 150 grit
- 3) Platen @ 180 grit (can also combination sand with roller and pad)

Generally speaking, a contact roller is used for stock removal and a platen is used for finish sanding; however, rollers are also used for finish sanding in some applications. A rule of thumb would be that, if you need to remove more than 0.003 to 0.004 inch (0.1mm), you should use a contact roller, otherwise a platen may be used.

As a rule of thumb, when sanding with a contact drum, it is possible to skip a grit. For example, it is ok to go from 100 to 150 grit, skipping the 120. On the other hand, it is not ok to skip a grit between a contact drum and a platen. The next sequential grit should always be used when sanding from a drum to a platen. The reason for this rule is because the deeper scratches from the first head cannot be removed by a finer grit because the stock removal capacity of a finer grit is much lower than a heavier grit. For example, if I sanded with a 100 grit, 180 and 220 grit, although my surface may feel smooth, the deep scratches from the 100 grit are still present and will normally not show up until after staining and finishing. To visualize this see image below.

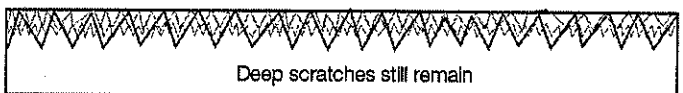

■ 100 grit scratch ■ 180 grit scratch ■ 220 grit scratch

In contrast, when a grit sequence is used where no more than one grit is skipped from drum to drum and no grits are skipped between drum and platen, the initial deep scratches can be removed and the finish quality will be better.

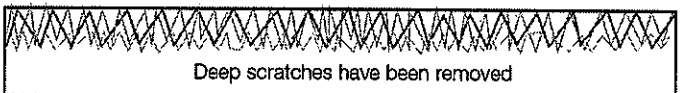

■ 100 grit scratch ■ 150 grit scratch ■ 180 grit scratch

The difference between the finish produced by a contact roller versus a drum is also seen in the finish. A drum will produce a short scratch pattern, but it is deeper on a given grit. A platen will produce a longer scratch that is not as deep. You really need to determine stock removal requirements and desired finish to decide which will fit your individual needs.

The sanding platen should only be used with grits 150 and above. The platen is intended for finish sanding, not heavy stock removal.

Abrasive Belt Tips:

- Hang belts for at least 24 hours prior to use to remove any shape caused by packing.
- Store abrasive belts in dry area.
- Avoid direct contact between the floor and abrasive belt.
- Store abrasive belts between 64 and 72 degrees F.
- Avoid direct sunlight exposure on abrasive belts.

7.3 Setting Up Machine

When setting up machine for the first time, or simply adjusting machine based on the specific job or sanding grits, several steps should be taken to ensure machine is properly setup to optimal sanding results.

Follow the procedure below to properly setup machine:

1. Obtain a workpiece 2 – 4" wide and long enough to fit under all sanding heads with extra material on infeed and outfeed of machine. Workpiece should be wood with a thickness of approximately 1" (25mm).
2. Measure exact part thickness with a digital caliper.
3. Set controller to exact part thickness.
4. Use a lead pencil to mark the top surface of the part to be sanded. Mark the part with squiggly lines the entire length of the workpiece.

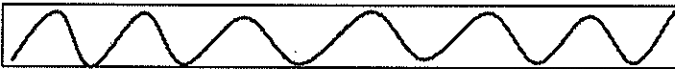

5. Load the machine with 100 grit.
6. Turn all heads of the machine on and sand the part.
7. Check the part to see if the pencil mark was removed from all areas of the part. If not, lower machine by 0.5mm and sand part again.
8. Check part thickness and make sure part thickness matches controller thickness. If not, calibrate thickness.

8.0 Maintenance

⚠ WARNING

Before performing any type of maintenance or adjustments, make certain that the machine is disconnected from its power source and turned completely off.

⚠ WARNING

Never operate the machine until it has been properly lubricated and all necessary maintenance work has been completed.

NOTE: after changing a setting, making an adjustment, performing repair/maintenance work, or troubleshooting, please check that all applicable safety functions are working properly before performing another operation.

Thoroughly clean machine, inside and out, and surrounding areas every day.

Keep a maintenance record and perform recommended maintenance checks.

8.1 Lubrication

Lubricate the items listed below according to the following interval.

Location	Interval	Product
Grease bearings (all heads and rollers)	150 hrs	Grease
Table lift screws (4)	Monthly	Grease or
Table slide ways (2)	Monthly	SAE-30 light oil
FRL Filter Regulator Unit	Quarterly	SAE-30 light oil

Do not get oil on the pulleys and belts. If they are dirty, use paper towel or a soft rag to clean and dry them.

Location	Bearing Qty
Contact Roller (contact drum or combi head)	2 ea.
Tensioning roller – upper	2 ea.
Idler roller – lower (combi head)	2 ea.
Feed rollers – front and rear	2 ea.
Hold down pressure rollers	2 ea.
Elevation drive	2 ea.
Elevation idle wheel	1 ea.

8.2 Inspection

Feature	Interval/Situation
Abrasive Belts	Hourly – check for loading and belt wear and change when belts are loaded or show wear signs to ensure desirable sanding quality
Sanding Heads	Daily
Sanding Pad	Daily – clean and check for wear
Abrasive belt tracking photo eye	Daily – clean off dust to ensure eye remains clean
Drive Belts	Weekly for first 3 weeks, every 1,000 hours of use or check belt whenever it becomes frayed after that
Emergency stop	Daily – by functional test
Door safety switches	Daily – by functional test
Pneumatic disc brakes	Daily – by functional test
Electrical cabinet/system	Monthly - check wiring, loose terminals, insulation deterioration.

NOTE: After changing a setting, making an adjustment, performing repair/maintenance work, or troubleshooting, please check that all applicable safety functions are working properly before performing another operation.

8.3 Periodic Maintenance

It is important to periodically clean the inside of the machine well.

Periodic machine cleaning increases the life of the machine and its performance.

Sanding pad will need servicing periodically based upon usage. New felt and graphite should be used when existing felt and graphite pad wear. Once graphite is smooth and shiny, or if wear marks can be seen in pad or sanding results are uneven, graphite and felt should be replaced.

Empty the water accumulated in the filter cup on the F.R.L air filter regulator lubricator quarterly or when full.

Replace oil in the gear reducer after the initial 300 working hours. After initial oil change, replace oil every 2500 working hours. Use 140# gear oil in gear reducer, or reference specific oil types located on oil change sticker located on rear of machine.

To replace ball bearings, please contact Stiles Machinery's Parts Dept at 1-800-727-8780.

9.0 Troubleshooting

Trouble	Possible Cause	Solution
Machine will not start.	<ul style="list-style-type: none"> No incoming power. Low or high voltage. Loose wiring. Fuse is blown or circuit breaker is tripped. Sanding belt not properly tensioned. Belt breakage switch is tripped. Door is open or door switch is not making proper contact. Air pressure is too low. Sanding belt tripped over travel switch. Overload protection tripped. Overthickness switch is tripped. Switch is defective. Replace motor. Emergency stop is pushed. 	<ul style="list-style-type: none"> Check that the sander is connected to power, there is power on all three phases and a fuse is not blown. Check voltage at power source. Inspect and correct any loose connections on machine. Replace fuse or reset circuit breaker. Tension sanding belt with switch. Check belt breakage switch and properly position. Close door or check for door switch contact. Check pressure on pressure gauge and adjust on FRL regulator unit if necessary. Reposition belt and adjust belt tracking. Reset overloads. Remove material touching overthickness device. Replace switch. Replace motor. Check emergency stop switches and reset.
Machine Stops frequently.	<ul style="list-style-type: none"> Feeding material too quickly or removing too much material. Overload tripped. Water in air circuit. Air circuit obstruction. Sanding belt issue / belt breakage sensor gap needs resetting. 	<ul style="list-style-type: none"> Slow feed rate and or remove less material. Check sandpaper for loading and or reduce sanding load. Drain water from FRL regulator unit. Check if any debris is clogging FRL regulator unit. Check sandpaper and belt breakage sensor position.
Conveyor belt is slipping or running off to one side or the other.	<ul style="list-style-type: none"> Conveyor belt tension too loose. Belt is not tensioned evenly. 	<ul style="list-style-type: none"> Adjust tensioning screws on front of conveyor to properly tension conveyor belt. Adjust tension so left and right side of belt is evenly tensioned.
Sanding head will not run or abrasive belt is slipping.	<ul style="list-style-type: none"> Check incoming air pressure is too low. Emergency stop is engaged or door is open. Limit switches are activated. Abrasive belt is slipping. Abrasive belt tensioning cylinder is failing. 	<ul style="list-style-type: none"> Ensure air pressure is above 4 bars. Check doors and emergency stop switches. Position sanding belt so it is between limit switches. Ensure belt breakage switch is in correct position below the top limit set point. Check air pressure and increase pressure if below 5 bar. Replace or rebuild belt-tensioning cylinder.
Abrasive belt will not stay running (keeps tripping limit switches).	<ul style="list-style-type: none"> Sanding belt is not uniform in size. Abrasive belt oscillation is not properly adjusted. Belt oscillation air flow control is closed. Photo eye is not working properly. 	<ul style="list-style-type: none"> Check sanding belt circumference. If belt is more than ¼" different in size from one side to the other, replace. Set belt oscillation by adjusting oscillation controls and adjusting belt tracing. Open air flow valve and adjust for proper tracking. Test photo eye by placing hand in front of photo eye to see if that actuates the air cylinder. If you hear the air valve open but nothing happens, the oscillation cylinder needs replacing. If not, photo eye needs adjustment or replacing or air solenoid valve needs replacing.
Photo eye for belt oscillation is not working properly.	<ul style="list-style-type: none"> Photo eye is not seeing sandpaper. Solenoid valve is not working. 	<ul style="list-style-type: none"> Photo eye needs replacing or adjustment. Photo eye needs cleaning, clean eye with a clean, dry rag. Replace solenoid valve.

Trouble	Possible Cause	Solution
Belt is running to one side or inconsistent oscillation speed.	Sanding belt is not uniform in size. Check bearings on idler roller. Upper tensioning assembly loose.	Check sanding belt circumference. If belt is more than ¼" different in size from one size to the other, replace. If bearings or bearing is worn and has "play", replace bearings. Check screws connecting tensioning cylinder to upper roller assembly. Tighten if necessary.
Machine is not stopping quickly after emergency stop is pressed.	Air pressure is too low. Brake pads are worn. Rotors are worn.	Increase air pressure to 5 bars or more. Replace brake pads. Replace rotors.
Loud noise when pneumatic brakes are activated.	Brake pads are worn.	Replace brake pads and check rotors for wear.
Workpiece is thinning at front edge.	Insufficient pressure on front hold down rollers.	Adjust hold down pressure of front hold down rollers.
Workpiece is thinning at back edge.	Insufficient pressure on rear hold down rollers.	Adjust hold down pressure of rear hold down rollers.
Un-even thickness between front and rear end of workpiece.	Uneven pressure between hold down rollers and contact drum.	Check height of hold down rollers and adjust as necessary.
Sanding belt overloading or machine jamming.	Sanding load is too high. Sandpaper grit is too fine. Insufficient dust extraction. Heavy glue on workpiece. Workpiece moisture is too high.	Remove less material in a single pass and or slow feed conveyor. Change sandpaper grit. Check dust collector and ensure proper suction. Check sanding belt for loading and adjust stock removal and feed speeds. Kiln dry wood before sanding to prevent quick loading of abrasive belts causing overloads.
Round over on workpiece edges.	Too much pressure on hold down rollers. Too much down pressure on sanding pad. Too much down pressure on rubber contact roller.	Adjust hold down pressure. Adjust sanding pad height. Remove less material.
Uneven thickness between left and right side of the workpiece (Tolerance over +/- 0.1mm)	Contact drum is not level. Conveyor table is not properly leveled. Contact drum surface is damaged. Un-even sanding belt wear. Too much load on sanding pad and uneven wear on sanding pad. Dust or debris under the conveyor belt or on the conveyor belt or table.	Re-level contact drum. Check the 4 elevation screws located under the conveyor table. Loosen the lock screws and turn the screws by using a wrench. Turn clockwise to raise the table or counter-clockwise to lower the table. Adjust front and rear screws together so they are level front to back. Check contact drum surface. If badly damaged, contact drum will need repair. Replace sanding belt. Reduce down pressure on sanding pad and or replace felt and graphite insert. Clean conveyor belt and conveyor table.
Workpiece slips on conveyor belt.	Hold down rollers are too low. Conveyor belt is too smooth / slippery / worn. Too much dust on conveyor belt and or conveyor has buildup on it.	Adjust hold down roller height. Dress conveyor belt or replace if belt has become too thin. Clean conveyor belt and or dress belt.
Straight notches on workpiece surface.	Dust or debris on pressure / hold down roller. Hold down rollers are not turning smoothly. Object stuck in contact drum, in sanding pad or under sandpaper. Worn or loaded sandpaper.	Clean pressure / hold down rollers. Hold down roller bearings need replacing. Check contact drum surfaces, clean contact drums, check sanding pad and check sandpaper. Replace sandpaper.

Trouble	Possible Cause	Solution
Wavy marks on workpiece surface.	Worn or loaded sandpaper.	Replace sandpaper.
	Belt oscillation is too fast.	Slow belt oscillation speed.
Horizontal marks on workpiece surface.	Sanding belt joint is poor.	Replace sandpaper.
	Bearing damage.	Replace bearings on contact drum.
Sheen on workpiece surface.	Worn or loaded sandpaper.	Replace sandpaper.
	Sandpaper grit is too fine.	Change sandpaper.
	Contact drum is too high.	Lower contact drum or remove more material.
	Feed speed is too slow.	Adjust feed speed.
Feed speed will not change.	Mechanical clutch is broken.	Replace clutch.

If you cannot resolve your issue, contact efiles technical support at 616.698.6815.

9.1 Electrical Diagram

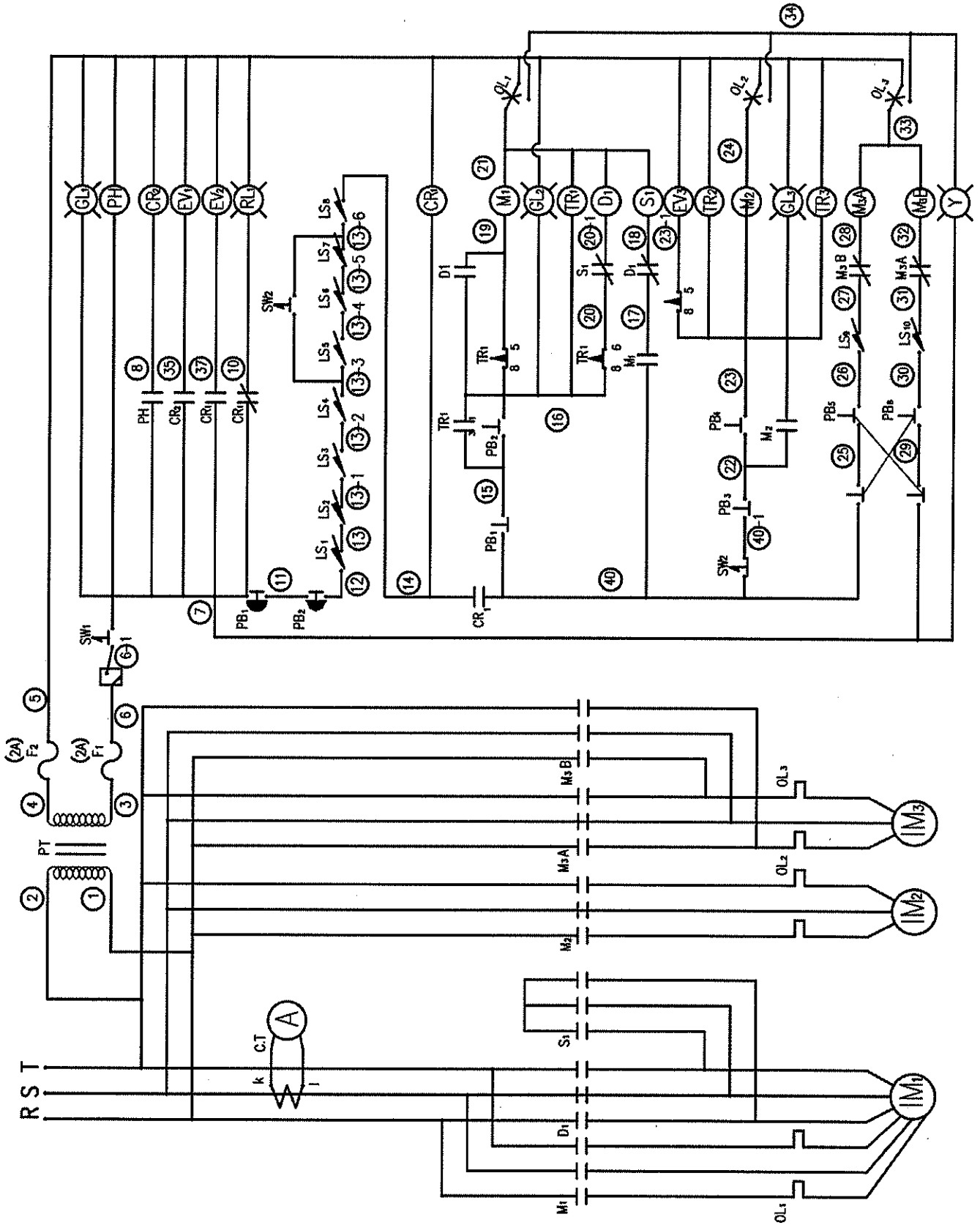

9.2 Pneumatic Diagram

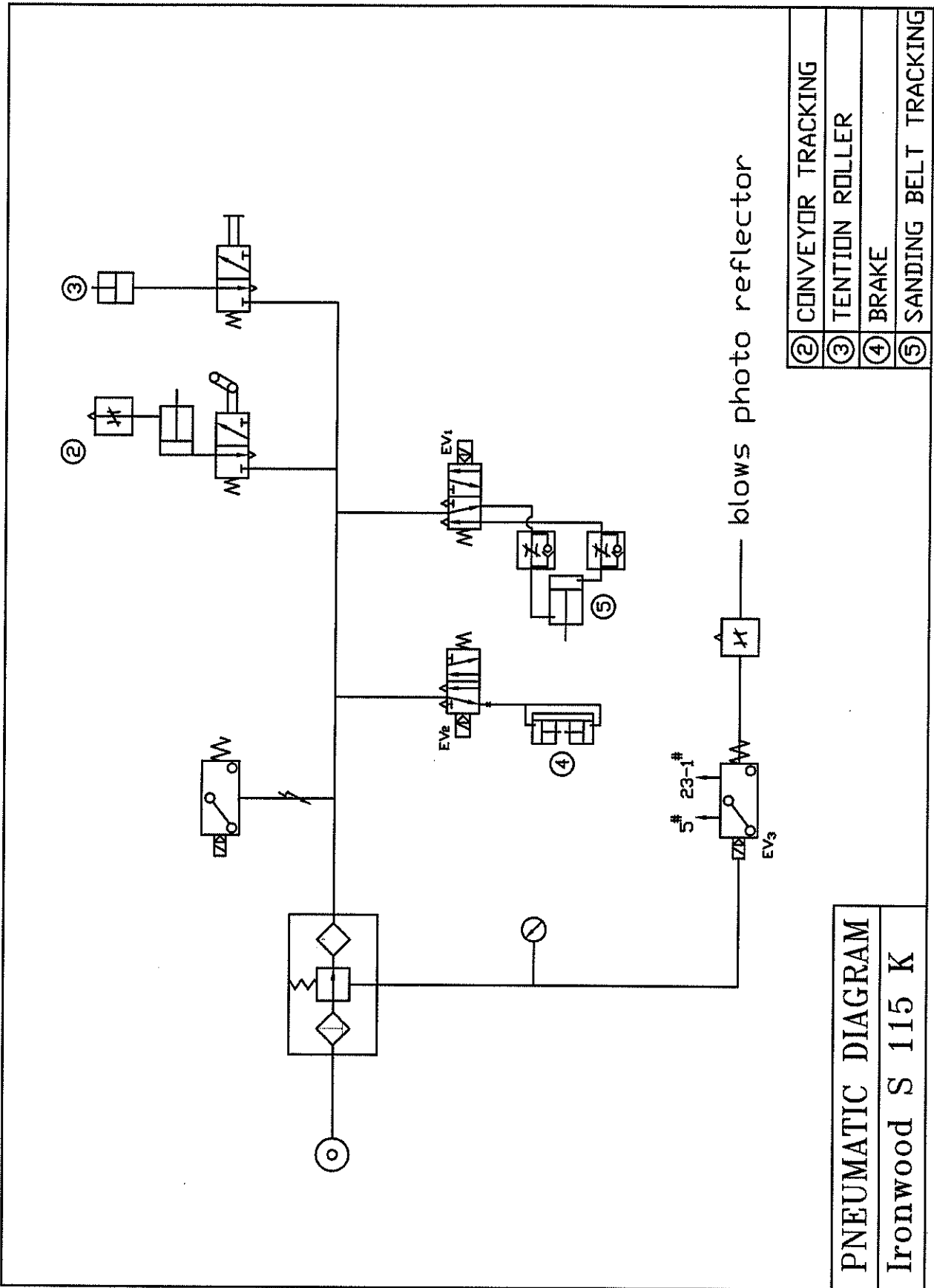

②	CONVEYOR TRACKING
③	TENSION ROLLER
④	BRAKE
⑤	SANDING BELT TRACKING

PNEUMATIC DIAGRAM
Ironwood S 115 K

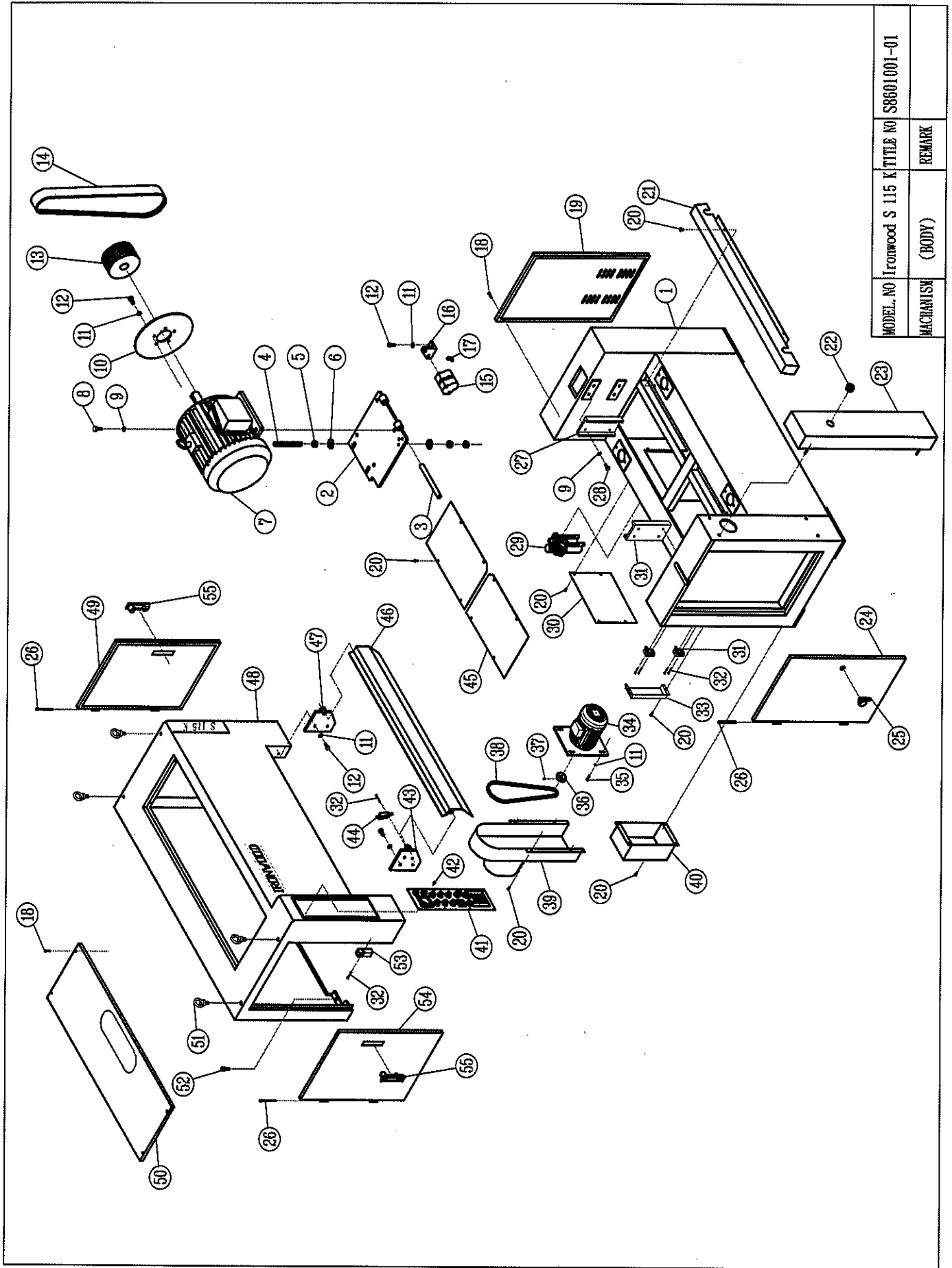

MODEL NO Ironwood S 115 K TITLE NO S8601001-01	REMARK
MACHINIS (BODY)	

PRODUCT		WIDE BELT SANDERS	<u>PARTS LIST</u>		FILE NO.	S8601001-01
MODEL		Ironwood S 115 K			TOTAL PAGE	11
MECHANISM		BODY			REMARK	
NO.	PART NUMBER	PART PRODUCT	SPECIFICATION	Q. T. Y		
1	S8601001	MACHINE FRAME		1		
2	2601003	MOTOR PLATE	20HP	1		
3	1001037	HINGE ROD		1		
4	M5402071	ADJUSTED STUD	M14x140	2		
5	MS501400	NUT	M14	4		
6	MS600114	LOCK WASHER	M14	4		
7	MT2514620	MOTOR	25HP,4P,CW	1		
8	MS101030	HEX HEAD BOLT	M10x30	4		
9	MS600110	LOCK WASHER	M10	8		
10	3001031	BRAKE DISC	Ø12"	1		
11	MS610105	LOCK WASHER	M8	13		
12	MS100820	HEX HEAD BOLT	M8x20	15		
13	S8601021	MOTOR PULLEY		1		
14	MRP1120765	POLV-BELT	12PL-765L	1		
15	3001055	BRAKE BLOCK BRACKET (L)		1		
16	MJ124400	BRAKE BLOCK		1		
17	MQ030112	L-JOINT	1/8"	1		
18	MS000630	PAN HEAD BOLT	M6x30	4		
19	S8601007	MOTOR GUARD PLATE		1		
20	MS000612	PAN HEAD BOLT	M6x12	17		
21	S8601005	SPROKET GUARD		1		
22	MQ113003D	PRESSURE GAUGE	10KG	1		
23	TS8601001-06	FRONT PLATE		1		
24	S8601020	RIGHT LOWER PLATE		1		
25	MO026002	DOOR LOCK	A-172	1		
26	MO030100	HINGE ROD	3/8" x100mm	6		
27	O101015	TABLE SLIDE (EXTERNAL)		2		
28	MS101025	HEX HEAD BOLT		8		
29	MQ120201B	TRIBLE FUCTION SET		1		
30	1001026	MOTOR GUARD PLATE		1		

PRODUCT		WIDE BELT SANDERS		FILE NO.	S8601001-01
MODEL		Ironwood S 115 K		TOTAL PAGE	11
MECHANISM		BODY			
NO.	PART NUMBER	PART PRODUCT	SPECIFICATION	Q. T. Y	
31	MN067311	LIMIT SWITCH	7311	2	
32	MS000630	PAN HEAD BOLT	M6x30	4	
33	S3001078	LIMIT SWITCH GUARD		1	
34	MT0034620	MOTOR	1/2HP,4P	1	
35	MS100830	HEX HEAD BOLT	M8x30	4	
36	0102002	MOTOR PULLEY		1	
37	MS400610	SET SCREW	M6x10	1	
38	MR010040	V-BELT	A40	1	
39	1801046	PULLEY GUARD		1	
40	S7004013	TERMINAL GUARD		1	
41	MSM7601013	SWITCH PLATE		1	
42	MS000410	PAN HEAD BOLT	M4x10	8	
43	43N67	SAFT GUARD BRACKET(L)		1	
44	MN068112	LIMIT SWITCH	8112	1	
45	S8601003	FRAME TOP PLATE		2	
46	S8004011	SAFT GUARD		1	
47	43N67A	SAFT GUARD BRACKET(R)		1	
48	ST8601001	GUARD COVER		1	
49	ST8601001-3	RIGHT UPPER PLATE		1	
50	ST8601001-1	TOP PLATE		1	
51	MS910900	RING HEAD SCREW	M16	4	
52	MS201230	HEX SOCKET CAP BOLT	M12x30	8	
53	MN06EK15	DOOR SWITCH		2	
54	ST8601001-3	LEFT UPPER PLATE		1	
55	M0025000	DOOR LOCK		2	

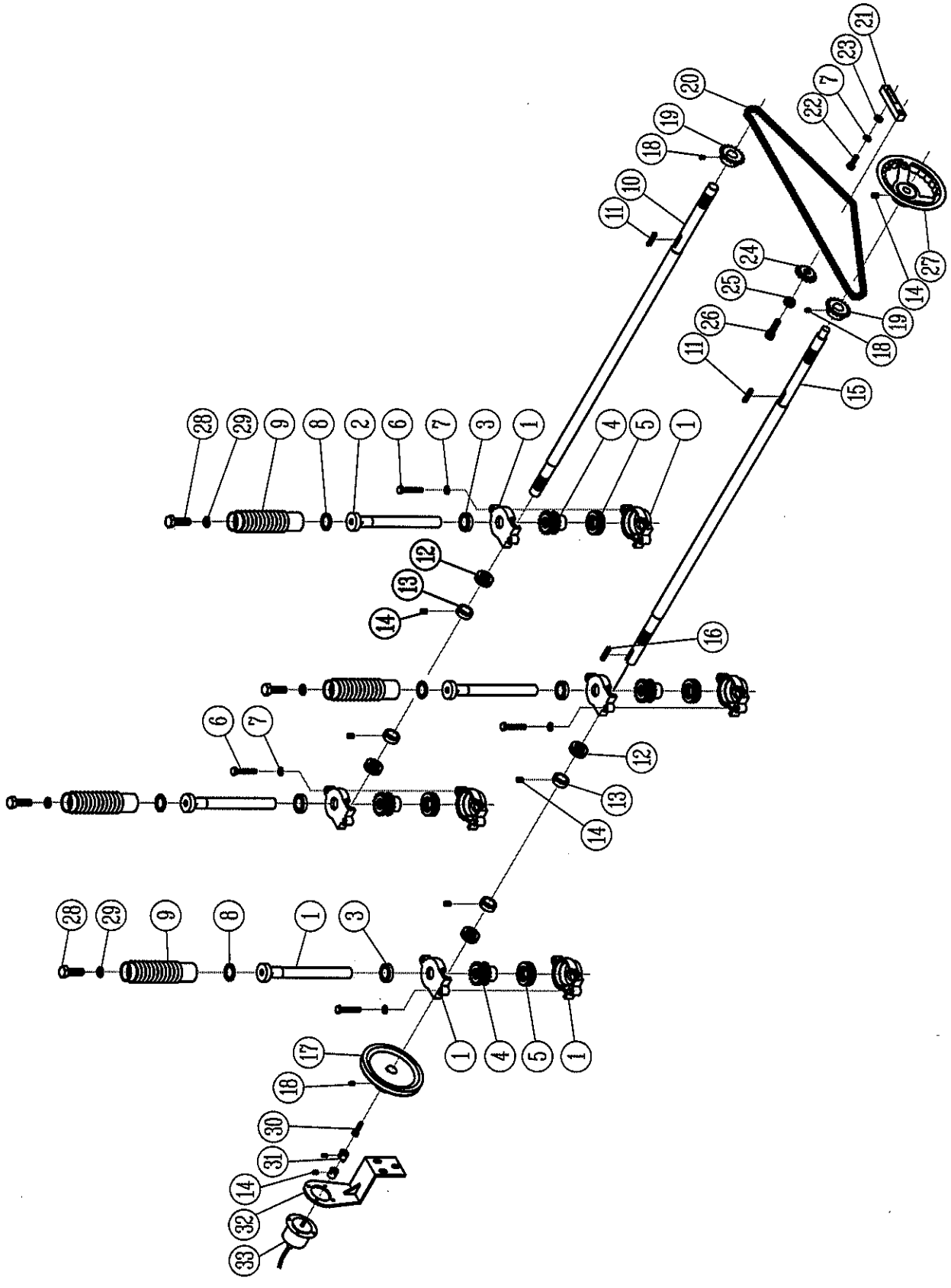

MODEL NO	Ironwood S 115 K	TITLE NO	SS601001-02
MACHANISM	(TABLE HOIST)	REMARK	

PRODUCT		WIDE BELT SANDERS		FILE NO.	S8601001-02
MODEL		Ironwood S 115 K		TOTAL PAGE	11
MECHANISM		TABLE HOIST			
<u>PARTS LIST</u>					
NO.	PART NUMBER	PART PRODUCT	SPECIFICATION	Q. T. Y	
1	0102009	WORM GEAR CASE		4	
2	0102006	HOIST COLUMN		4	
3	0102011	SPINDLE SPACER		4	
4	0102008	WORM GEAR		4	
5	MB002907	BALL THRUST BEARING	2907(T)	4	
6	MS100855	HEX HEAD BOLT	M8x55	8	
7	MS600108	LOCK WASHER	M8	9	
8	M0080001	GEAR WASHER	AW-1"	4	
9	M0041300	SLEEVE		4	
10	S7601017	WORM ROD (R)		1	
11	MK287040	KEY	8x7x40	2	
12	MB051105	BALL THRUST BEARING	51105(T)	4	
13	0102010	SET COLLAR		4	
14	MS400810	SET SCREW	M8x10	6	
15	S7601016	WORM ROD (L)		1	
16	MK287040	KEY	8x7x40	1	
17	0102003	WORM ROD PULLEY		1	
18	MS400610	SET SCREW	M6x10	5	
19	D0101019	SPROKET		2	
20	MB940035	CHAIN	#35x	5尺	
21	3001074	IDLE SPROKET BRACKET		1	
22	MS100830	HEX HEAD BOLT	M8x30	1	
23	M3001002	SPACER		1	
24	M0102012	IDLE SPROKET		1	
25	MB206201	BALL BEARING	6201LLB	1	
26	MS201030	HEX SOCKET CAP BOLT	M10x30	1	
27	M0102013	HAND WHEEL		1	
28	MS101240	HEX HEAD BOLT	M12x40	4	
29	MS600112	LOCK WASHER	M12	4	
30	MS200830	HEX SOCKET CAP BOLT	M8x30	1	

PRODUCT	WIDE BELT SANDERS	<u>PARTS LIST</u>	FILE NO.	S8601001-02
MODEL	Ironwood S 115 K		TOTAL PAGE	11
MECHANISM	TABLE HOIST		REMARK	

NO.	PART NUMBER	PART PRODUCT	SPECIFICATION	Q. T. Y	
31	MN008008A	ENCODER COUPLER		1	
32	1801045	ENCODER BRACKET		1	
33	MN0040	ENCODER		1	

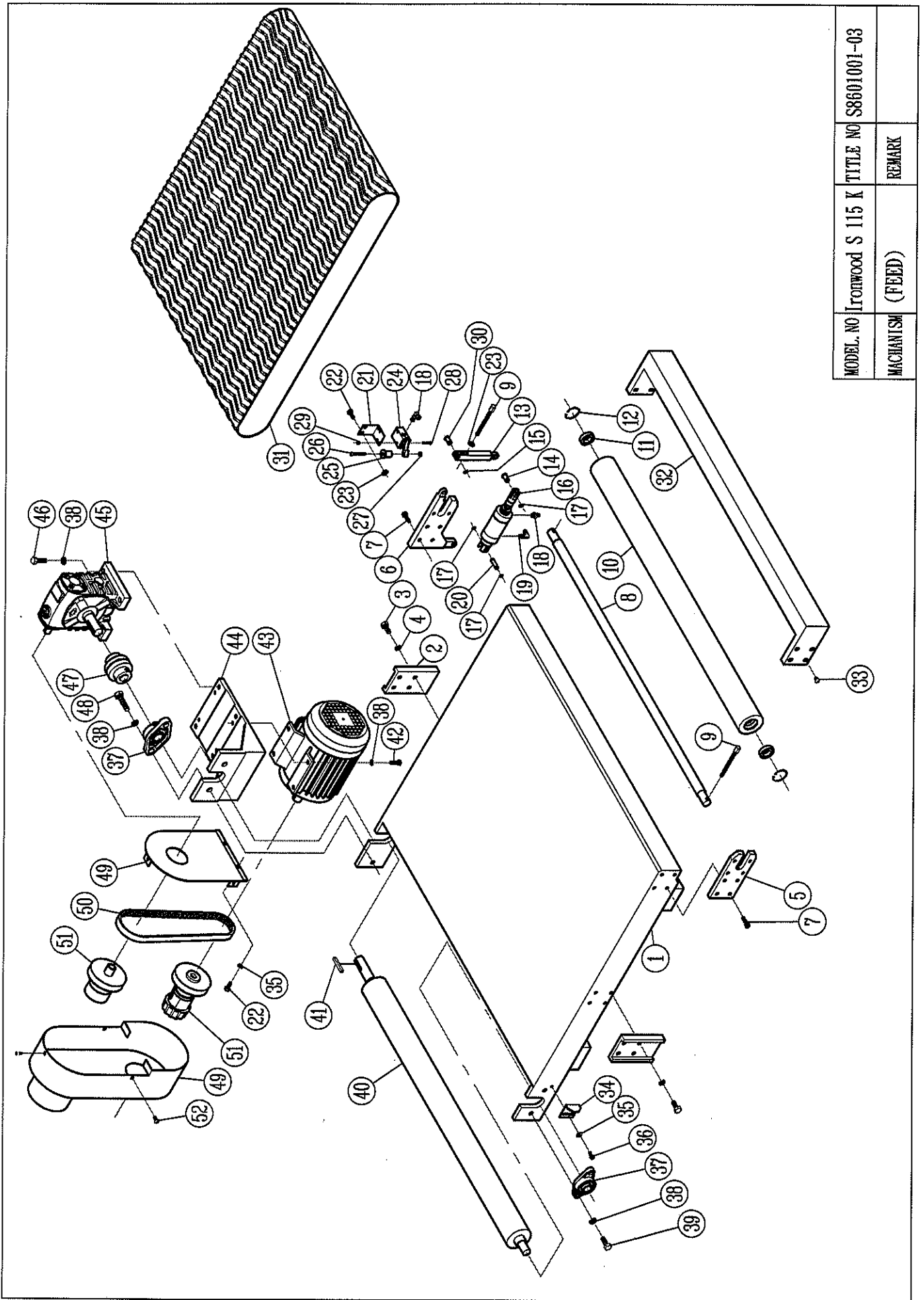

PRODUCT		WIDE BELT SANDERS		<u>PARTS LIST</u>	FILE NO.	S8601001-03
MODEL		Ironwood S 115 K			TOTAL PAGE	11
MECHANISM		FEED			REMARK	
NO.	PART NUMBER	PART PRODUCT		SPECIFICATION	Q. T. Y	
1	S8601009	TABLE			1	
2	0101014	TABLE SLIDE (INTERNAL)			2	
3	MS101025	HEX. HEAD BOLT		M10x25	8	
4	MS600110	LOCK WASHER		M10	8	
5	0101008	FRONT ROLLER BRACKET (L)			1	
6	0101009	FRONT ROLLER BRACKET (R)			1	
7	MS200825	HEX SOCKET CAP BOLT		M8x25	8	
8	S8601010	FRONT CONVEYOR ROLLER ROD			1	
9	M0101020	ADJUSTED SCREW			2	
10	S8601011	FRONT CONVEYOR ROLLER			1	
11	MB206005	BALL BEARING		6005LLB	2	
12	MG104717	RETAINING RING		R47	2	
13	0101010	CYLINDER BAR			1	
14	0101011	PIN(A)			1	
15	MG201210	RETAINING RING		S12	1	
16	MJ060425	CYLINDER		CM50x25CB+Y	1	
17	MG201010	RETAINING RING		S10	3	
18	MQ140202	SLINCER JOINT		1/4"凸頭	1	
19	MQ030122	L JOINT		1/4"x6mm	3	
20	0101012	PIN(B)			1	
21	5803030	VALVE BRACKET			1	
22	MS100820	HEX. HEAD BOLT		M8x20	8	
23	M3001002	SPACER			6	
24	MQ111000A	JOGGING VALVE		VM2(桿)	1	
25	M3001018	JOGGING GAIDE BUSHING			1	
26	MS000630	PAN HEAD BOLT		M6x30	1	
27	MS500600	NUT		M6	1	
28	MS000535	PAN HEAD BOLT		M5x35	2	
29	MS500500	NUT		M5	2	
30	3001077	PIN(C)			1	

PRODUCT		WIDE BELT SANDERS	<u>PARTS LIST</u>		FILE NO.	S8601001-03
MODEL		Ironwood S 115 K			TOTAL PAGE	11
MECHANISM		FEED			REMARK	
NO.	PART NUMBER	PART PRODUCT	SPECIFICATION	Q. T. Y		
31	MH650095A	CONVEYOR BELT	1270*2430	1		
32	S8601012	CONVEYOR BELT GUARD		1		
33	MS300812	M8x12		8		
34	1801043	ATTACH BRACKET		1		
35	MS610004	FLAT WASHER	M6	1		
36	MS206016	HEX SOCKET CAP BOLT	M6*16	1		
37	MA060206	BEARING UNIT	UCFL206	2		
38	MS600112	LOCK WASHER	M12	8		
39	MS101230	HEX HEAD BOLT	M12x30	2		
40	S8601014	REAR CONVEYOR ROLLER		1		
41	MK287040	KEY	8x7x40	1		
42	MS101240	HEX HEAD BOLT	M12x40	4		
43	MT0314	MOTOR	3HP	1		
44	S7403010	REDUCER BRACKET		1		
45	MD021004	WORM GEAR REDUCER	#100,1/40,HW	1		
46	MS101250	HEX HEAD BOLT	M12x50	2		
47	S3401023A	COUPLER	#97 ^{ø30} / _{ø38}	1		
48	MS101240	HEX HEAD BOLT	M12x40	4		
49	5303012	PULLEY GUARD		1		
50	MR080321	V-BELT	1422V-321	1		
51	ME2282521	SPEED VARIABLE PULLEY	APH,3HP	1		
52	MS000612	PAN HEAD BOLT	M6*12	3		

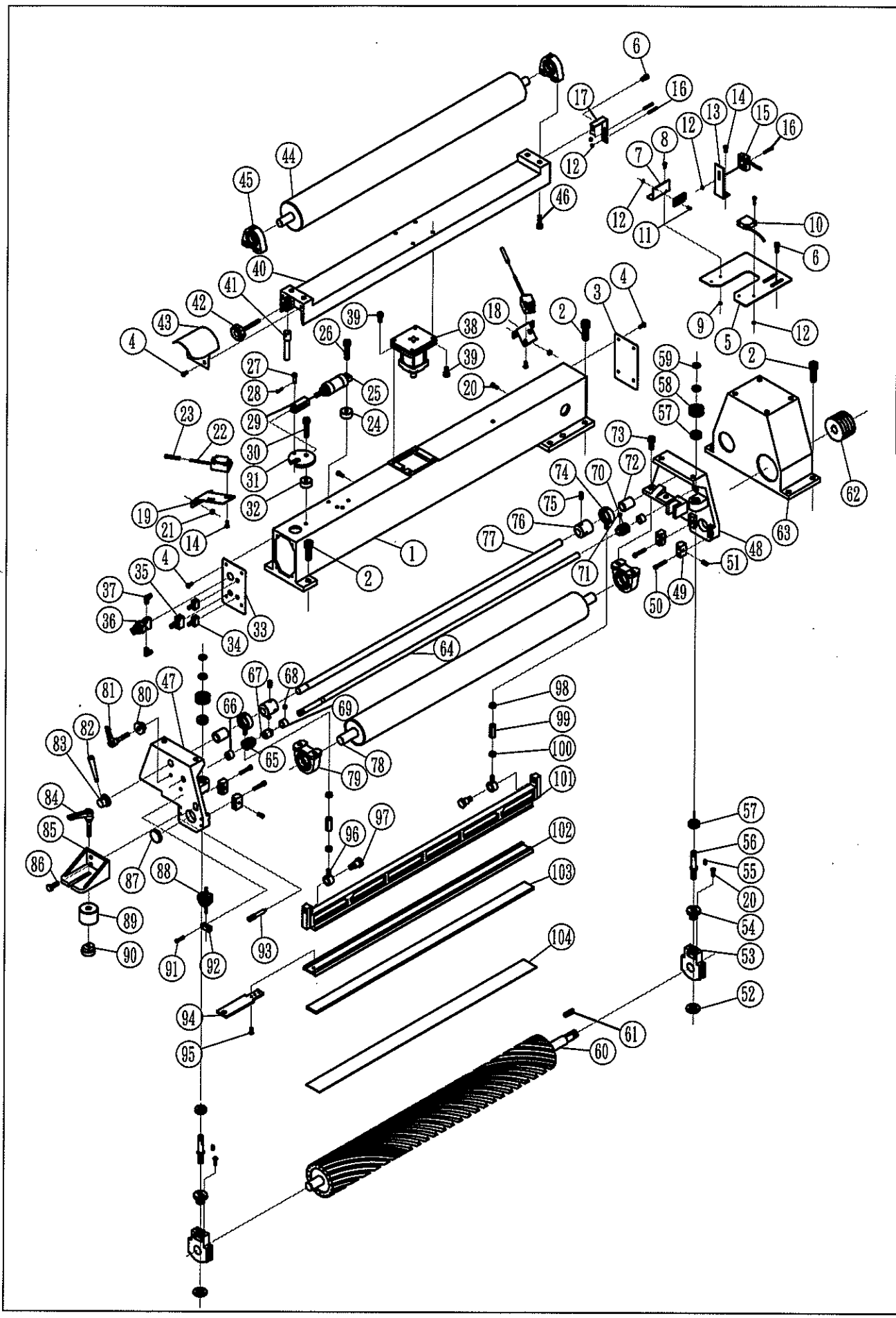

MODEL NO	Ironwood S 1155 K	TITLE NO	S8601001-04
MACHINISM	K ARM	REMARK	

PRODUCT		WIDE BELT SANDERS		FILE NO.		S8601001-04			
MODEL		Ironwood S 115 K		<u>PARTS LIST</u>		TOTAL PAGE		11	
MECHANISM		K ARM		REMARK					
NO.	PART NUMBER	PART PRODUCT		SPECIFICATION		Q. T. Y			
1	8005002	MAIN FRAME (K)				1			
2	MS201645	HEX. SOCKET CAP BOLT		M16x45		19			
3	3002022Z	MAIN FRAME PLATE (R)				1			
4	MS000612	PAN HEAD BOLT				10			
5	3002037	PHOTOELECTRIC SWITCH BRACKET				1			
6	MS100830	HEX. HEAD BOLT		M8x30		2			
7	1204008A	REFLECTION MIRROR BRACKET				1			
8	MS000512	PAN HEAD BOLT		M5x12		2			
9	MS500500	NUT		M5		2			
10	MN110004	PHOTOELECTRIC SWITCH				1			
11	MS000410	PAN HEAD BOLT		M4x10		2			
12	MS500400	NUT		M4		2			
13	1001050A	LIMIT SWITCH BRACKET				1			
14	MS000610	PAN HEAD BOLT		M6x10		2			
15	MN065106A	LIMIT SWITCH		7166		1			
16	MS000440	PAN HEAD BOLT		M4x40		2			
17	3001066	BRACKET				1			
18	3002040	LIMIT SWITCH BRACKET (R)				1			
19	3002038	LIMIT SWITCH BRACKET (L)				1			
20	MS200616	HEX. SOCKET CAP BOLT		M6x16		8			
21	MS500600	NUT		M6		4			
22	MN065106A	LIMIT SWITCH		5106		2			
23	MO105106	MAGNETIC SLEEVE				2			
24	5806005	SPACER				1			
25	MJ070205	CYLINDER		300x5SD		1			
26	MS201245	HEX. SOCKET CAP BOLT		M12x45		1			
27	3002018	PIN				1			
28	MK070106	CATTER PIN				1			
29	3002016	CONNECTED BLOCK				1			
30	MS201250	HEX. SOCKET CAP BOLT		M12x50		1			

PRODUCT		WIDE BELT SANDERS	<u>PARTS LIST</u>		FILE NO.	S8601001-04
MODEL		Ironwood S 115 K			TOTAL PAGE	11
MECHANISM		K ARM			REMARK	
NO.	PART NUMBER	PART PRODUCT	SPECIFICATION	Q. T. Y		
31	3002019	ECCENTRIC PLATE		1		
32	3002017	SPACER		1		
33	5305002	MAIN FRAME PLATE (L)		1		
34	MQ080101	VALVE	1/8	2		
35	MQ080102	VALVE	1/4	1		
36	MQ030122	SPEED ADJUSTED NUT	1/8	2		
37	MQ100100	SELECTED SWITCH		1		
38	MJ020650A	CYLINDER	AS80*50FA2	1		
39	MS201020	HEX SOCKET CAP BOLT	M10x20	8		
40	8005007	UPPER ROLLER BRACKET		1		
41	3002021	ADJUSTED SHAFT		1		
42	M0024000	KNOB		1		
43	3303011	ROLLER GUARD		1		
44	8005009	UPPER ROLLER		1		
45	MA140207	BEARING UNITS	UKPA207	2		
46	MS201445	HEX SOCKET CAP BOLT	M14x45	4		
47	7005003	FEED ROLLER BRACKET (L)		1		
48	7005004	FEED ROLLER BRACKET (R)		1		
49	3202016Z	BEARING SLIDE RAIL		4		
50	MS201045	HEX SOCKET CAP BOLT	M10x45	8		
51	MS400820	SET SCREW	M8x20	4		
52	MB60005	LOCK NUT	AN05	2		
53	3202004Z	BEARING UNITS	UCT207	2		
54	3202005Z	HOIST NUT		2		
55		KEY	6x6x20	2		
56	3202007Z	HOIST STUD		2		
57	MB051103	BALL TRUST BEARING	51103	2		
58	3202008Z	WORM WHEEL		2		
59	MB60003	LOCK NUT	AN03	2		
60	S8005005	FEED ROLLER		1		

PRODUCT		WIDE BELT SANDERS		<u>PARTS LIST</u>		FILE NO.	S8601001-04
MODEL		Ironwood S 115 K				TOTAL PAGE	11
MECHANISM		K ARM				REMARK	
NO.	PART NUMBER	PART PRODUCT		SPECIFICATION	Q. T. Y		
61		KEY		14x9x50	1		
62	S3402007	PULLEY			1		
63	3201002Z	MAIN FRAME BRACKET			1		
64	8005012	HOIST ADJUSTED ROD			1		
65	3002011Z	CLUTCH WORM ROD			1		
66	3002012Z	SET COLLAR			2		
67	3002013Z	CLUTCH BUSHING			1		
68	MS400808	SET SCREW		M8x8	1		
69	3002019Z	SET COLLAR			1		
70	3002010Z	HOIST WORM ROD			1		
71	MS400810	SET SCREW		M8x10	1		
72	5805030	SET SPACER			2		
73	MS201250	HEX. SOCKET CAP BOLT		M12x50	4		
74	5805022	UPPER ADJUSTED SCREW			2		
75	MS400812	SET SCREW		M8x12	1		
76	5805027	ECCENTRIC COLLAR			2		
77	8005008	GUIDE ROD			1		
78	8005006	LOWER ABRASIVE ROLLER			1		
79	MA040207A	BEARING UNITS		UCPA207	1		
80	3202045	LOCK PIECES			1		
81	MS8212060	LOCK HANDLE		M10*60	1		
82	3202046	HOIST BUSHING BAR			1		
83	3202044	HOIST BUSHING			1		
84	MS810834A	LOCK HANDLE		1/2X3-1/2	1		
85	5401018	SUPPORTED BLOCK			1		
86	MS201030	HEX. HEAD BOLT		M10x30	4		
87	3202017Z	STEEL PLUG			1		
88	MO05005B	DIAL INDICATOR		5MM	1		
89	0103025	SUPPORTED BLOCK			1		
90	2601020	BLOCK			1		

PRODUCT		WIDE BELT SANDERS		FILE NO.		S8601001-04			
MODEL		Ironwood S 115 K		<u>PARTS LIST</u>		TOTAL PAGE		11	
MECHANISM		K ARM				REMARK			
NO.	PART NUMBER	PART PRODUCT	SPECIFICATION		Q. T. Y.				
91	MS200525	HEX. SOCKET CAP BOLT	M5x25		4				
92	3002018Z	INDICATOR BRACKET			1				
93	5807014	STUD	(B)		1				
94	5404008	STAND HOOK			1				
95	MS000612	PAN HEAD BOLT	M6x12		3				
96	5803025	LOWER ADJUSTED STUD			2				
97	3202047	LOCATED BOLT			2				
98	MS501000-1	NUT	M10-LH		2				
99	3202050	ADJUSTED NUT			2				
100	MS501000	NUT	M10		2				
101	8005011	SANDING STAND (UPPER)			1				
102	8005022	SANDING STAND (LOWER)			1				
103		WOOL PAD			1				
104		CARBONIC PAD			1				

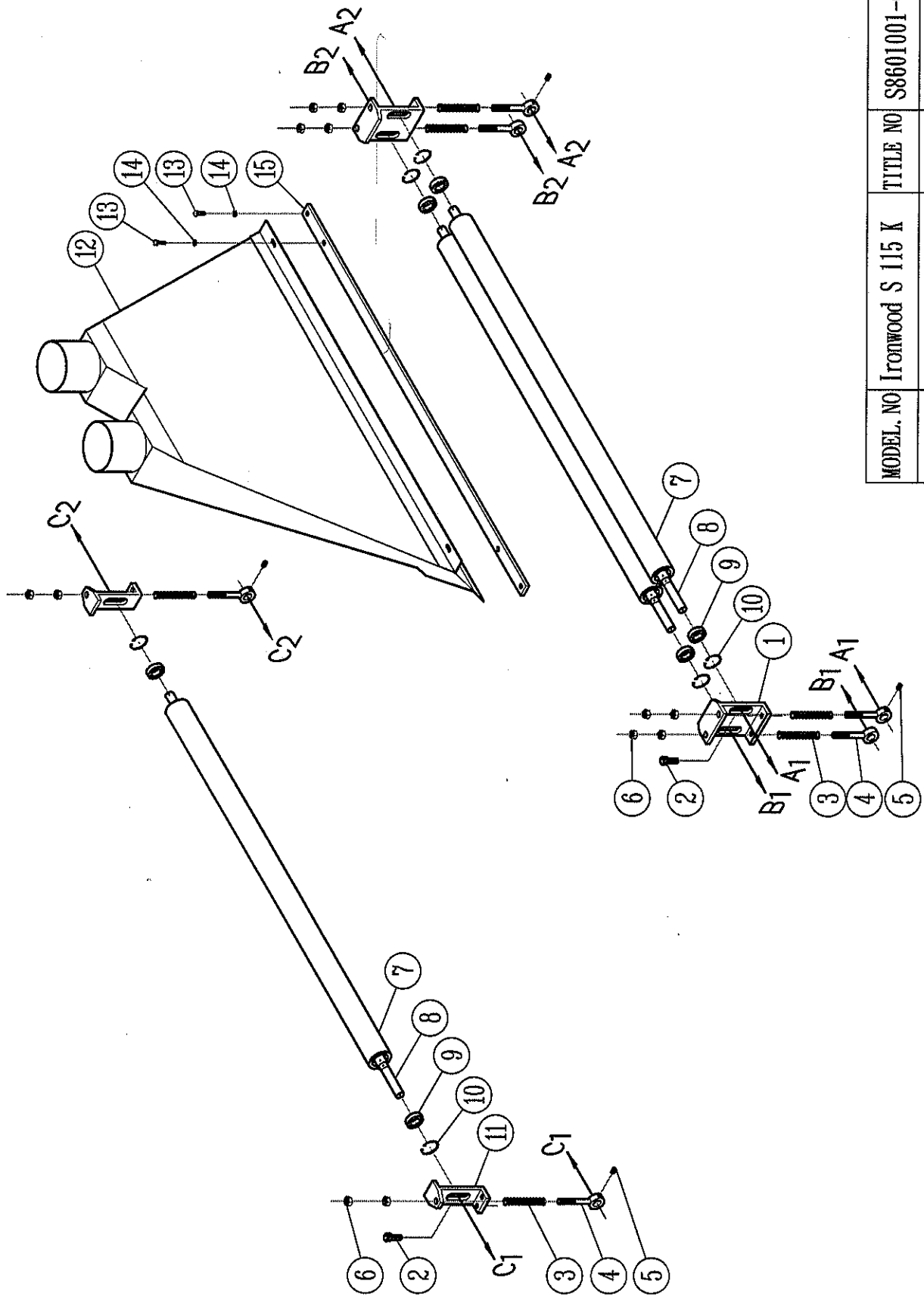

MODEL. NO	Ironwood S 115 K	TITLE NO	S8601001-05
MACHANISM	(PRESS)	REMARK	

PRODUCT	WIDE BELT SANDERS	<u>PARTS LIST</u>	FILE NO.	S8601001-05
MODEL	Ironwood S 115 RK		TOTAL PAGE	11
MECHANISM	PRESS		REMARK	

NO.	PART NUMBER	PART PRODUCT	SPECIFICATION	Q. T. Y
1	2303029	PRESS ROLLER		2
2	MS201025	HEX SOCKET CAP BOLT	M10x25	8
3	M5807033	COIL SPRING	1/2"	6
4	3002031	STUD	1/2"	6
5	MS400812	SET SCREW	M8*12	6
6	MS510800	NUT	1/2"	12
7	8007001	PRESS ROLLER		3
8	8007002	PRESS ROLLER ROD		3
9	MB206004	BALL BEARING	6004LLB	6
10	MG104217	RETAINING RING	R42	6
11	2303030	PRESS ROLLER		2
12	8002001	DUST HOOD		1
13	MS101025	HEX HEAD BOLT	M10x25	4
14	MS600110	LOCK WASHER	M10	4
15		FAIXED PLATE		1

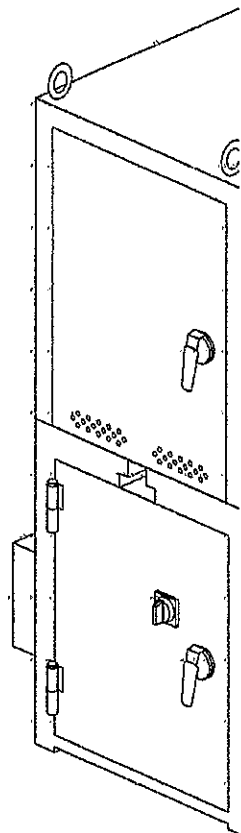

IRONWOOD

Version A
March 2015

© 2015 Stiles Machinery Inc.

stiles

Stiles Machinery Inc.
3965 44th St. SE
Grand Rapids, MI 49512
p. 616.698.7500
f. 616.698.9411
www.stilesmachinery.com