

# PHM.30

## Pocket Hole Machine



**Attention: Read this manual before using your machine.**

## 1. INSTRUCTION MANUAL

### 1.1. Please read all instructions prior to attempting to use the PHM.30.

The images in this manual are illustrative and are meant to demonstrate the correct operation of your product.

**Note:** Instruction manual images may vary slightly from actual product.

**CAUTION:** When servicing, use only identical replacement parts.

### 1.2. Specifications:

Power: 2,400 W

Wood Thickness Limit: 1/2" - 1-9/16"

Amperage: 19 A

Drill: High-speed steel 9/64"

Cutter: 1/4"

Volts: 127 V

Air Pressure: 6 bar (87 Psi)

Dimensions: 25-5/8" x 30" x 42-1/2"

Net Weight: 165.4 Lbs (75 Kg)

Gross Weight: 243.6 Lbs (110.50 Kg)

CBM: 760 x 840 x 1270 mm

(29-59/64" x 33-5/64" x 50")

## 2. GROUNDING INSTRUCTIONS

**2.1. THIS PHM.30 HOLE MACHINE MUST BE CONNECTED TO A GROUNDED WIRING SYSTEM** or to a system with an equipment-grounding conductor. In the event of a malfunction, grounding provides a path of least resistance for electric current to reduce the risk of electric shock. This PHM.30 hole machine is equipped with an electric cord including an equipment-grounding conductor and a grounding plug. The plug must be connected into a matching outlet provided. If it will not fit the outlet; have the proper outlet installed by a qualified professional. Improper connection of the equipment-grounding conductor can result in a risk of electric shock and/ or malfunction. If repair or replacement of the electric cord or plug is necessary, do not connect the equipment-grounding conductor to a live terminal. Check with a qualified professional if the grounding instructions are not completely understood or if to whether the PHM.30 hole machine is properly grounded. Use only 3-wire extension cords that have 3-prong grounding plugs and 3-pole receptacles that accept the PHM.30 hole machine's plug.

**2.2. REPAIR OR REPLACE A DAMAGED OR WORN CORD IMMEDIATELY.** When servicing use only identical replacement parts.

**2.3. USE PROPER EXTENSION CORD.** Make sure your extension cord is in good condition. When using an extension cord, be sure to use one properly equipped to carry the current your PHM.30 hole machine will draw. An undersized cord will cause a drop in line voltage resulting in loss of power and overheating. For cord length of up to 50 feet, use a cord of 14 gauge. For a cord length of 50 to 100 feet, use a cord of 12 gauge. A cord length over 100 feet is not recommended. If in doubt, use the next heavier gauge. Smaller the gauge number, heavier the cord.

**2.4. IMPORTANT:** Do not use an extension cord with length above 20 meters.

| Cable 2 wires        |          | Cable 3 wires        |          |
|----------------------|----------|----------------------|----------|
| Ø (mm <sup>2</sup> ) | Amperage | Ø (mm <sup>2</sup> ) | Amperage |
| 0,5                  | 9        | 0,5                  | 8        |
| 1,0                  | 13       | 1,0                  | 12       |
| 1,5                  | 16,5     | 1,5                  | 15       |
| 2,5                  | 23       | 2,5                  | 20       |

**2.5.** The PHM.30 hole machine has a grounding plug similar to the plug illustrated in Fig. 1. Make sure the PHM.30 hole machine is connected to an outlet having the same configuration as the plug. No adapter is available or should be used with this PHM.30 hole machine. If the machine must be reconnected for use on a different type of electric circuit, the reconnection should be made by a qualified professional; and after reconnection, the PHM.30 hole machine should comply with all local codes and ordinances.

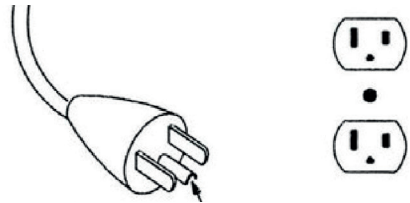

**Fig.1**

### 3. ASSEMBLY

**3.1.** You will receive your machine palletted.



**3.2.** Remove the screws that secure the machine to the pallet inside machine.

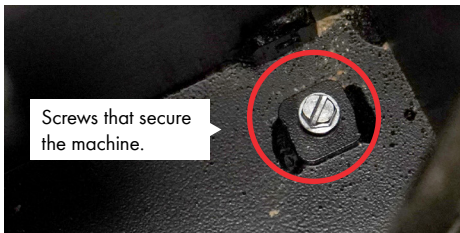

**3.3.** Remove the machine from the pallet with all included parts and accessories.



- 1** - Wrench 15/16" (24 mm)
- 2** - Wrench 43/64" (17 mm)
- 3** - Template for adjusting the router
- 4** - Feet
- 5** - Base bolt
- 6** - Screw and washer
- 7** - Template for adjusting the 1 HP router
- 8** - Template for adjusting the 2.25 HP router

**3.4.** Place the adjustable feet and position the machine upright on the floor. Set the positioning of the feet until the machine is level, then tighten the nuts next to the plate, as shown below:

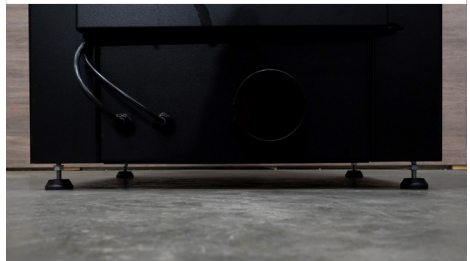
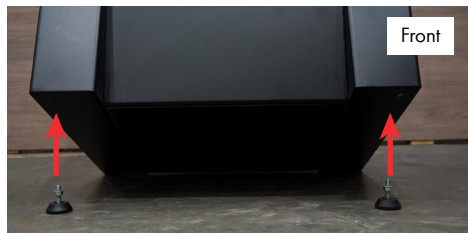

**3.5.** It is possible to anchor the machine on the floor. To do this, align the base screw on the floor and secure it to the machine and the floor. We recommend bolting the machine mainly for use on large workpieces.

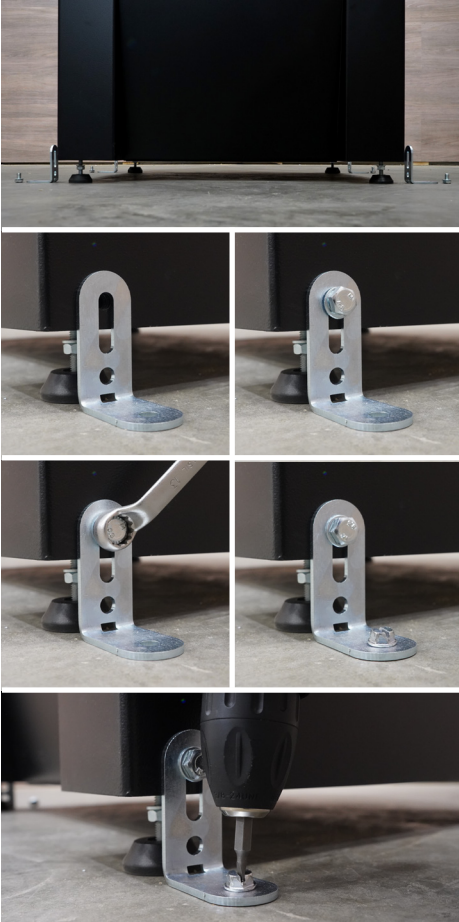

#### 4. ADJUSTMENTS

**4.1.** Choose a 1/4" hose with a pressure of 6 bar (90 psi) and fit the connector behind the machine.

**4.1.1. ATTENTION:** Use filtered compressed air.

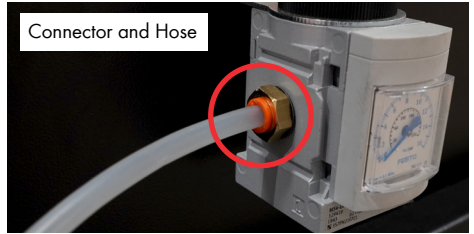

**4.2.** At the front of the machine, unlock the top and lock it to check for roughages. Make sure the handle is locked.

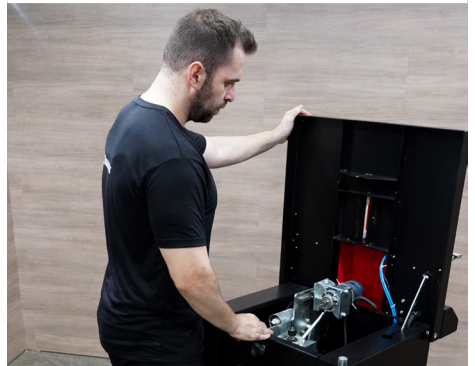

**4.2.1.** Be sure to lock the table.

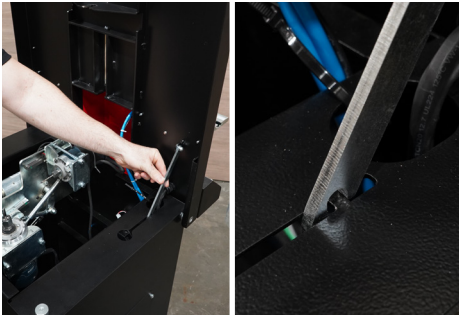

**4.3.** With the table top open and locked, check that the router bits are at the correct height as per the templates.

**4.3.1. Note:** To change the height of the drills, check the router manual.

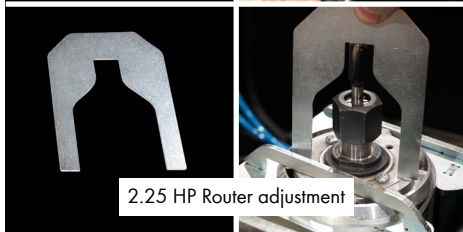
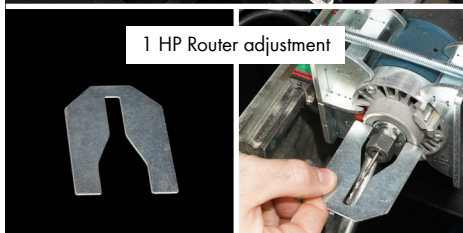
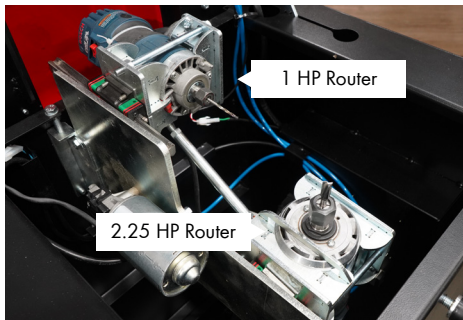

**4.4.** Make sure the routers are securely attached. Maximum torque must be 3.0 Nm.

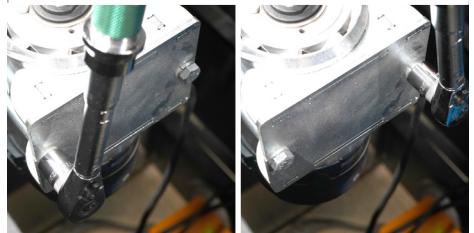
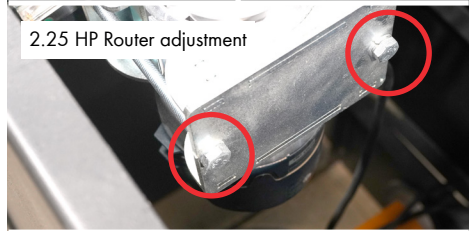
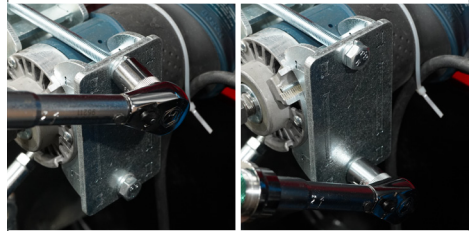
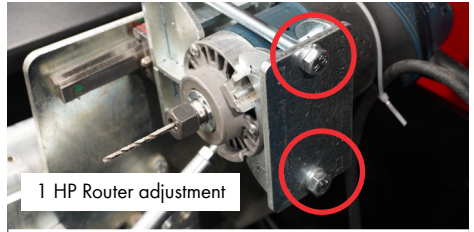

**4.5.** Make sure the routers are on.

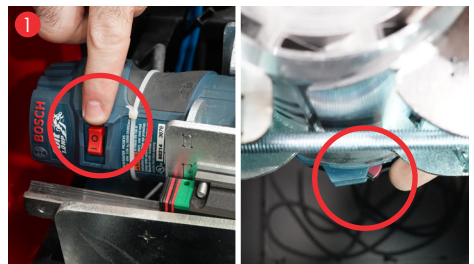

**4.6.** Choose the value unit (centimeters or inches) of the depth of cut scale. To change the position of the scale, simply unscrew, reverse position, and screw again.

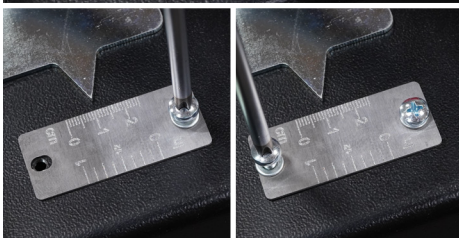
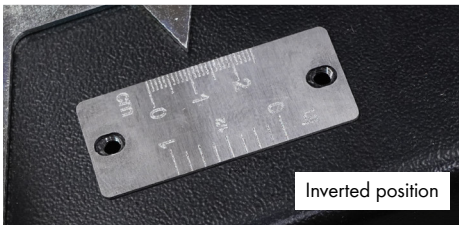
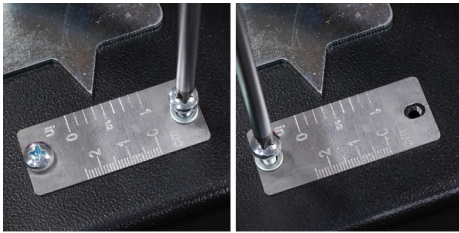

**4.7.** The table has two sides for use. One smooth side and another side with sandpaper. Choose the side of the table you want to use. To do this, simply unscrew the table, turn it over and screw again.

**4.7.1.** When Working with coated wood use smooth side. When working with non-coated wood use abrasive side.



**4.8.** To adjust the laser guide, loosen the screw and align the laser guide left or right. Once the Laser is centered, tighten the screw.

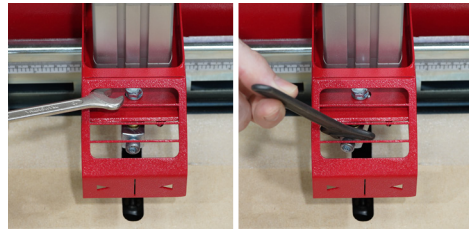

**4.9.** Connect a Dust Collector (minimum 1 HP) to the machine. The port diameter is 4".



## 5. OPERATIONS

**5.1.** The operations made by the PHM.30 hole machine, as well as any other machine, can pose risks to the operator if the instructions in this section are not taken into account. These instructions are written with the understanding that the operator has the knowledge and skills necessary to operate this machine. If at anytime you're having difficulty performing any operation, stop using the machine. If you are an inexperienced operator, we recommend that you read books, technical papers, or seek training from an experienced operator before performing any unfamiliar operation. The machine must operate with all the protections and security systems that comes standard.

**5.2.** Loosen the depth scale knobs and choose the distance you want from the base of the workpiece to the beginning of the tear. After that tighten the knobs.

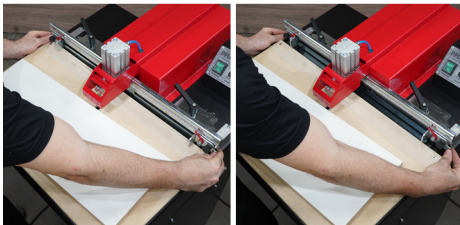
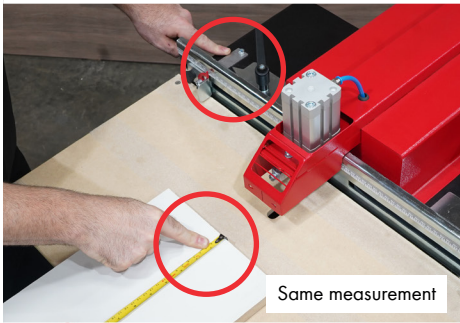
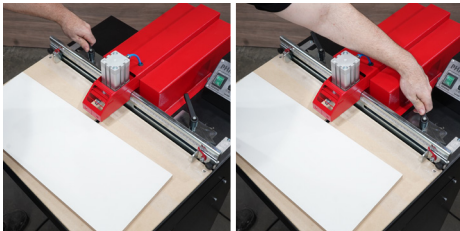

**5.3.** Choose the size you want from the tear, to the side of the workpiece. Then tighten the knobs.

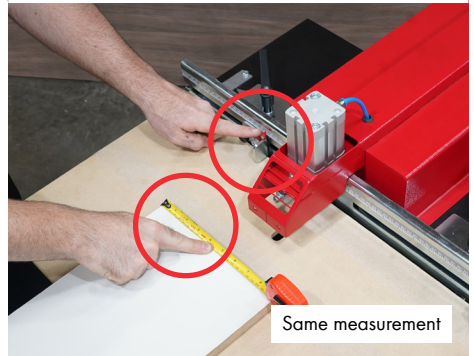
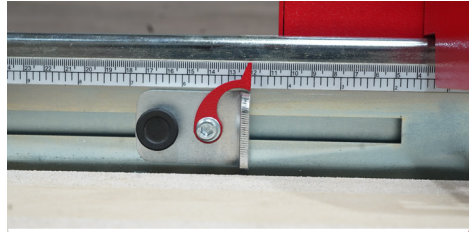

**5.4.** Plug in the machine.



**5.5.** Turn GENERAL switch ON.



**5.6.** Turn LASER switch ON.



**5.7.** Set the Feeder to the type of wood you are working with.

**5.7.1.** The denser the wood, the slower the feeder must be..



**5.8.** Position the workpiece.



**5.9.** Press the pedal until the operating cycle is complete.

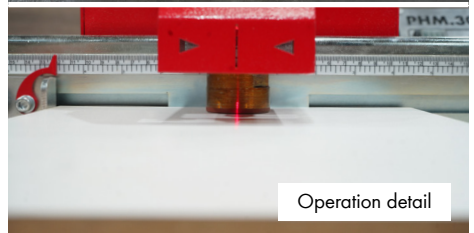
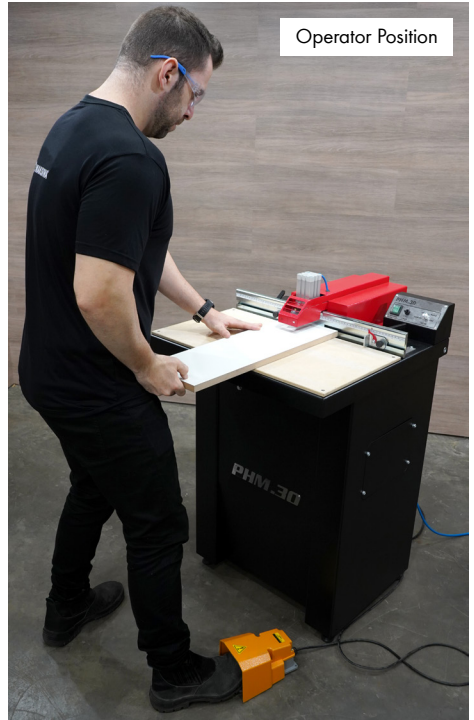
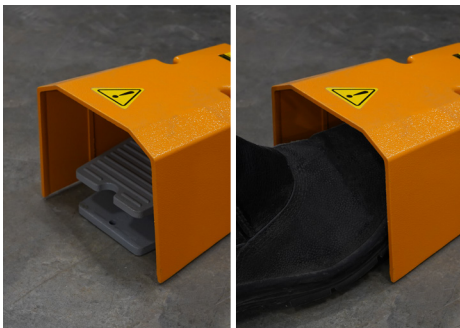

**5.10.** Final result.





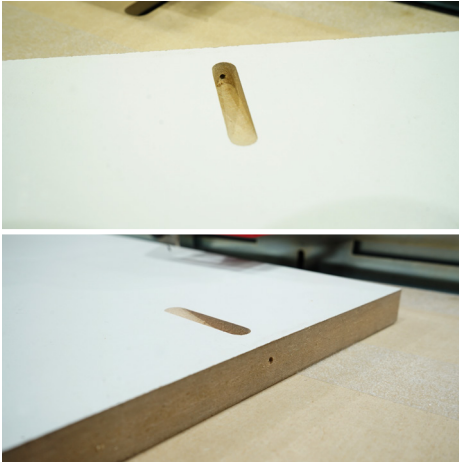

## 6. MAINTENANCE

**6.1. IMPORTANT:** All maintenance or repairs of the machine should be done with the machine **OFF** and unplugged from the outlet to prevent accidental electrocution or a short circuit.

### 6.2. GENERAL:

Periodic maintenance on your PHM.30 hole machine will ensure optimum performance. Make it a habit to inspect your PHM.30 hole machine every time you use it. This section covers the service adjustments or common procedures that may need to be made during the life of your machine. Verify if the following conditions for repair or replacement are needed:

- Loose screws.
- Switches or buttons damaged.
- Keep drills and cutters sharp.
- Keep the height of the routers aligned.
- Make sure the routers are securely attached.
- Check, cables, plugs and sockets for wear or Damage.
- Transmission chain damaged.
- Any other condition that could adversely affect the safe operation of the equipment.

## 7. GENERAL SAFETY INSTRUCTIONS FOR ALL EQUIPMENT

**7.1.** Keep a clean work surface. Cluttered areas and work surfaces can contribute to accidents.

**7.2.** Do not use the PHM.30 hole machine in hazardous environments. Do not use machine in damp or wet locations or exposed to rain.

**7.3.** Keep work area well-lit.

**7.4.** Keep children away. Visitors should be kept at a safe distance from work area.

**7.5.** Do not overreach on the equipment. Maintain balance and keep your feet in a comfortable position at all times.

**7.6.** Keep all tools in order. Keep tools sharp and clean for better and safer performance. Follow the instructions for lubricating and changing accessories.

**7.7.** Unplug the machine before servicing or changing accessories such as scissors, cutters etc.

**7.8.** Reduce the risk of unintentional starting. Ensure that the switch is in the "OFF" position before connecting the plug wires.

**7.9.** Use recommended accessories. See the instruction manual for a list of recommended accessories. Improper use of accessories may cause risk of injury to person (s).

**7.10.** Never step or stand on the machine. A serious accident may occur if the machine is dented or if parts are accidentally touched.

**7.11.** Check for damaged parts, before continuing the use of the PHM.30 hole machine, a guard or other part that is damaged should be examined carefully to determine whether its ability to perform its function properly has been affected. Check the alignment of moving parts, wear of parts, mounting and any other condition that may affect its operation. If any part is damaged and must be replaced do so immediately. Do not attempt to repair/replace any parts unless the machine is off and unplugged.

- 7.12.** Never leave a running tool unattended.
- 7.13.** The motor of this machine can emit sparks, and react with flammable gases.
- 7.14. CAUTION:** FAILURE TO ADHERE TO THESE WARNINGS MAY RESULT IN PERSONAL INJURY AND SERIOUS DAMAGE TO THE MACHINE.

**7.15. ALWAYS USE PROPER PROTECTIVE EQUIPMENTS TO OPERATE THIS MACHINE.**



- 7.16.** Always use safety glasses. Also use face or dust mask if cutting operation is dusty. Everyday eyeglasses only have impact resistant lenses, they are NOT safety glasses.
- 7.17.** Keep guards in place and working order.
- 7.18.** Protect the electric power supply line with at least a 20 amp fuse or a circuit breaker switch.
- 7.19.** Make sure that the router is turning in the proper direction.
- 7.20.** Make sure that the knobs and screws are properly tightened and secure before starting any operation.
- 7.21.** Keep tool clean and in good working condition.
- 7.22.** It is recommended wearing shoes with non-slip soles. Use protection for hair in order to avoid becoming caught in moving parts.
- 7.23.** Use appropriate equipment. Do not wear loose clothing, gloves, chains, rings, bracelets or other accessories that could become caught in moving parts.
- 7.24.** Keep vents free of debris.
- 7.25.** Keep hands away from moving or sharp parts.
- 7.26.** In case the wood is too long, support the ends on the sides of the machine to prevent warping.

- 7.27.** Do not attempt to operate the machine in another voltage beyond designated.
- 7.28.** Do not use other tools than recommended.
- 7.29.** Do not apply lubricant to the tools during use.
- 7.30.** Do not operate without all parts of the machine properly assembled.
- 7.31.** Do not use lubricants or cleaners (particularly sprays and aerosols) in the vicinity of the plastic guard. The polycarbonate material used in the guard is sensitive to certain chemicals.

**7.32. WARNING:** Some dust created by the act of sanding, cutting, grinding, drilling and other construction-related activities contains chemicals that can cause cancer, birth defects or other reproductive harm. Some examples of these products are: Leadbased paint; crystal silica bricks, concrete and other masonry products; and arsenic and chromium from chemically treated wood.

**7.33. CAUTION:** Do not connect the unit to the power outlet until all instructions have been read and understood. Always tighten the adjustment tabs before using the machine. Think: "How can I prevent accidents?".

**7.34. ELECTRICAL CONNECTION**

The PHM.30 hole machine has 1-phase 127V motor. To avoid burning risk, check the voltage of your outlet before starting the machine. If necessary, make the change to your power source with the help of a qualified professional.

**7.34.1.** Ensure that your power supply is in accordance with that designated on the board. A 10% decrease/increase in voltage will cause loss of power or overheating. All machines are tested at the factory. If this machine does not turn on, check the electricity supply.

**7.34.2.** Check the compatibility of your outlet and plug in the machine.

**7.34.3.** Do not do patches and adaptations.

**7.34.4.** To avoid electrical shock and damage to the equipment always ground the machine.

### 7.35. FAMILIARIZATION

Place the machine on a smooth, flat surface. Check the pictures and watch the descriptions in this manual to familiarize yourself with all parts and locations.

## 8. WARRANTY TERMS

**8.1.** Maksiwa assures the owner of his equipment, identified by the date of issue of the purchase invoice, a warranty of two (2) years, as follows:

**8.2.** The warranty period begins on the date of the commercial invoice.

**8.3.** Within the warranty period, the hand labor and the components replaced by manufacturing defect will be provided for free as long as duly proved by Maksiwa.

**8.4.** Third-party manufacturing equipment that makes up the Maksiwa equipment (such as motors, electrical equipment, belts etc.) are subject to the terms and conditions of warranty of their respective manufacturers.

**8.5.** In the case of a warranty exchange, please return the defective part to the manufacturer urgently.

**8.6.** Costs and risks of transport will be assumed by the machine owner.

**8.7.** Equipment installation expenses and workplace adaptations are due to the machine owner.

**8.8.** When you notice any defect or malfunction when receiving the equipment, get in touch immediately with the manufacturer or dealer. Do not turn it on.

**8.9.** Not included in this warranty are technical visits aimed at cleaning or adjustments caused by wear, resulting from normal use of the equipment.

**8.10.** The warranty does not cover problems caused by mistreatment, carelessness, misuse of the functions designed for this equipment in this manual, as well as poorly executed operations by untrained operators.

**8.11.** Maksiwa is not responsible for lost productivity, direct or indirect damages caused to the owner of the equipment or to third parties, or any other expense, including lost profits.

**8.12.** Even under warranty, you may lose its validity as follows:















- a) Application of non-original components;
- b) Alteration of its original features;
- c) Lack of proper maintenance;
- d) Improper use of the equipment;
- e) Change in equipment or electronic connections;
- f) Damage caused by mechanical shock or exposure to unsuitable conditions (humidity, salt spray, corrosive agents, etc.);
- g) Damage caused by bad weather (floods, flooding, lightning, power outages etc.).

For any further assistance, contact us at:

Tel: **+1 (844) 319-6594**

E-mail: **customer.service@maksiwa.com**

## 9. ENABLE HEAT AND CONTROL

|  |                      |   |                   |   |                 |   |                |
|--|----------------------|---|-------------------|---|-----------------|---|----------------|
|  | XC1 - MAIN CONNECTOR |  | POWER MAIN SWITCH |  | DC POWER 24 VCC |  | RESISTOR       |
|  | DIODO LASER          |  | POTENCIOMETER     |  | SOLENOIDE VALVE |  | PWM CONTROLLER |
|  | POWER PLUG           |  | LIMIT SWITCH NC   |  | LIMIT SWITCH NO |  | PEDAL NC       |
|  | PEDAL NO             |  | MOTOR CC          |   |                 |   |                |

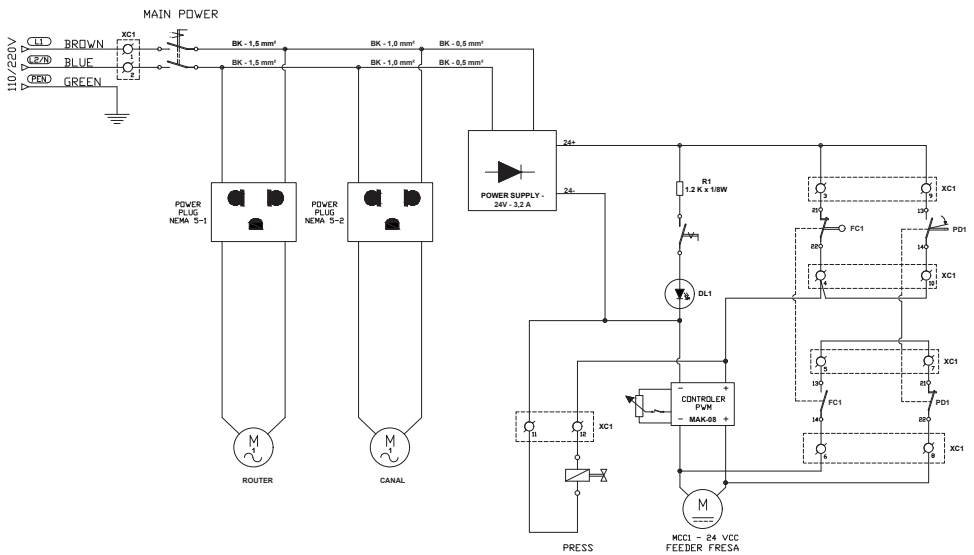

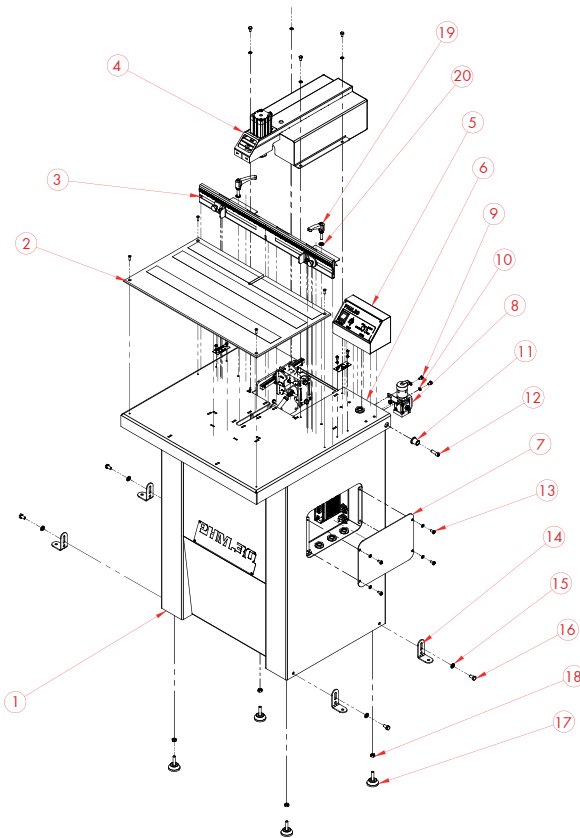
**10. PHM.30 HOLE MACHINE EXPLODED VIEW**

| No | Description                                | Qty | No | Description                                 | Qty |
|----|--|-----|----|---|-----|
| 1  | HOLE MACHINE BODY                          | 1   | 11 | TABLE ARTICULATOR SHAFT                     | 2   |
| 2  | WOOD TABLE WITH SANDER                     | 1   | 12 | TAP BOLT M8X25 ZINC PLATED STEEL PITCH 1,25 | 2   |
| 3  | DEPTH SCALE WITH KNOBS                     | 1   | 13 | PHILLIPS HEAD PAN SCREW M6X12 PICTH 1,0     | 4   |
| 4  | PROTECTION AND CYLINDER SET                | 1   | 14 | BASE BOLT                                   | 4   |
| 5  | PANEL CONTROL                              | 1   | 15 | HEX NUT M8                                  | 4   |
| 6  | TABLE SET                                  | 1   | 16 | TAP BOLT M8X16 ZINC PLATED STEEL PITCH 1,25 | 4   |
| 7  | ELECTRIC BOX COVER                         | 1   | 17 | FOOT LEVEL 4013 M8X30                       | 4   |
| 8  | PRESSURE REGULATOR SET                     | 1   | 18 | HEX NUT M8 ZINC PLATED STEEL PITCH 1,25     | 4   |
| 9  | TAP BOLT M6X10 ZINC PLATED STEEL PITCH 1,0 | 6   | 19 | DEPTH SCALE KNOBS                           | 2   |
| 10 | HEX NUT M6 ZINC                            | 10  | 20 | HEX NUT M8 ZINC                             | 12  |

## 11. ROUTERS EXPLODED VIEW

| No | Description          | Qty |
|----|----------------------|-----|
| 1  | ROUTER BOSCH 1,0 HP  | 1   |
| 2  | DRILL ADAPTER        | 1   |
| 3  | DRILL                | 1   |
| 4  | ROUTER BOSCH 2,25 HP | 1   |
| 5  | PHM.30               | 1   |

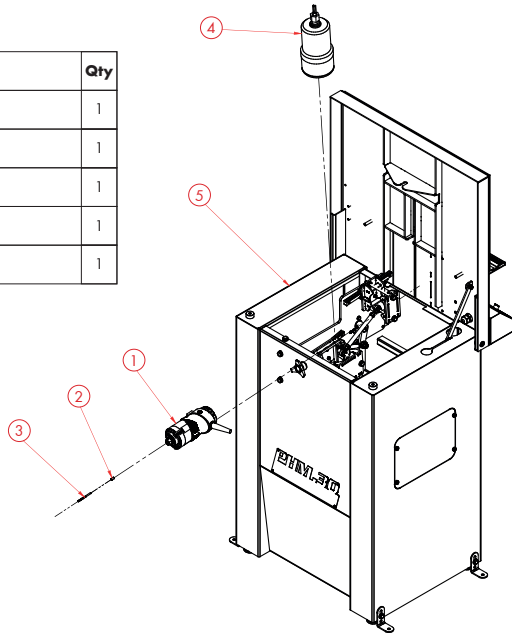

## 12. PROTECTION AND CYLINDER SET EXPLODED VIEW

| No | Description                                  | Qty |
|----|--|-----|
| 1  | PROTECTION SET                               | 1   |
| 2  | TAP BOLT M6X10 ZINC PLATED STEEL PITCH 1,0   | 4   |
| 3  | PISADOR SET                                  | 1   |
| 4  | LASER SUPPORT                                | 1   |
| 5  | ADN-40-40-A-PPS-A                            | 1   |
| 6  | STRAIGHT CONNECTION QUICK SCREW 1/4" HOSE 6" | 2   |
| 7  | THREAD GUIDE                                 | 1   |
| 8  | HEX NUT M6 ZINC                              | 4   |

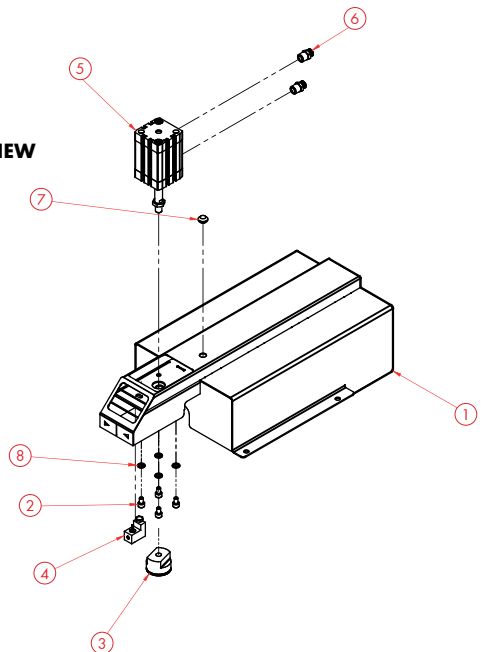

### 13. SYSTEM CUTTER EXPLODED VIEW

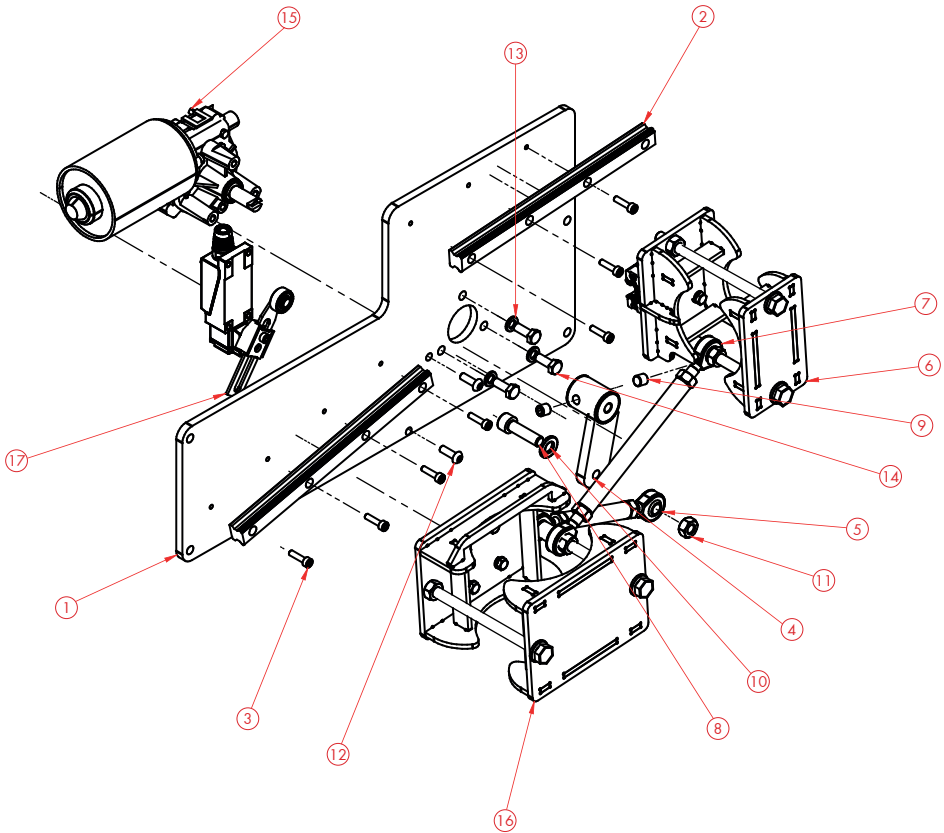

| No | Description                                 | Qty | No | Description                                | Qty |
|----|---|-----|----|--|-----|
| 1  | CUTTING SYSTEM MAIN SUPPORT                 | 1   | 10 | HEX NUT M8                                 | 1   |
| 2  | RAIL GUIDE                                  | 2   | 11 | HEX NUT M8 ZINC PLATED STEEL PITCH 1,25    | 1   |
| 3  | TAP BOLT M4X16 ZINC PLATED STEEL PITCH 0,7  | 7   | 12 | TAP BOLT M5X16 ZINC PLATED STEEL PITCH 0,8 | 2   |
| 4  | CUTTING SYSTEM ENGINE CONNECTING ROD        | 1   | 13 | HEX NUT M6                                 | 3   |
| 5  | CUTTING SYSTEM MINOR STEM                   | 1   | 14 | TAP BOLT M6X16 ZINC PLATED STEEL PITCH 1,0 | 3   |
| 6  | ROUTER SUPPORT                              | 1   | 15 | BOSCH MOTOR 24V                            | 1   |
| 7  | CUTTING SYSTEM BIGGER STEM                  | 1   | 16 | MOTOR SUPPORT                              | 1   |
| 8  | TAP BOLT M8X30 ZINC PLATED STEEL PITCH 1,25 | 1   | 17 | END COURSE FM8108                          | 1   |
| 9  | TAP BOLT M4X16 ZINC PLATED STEEL PITCH 1,25 | 2   |    |  |     |

#### 14. ROUTER BOSCH 1,0 HP SUPPORT EXPLODED VIEW

| No | Description                                  | Qty |
|----|--|-----|
| 1  | PATIM H15                                    | 1   |
| 2  | CUTTING SYSTEM SPACER                        | 1   |
| 3  | HEX NUT M8 ZINC PLATED STEEL PITCH 1,25      | 2   |
| 4  | ROUTER LOCATOR SUPPORT                       | 1   |
| 5  | ROUTER SUPPORT LOCK                          | 1   |
| 6  | SHIM 2 MM SYSTEM CUTTING PATIN               | 1   |
| 7  | TAP BOLT M5X16 ZINC PLATED STEEL PITCH 0,8   | 4   |
| 8  | TAP BOLT M8X120 ZINC PLATED STEEL PITCH 1,25 | 2   |
| 9  | HEX NUT M5 ZINC                              | 6   |
| 10 | HEX NUT M8 ZINC                              | 2   |

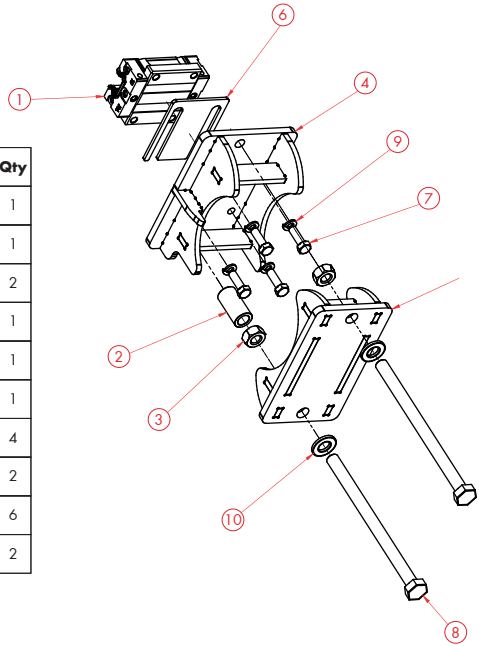

#### 15. ROUTER BOSCH 2,25 HP SUPPORT EXPLODED VIEW

| No | Description                                  | Qty |
|----|--|-----|
| 1  | CUTTING SYSTEM MOTOR SUPPORT                 | 1   |
| 2  | PATIM H15                                    | 1   |
| 3  | CUTTING SYSTEM SPACER                        | 1   |
| 4  | HEX NUT M8 ZINC PLATED STEEL PITCH 1,25      | 2   |
| 5  | SHIM 2 MM SYSTEM CUTTING PATIN               | 1   |
| 6  | ROUTER SUPPORT LOCK                          | 1   |
| 7  | TAP BOLT M8X120 ZINC PLATED STEEL PITCH 1,25 | 2   |
| 8  | TAP BOLT M5X16 ZINC PLATED STEEL PITCH 0,8   | 4   |
| 9  | HEX NUT M5 ZINC                              | 4   |
| 10 | HEX NUT M8 ZINC                              | 2   |

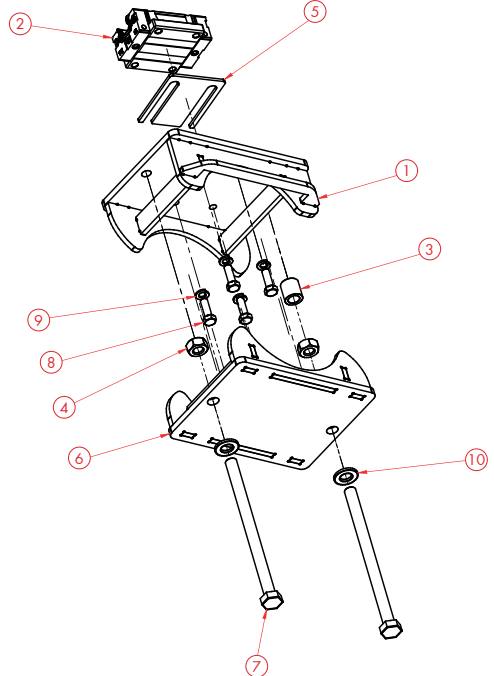



## 16. DEPH SCALE WITH KNOBS

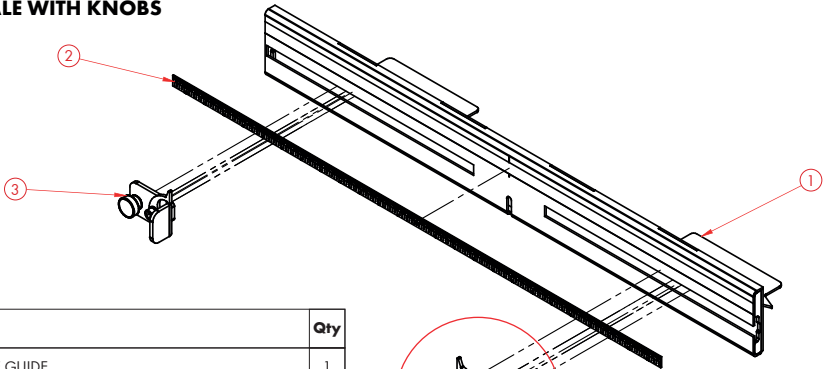

| No | Description                                | Qty |
|----|--|-----|
| 1  | TABLE MOBILE GUIDE                         | 1   |
| 2  | MILLIMETERS AND INCHES SCALE               | 1   |
| 3  | LEFT KNOB                                  | 1   |
| 4  | RIGHT KNOB                                 | 1   |
| 5  | STOP                                       | 1   |
| 6  | INDICATOR SPACER                           | 1   |
| 7  | NUT / SCALE                                | 1   |
| 8  | INDICATING POINTER                         | 1   |
| 9  | KNOB M6X16 PLATED STEEL PITCH 1,0          | 1   |
| 10 | HEX NUT M6 ZINC                            | 1   |
| 11 | TAP BOLT M6X16 ZINC PLATED STEEL PITCH 1,0 | 1   |

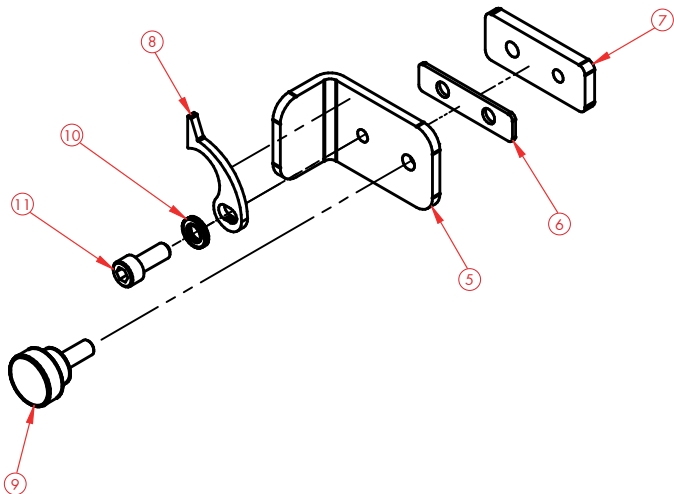



**Maksiwa International Inc.**

4100 N Powerline Rd, Suite D1

Pompano Beach, Florida - ZIP Code: 33073



**Contact us**

Tel: +1 (754) 205-6717 | Call us free: +1 (844) 319-6594

[customer.service@maksiwa.com](mailto:customer.service@maksiwa.com)

[maksiwa.com](https://maksiwa.com)

