

# SH-510LDMM

Semi-Automatic Linear Guided  
Double Miter-Cutting Horizontal Band saw



(Standard model)

## Instruction Manual

*The Pinnacle of Cutting Performance*  
Cosen Mechatronics Co., Ltd.



## FROM THE MANUFACTURER

Thank you for your purchase of COSEN's bandsaw machine and your trust in the COSEN brand.

We are excited to have you as our valued customer and look forward as much as you do to the accelerated productivity, long-lasting endurance and superb cost-effectiveness this machine is about to bring to you.

To ensure you are fully utilizing our machine and being advantaged in every possible way, please do take your time and read through this instruction manual.

Any comment or suggestion in making our service better, please do not hesitate to let us know. Thank you again!

### NOTE:



- Read this instruction manual carefully to familiarize yourself with the installation, operation and maintenance of your COSEN bandsaw machine.
- Operate the machine following the procedures described in the manual to prevent personal injuries or machine damage.
- Keep this manual handy and refer to it whenever you are uncertain of how to perform any of the procedures.



- For technical support or parts purchase, please contact your nearest COSEN representative or our service center:

For Europe:  
email: [europa@cosensaws.com](mailto:europa@cosensaws.com)  
phone: +31-77-7600280  
fax: +31-77-7600288  
web: [www.cosensaws.eu](http://www.cosensaws.eu)

For US, Mexico, and Canada:  
email: [info@cosensaws.com](mailto:info@cosensaws.com)  
phone: +1-704-943-1030  
toll free: +1-877-SAWING1  
fax: +1-704-943-1031  
web: [www.cosensaws.com](http://www.cosensaws.com)

For China:  
email: [service@cosensaws.cn](mailto:service@cosensaws.cn)  
phone: +86-152-50127815  
web: [www.cosensaws.cn](http://www.cosensaws.cn)

For Taiwan and other countries:  
email: [info@cosen.com](mailto:info@cosen.com)  
phone: +886-3-5332143  
fax: +886-3-5348324  
web: [www.cosen.com.tw](http://www.cosen.com.tw)

---

**Instruction Manual: SH-510LDM Semi-Automatic Linear Guided  
Double Miter-Cutting Horizontal Band saw (Standard model)**

Ver.1 2018/01/30

© 2018 by COSEN MECHATRONICS CO., LTD.

No part of this publication may be photocopied or otherwise reproduced without the prior written permission of COSEN.

Printed in Taiwan



# Safety rules



- Make sure your work area is cleared of uninvited people and obstacles every time before you start operating the machine.



- Never step or stand on the roller table. Your foot may slip or trip on the rollers and you will fall.



- Never wear gloves or loose clothing when operating the machine. It may lead to serious injury if they are caught in the running machine. Wrap or cover long hair.

- Never touch the running saw blade with gloves or not. It is dangerous if your hands, clothing or gloves are caught by the running blade.



- Make sure any use of fire is prohibited in the shop and install a fire extinguisher or other fire control device near the machine when cutting titanium, magnesium, or any other material that produces flammable chips. Never leave the machine unattended when cutting flammable materials.



- Use a water-soluble cutting fluid on this machine. Oil-based cutting fluids may emit smoke or catch fire, depending on how they are used.



- Never cut carbon or any other material that may produce and disperse explosive dust. It is possible that sparks from motors and other machine parts will ignite and explode the air-borne dust.

# Safety rules



- Never adjust the wire brush or remove chips while the saw blade is still running. It is extremely dangerous if hands or clothing are caught by the running blade.
- Stop the saw blade before you clean the machine. It is dangerous if hands or clothing are caught by the running blade.
- Never start the saw blade unless the workpiece has been clamped firmly. If the workpiece is not securely clamped, it will be forced out of the vise during cutting.



- Take preventive measures when cutting thin or short pieces from the work to keep them from falling. It is dangerous if the cut pieces fall.
- Use roller tables at the front and rear sides of the machine when cutting long work. It is dangerous if the work piece falls off the machine.



- Turn off the shop circuit breaker switch before performing maintenance on the machine. Post a sign indicating the machine is under maintenance.

# Table of Contents

<b>Section 1 – Safety Information</b>	<b>1-1</b>
Safety Instructions .....	1-1
Safeguard Devices .....	1-3
<i>Illustration: Safety Fence</i> .....	1-4
Emergency Stop .....	1-5
<i>Illustration: Emergency Stop</i> .....	1-6
Safety Labels .....	1-7
<i>Illustration: Safety Labels</i> .....	1-8
Hearing Protection .....	1-9
CE Compliance .....	1-9
Risk Assessment .....	1-9
<b>Section 2 – General Information</b>	<b>2-1</b>
Specification .....	2-2
Machine Parts Identification .....	2-3
Floor Plan .....	2-5
<b>Section 3 – Moving &amp; Installation</b>	<b>3-1</b>
Location & Environment .....	3-1
Unpacking & Inspecting .....	3-2
Lifting .....	3-3
<i>Illustration: Lifting Points</i> .....	3-5
Removing Shipping Bracket .....	3-6
Cleaning .....	3-6
Installing .....	3-6
Supplying Hydraulic Oil .....	3-6
Supplying Coolant .....	3-7
Connecting Electric Power .....	3-7
Leveling & Anchoring .....	3-8
Installing Roller Table (Optional) .....	3-9
Installing Fire Control Device .....	3-9
Relocating .....	3-9
<b>Section 4 – Operating Instructions</b>	<b>4-1</b>
Safety Precautions .....	4-2
Before Operating .....	4-3
Control Panel .....	4-4
Control Panel .....	4-4

# Table of Contents

Control Buttons .....	4-5
Blade Descend Pressure & Speed .....	4-7
HMI Touch Screen & Functions .....	4-7
HMI Error Codes .....	4-17
Standard Accessories .....	4-18
Optional Accessories .....	4-20
Unrolling & Installing the Blade .....	4-21
Adjusting Wire Brush .....	4-23
Placing Workpiece onto Workbed .....	4-23
Positioning Workpiece for Cutting .....	4-24
Adjusting Saw Arm.....	4-25
Adjusting Coolant Flow .....	4-25
Adjusting Blade Speed .....	4-26
Breaking-In the Blade .....	4-26
Test -Running the Machine .....	4-26
Cutting Operation .....	4-27
Starting an Automatic Cutting.....	4-28
Using Top Clamp for Bundle Cutting.....	4-28
Terminating a Cutting Operation .....	4-29
<b>Section 5 – Electrical System</b> .....	<b>5-1</b>
Electrical Circuit Diagrams .....	5-1
<b>Section 6 – Hydraulic System</b> .....	<b>6-1</b>
Hydraulic Diagrams .....	6-1
<b>Section 7 – Bandsaw Cutting: A Practical Guide</b> .....	<b>7-1</b>
Introduction .....	7-1
Saw Blade Selection .....	7-2
<b>WISE LOADING</b> .....	<b>7-3</b>
<b>BladeBreak -In</b> .....	<b>7-4</b>
<b>Section 8 – Maintenance &amp; Service</b> .....	<b>8-1</b>
Introduction .....	8-1
Basic Maintenance .....	8-1
Maintenance Schedule .....	8-2
Before Beginning a Day’s Work .....	8-2
After Ending a Day’s Work .....	8-2
<b>Every 2 weeks</b> .....	<b>8-2</b>
<b>First 600hrs for new machine,then every 1200h</b> .....	<b>8-2</b>



# Table of Contents

Every Six Months .....	8-3
Storage Conditions .....	8-3
Terminating the Use of Machine .....	8-3
Oil Recommendation for Maintenance .....	8-4
<b>Section 9 – Troubleshooting</b>	<b>9-1</b>
Introduction .....	9-1
Precautions .....	9-2
General Troubles & Solutions .....	9-2
Minor Troubles & Solutions .....	9-3
Motor Troubles & Solutions .....	9-3
Blade Troubles & Solutions .....	9-4
Sawing Problems & Solutions .....	9-5
Re-Adjusting the Roller Table .....	9-12
<b>Section 10 – Parts</b>	<b>10-1</b>
Spare Parts Recommendations .....	10-1
Part List .....	10-2
<b>Section 11 – Warranty</b>	<b>11-1</b>
Warranty.....	11-1



# SAFETY INFORMATION

## SAFETY INSTRUCTIONS

## SAFEGUARD DEVICES

## EMERGENCY STOP

## SAFETY LABELS

## HEARING PROTECTION

## CE COMPLIANCE

## RISK ASSESSMENT

Safety is a combination of a well-designed machine, operator's knowledge about the machine and alertness at all times. COSEN's band machine has incorporated many safety measures during the design process and used protective devices to prevent personal injuries and potential risks. Warning labels also serve as a reminder to the operator.

Throughout this manual, you will also see various safety-related symbols indicating important information that you should take note of prior to use of the machine or part of its functions. These important safety instructions do not cover all possible situations that might occur. It is your responsibility to take caution and follow procedures stated in this manual when installing, maintaining and operating your machine. Cosen will not be liable for damages resulting from improper use.

## SAFETY INSTRUCTIONS

What the icons and signs in this user manual mean:



This icon marks **WARNING**; hazards or unsafe practices that may result in **personal injury or damage to the machine**.



Supplementary information to the procedures described in this manual.



Call your local agent or our service center for help.



This manual has important safety information. Read through it carefully before operating this machine to prevent personal injury or machine damage. Learn the operation, limitation and the specific potential hazards peculiar to this band saw. All users must read it before performing any activity on the machine, such as replacing the saw band or doing regular maintenance.



Disconnect the power cord before making adjustment, maintenance or blade changes.



Do not operate this machine unless it is completely assembled.



Make sure the power switch is off before plugging in power cord.



Always remember to switch off the machine when the work is completed.



Use recommended accessories. Improper accessories may be hazardous.



Never hold the material by hand for cutting. Always use the vise and make sure the material is clamped securely before cutting.



When a workpiece is too long or heavy, make sure it is supported with a roller table (recommended).



Keep your work area well illuminated at minimum 500 lumen.



Remove adjusting keys, wrenches or any loose parts or items from the machine before turning on power.



Use a sharp saw blade and keep the machine in its best and safest performance by following a periodical maintenance schedule.



Wear proper apparel during operation and when servicing the machine. Some personal protective equipment is required for the safe use of the machine, e.g. protection goggles.



Moving parts should be kept in proper alignment and connection with the machine. Check for breakage, mounting and any other conditions that may affect its operation. Any damaged part or guard should be properly repaired or replaced.



It is dangerous to operate the machine when the floor is slippery. Keep the floor clean and dry. Check for ice, moisture, or grease before entering.



Do not use the machine to cut explosive material or high pressure vessels as it will generate great amount of heat during the sawing process and may ignite an explosion.



Keep your work area clean. Cluttered and slippery floors invite accidents.



Keep blade protection cover and wheel covers in place and in working order.



Never operate while under the influence of drugs, alcohol or medication.



Do not reach over or stand on any part of the machine.



Keep the work environment safe. Do not use band saw in a damp or wet location.



Keep all guards and shields in place before installing or starting up the machine.



Keep unauthorized personnel away.

## SAFEGUARD DEVICES

The safeguard devices incorporated in this machine include the following two main parts:

1. Protection covers & guards
2. Safety-related switches

### Protection Covers & Guards

1. Idle wheel housing cover
2. Drive wheel housing cover
3. Gear reducer cover
4. Wire brush belt cover
5. Blade guard cover (left & right)
6. Safety fence (left & right)(CE model only, as shown in Illustration: *Safety Fence*)
7. Chip conveyor cover (CE model only)



The protection devices should always be mounted on the machine whenever the machine is running.



Do not remove any of these safeguard devices under any circumstances except when servicing the machine. Even skilled service technicians should still take cautions when performing repairs or service on the machine with any of these protectors removed. It is the responsibility of the user to make sure all these elements are not lost and damaged.



Take note of the following main moving parts on the machine prior to and during machine operation:

- Saw bow assembly
- Drive and idle wheels
- Blade guide arm
- Saw blade guide rollers
- Quick approach device (optional)
- Wire brush
- Chip conveyor (optional)
- Workpiece clamping vises
- Shuttle vises and workbed rollers
- Top clamps (optional)
- Gear reducer

## **Safety Related Switches**

To protect the operator, the following safety related switches on the machine are actuated when the machine is in operation.

Wheel motion detector	This is a proximity sensor used to detect the motion of the drive wheel. Once the saw blade is broken or as soon as it starts slipping, the sensor will detect and stop the drive wheel and the machine.
Power switch	Located on the cover of electrical cabinet, the power switch controls the main power of the machine. Up to your company's internal rules, this power switch can be locked with a padlock or a luggage lock to protect the operator and the machine.
Emergency stop button	Located on the control panel, the button when pressed will stop the machine completely.
Vise clamp switch	This switch assures firm clamping of the workpiece. If the workpiece is not clamped properly, the saw blade is not allowed to run.
Wheel cover interlock switches (CE model only)	Located on the two wheel housings, these switches are used to assure that the machine will stop whenever the wheel covers are open. This device is to protect users from being cut by the running saw blades.

Among all these safety switches, some of them are used to protect the users and some of them are used to prevent damage to saw blades, the workpiece and the machine itself, etc. We have taken every precaution to prevent injury or damage and to provide safe and economical operation of the machine.

## **EMERGENCY STOP**

Designed to be easily accessible, the emergency stop button is located on the left bottom corner on the control panel and is made in red color and rubber material. For CE models, supplementary emergency stop button may be available at other area(s) of the machine depending on machine type. Please refer to *Illustration: Emergency Stop*.

When you press the button, the machine will immediately come to a full stop to avoid injury or damage when an accident occurs. The button will be locked when you press it. To unlock it, turn the button clockwise.

You should press it immediately without any hesitation when observing:

- An emergency situation that would cause any injury or damage
- An abnormal situation or problem such as fire, smoke, abnormal noise and etc.

## **Safety Related Switches**

To protect the operator, the following safety related switches on the machine are actuated when the machine is in operation.

Wheel motion detector	This is a proximity sensor used to detect the motion of the drive wheel. Once the saw blade is broken <b>or as soon as it starts slipping</b> , the sensor will detect and stop the drive wheel and the machine.
Power switch	Located on the cover of electrical cabinet, the power switch controls the main power of the machine. <b>Up to your company's internal rules, this power switch can be locked with a padlock or a luggage lock to protect the operator and the machine.</b>
Emergency stop button	Located on <b>the control panel</b> , the button when pressed will stop the machine completely.
Vise clamp switch	This switch assures firm clamping of the workpiece. If the workpiece is not clamped properly, the saw blade is not allowed to run.
<b>Wheel cover interlock switches (CE model only)</b>	<b>Located on the two wheel housings, these switches are used to assure that the machine will stop whenever the wheel covers are open. This device is to protect users from being cut by the running saw blades.</b>

Among all these safety switches, some of them are used to protect the users and some of them are used to prevent damage to saw blades, the workpiece and the machine itself, etc. We have taken every precaution to prevent injury or damage and to provide safe and economical operation of the machine.

## **EMERGENCY STOP**

Designed to be easily accessible, the emergency stop button is located on the left bottom corner on the control panel and is made in red color and rubber material. **For CE models, supplementary emergency stop button may be available at other area(s) of the machine depending on machine type. Please refer to *Illustration: Emergency Stop*.**

When you press the button, the machine will immediately come to a full stop to avoid injury or damage when an accident occurs. The button will be locked when you press it. To unlock it, pull it upward.

You should press it immediately without any hesitation when observing:

- An emergency situation that would cause any injury or damage
- An abnormal situation or problem such as fire, smoke, abnormal noise and etc.

**Illustration: Emergency Stop**

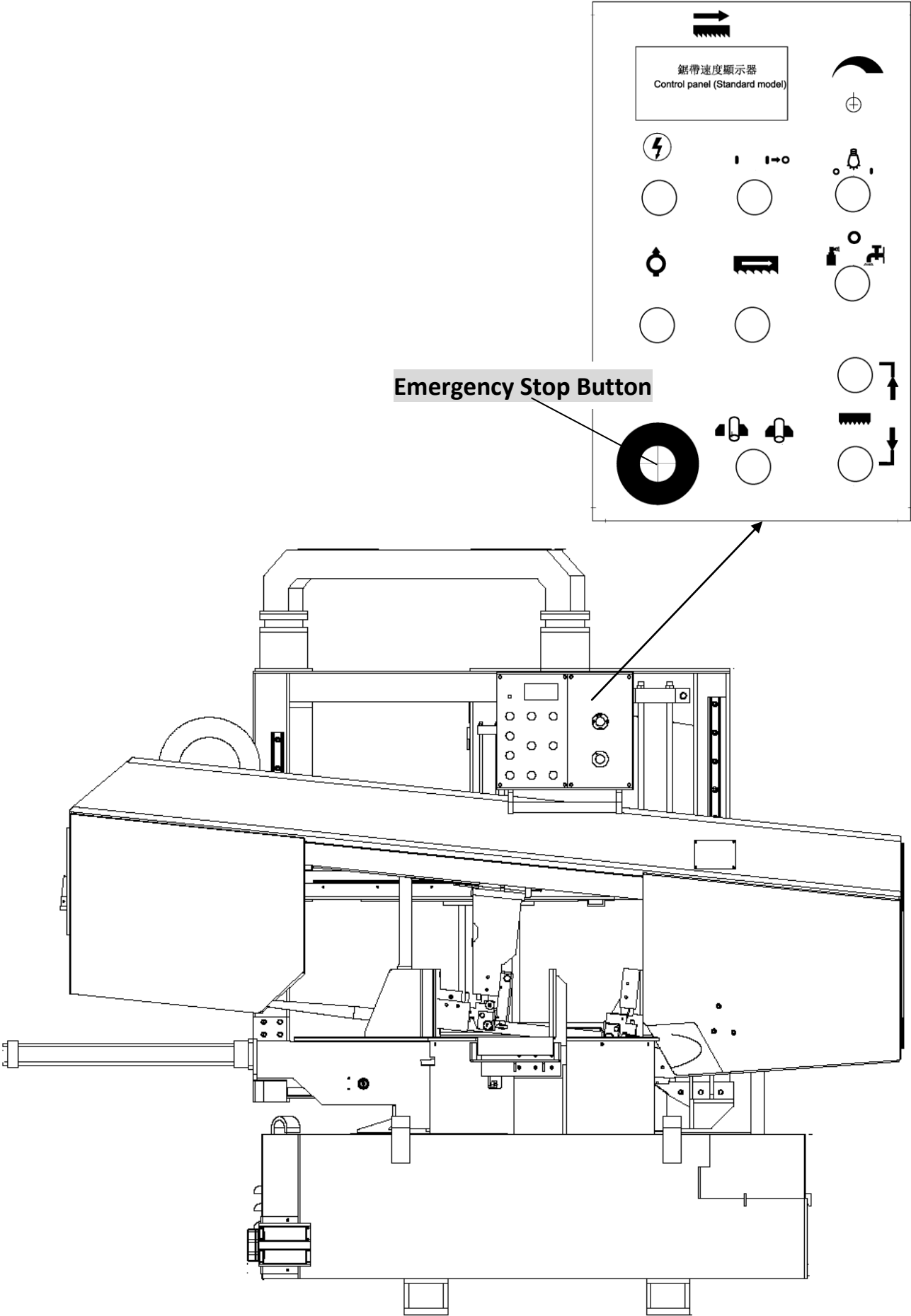



## SAFETY LABELS

Please read through and understand these safety labels before operating the machine. Refer to *Illustration: Safety Labels*.

Label	Meaning	Label	Meaning
	Impact Hazard  WEAR SAFETY SHOES. Do not approach dropping area during operation.		Read Operator's Manual  This manual has important safety information. Read through it carefully before operating this machine to prevent personal injury or machine damage.
	Keep Unauthorized Personnel Away		Do not step.  Do not stand on the machine or on the accessories!
	DANGER: Running Blade  Blade runs through this area. Keep your hands away from a running blade to avoid severe injury. The arrow indicates direction of the blade.		Cutting Hazard  KEEP COVER CLOSED / KEEP HAND OFF while the blade is running. Turn power off before opening cover. Failure to follow the warning can result in severe injury.
	Hazardous Voltage  TURN POWER OFF before servicing. Failure to following the warning can result in severe injury.		Burn Hazard/Hot Surface
	Hand Crush/Force from Above		Crush hazard by vise
	Loose Hand Hazard  KEEP HAND OFF. Do not touch chip conveyor. Failure to follow the warning can result in severe injury.		Pinch Point/Hand Entanglement

**Illustration: Safety Labels**

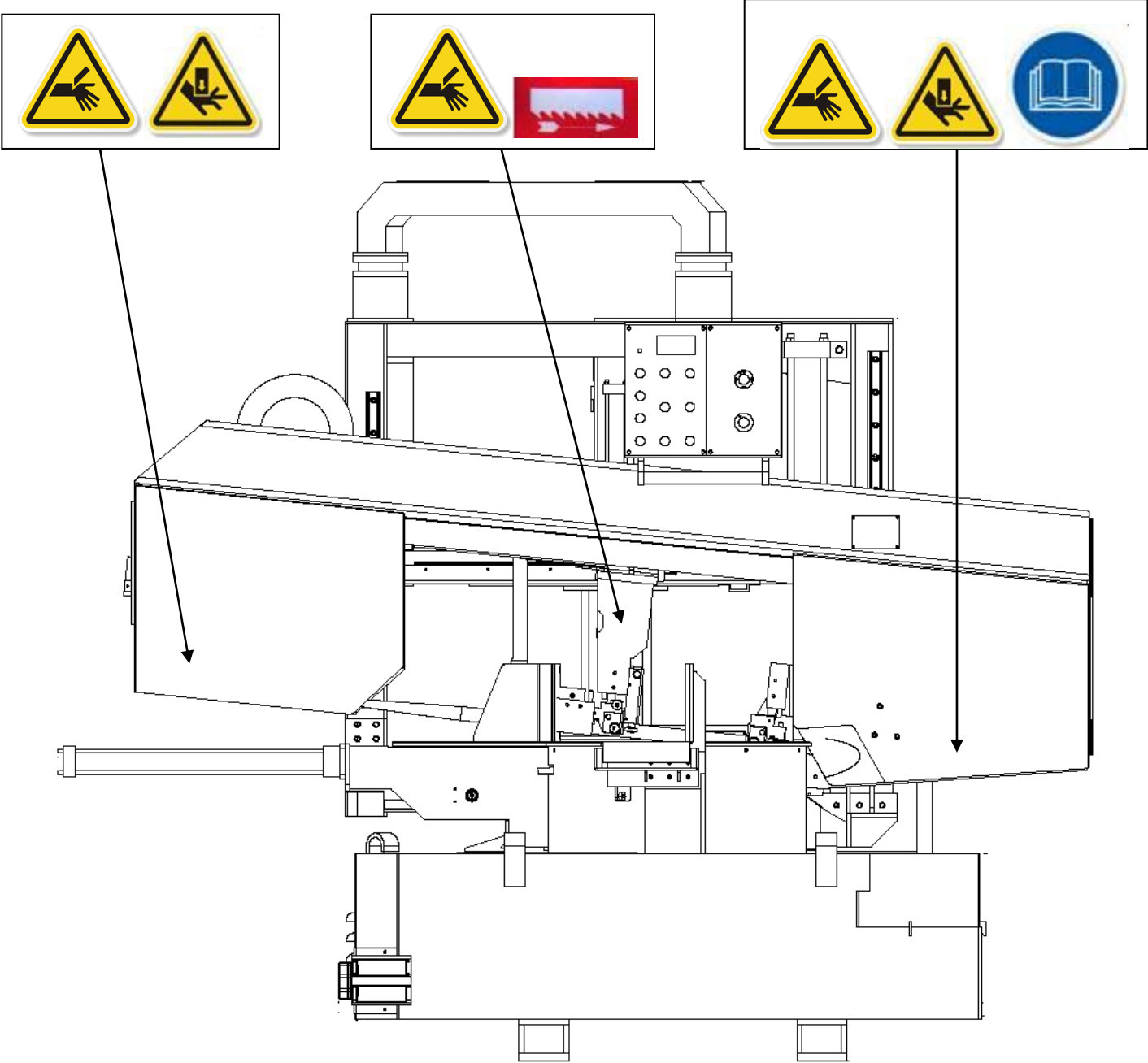

## HEARING PROTECTION



Always use ear protection!

When your machine is running, noise generated by the machine may come from the following:

- Saw blade during cutting or material feed mechanism
- Wire brush unit
- Chip conveyor unit
- Speed reducer
- Hydraulic motor/pump
- Belt transmissions variable speed motors
- Blade motor
- Coolant pump
- Drive wheel
- Parts not assembled tightly causing mechanical vibration

Our products pass noise testing less than 78 dBA. Noise level vary according to working conditions and we recommend ear plugs or other hearing protection at all time. If your machine produces an undesirable noise while it is running, you should:

1. Make sure all maintenance tasks have been performed following the prescribed maintenance schedule (Refer to Section 8).
2. If maintenance does not seem to solve the problem, follow the troubleshooting procedures under Section 9.

## CE COMPLIANCE

**Cosen's** CE model is designed to satisfy regulations of the Council Directive on the approximation of the laws of the Member States relating to machinery ([2006/42/EC](#)) - Annex I Essential health and safety requirements relating to the design and construction of machinery.

## RISK ASSESSMENT

Risk assessment generally takes account of intended use and foreseeable misuse, including process control and maintenance requirements. We made every effort to avoid any personal injury or equipment damage during the machine design stage. However, the operator (or other people) still needs to take precautions when handling any part of the machine that is unfamiliar and anywhere on the machine that has potential hazards (e.g. the electrical control box).



# *GENERAL INFORMATION*

## **SPECIFICATION**

## **MACHINE PARTS IDENTIFICATION**

## **FLOOR PLAN**

This band saw machine is designed by Cosen's R&D engineers to provide you the following features and advantages:

### Safety

- This machine is designed to fully protect the operator from its moving parts during cutting operation.
- The machine and each component has passed strict testing (Council Directive on the approximation of the laws of the Member States relating to Machinery).
- The machine will shut off automatically when the saw blade is broken, protecting both the operator and the machine.

### Convenience & High-Performance

- The machine is designed in the way that the operation and adjustment can be easily performed.
- The machine will stop automatically when out of stock.
- Dual valve system is designed to achieve optimal cutting performance with the simple setting of feed rate and perspective cutting pressure for different material.

### Durability

- The intended life-span of the machine is counted based on regular daily operation. It is calculated with the life expectancy of 10 years under normal operating condition and exact attention to the maintenance schedule.

8 hours × 5 days × 52 weeks × 10 years = 20,800 hours

## SPECIFICATION

Model		<b>SH-510LDMM</b> Semi-Automatic Linear Guided Double Miter-Cutting Horizontal Band saw		
Capacity	Miter Angle	0°	±45°	±60°
	Round	320 mm (12.5")	320 mm (12.5")	200 mm (7.8")
	Rectangular (H x W)	330 x 510 mm (12.9" x 20")	330 x 320 mm (12.9" x 12.5")	330 x 200 mm (12.9" x 7.8")
	Bundle	W: 0~510mm (0~20") H: 0~330mm (0~12.9")		
Saw Blade	Speed	25~120 m/min (83 ~ 393.7 fpm)		
	Size (L x W x T)	4980 x 34 x 1.1 mm (196" x 1.33" x 0.04")		
	Tension	Hydraulic with automatic blade breakage detection		
	Guide	Interchangeable tungsten carbide		
	Cleaning	Steel wire brush with flexible drive shaft driven by main motor		
Motor Output	Saw Blade	3 HP (2.2kW)		
	Hydraulic	1 HP (0.75 kW)		
	Coolant Pump	1/8 HP (0.1 kW)		
Tank Capacity	Hydraulic	32.5 L		
	Coolant	60 L		
Workbed Height		780 mm (30.7")		
Gross Weight		2,900 kgs (6,380 lbs)		
Floor Space (L x W x H)		2562 x 2617 x 2143 mm (101" x 103" x 84.4")		
Packing Size (L x W x H)		2500 x 1260 x 2100 mm (98.4" x 49.6" x 82.6") (No pallets)		
Operating Environment	Temperature	5~40°C (41~104°F)		
	Humidity	30%~85% (without condensation)		

# MACHINE PARTS IDENTIFICATION

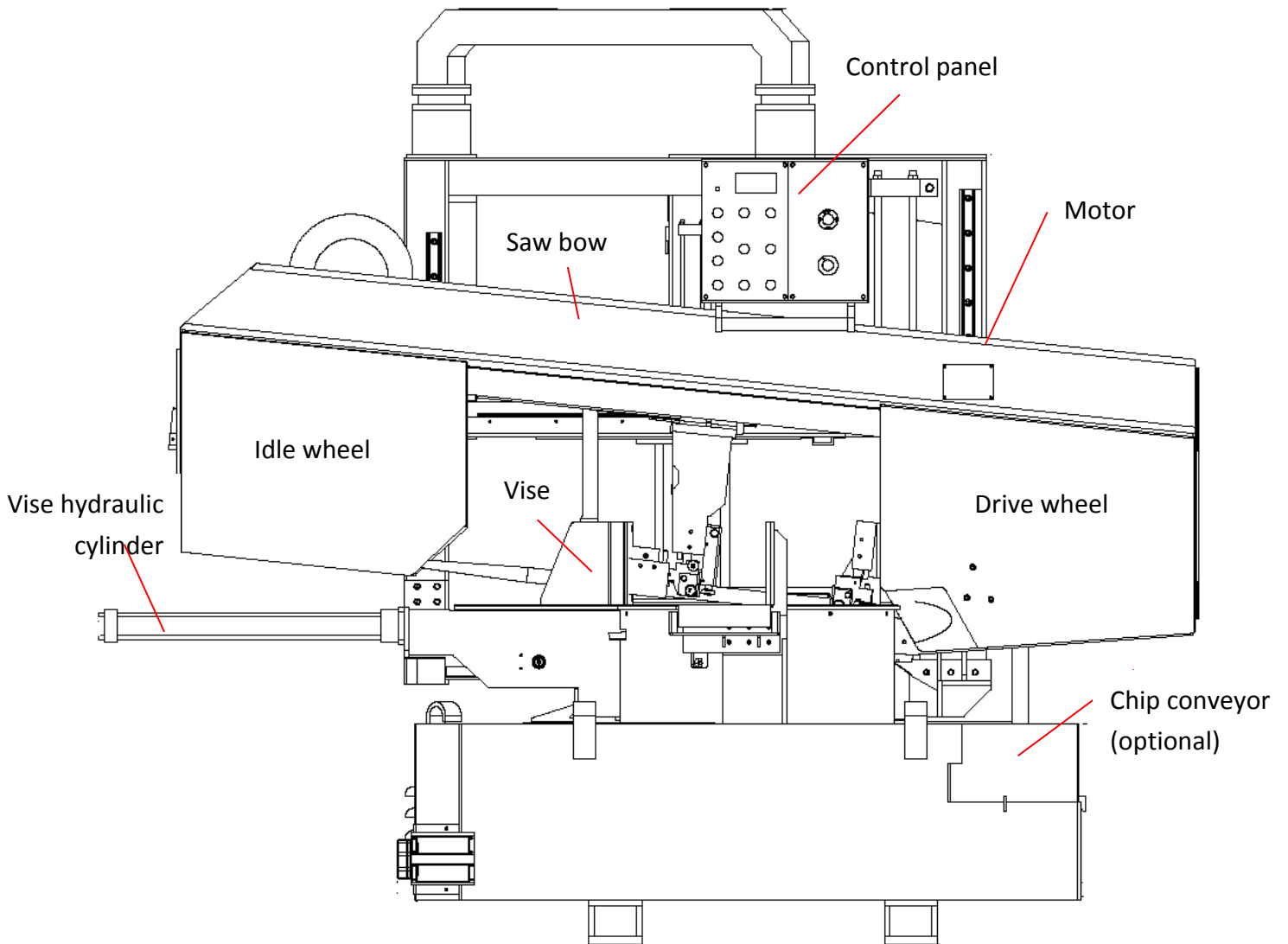

**FLOOR PLAN**

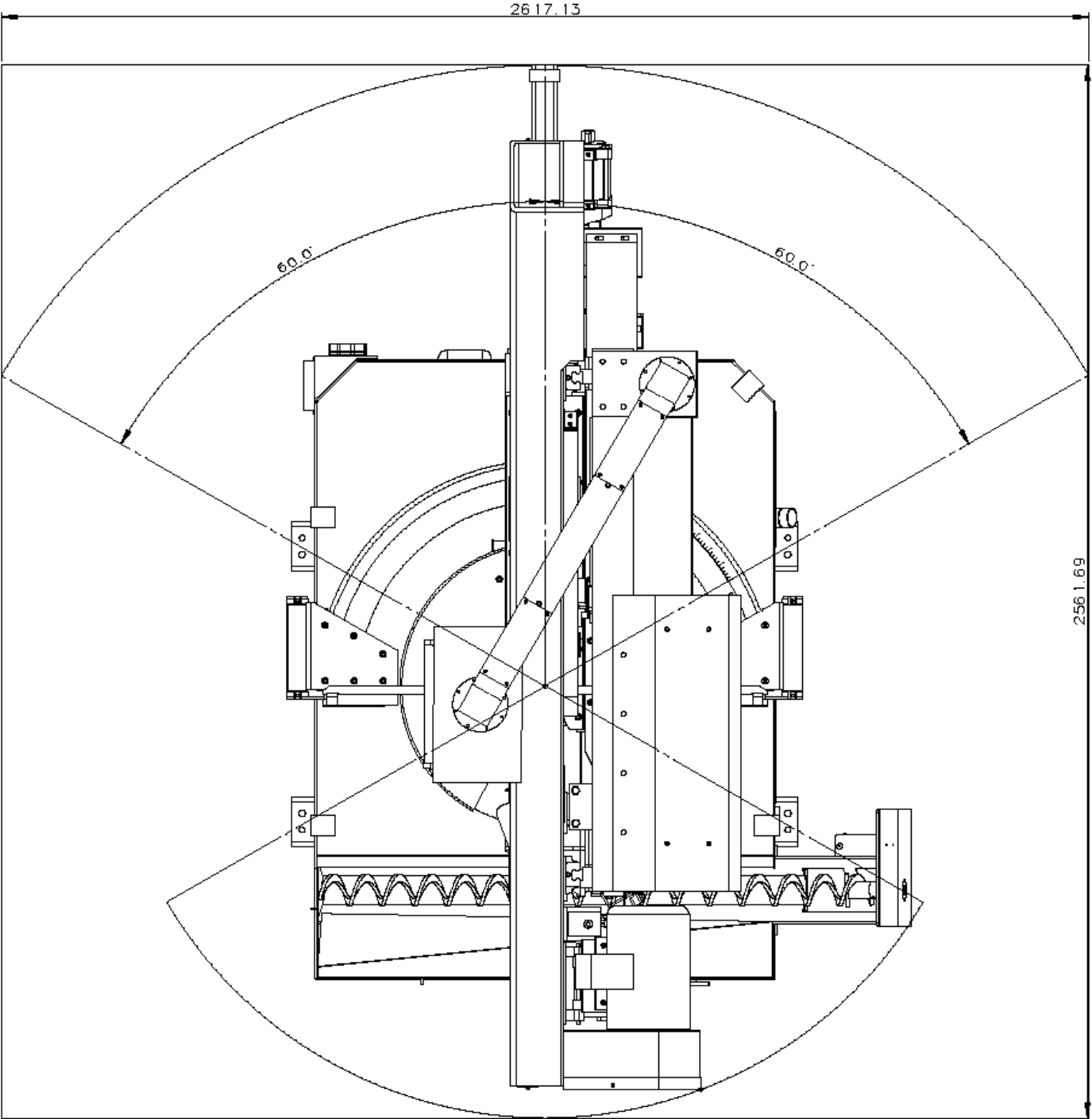

**Machine top view**



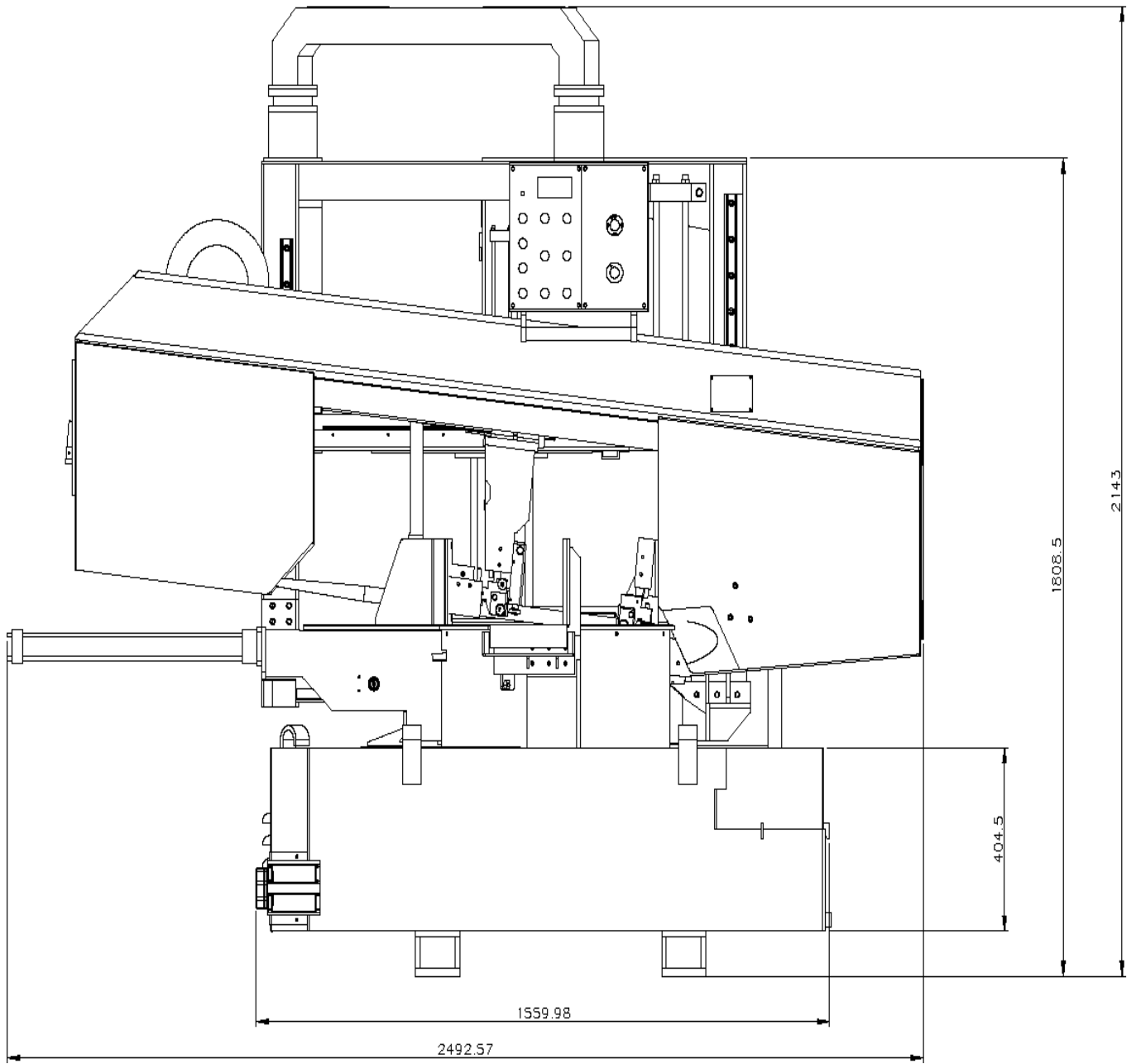

**Machine front view**

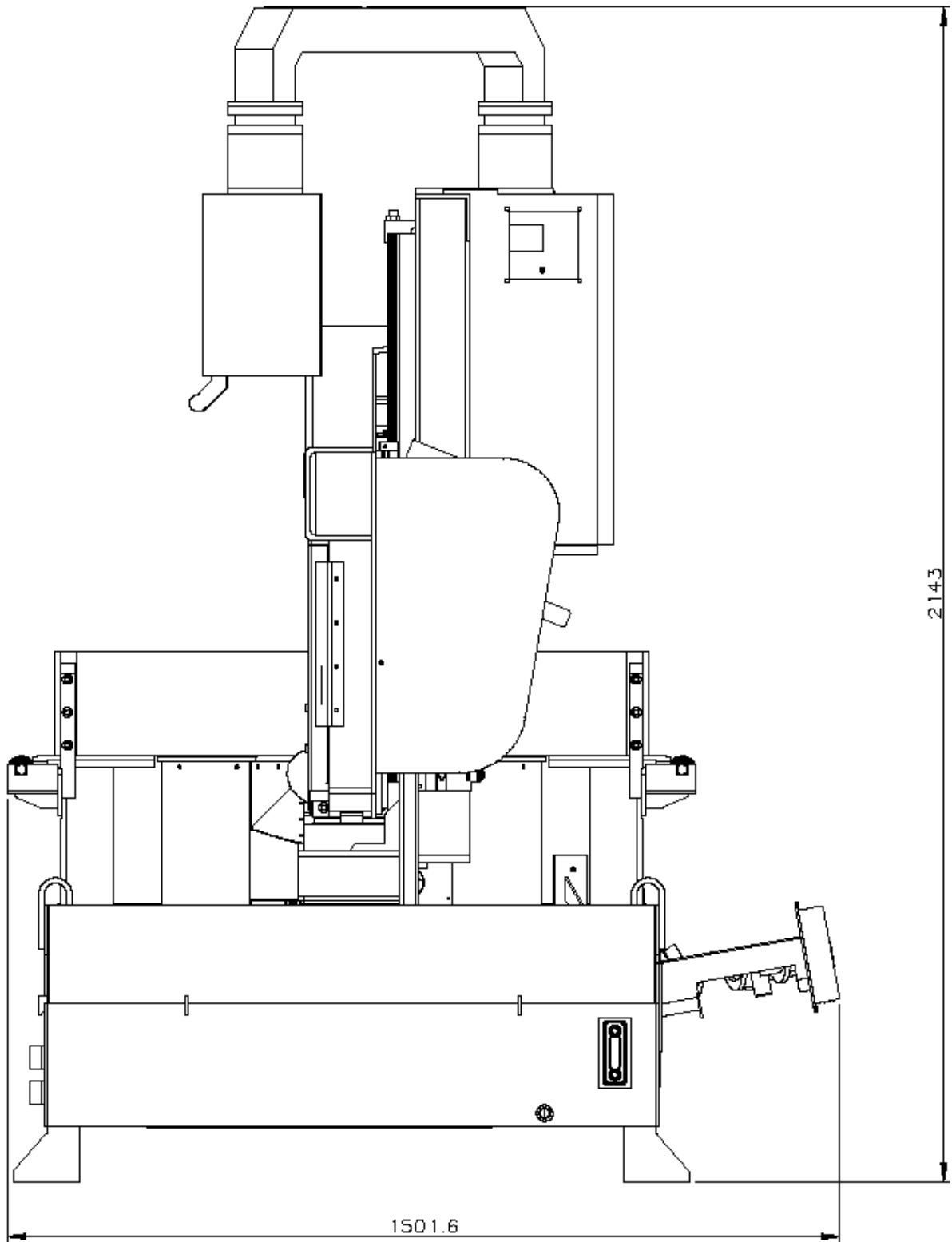

Machine side view

# MOVING & INSTALLATION

LOCATION & ENVIRONMENT

UNPACKING & INSPECTING

LIFTING

REMOVING SHIPPING BRACKET

CLEANING

INSTALLING

RELOCATING

## LOCATION & ENVIRONMENT

For your safety, please read all information regarding installation before proceeding. Install your machine in a place satisfying all of the following conditions:

### Space:

- Leave enough free space around the machine for loading work and unloading cut-off pieces as well as for maintenance and inspection. Refer to *Section 2 General Information - Specification* for machine dimensions and floor space.

### Environment:

- Well lighted (500 lumen at minimum).
- Floor kept dry at all times in order to prevent operators from slipping.
- Away from direct exposure to the sunlight
- Room temperature between 5°C to 40°C.
- Humidity level kept at 30%~95%“(without condensation) to avoid dew on electric installation and machine.
- Away from vibration of other machines
- Away from powders or dusts emitted from other machines
- Avoid uneven ground. Choose a solid level concrete floor which can sustain weight of both machine and material.
- Limit the operation area of the machine to staff only.



## UNPACKING & INSPECTING

- Unpack your machine carefully to avoid damage to machine parts or surfaces.
- Upon arrival of your new band saw, please confirm that your machine is the correct model and it comes in the same specification you ordered by checking the model plate on the machine base.
- It is also imperative that a thorough inspection be undertaken to check for any damage that could have occurred during shipping. Pay special attention to machine surface, equipments furnished and the electrical and hydraulic systems for damaged cords, hoses and fluid leaks.
- In the event of damage caused during shipping, please contact your dealer and consult about filing a damage claim with the carrier.
- Your machine comes in with a set of tools for you to maintain the machine. The accessories furnished are as follows:
  1. Tool box 1 pc
  2. Grease gun 1 pc
  3. Screwdriver (+, -) 2 pcs
  4. Open-ended spanner 3 pcs
  5. Hexagon wrench 1 set
  6. Chip spade (only for manual models) 1 pc
  7. Operation manual 1 pc



Should you find any missing accessories, please contact your local agent immediately.

## LIFTING

When moving the machine, we strongly suggest you choose any one of the methods described below to move your machine.



1. **Use a crane (Only applies to the machine with the design of the hanging point.)**

Move the machine to its location by using a crane and a wire rope sling that can fully withstand the weight of the machine (refer to machine specification under Section 2 *General Information*).



Machine hanging with a crane should be done strictly according to the hanging points designated by the original manufacturer. If there is any doubt on missing hanging points on your machine, please consult with the original manufacturer or its qualified agent before hanging the machine.

- Machine lifting is likely to damage the machine if not performed properly.



You must have a qualified crane operator to perform the job.



- You must use tools and equipment with the proper tensile strength and use proper method when moving your machine.

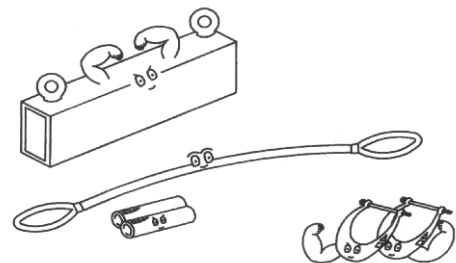

- Apply the wire rope sling to the lifting hooks on the four ends of the machine. Refer to *Illustration: Lifting Points* for exact locations.

- Slowly lift the machine. Be sure to protect the machine from impact or shock during this procedure. Also watch out your own fingers and feet to avoid injuries.

- Keep the machine well balanced during lifting process and make sure the wire rope does not interfere with the saw frame.

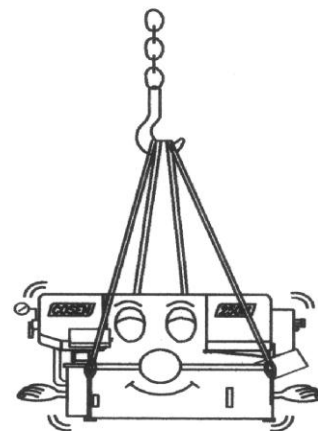

- When you work together with more than two people, it is best to keep constant verbal communication with each other.

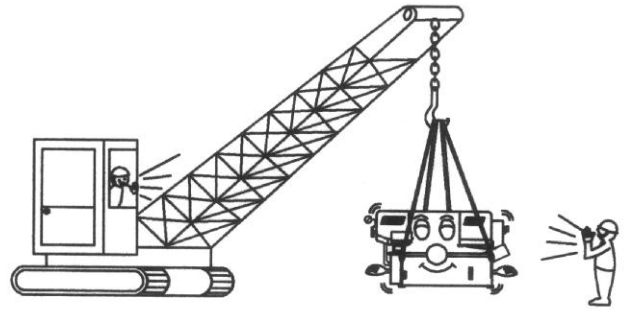

2. **Use a forklift (Only applies to the machine with the design of the lifting point.)**

Make sure that the lifting rod can fully withstand the weight of the machine. (Refer to *Section 2 – General Information for Specifications.*)



Machine lifting with a forklift should be done strictly according to the lifting points designated by the original manufacturer. If there is any doubt on missing lifting points on your machine, please consult with the original manufacturer or its qualified agent before lifting the machine.

- Machine lifting is likely to damage the machine if not performed properly.



You must have a qualified forklift operator to perform the job.



- You must apply proper forklift technique to avoid damage to the machine.



Make sure the forks are able to reach in at least 2/3 of the machine depth.

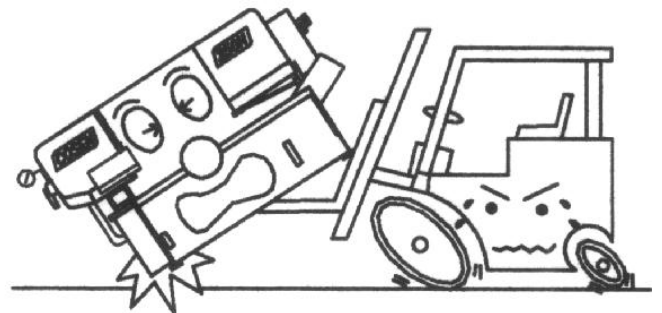

- You must keep the machine balanced at all times.



Make sure the forks are centered before use.

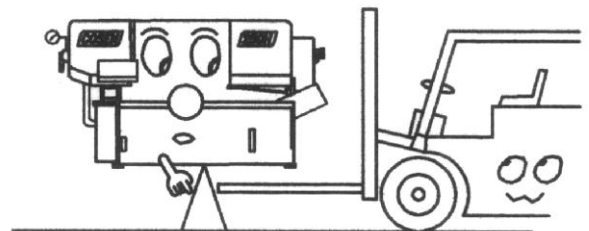

(Illustration only.)

- You must use rolling cylinders made in material of proper compressive strength.

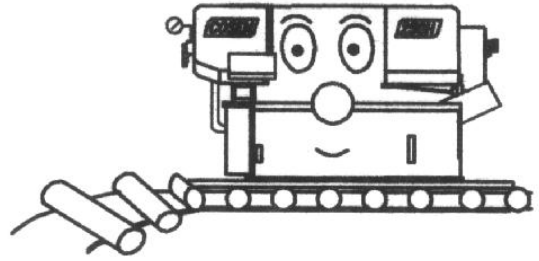

#### 4. Other ways to move

If the machine does not have



or



stickers, please contact your local agent immediately.

#### *Illustration: Lifting Points*

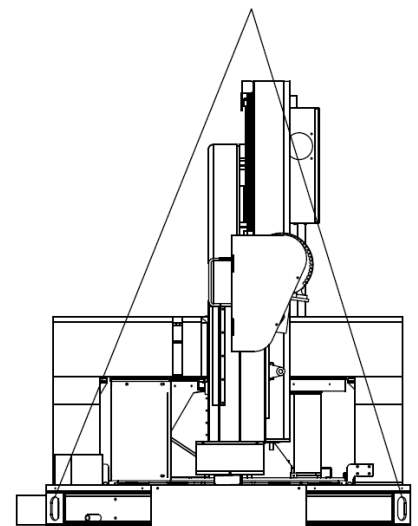
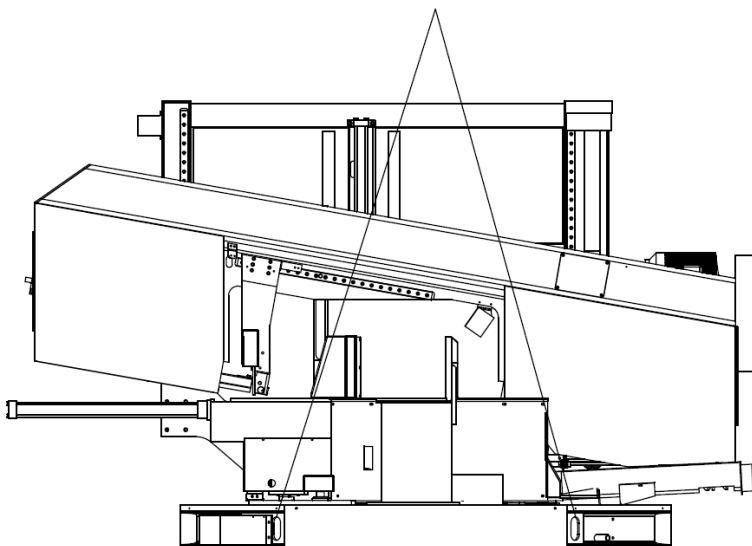
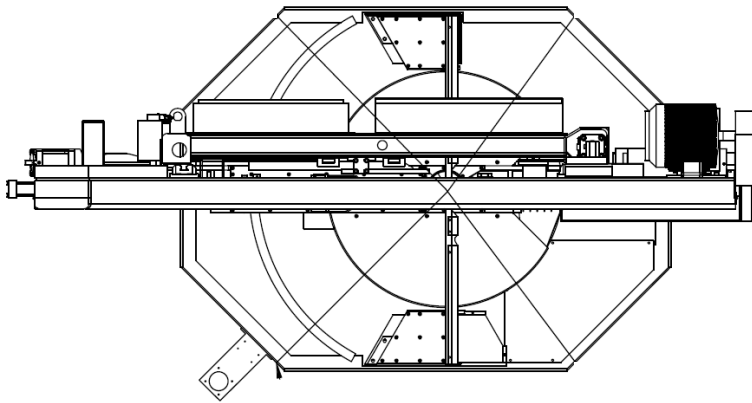

Minimum weight capacity for each wire rope: **3 ton**

Total number of wire ropes required: **4**

## REMOVING SHIPPING BRACKET

- After the machine has been properly positioned, remove the shipping bracket that is used to lock the saw frame and the saw bed.
- Retain this bracket so that it can be used again in the event that your machine must be relocated.

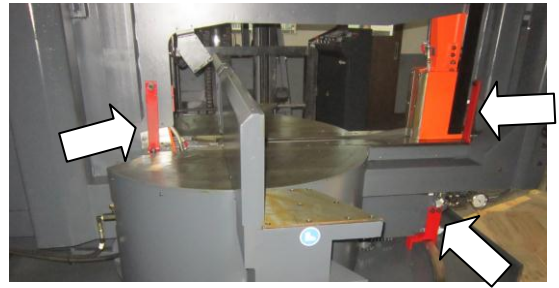

## CLEANING

After the machine has been placed at the designated position, remove the rust-preventive grease with wiping cloth dampened with cleaning oil or kerosene. Apply machine oil to machine surfaces that are prone to rust.



Do not remove the rust-preventive grease with a metal scraper and do not wipe the painted surfaces with solvent as doing so would damage surface paint.

## INSTALLING

Cosen's bandsaw machine is relatively easy to install. Follow these six easy steps to install your machine.

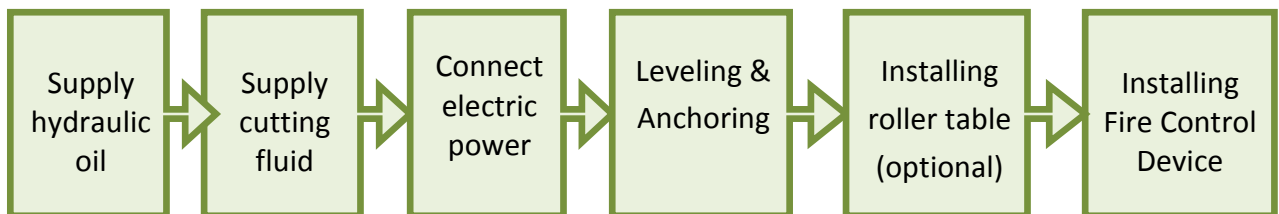

### Supplying hydraulic oil

Open the filler cap and fill the hydraulic oil tank to above 2/3 or full level.

Check the sight gauge to make sure the oil level in the tank.



Refer to specification chart under Section 2 for tank capacity.



## Supplying coolant

Fill the coolant tank to the middle level of the sight gauge by pouring the coolant from above the chip conveyor.

Use the sight gauge to check the coolant level remaining in the tank.



Always check the coolant supply before starting the machine. If the coolant pump is started without enough coolant supply in the tank, the pump and its drive motor may be damaged.



Refer to specification chart under Section 2 *General Information* for tank capacity.



Consult your coolant supplier for bandsaw use regarding coolant type and mix ratio.

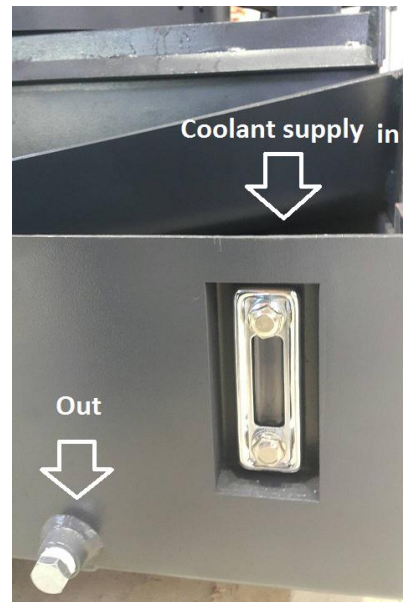

## Connecting electric power



Have a qualified electrician make the electrical connections.



If the power supply voltage is different from the transformer and motor connection voltage shown on the label attached to the electrical compartment of the machine, contact COSEN or your agent immediately.



Connect to power supply independently and directly. Avoid using the same power supply with electric spark machines such as electric welder. Unstable electric tension may affect your machine's electric installation from working properly.



Ground the machine with an independent grounding conductor.



Supply voltage: 90% - 110 % of nominal supply voltage.



Source frequency: 99% - 101 % of nominal frequency.



Refer to the specification chart under Section 2 for total electric power consumption of the motors and make sure your shop circuit breaker is capable of this consumption amount. Also use a power supply cable of proper size to suit the power supply voltage.

1. Turn off the shop circuit breaker.
2. Make sure the machine circuit breaker switch on the electrical compartment door is turned to OFF.
3. Remove the screw securing the electrical compartment and then open the door.
4. Pull the power supply cable and grounding conductor through the power supply inlet into the electrical compartment. (Shown right)
5. Connect the power supply cable to the circuit breaker (N.F.B.) to the R, S and T terminals, and connect the ground cable to the E terminal.
6. Close the compartment door and fasten the screw back.
7. Turn on the shop circuit breaker and then turn the machine circuit breaker switch to ON. The *Power Indicator* on the control panel will come on.
8. Turn clockwise to unlock the *Emergency Stop* button and press the *hydraulic ON* button to start the hydraulic motor.
9. Make sure the sawing area is clear of any objects. Start the blade and check the blade rotation. If the electrical connections are made correctly, the blade should run in a counterclockwise direction. If not, shut the hydraulics off, turn off the machine as well as the shop circuit breaker. Then swap the power the power cable conductors connected to R and T terminals.
10. Repeat step 6 to 9 to ensure the electrical connections are in the right order.



## **Leveling**

Place spirit level on the vise slide plates and the work feed table.

Level the machine in both directions i.e. along and across the machine. Adjust the level of the machine by turning the leveling bolts.

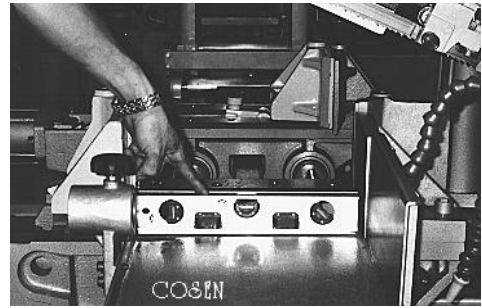

Make sure all leveling bolts evenly support the machine weight.

## **Anchoring**

Normally there is no need to anchor the machine. If the machine is likely to vibrate, fix the machine to the floor with anchor bolts.

Shock absorption steel plates are provided and can be placed under each leveling bolt to prevent their sinking into the concrete floor.

## **Installing roller table (optional)**

The roller table is used to support long material at the rear and/or the front of the machine.

If you have ordered the optional roller table for cutting long material, position it before or behind the machine.

Level the roller table and the stand with the machine by adjusting the leveling bolts.



Adjust bolts



## **Installing Fire Control Device**

Install a fire extinguisher or any other fire control device in the shop in case a fire breaks out.

## **RELOCATING**

We recommend you follow these procedures when relocating or shipping your machine to other place:

1. Descend the saw frame to its lowest position then turn off the power.
2. Fix the saw frame using the shipping bracket that originally came with the machine.
3. If you are shipping the machine, pack the machine carefully with industrial plastic wraps to protect it from dust.
4. Use a crane or forklift to raise it. If a crane is used to lift the machine, ensure that the lifting cable is properly attached to the machine.
5. Do not forget to include the equipments originally furnished including the shock absorption steel plates and the instruction manual.

# *OPERATING*

# *INSTRUCTION*

**SAFETY PRECAUTIONS**

**BEFORE OPERATING**

**CONTROL PANEL**

**STANDARD ACCESSORIES**

**OPTIONAL ACCESSORIES**

**UNROLLING & INSTALLING THE BLADE**

**ADJUSTING WIRE BRUSH**

**PLACING WORKPIECE ONTO WORKBED**

**POSITIONING WORKPIECE**

**ADJUSTING BLADE SPEED**

**ADJUSTING COOLANT FLOW**

**BREAKING-IN THE BLADE**

**TEST-RUNNING THE MACHINE**

**CUTTING OPERATION**

**USING TOP CLAMP FOR BUNDLE CUTTING**

**TERMINATING A CUTTING OPERATION**

## **SAFETY PRECAUTIONS**

For your safety, please read and understand the instruction manual before you operate the machine.

The operator should always follow these safety guidelines:

- The machine should only be used for its designated purpose.
- Do not wear gloves, neckties, jewelry or loose clothing/hair while operating the machine.
- For eye protection, always wear protective safety glasses.
- Check the blade tension and adjust blade guides before starting the machine.
- Use auxiliary clamping or supporting devices to fix material in place before cutting long workpieces. Always make sure the material is clamped firmly in place before starting to cut.
- Do not remove jammed or cut-off pieces until the blade has come to a full stop.
- Keep fingers away from the path of the blade.
- Protection devices should be in place at all times. For your own safety, never remove these devices.
- Disconnect machine from the power source before making repairs or adjustments.
- Wear protection gloves only when changing the blade.
- Do not operate the machine while under the influence of drugs, alcohol or medication.
- Do not take your eyes off the machine while in operation.
- Do place warning signs to mark out machine work zone and restrict entry to be staff-only.

## BEFORE OPERATING

Choosing an appropriate saw blade and using the right cutting method is essential to your cutting efficiency and safety. Select a suitable saw blade and cutting method based on your work material and job requirements e.g. cutting accuracy, cutting speed, economic concern, and safety control.

### Wet cutting

If you choose dry cutting or low-speed cutting, the chips may accumulate in machine parts and may cause operation failure or insulation malfunction. We suggest you choose wet cutting to avoid machine damage.

### Cutting unknown materials

Before cutting an unknown material, consult the material supplier, burn a small amount of chips from the material in a safe place, or follow any other procedure to check if the material is flammable.



Never take your eyes off the machine while in operation.

### Cutting fluid

For cooling and lubrication purpose, we recommend you use water-soluble cutting fluids. The following table lists out its pros and cons for your reference.

Pro	Con
<ul style="list-style-type: none"><li>• Have a high cooling effect</li><li>• Not flammable</li><li>• Economical</li><li>• Does not require cleaning of the cut products</li></ul>	<ul style="list-style-type: none"><li>• Remove machine paint</li><li>• Lose its rust protection effect if deteriorated</li><li>• Tend to create foam</li><li>• Subject to decay</li><li>• Decline in performance, depending on the quality of the water used for dilution</li></ul>



Never use water as your coolant.



Always add coolant into water for better mix result.



Consult your coolant supplier for bandsaw use regarding coolant type and mix ratio.



Before starting a cutting job, make sure there is sufficient amount of coolant in the tank.

Check the fluid level through the sight gauge. Please refer to machine specifications in this manual (Section 2) for tank capacity.

## CONTROL PANEL

The control panel is located on the top of the electrical box. It includes the following function: power system, hydraulic system, cooling system and the human-machine–interface (HMI). The operator must fully understand the function of each switch and button before operating the machine.

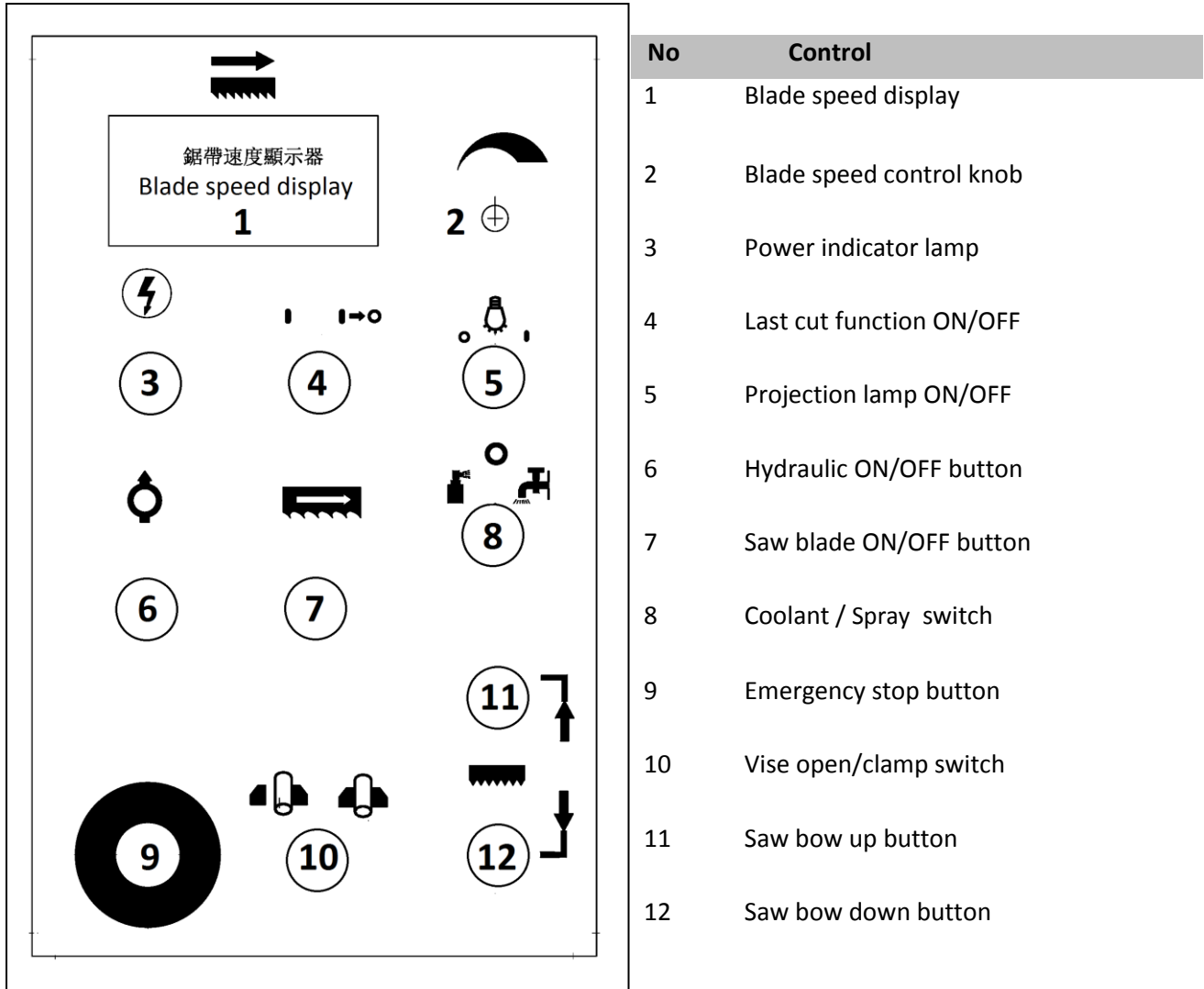



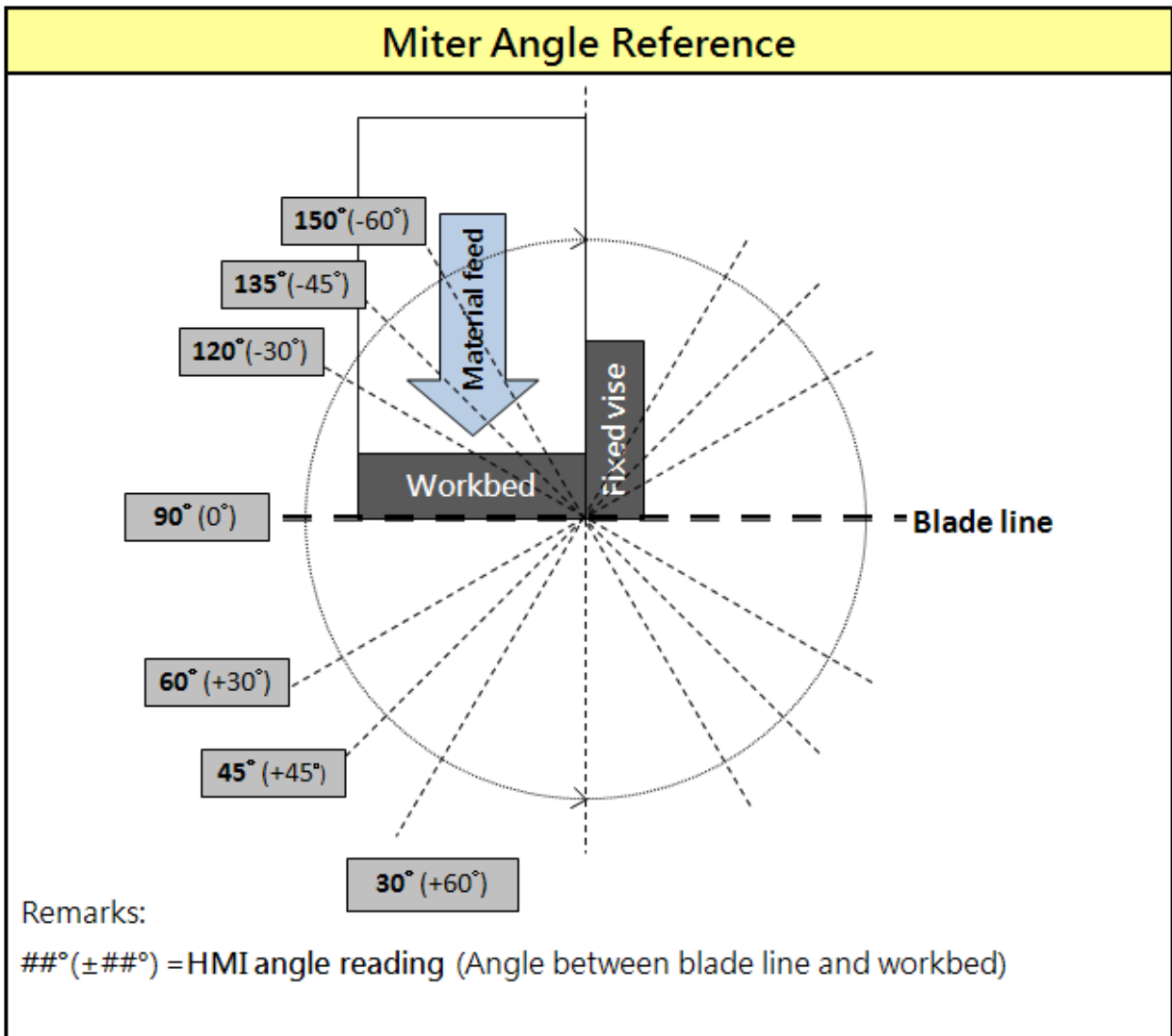

## Control Buttons

### 1. Blade speed display

Displays current blade speed.

### 2. Blade speed control knob

Blade speed is controlled by the inverter located under the workbed. Turning the knob clockwise increases the blade speed.

### 3. Power indicator lamp

When the lamp is on, it indicates the power to the machine is turned on.

### 4. Last cut function ON/OFF



STOP /



ON :



When the  mode is selected, the blade will automatically stop and the hydraulic system will shut down (in 10 seconds) after the current cut is finished.

## 5. Projection lamp ON/OFF



OFF /



ON :



mode is selected, projection lamp will OFF.

## 6. Hydraulic ON/OFF button

O ( Red ) : Press this button to turn off the hydraulic motor immediately.

I ( Green ): Press this button to turn on the hydraulic motor immediately.

## 7. Saw blade ON/OFF button

O ( Red ) : Press this button to stop the blade.

I ( Green ): press this button to start cutting.

## 8. Coolant / Spray switch



Coolant /



Spray

Only  SPRAY or  Coolant can be selected.

## 9. Emergency stop button

Press this button to stop the machine in an emergency. When the button is pressed, it brings the machine to a full stop. The button locks when pressed. In order to unlock it, please turn the button clockwise.

## 10. Vise OPEN / CLAMP switch

When turning the switch to the left, the vises will open until the operator lets go of the button or until the vises are fully opened. When turning the switch to the right, the vises will clamp until the operator lets go of the button. Turn and hold the switch to the right for three seconds and let go of it; the vise will automatically close until it is fully clamped.

## 11. Saw bow up button

When this button is pressed, the saw bow rises until the operator lets go of the button or until the saw bow reaches the highest position and touches the upper limit switch. Under cutting mode, press and hold this button for three seconds and the saw bow rises automatically to its highest position.



While pressing the saw bow up button can stop the running blade, please still use the emergency stop button in an emergency.

## 12. Saw bow down button

When this button is pressed, the saw bow descends until the operator lets go of the button or until the saw bow reaches the lowest position and touches the lower limit switch.

## Blade descend pressure and speed

The part of control panel is where cutting pressure and saw bow descend speed can be adjusted.

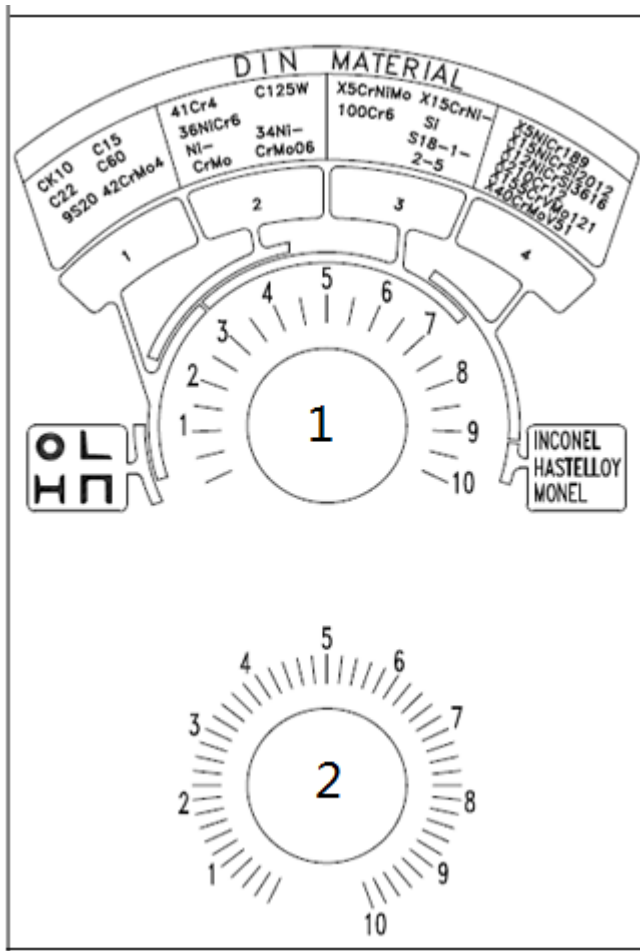

### 1. Cutting pressure control knob

- This pressure control knob is used to adjust the cutting pressure of the blade.
- Turning the knob clockwise increases the cutting pressure.
- To obtain a good cutting result, choose the right cutting pressure by turning the knob until it points to your material on the color chart.

### 2. Blade descend speed control knob

- This knob is used to adjust the descend speed of the saw blade.
- Turning the knob clockwise increases the blade descend speed.
- Blade descend speed is a determining factor to a good cutting time and quality cutoff surface.
- Set the blade descend speed in accordance with the *cutting pressure control* knob.

Also commonly known as the flow control valve.

## STANDARD ACCESSORIES

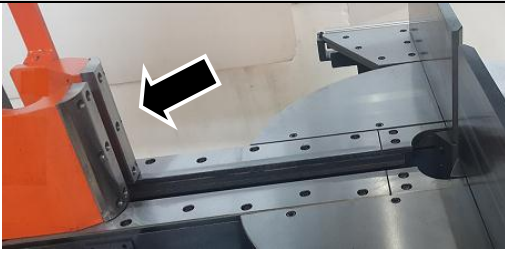

### Split front vises

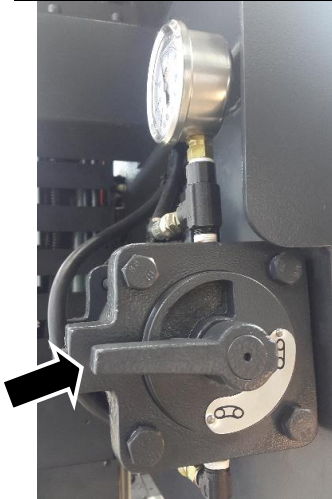

The split vises are a clever design to make sure your workpiece is tightly clamped by the two vises from both sides of the blade, maximizing stability and cutting precision.

### Blade tension device



- This blade tension device equipped with hydraulic cylinder provides appropriate tension to the saw blade.
- To tighten the saw blade, turn the selector to .
- Upon saw blade breakage, the safety device will activate and automatically stop all machine operation.
- To change the blade, turn the handle to  to release saw blade tension.



Never adjust blade tension while the blade is running.

### Blade speed/motion detector

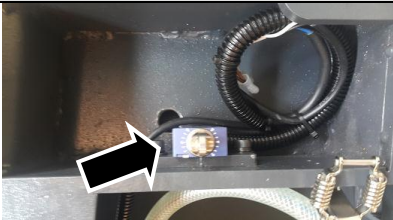

- Besides detecting the blade speed, the speed/motion detector also functions as a safety device.
- The speed/motion detector protects operators and the machine by preventing blade overloads and consequent damages if a saw blade breaks or skids.
- Once blade breakage or slippage is detected, the drive wheel will stop in 10 seconds.

### Inverter

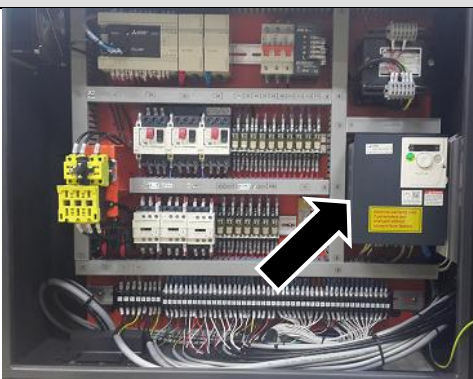

This inverter is installed inside the machine base. It is used to control and stabilize the saw blade speed during cutting.

To adjust blade speed, use the *blade speed control* knob on the control panel.



Voltage used should not exceed AC 460V.



**Note:**

1. Make sure the terminal points are connected.
2. Make sure the ambient temperature is within acceptable range and keep the surroundings well ventilated.
3. Keep the inverter away from dust.
4. For repair or maintenance, please contact your local agent.

## Gear reducer

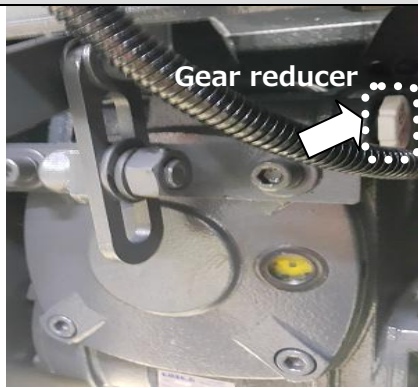

The specially designed gear reducer can work toward your preset blade speed and torque.



Please refer to Chapter 8 for information on maintenance.

## Coolant Pump



The coolant pump supplies coolant to cool off cutting temperatures during cutting. Also, it can be used to wash off chips.

## Wire Brush



The wire brush is driven by the belt to rotate at the same speed as the blade motor. It removes the metal chips on the saw blade teeth so that blade life can be extended.



Keep hands away from the transmission shaft and the brush while the wire brush is running.



Turn off the hydraulic motor or the main power switch before performing maintenance or cleaning on the wire brush drive system.

## Hydraulic top clamp device

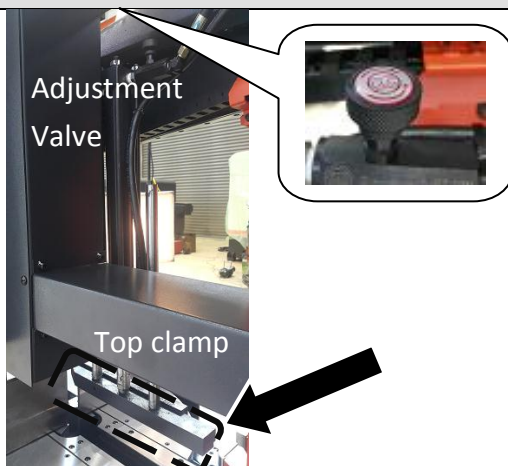

- The device is installed on the saw bow.
- Used for cutting bundles, the top clamp will hold the material tightly so as to avoid material sliding during cutting.
- Use the adjustment valve to adjust its speed during clamping/unclamping.
- When the vise moves, the top clamp will act in synchronization.

## OPTIONAL ACCESSORIES

### Vise Pressure Regulator

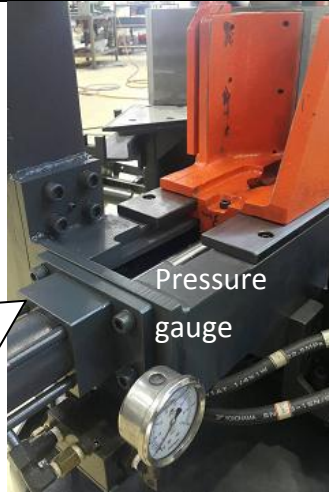

- This adjustment valve is used to control vise pressure.
- Adjust vise pressure based on the material of your workpiece.
- When cutting pipes or soft materials, reduce vise pressure to prevent exerted pressure from damaging the workpiece shape or exterior.



Do not adjust vise pressure at any time during cutting.



Vise pressure should never be lower than  $8 \text{ kg/cm}^2$ .

### Chip conveyor

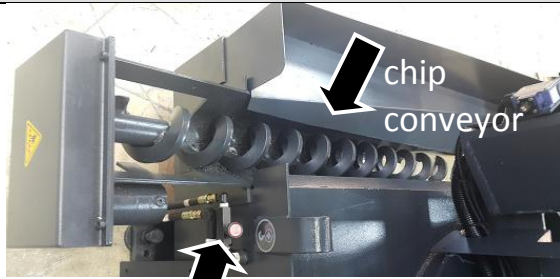

Pressure valve

Chip conveyor is a spiral device to bring chips out during cutting. When the hydraulic system is turned on, the user can adjust the conveying speed via the pressure valve.



As a regular maintenance, remove the chip conveyor and clean all chip deposits inside.

### Vibration Damper

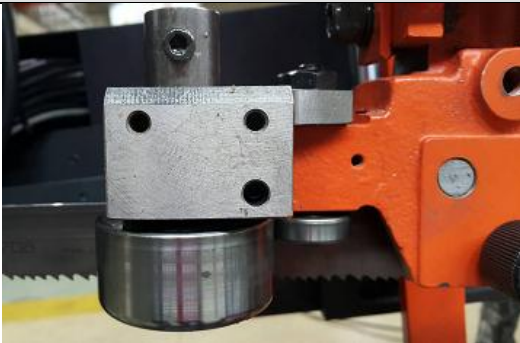

Vibration damper roller is installed on the left saw arm. It reduces the high frequency noise while cutting large work piece.

### Blade Deviation Detector & Calibration Procedure



This device detects blade deviation. If the blade deviates beyond the preset range, the machine will stop automatically. When this device is installed, the cutting width will be reduced. The blade deviation detected value and preset values are displayed on the HMI screen.

Before cutting, please make sure if the deviation value is within  $\pm 0.03 \text{ mm}$  ( $0.0012''$ ). If not, please calibrate the deviation detector before proceeding to cutting.

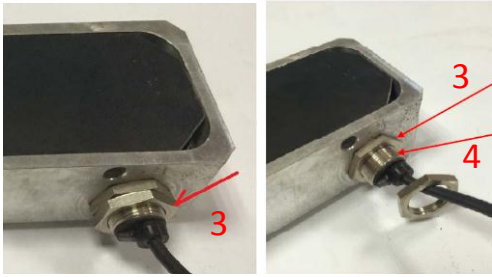

### How to Check & Adjust

1. Start the hydraulic motor. Turn on the deviation function. Start the saw blade and let it run for 1~2 minutes..
2. Stop the saw blade. Observe the deviation value while the saw blade is completely still.
3. If the deviation value is out of  $\pm 0.03$  mm, loosen outer nut first then the inner nut.
4. Adjust the proximity switch until the deviation value is within  $\pm 0.03$  mm.
5. Tighten inner nut back then the outer nut.



If the deviation value is not changing while adjusting the proximity switch, try pulling below roller. If deviation value is still not changing, it means the proximity switch is broken.

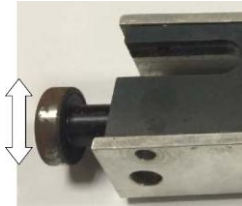

### 2M Roller Table



- The optional 2M roller table supports the work material and ensures the material is fed in smoothly.

### Spray device



- This device is for cutting aluminum.
- Spray on blade during cutting period.
- Easy to control and clean the chips on the blade.

## Projection Light

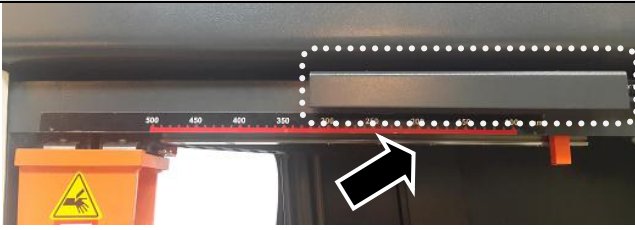

Activate the switch to project a beam of light on the work piece. The operator can use the light as reference to adjust the cutting dimension of the work piece.

## UNROLLING & INSTALLING THE BLADE



Always wear leather gloves and protection glasses when handling a blade.

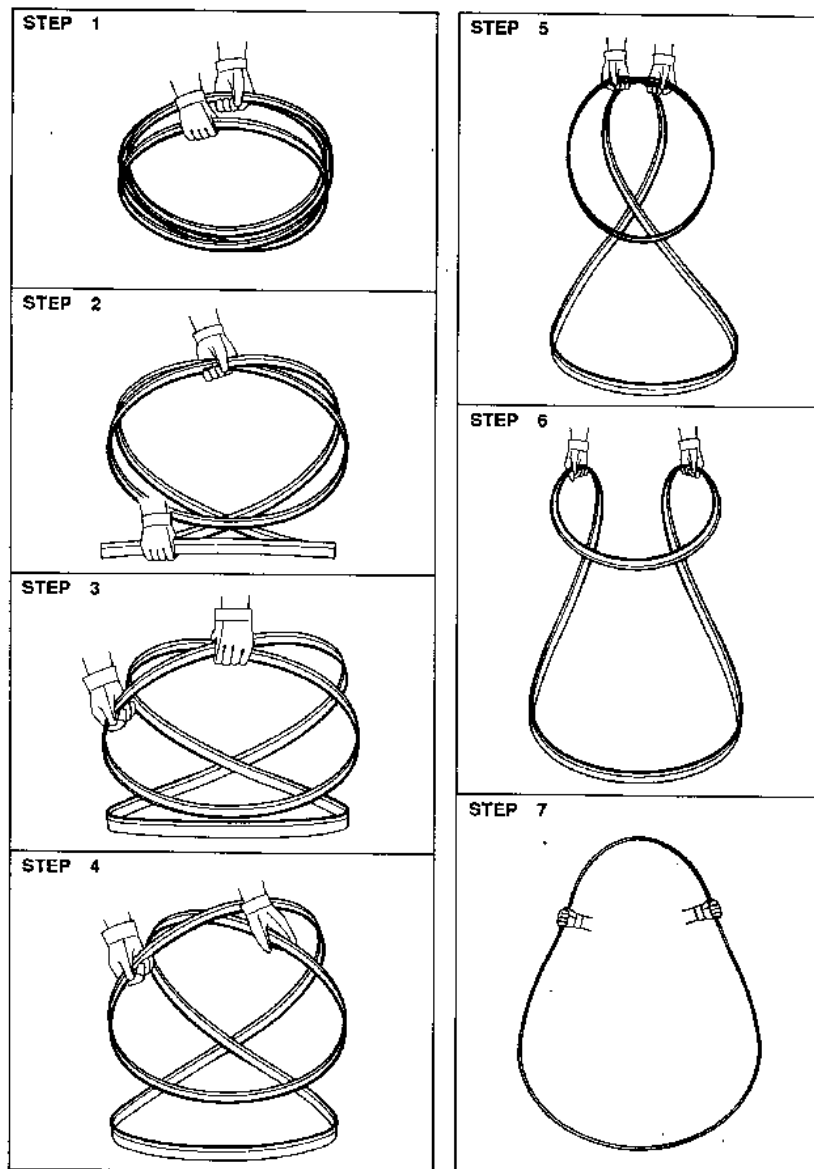

### Unrolling the blade

Please follow the procedures illustrated below.





### Installing a new blade

- Step 1 - Select the most suitable saw blade for your workpiece considering the size, shape and material.
- Step 2 - Turn on the machine power by switching to *ON* and turn on the hydraulic system.
- Step 3 - Press the *saw bow up* button and elevate the saw bow to an appropriate height.
- Step 4 - Turn the tension controller handle from “” to “” position to release tension. The idle wheel will then move slightly toward the direction of the drive wheel.
- Step 5 - Open the idle and drive wheel cover.
- Step 6 – Loosen the wire brush assembly fixed screws and pull the wire brush away from the blade.
- Step 7 – Loosen the left and right carbide inserts. Detach the old blade from below the left and right guide seat and then pull the entire blade out.
- Step 8 - If necessary, clean the carbide inserts before installing a new saw blade.
- Step 9 - Place the new blade around the idle wheel and the drive wheel
- Step 10 - Insert the blade into the left and right tungsten carbide inserts. The back and the sides of the blade need to be touching the inserts as well as the adjacent rollers.
- Step 11 - Place the blade to the drive wheel and press the back of the blade against the flange of the drive wheel.
- Step 12 - Make sure the back of the blade is also pressed against the flange of the idle wheel.
- Step 13 - Turn the tension controller handle to [] position to obtain blade tension.
- Step 14 - Make sure the sides of the blade are in close contact with the carbide inserts and then tighten the left and right carbide inserts.
- Step 15 – Gently close the idle and drive wheel covers.
- Step 16 - Press the *saw blade start* button to start the blade. Allow the blade to run for a few rotations then press the *saw bow up* button to elevate the saw bow. Open the wheel covers and make sure the blade has not fallen off the drive and idle wheels. If the blade has shifted, follow the same procedure to reinstall the blade again.
- Step 17 - Adjust wire brush to a proper position. Refer to *Adjust wire brush* in this section.

### **ADJUSTING WIRE BRUSH**

Follow these steps to adjust wire brush to appropriate position:

- Step 1 – Open the drive wheel cover.
- Step 2 – Loosen the lock lever.
- Step 3 – Adjust the screw to make brush move up / down until it makes proper contact with the saw blade (see below illustration).
- Step 4 – Tighten the lock lever.
- Step 5 – Close the drive wheel cover.

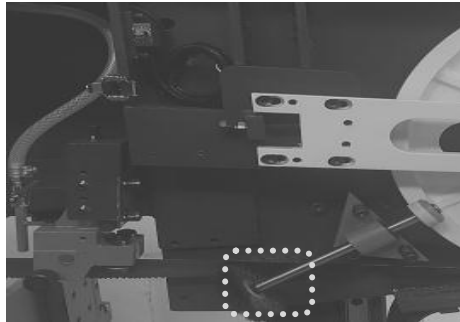

Proper

Improper

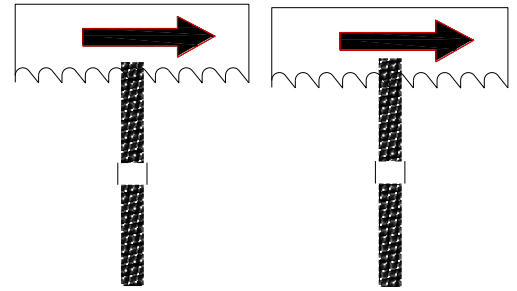

## PLACING WORKPIECE ONTO WORKBED

- Step 1 – Press the *saw bow up* button and elevate the saw bow until it reaches to its highest point.
- Step 2 – Turn the *vise open/clamp* switch to the left to open vise.
- Step 3 – Carefully place the workpiece onto the work feed table.

## POSITIONING WORKPIECE FOR CUTTING

Follow these steps to position your workpiece:

Step	Action
vise clamp material	<b>1</b> Turn the <i>vise open/close</i> switch to the right until the workpiece is securely clamped.
confirm cutoff point	<b>2</b> Press the <i>saw bow down</i> button to lower the saw bow until it descends to just about 10mm (0.4 inch) above the workpiece.
precision position	<b>3</b> Adjust until the cutoff point on the workpiece aligns with the blade line.

## ADJUSTING BLADE SPEED

- Step 1 – Set the flow control to “0” position.
- Step 2 – Press the *saw blade start* button to start the blade.
- Step 3 – Turn the *blade speed control knob* to adjust the blade speed. The blade speed should be adjusted based on the size and the material of the workpiece.

## ADJUSTING COOLANT FLOW

Step 1 – Press the *saw blade start* button to start the saw blade drive motor.

Step 2 – Press the *saw bow down* button to lower the saw bow.

Step 3 – Use the flow control valve (shown below) to adjust the amount of fluid flowing to the cutting area.

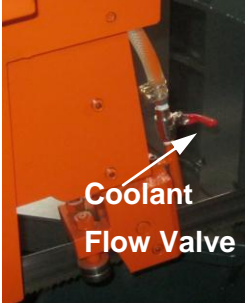

Adjust the flow amount if you observe the following changes to the chips generated from cutting.

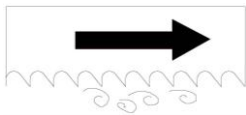

If the chips are sharp and curved, increase the coolant flow amount.

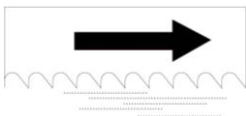

If the chips are granulated, decrease the coolant flow amount.

## BREAKING-IN THE BLADE

When a new saw blade is used, be sure to first break in the blade before using it for actual, extended operation. Failure to break in the blade will result in less than optimum efficiency. To perform this break-in operation, the following instructions should be followed:

Step 1 - Reduce the blade speed to one-half of its normal setting.

Step 2 - Lengthen the cutting time to 2-3 times of what is normally required.

Step 3 - After the break-in operation is completed, set all parameters back to normal settings.

## TEST-RUNNING THE MACHINE

Test-running this machine can ensure good machine performance in the future. We suggest you run the following tests on the machine before first use:

### **Testing machine performance:**

Turn on the power and run a basic performance test after you finish installing the machine. Follow these steps to test machine performance:

Step 1 – Disassemble shipping brackets and bolts.

Step 2 – Install roller table (optional).

Step 3 – Turn on the relay switch in the control box.

Step 4 – Elevate the saw bow. (If your coolant pump is in reverse and the machine cannot run, please change the electrical phase.)

Step 5 – After the saw bow ascends, extend the quick approach device(optional).

Step 6 – Remove the rust-prevention grease with cleaning oil or kerosene.

Step 7 – Start the coolant pump.

Step 8 – Test these functions under manual mode:

- vise clamping/unclamping
- saw bow ascending/descending
- feeding forward and backward.

## CUTTING OPERATION

Step 1 – Check before you cut

- **Power:** Check the voltage and frequency of your power source.
- **Coolant:** Check if you have sufficient coolant in the tank.
- **Hydraulic:** Check if you have sufficient (at least two-thirds or higher) hydraulic oil.
- **Workbed:** Check if there is any object on the feeding bed that may cause interference.
- **Blade:** Check the blade teeth and make sure there is no worn out teeth along the blade.
- **Light:** Check the work lamp or laser light (optional) and make sure there is sufficient lighting.
- **Roller:** Check all the rollers on the front and rear workbed can roll smoothly.
- **Saw bow:** Check the saw bow to see if it can be elevated and lowered smoothly

Step 2 – Place your workpiece onto the workbed manually or by using a lifting tool e.g. a crane.



Before loading, make sure the vises are opened to at least wider than the width of the workpiece.

Step 3 – Position your workpiece.

Step 4 – Clamp the workpiece.

Step 5 – Turn the *cutting pressure control* knob to adjust blade cutting pressure according to the material.

Step 6 – Adjust *blade descend speed control* knob to obtain a suitable blade descend speed for your material.

Step 7 – Start running the blade.



Before you start cutting, check again that there is no other object in the cutting area.

Step 8 – While the blade descends, adjust the blade speed if necessary. You can do so by turning the *blade speed control* knob, clockwise to speed up and counterclockwise to slow down. The blade speed is displayed in the HMI touch screen.

Step 9 – Select the proper cutting condition according to different material.

Step 10 – After the entire cutting job is completed, elevate the saw bow to the top and open the vises to remove the workpiece.

Step 11 – Clean the workbed by removing chips and cutting fluids.

Step 12 – Lower the saw bow to a proper position then turn off the power.

## USING TOP CLAMP FOR BUNDLE CUTTING

Step 1 – Open the adjustment valve of top clamp.

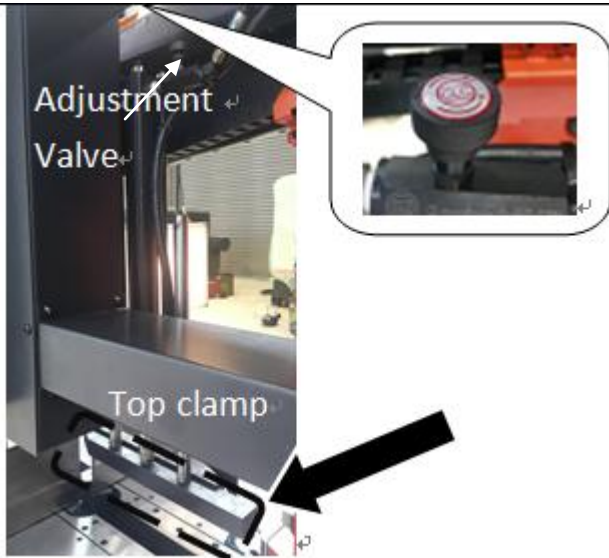

Step 2 – Position the workpiece for bundle cutting.



Note the allowable clamping width and height. (Refer to *Section 2 – General Information, Specifications*)

### Proper and improper stacking of workpieces

Proper

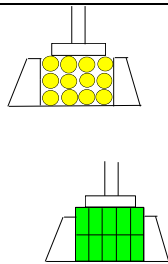

Improper

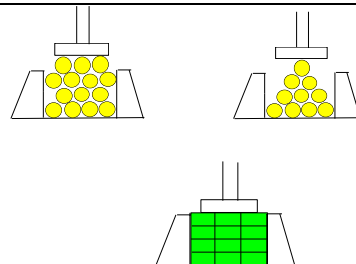

Step 3 – Install the bundle-cutting on the work bed. The purpose of bundle cutting is to prevent cut pieces from scattering across the work bed.

Step 4 – For subsequent cutting procedures, refer to the instructions under cutting operation.



## TERMINATING A CUTTING OPERATION

- To terminate a cutting operation, press either the *saw bow up* button or the *saw blade stop* button.
- The saw blade will stop running when the *saw bow up* button or the *saw blade stop* button is pressed.
- The machine will stop automatically when an error occurs. The error message will be shown on the screen.

Section 5

# *ELECTRICAL SYSTEM*

**ELECTRICAL CIRCUIT DIAGRAMS**

# 經濟型面板

Control panel (Standard model)

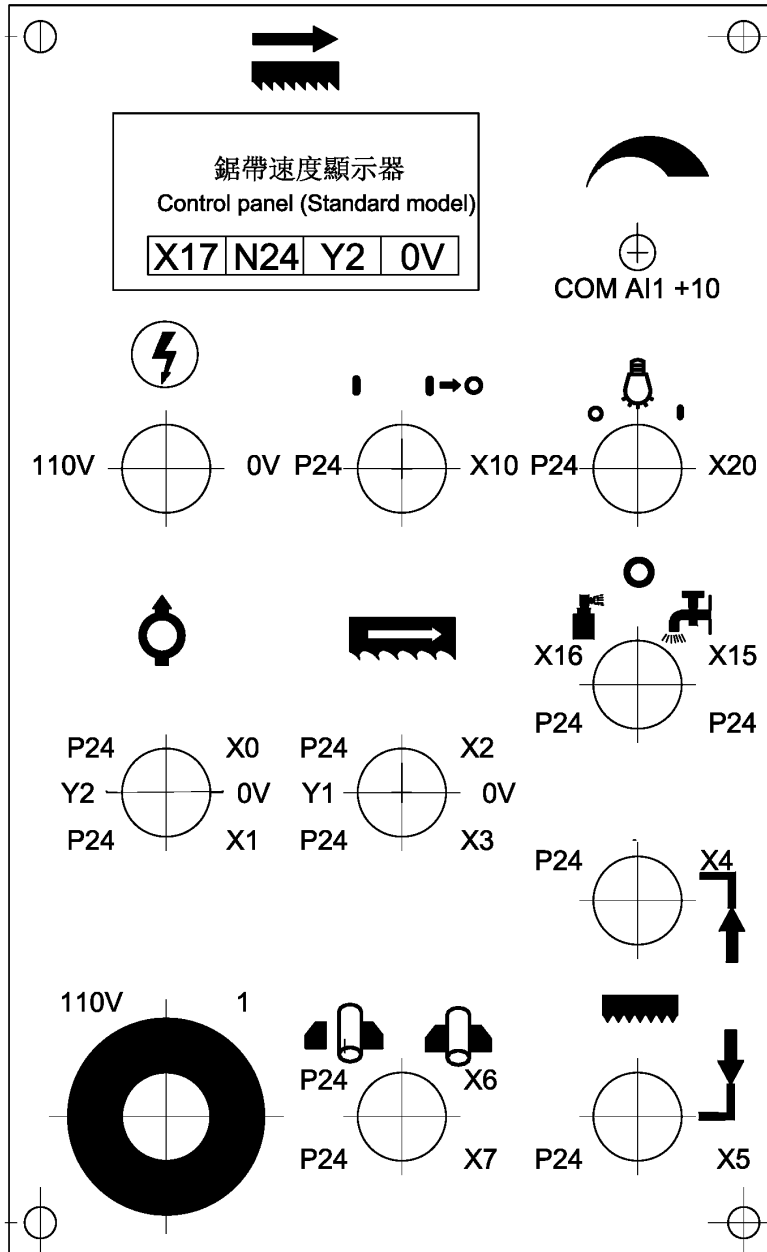



110V
0V
1
Y1
P24
X0
X1
X2
X3
X4
X5
X6
X7
X10
X15
X16
X17
X20

TB1

⊕	N24	X1	X3	X5	X7	X15	X17	X21	X23	X25	X27
⊖	S/S	X1	X3	X5	X7	X11	X13	X15	X17	X21	X23
L	N	X0	X2	X4	X6	X10	X12	X14	X16	X20	X24
1	0V	X0	X2	X4	X6	X10	X12	X14	X16	X22	X26

**FX3G-40MR**

Y0	Y1	Y2	Y4	Y6	Y10
0V	Y0	Y1	Y2	Y4	Y6
24V	COM0	COM1	COM2	Y3	COM3
1	1	1	1	1	1
Y11	Y13	COM4	Y11	Y13	COM5
Y17	Y17	Y17	Y17	Y17	Y17

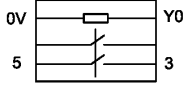
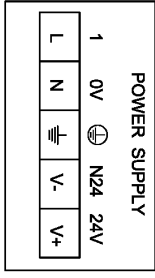
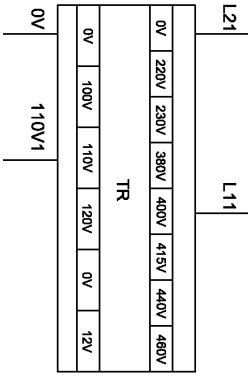

L1
L2
L3
PE
U
V
W
⊕
S1
V1
W1
⊖
U2
V2
W2

TB2

12V2
12V0V
Y4
0V
Y5
Y6
Y7
0V
Y10
Y11
Y17
0V
0V
1
Y13
⊕
X12
P24
X21
X22
P24
X25
X26
P24
N24
X17
X23
P24
N24
X24
X27
P24
N24

TB3

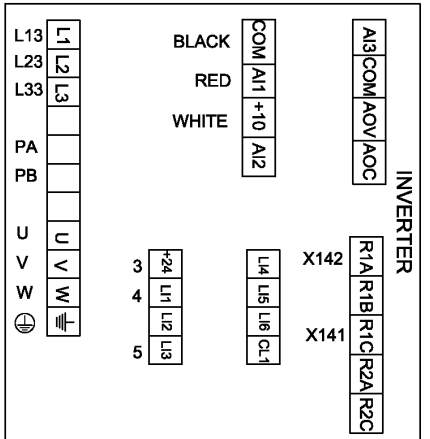
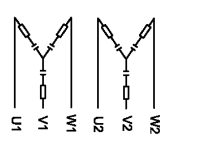
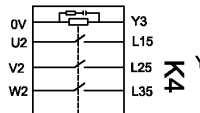
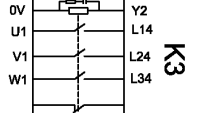
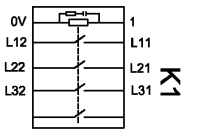
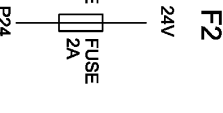
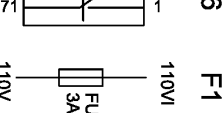
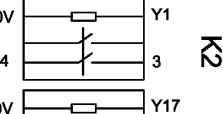
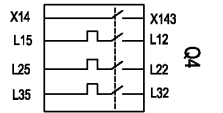
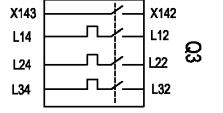
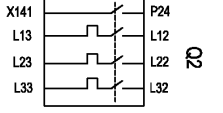
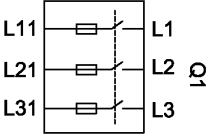

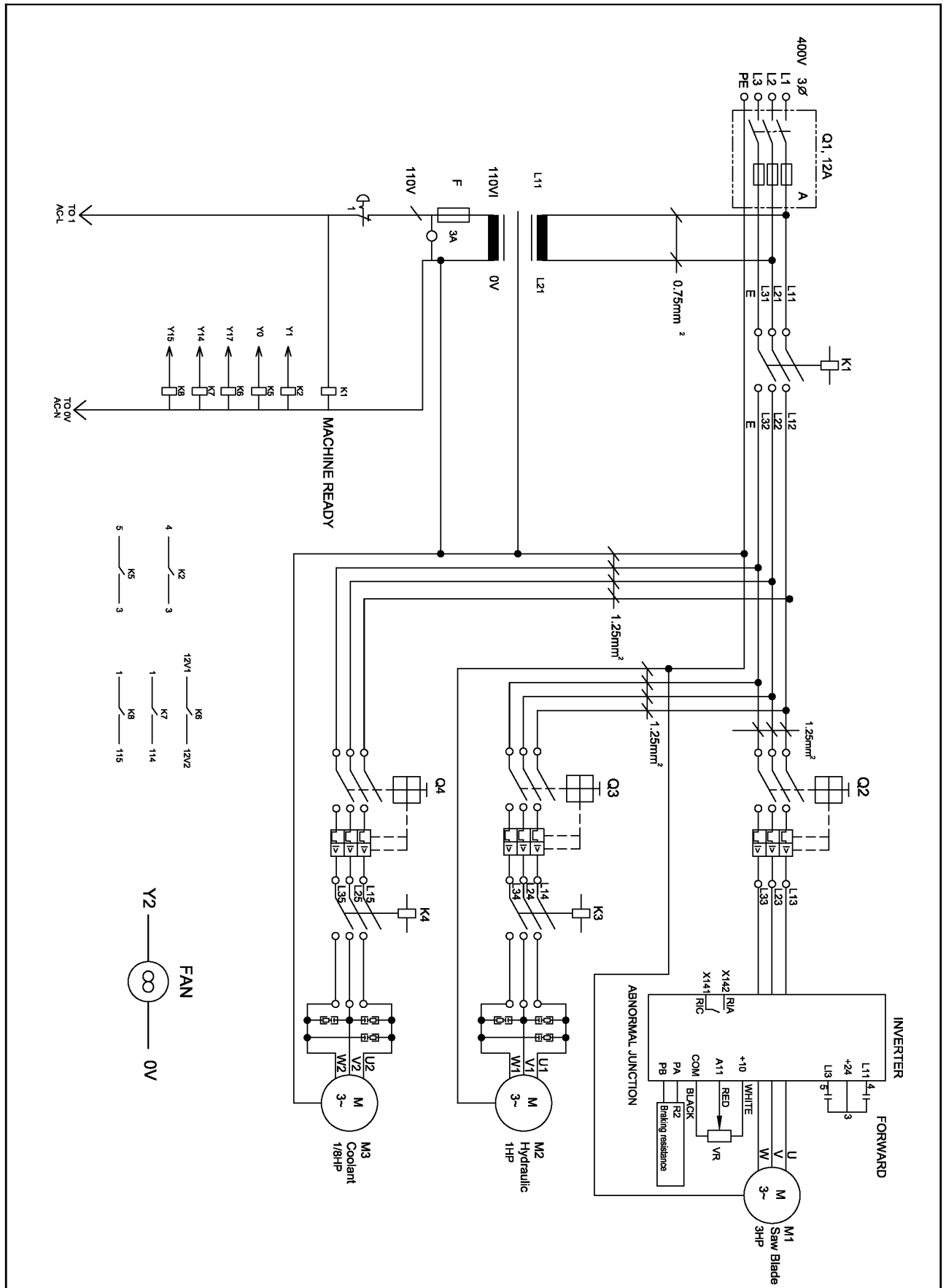

高聖精密機電股份有限公司 COSEN MECHATRONICS CO., LTD.	圖名	動力配置圖 Power supply Layout	圖號	EL-SH510LDM-F17-002S0-C	繪圖	林泰維	日期	20180126	版本	20180126
					審核	林泰維	日期	20180126		S0

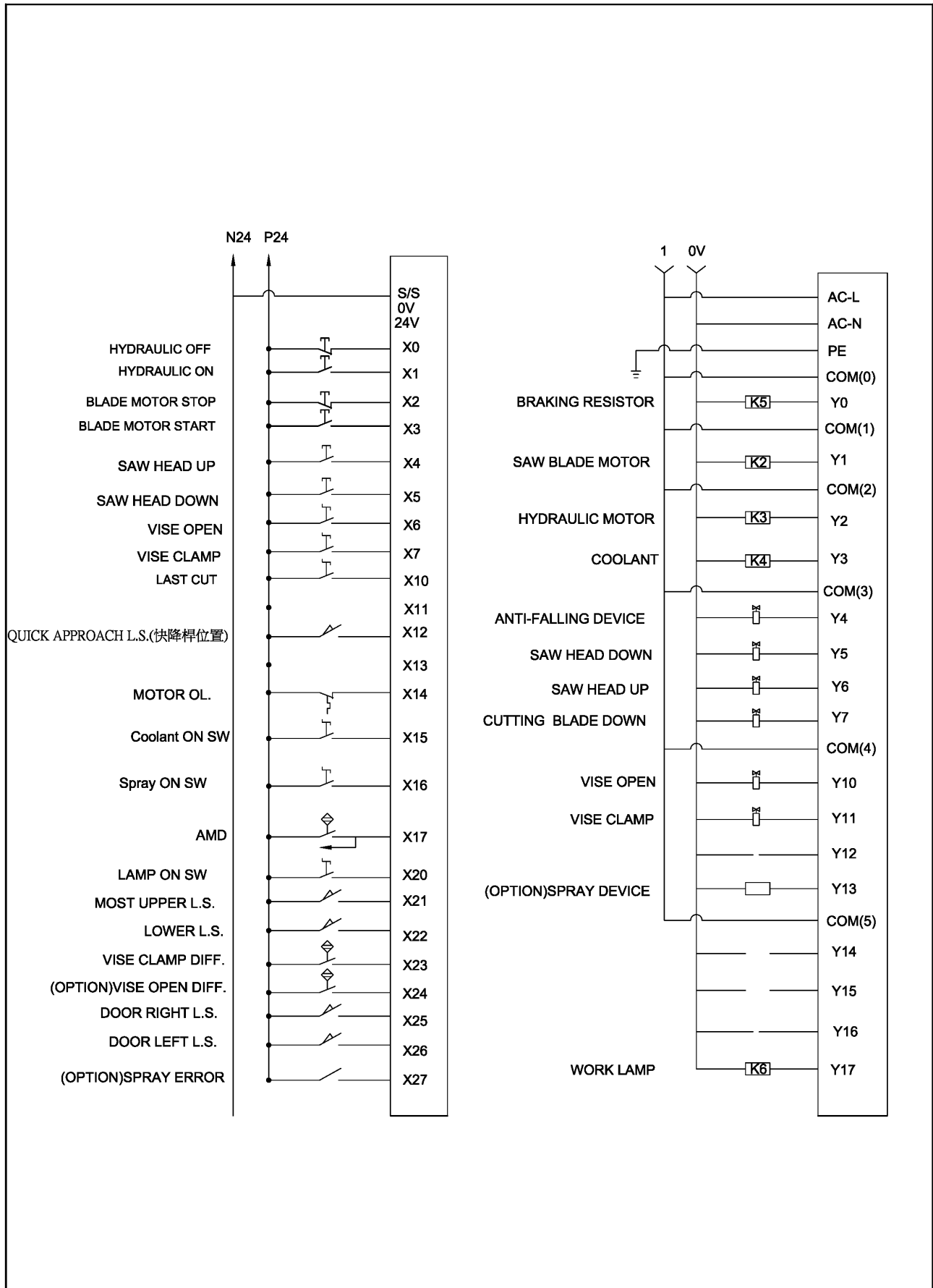

高聖精密機電股份有限公司 COSEN MECHATRONICS CO., LTD.	<b>圖名</b> PLC I/O配置圖 PLC Input/Output Layout	<b>圖號</b> EL-SH510LDM-F17-002S0-E	<b>繪圖</b> 林泰維	<b>日期</b> 20180126	<b>版本</b>
			<b>審核</b> 林泰維	<b>日期</b> 20180126	

Blade speed display  
鋸帶速度表

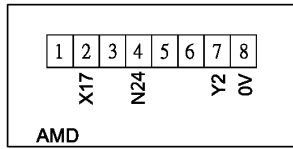

OPTION  
選配

0V 1

OPTION

選配

Lubrication system Mitsubishi PLC  
冷卻潤滑噴霧組線路圖 (三菱PLC)

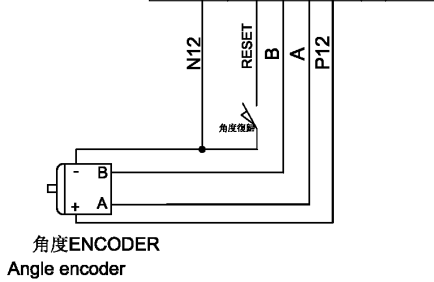
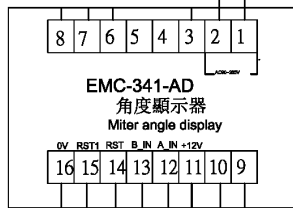

角度ENCODER  
Angle encoder

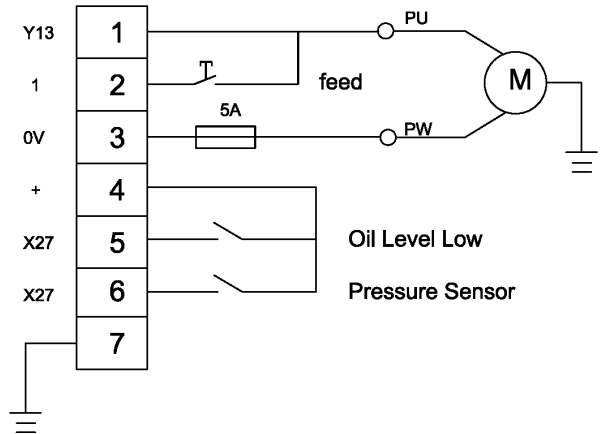

高型精密機電股份有限公司 COSEN MECHATRONICS CO., LTD.	圖名	角度顯示&鋸帶速度	圖號	EL-SH510LDM-F17-002S0-E	繪圖	林泰維	日期	20180126	版本
					審核	林泰維	日期	20180126	SO

*Section 6*

# *HYDRAULIC SYSTEM*

**HYDRAULIC DIAGRAMS**

**COSEN**

HYDRAULIC CIRCUIT

SH-510DM HYDRAULIC CIRCUIT

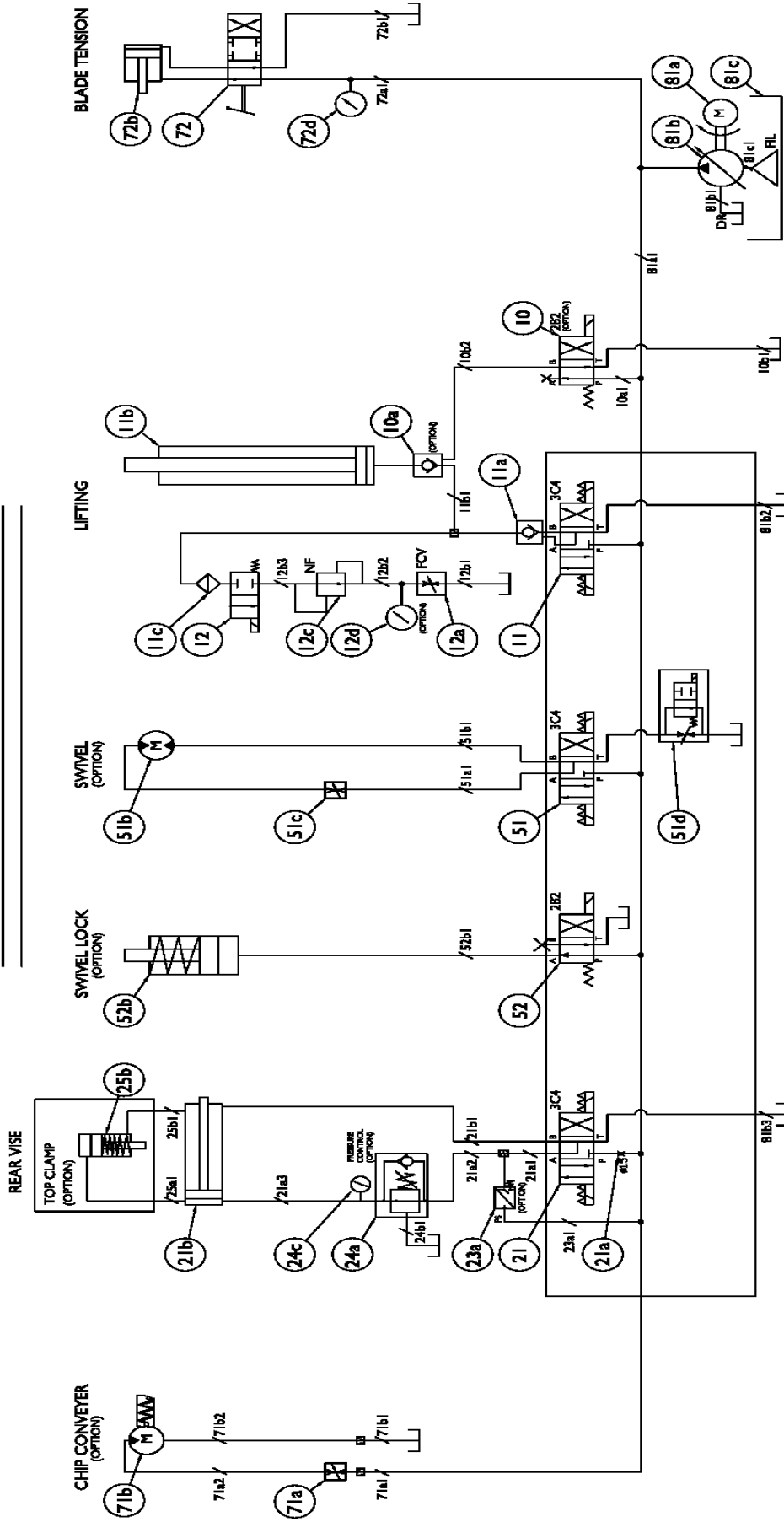

COSEN MECHATRONICS CO.,LTD.

SHELBY

20180115

DRAW

SH-510DM HYDRAULIC CIRCUIT

VERSION 1-0

CHECK

APPROVED

DATE

NAME

DATE

NAME

# *Section 7*

## *BANDSAW CUTTING: A PRACTICAL GUIDE*

**INTRODUCTION**

**SAW BLADE SELECTION**

**WISE LOADING**

**BladeBreak -In**

**SOLUTIONS TO SAWING PROBLEMS**

## INTRODUCTION

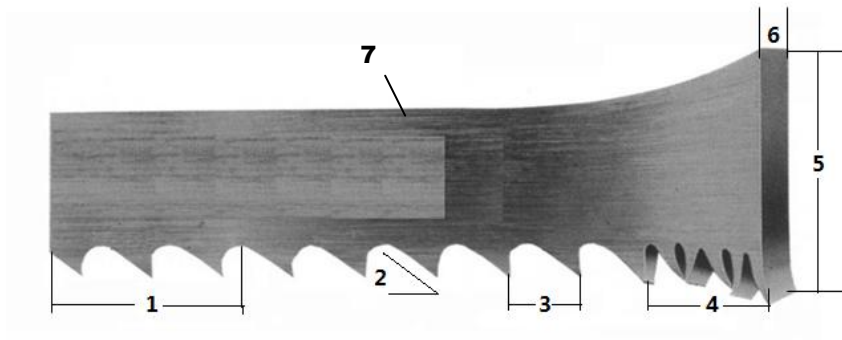

- 1. TPI:** The number of teeth per inch as measured from gullet to gullet.
- 2. Tooth Rake Angle:** The angle of the tooth face measured with respect to a line perpendicular to the cutting direction of the saw.
- 3. Tooth Pitch:** Tooth pitch refers to the number of teeth per inch (tpi). 1 inch equates to 25.4 mm.

A distinction is made between constant tooth pitches with a uniform tooth distance, 2 tpi for example, and variable tooth pitches with different tooth distances within one toothing interval.

Variable tooth pitches, for instance 2-3 tpi, can be characterized by two measures: 2 tpi stands for the maximum tooth distance and 3 tpi stands for the minimum tooth distance in the toothing interval.

### Constant



### Variable

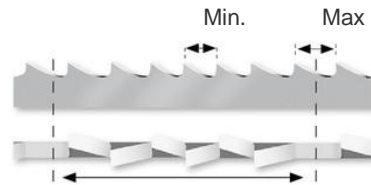

- 4. Set:** The bending of teeth to right or left to allow clearance of the back of the blade through the cut.
- 5. Width:** The nominal dimension of a saw blade as measured from the tip of the tooth to the back of the band.
- 6. Thickness:** The dimension from side to side on the blade.
- 7. Gullet:** The curved area at the base of the tooth. The tooth tip to the bottom of the gullet is the gullet depth.

## SAW BLADE SELECTION

### 1. Band length

The dimensions of the band will depend on the band saw machine that has been installed.

Please refer to Section 2 – General Information

### 2. Band width

Band width: the wider the band saw blade, the more stability it will have.

### 3. Cutting edge material

The machinability of the material to be cut determines what cutting material you should choose.



#### 4. Tooth pitch

The main factor here is the contact length of the blade in the workpiece.

If it is 4P,  $25.4 \div 4 P = 6.35$  mm, that is, one tooth is 6.35 mm.

If it is 3P,  $25.4 \div 3 P = 8.46$  mm If the number is small, it means that the tooth is large.

What is written as 3/4 is that it is a variable pitch of large (3) / small (4).

The saw blade must contact the cutting material at least two pitches. In the case of a thickness of 15 mm, 4P = OK, 3P = NG.

- The surface conditions will also affect the cutting rate. If there are places on the surface on the material which are hard, a slower blade speed will be required or blade damage may result.
- It will be slower to cut tubing than to cut solids, because the blade must enter the material twice, and because coolant will not follow the blade as well.
- Tough or abrasive materials are much harder to cut than their machinability rating would indicate.
- Tooth spacing is determined by the hardness of the material and its thickness in cross section.
- Tooth set prevents the blade from binding in the cut. It may be either a "regular set" (also called a "raker set" ) or a "wavy set".
- The regular or raker set is most common and consists of a pattern of one tooth to the left, one tooth to the right, and one which is straight, or unset. This type of set is generally used where the material to be cut is uniform in size and for contour cutting.
- Wavy set has groups of teeth set alternately to right and left, forming a wave-like pattern. This reduces the stress on each individual tooth, making it suitable for cutting thin material or a variety of materials where blade changing is impractical. Wavy set is often used where tooth breakage is a problem. This is shown in Fig. 7.2 as follows:

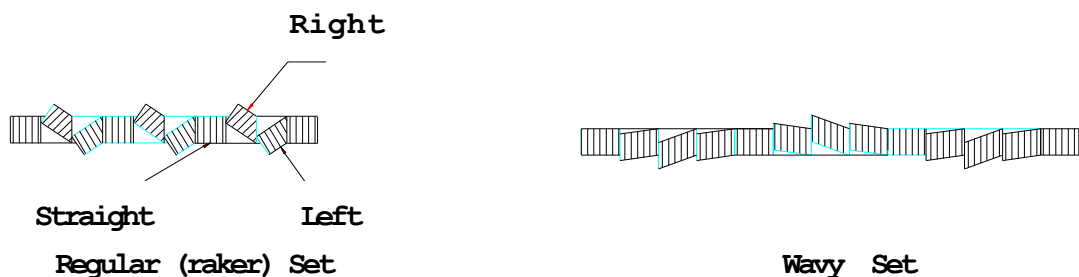

Fig. 7.2 The Saw Set

#### WISE LOADING

The position in which material is placed in the vise can have a significant impact on the cost per cut.

Often, loading smaller bundles can mean greater sawing efficiency.



When it comes to cutting odd-shaped material, such as angles, I-beams, channel, and tubing, the main point is to arrange the materials in such a way that the blade cuts through as uniform a width as possible throughout the entire distance of cut.

The following diagrams suggest some costeffective ways of loading and fixturing. Be sure, regardless of the arrangement selected, that the work can be firmly secured to avoid damage to the machine or injury to the operator.



### **BladeBreak -In**

Completing a proper break-in on a new band saw blade will dramatically increase its life.

**1. Select the proper band speed** for the material to be cut.

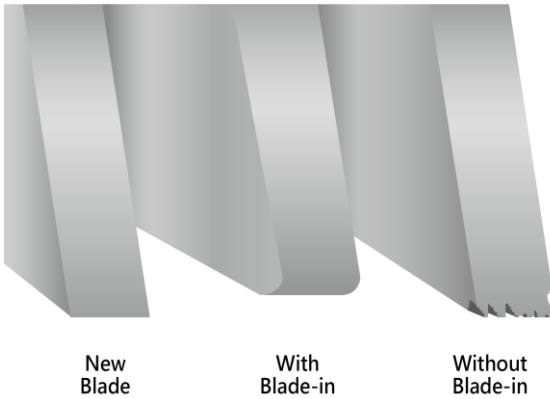

**2. Reduce the feed force/rate** to achieve a cutting rate 20% to 50% of normal (soft materials require a larger feed rate reduction than harder materials).

**3.Begin the first cut at the reduced rate.** Make sure the teeth are forming a chip. Small adjustments to the band speed may be made in the event of excessive noise/vibration. During the first cut, **increase feed rate/force** slightly once the blade fully enters the workpiece. With each following cut, **gradually increase feed rate/force** until normal cutting rate is reached.

# ***MAINTENANCE & SERVICE***

## **INTRODUCTION**

### **BASIC MAINTENANCE**

#### **MAINTENANCE SCHEDULE**

**BEFORE BEGINNING A DAY'S WORK**

**AFTER ENDING A DAY'S WORK**

**EVERY MONTH**

**EVERY THREE MONTHS**

**EVERY SIX MONTHS**

#### **STORAGE CONDITIONS**

#### **TERMINATING THE USE OF MACHINE**

#### **OIL RECOMMENDATION FOR MAINTENANCE**

## **INTRODUCTION**

For the best performance and longer life of the band saw machine, a maintenance schedule is necessary. Some of the daily maintenance usually takes just a little time but will give remarkable results for the efficient and proper operation of cutting.

## **BASIC MAINTENANCE**

It is always easy and takes just a little effort to do the basic maintenance. But it always turns out to be a very essential process to assure the long life and efficient operation of the machine. Most of the basic maintenance requires the operator to perform it regularly.

## MAINTENANCE SCHEDULE

We suggest you do the maintenance on schedule.

### Before beginning a day's work

1. Please check the hydraulic oil level. If oil level volume is below 1/2, please add oil as necessary.(Filling up to 2/3 level is better for system operation.)
2. Please check the cutting fluid level, adding fluid as necessary. If the fluid appears contaminated or deteriorated, drain and replace it.
3. Please check the saw blade to ensure that it is properly positioned on both the drive and idle wheels.
4. Please make sure that the saw blade is properly clamped by the left and right inserts.
5. Please check the wire brush for proper contact with the saw blade. Replace the wire brush if it is worn out.

### After ending a day's work

Please remove saw chips and clean the machine with discharging the cutting fluid when work has been completed.



Do not discharge cutting fluid while the saw blade is operating because it will cause severe injury on operator's hand.



Be sure the saw blade is fully stop, it will be performed after working inspection.

### Every 2 weeks

Please apply grease to the following points:

1. Idle wheel
2. Drive wheel
3. Blade tension device

#### Recommended Grease:

- Shell Alvania EP Grease 2
- Mobil Mobilplex 48

### First 600hrs for new machine,then every 1200hrs

Replace the transmission oil after operating for first 600hrs for new machine,then every 1200hrs

#### Recommended gear oil

- Shell Omala oil HD220
- Mobil gear 630

#### Recommended hydraulic oil

- ShellTellus 32
- Mobil DTE Oil Light Hydraulic 28

## Every six months

1. Clean the filter of the cutting fluid.
2. Replace the transmission oil for every half of a year (or 1200 hours).  
Check the sight gauge to ascertain the transmission level.

### Recommended TRANSMISSION OIL

- Omala oil HD220
- Mobil comp 632 600W Cylinder oil

3. Replace the hydraulic oil.

### Recommended HYDRAULIC OIL

- Shell Tellus 27
- Mobil DTE OIL light Hydraulic 28

## STORAGE CONDITIONS

Generally, this machine will be stored on the following conditions in future:

- (1) Turn off the power.
- (2) Ambient temperature: 5°C ~ 40°C
- (3) Relative humidity: 30%~95% (without condensation)
- (4) Atmosphere: use a plastic canvas to cover machine to avoid excessive dust, acid fume, corrosive gases and salt.
- (5) Avoid exposing to direct sunlight or heat rays which can change the environmental temperature.
- (6) Avoid exposing to abnormal vibration.
- (7) Must be connected to earth.

## TERMINATING THE USE OF THE MACHINE

Waste disposal:

When your machine can not work anymore, you should leak out the oil from machine body. Please storage the oil in safe place with bottom. Ask a environment specialist to handle the oil. It can avoid soil pollution. The oil list in machine:

- Hydraulic oil
- Cutting fluid
- Drive wheel gear oil

## OIL RECOMMENDATION FOR MAINTENANCE

Item	Method	Revolution	Suggest oil
Dovetail guide	Keep grease covered. Antirust.	Daily	Shell R2
Roller bearing	Sweep clean and oil with lubricant.	Daily	SEA #10
Bed roller / surface	Sweep clean and oil with lubricant.	Daily	SEA #10
Nipples of bearing	Use grease gun, but not excess.	Monthly	Shell R2
Blade tension device	Use grease gun, but not excess.	Monthly	Shell Alvania EP Grease 2, Mobil Mobilplex 48
Reducer	Inspect once a week. Change oil of 600 hours of using. Change it every year.	Regularly	Omala oil HD220 Mobil Gear 630
Hydraulic system	Inspect half a year. Change oil every year.	Regularly	Shell Tellus 32 Mobil DTE oil Light Hydraulic 24
Bearing	Inserts	Oil with lubricant, but not excess.	Daily
	Band wheel	Oil with lubricant, but not excess.	Weekly
	Cylinder	Oil with lubricant, but not excess.	6 Monthly
	Wire brush	Oil with lubricant, but not excess.	6 Monthly



1. Turn off the stop circuit breaker switch before servicing the machine.
2. Then post a sign to inform people that the machine is under maintenance.
3. Drain all of the cutting fluid and oil off and carefully treat them to avoid pollution.

# **TROUBLESHOOTING**

## **INTRODUCTION**

## **PRECAUTIONS**

## **GENERAL TROUBLES & SOLUTIONS**

## **MINOR TROUBLES & SOLUTIONS**

## **MOTOR TROUBLES & SOLUTIONS**

## **BLADE TROUBLES & SOLUTIONS**

## **SAWING PROBLEMS & SOLUTIONS**

## **RE-ADJUSTING THE ROLLER TABLE**

## **INTRODUCTION**

All the machines manufactured by us pass a 48 hours continuously running test before shipping out and we are responsible for the after sales service problems during the warranty period if the machines are used normally. However, there still exist the some unpredictable problems which may disable the machine from operating.

Generally speaking, the system troubles in this machine model can be classified into three types, namely GENERAL TROUBLES, MOTOR TROUBLES and BLADE TROUBLES. Although you may have other troubles which can not be recognized in advance, such as malfunctions due to the limited life-span of mechanical, electric or hydraulic parts of the machine.

We have accumulated enough experiences and technical data to handle all of the regular system troubles. Meanwhile, our engineering department had been continuously improving the machines to prevent all possible troubles.

It is hoped that you will give us your maintenance experience and ideas so that both sides can achieve the best performance.

## PRECAUTIONS

When an abnormality occurs in the machine during operation, you can do it yourself safely. If you have to stop machine motion immediately for parts exchanging, you should do so according to the following procedures:

- Press HYDRAULIC MOTOR OFF button or EMERGENCY STOP button.
- Open the electrical enclosure door.
- Turn off breaker.



**BEFORE ANY ADJUSTMENT OR MAINTENANCE OF THE MACHINE, PLEASE MAKE SURE TO TURN OFF THE MACHINE AND DISCONNECT THE POWER SUPPLY.**

## GENERAL TROUBLES AND SOLUTIONS



**DISCONNECT POWER CORD TO MOTOR BEFORE ATTEMPTING ANY REPAIR OR INSPECTION.**

TROUBLE	PROBABLE CAUSE	SUGGESTED REMEDY
Motor stalls	Excessive belt tension	Adjust belt tension so that belt does not slip on drive pulley while cutting ( 1/2" Min. deflection of belt under moderate pressure.)
	Excessive head pressure	Reduce head pressure. Refer to Operating Instructions "Adjusting Feed".
	Excessive blade speed	Refer to Operating Instructions "Speed Selection".
	Improper blade selection	Refer to Operating Instructions "Blade Selection".
Cannot make square cut	Dull blade	Replace blade.
	Guide rollers not adjusted properly	Refer to Adjustments.
	Rear vise jaw not adjusted properly	Set fixed vise jaw 90° to blade.
	Excessive head pressure	Reduce head pressure. Refer to operating instructions "Adjusting Feed."
Increased cutting time	Dull blade	Replace blade
	Insufficient head pressure	Increase head pressure. Refer to Operating Instructions "Adjusting Feed."
	Reduce blade speed	Refer to Operating Instructions "Speed Selection."
Will not cut	Motor running in wrong direction	Reverse rotation of motor. (Motor rotation C.C.W. pulley end.)
	Blade teeth pointing in wrong direction	Remove blade, turn blade inside out. Re-install blade. (Teeth must point in direction of travel. )
	Hardened material	Use special alloy blades. (Consult your industrial distributor for recommendation on type of blade required.)



## MINOR TROUBLES & SOLUTIONS

TROUBLE	PROBABLE CAUSE	SUGGESTED REMEDY
Saw blade motor does not run even though blade drive button is pressed.	Overload relay activated	Reset
	Saw blade is not at forward limit position.	Press SAW FRAME FORWARD button

## MOTOR TROUBLES & SOLUTIONS

TROUBLE	PROBABLE CAUSE	SUGGESTED REMEDY
Motor will not start	Magnetic switch open, or protector open.	Reset protector by pushing red button (inside electric box.)
	Low voltage	Check power line for proper voltage.
	Open circuit in motor or loose connections.	Inspect all lead terminations on motor for loose or open connections.
Motor will not start, fuse or circuit breakers "blow".	Short circuit in line, cord or plug.	Inspect line, cord and plug for damaged insulation and shorted wire.
	Short circuit in motor or loose connections	Inspect all lead terminations on motor for loose or shorted terminals or worn insulation on wires.
	Incorrect fuses or circuit breakers in power line.	Install correct fuses or circuit breakers.
Motor fail to develop full power. (Power output of motor decreases rapidly with decrease in voltage at motor terminals.)	Power line overloaded with lights, appliances and other motors.	Reduce the load on the power line.
	Undersize wires or circuit too long.	Increase wire sizes, or reduce length of wiring
	General overloading of power company's facilities.	Request a voltage check from the power company
Motor overheat	Motor overloaded.	Reduce load on motor
	Air circulation through the motor restricted.	Clean out motor to provide normal air circulation through motor.
Motor stalls (Resulting in blown fuses or tripped circuit breakers)	Short circuit in motor or loose connections.	Inspect terminals in motor for loose or shorted terminals or worn insulation on lead wires.
	Low voltage	Correct the low line voltage conditions.
	Incorrect fuses or circuit breakers in power line.	Install correct fuses circuit breakers.
	Motor overloaded	Reduce motor load.
Frequent opening of fuses or circuit breakers.	Motor overloaded	Reduce motor load
	Incorrect fuses or circuit breakers.	Install correct fuses or circuit breakers.

## BLADE TROUBLES AND SOLUTIONS



**DISCONNECT POWER CORD TO MOTOR BEFORE ATTEMPTING ANY REPAIR OR INSPECTION.**

TROUBLE	PROBABLE CAUSE	SUGGESTED REMEDY
Teeth strippage	Too few teeth per inch	Use finer tooth blade
	Loading of gullets	Use coarse tooth blade or cutting lubricant.
	Excessive feed	Decrease feed
	Work not secured in vise	Clamp material securely
Blade breakage	Teeth too coarse	Use a finer tooth blade
	Misalignment of guides	Adjust saw guides
	Dry cutting	Use cutting lubricant
	Excessive speed	Lower speed. See Operating Instructions "Speed selection."
	Excessive speed	Reduce feed pressure. Refer to Operating Instructions "Adjusting Feed."
	Excessive tension	Tension blade to prevent slippage on drive wheel while cutting.
Blade line Run-out or Run-in	Wheels out of line	Adjust wheels
	Guides out of line	For a straight and true cut, realign guides, check bearings for wear.
	Excessive pressure	Conservative pressure assures long blade life and clean straight cuts.
	Support of blade insufficient	Move saw guides as close to work as possible.
	Material not properly secured in vise	Clamp material in vise, level and securely.
Blade twisting	Blade tension improper	Loosen or tighten tension on blade.
	Blade not in line with guide bearings	Check bearings for wear and alignment.
	Excessive blade pressure	Decrease pressure and blade tension
Premature tooth wear	Blade binding in cut	Decrease feed pressure
	Dry cutting	Use lubricant on all materials, except cast iron
	Blade too coarse	Use finer tooth blade
	Not enough feed	Increase feed so that blade does not ride in cut
	Excessive speed	Decrease speed

## SAWING PROBLEMS AND SOLUTIONS

Other than this manual, the manufacturer also provides some related technical documents listed as follows:

### Sawing Problems and Solutions

					Vibration during cutting	Failure to cut	Short life of saw blade	Curved cutting	Broken blade		
✓	✓	✓	✓	✓						Use of blade with incorrect pitch	Use blade with correct pitch suited to workpiece width
✓	✓	✓	✓	✓						Failure to break-in saw blade	Perform break-in operation
✓	✓	✓								Excessive saw blade speed	Reduce speed
			✓	✓						Insufficient saw blade speed	Increase speed
✓		✓	✓	✓						Excessive saw head descending speed	Reduce speed
✓		✓	✓							Insufficient saw head descending speed	Increase speed
		✓	✓							Insufficient saw blade tension	Increase tension
✓		✓	✓	✓						Wire brush improperly positioned	Relocate
✓		✓	✓							Blade improperly clamped by insert	Check and correct
✓	✓	✓	✓	✓						Improperly clamped workpiece	Check and correct
	✓	✓	✓							Excessively hard material surface	Soften material surface
		✓	✓	✓						Excessive cutting rate	Reduce cutting rate
	✓	✓								Non-annealed workpiece	Replace with suitable workpiece
✓		✓	✓	✓						Insufficient or lean cutting fluid	Add fluid or replace
✓		✓	✓	✓						Vibration near machine	Relocate machine
		✓	✓							Non-water soluble cutting fluid used	Replace
✓		✓	✓							Air in cylinder	Bleed air
✓		✓		✓						Broken back-up roller	Replace
✓	✓	✓	✓	✓						Use of non-specified saw blade	Replace
✓	✓	✓	✓	✓						Fluctuation of line voltage	Stabilize
✓		✓	✓							Adjustable blade guide too far from workpiece	Bring blade guide close to workpiece
✓		✓	✓	✓						Loose blade guide	Tighten
		✓		✓						Blue or purple saw chips	Reduce cutting rate
✓		✓		✓						Accumulation of chips at inserts	Clean
	✓									Reverse positioning of blade on machine	Reinstall
✓		✓	✓							Workpieces are not bundled properly	Re-bundle
✓		✓		✓						Back edge of blade touching wheel flange	Adjust wheel to obtain clearance
✓	✓	✓								Workpiece of insufficient diameter	Use other machine, suited for diameter of workpiece
	✓	✓	✓							Saw blade teeth worn	Replace

## **SOLUTIONS TO SAWING PROBLEMS**

### Table Of Contents

#1. Heavy Even Wear On Tips and Corners Of Teeth	#11. Uneven Wear Or Scoring On The Sides Of Band
#2. Wear On Both Sides Of Teeth	#12. Heavy Wear And/Or Swagging On Back Edge
#3. Wear On One Side Of Teeth	#13. Butt Weld Breakage
#4. Chipped Or Broken Teeth	#14. Heavy Wear In Only The Smallest Gullets
#5. Body Breakage Or Cracks From Back Edge	#15. Body Breaking – Fracture Traveling In An Angular Direction
#6. Tooth Strippage	#16. Body Breakage Or Cracks From Gullets
#7. Chips Welded To Tooth Tips	#17. Band is Twisted Into A Figure "8" Configuration
#8. Gullets Loading Up With Material	#18. Used Band Is "Long" On The Tooth Edge
#9. Discolored Tips Of Teeth Due To Excessive Frictional Heat	#19. Used Band Is "Short" On The Tooth Edge
#10. Heavy Wear On Both Sides Of Band	#20. Broken Band Shows A Twist In Band Length.

### **#1. Heavy Even Wear On Tips and Corners Of Teeth**

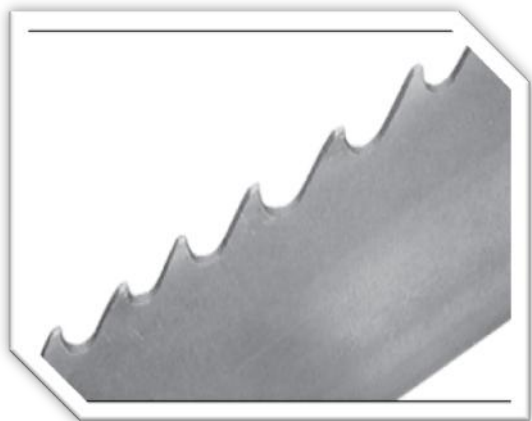

#### **Probable Cause :**

- A.** Improper break-in procedure.
- B.** Excessive band speed for the type of material being cut. This generates a high tooth tip temperature resulting in accelerated tooth wear.
- C.** Low feed rate causes teeth to rub instead of penetrate. This is most common on work hardened materials such as stainless and toolsteels.
- D.** Hard materials being cut such as "Flame Cut Edge" or abrasive materials such as " Fiber Reinforced Composites".
- E.** Insufficient sawing fluid due to inadequate supply, improper ratio, and/or improper application

## #2. Wear On Both Sides Of Teeth

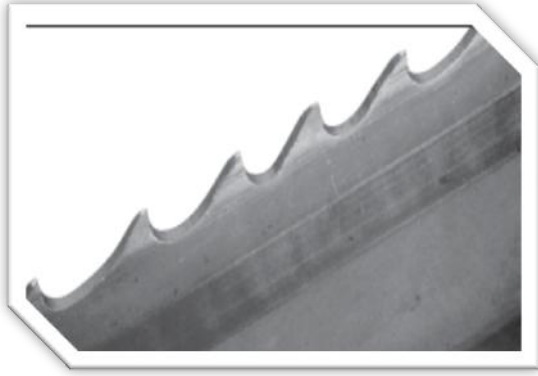

### Probable Cause :

- A. Broken, worn or missing back-up guides allowing teeth to contact side guides.
- B. Improper side guides for band width.
- C. Backing the band out of an incomplete cut.

## #3. Wear On One Side Of Teeth

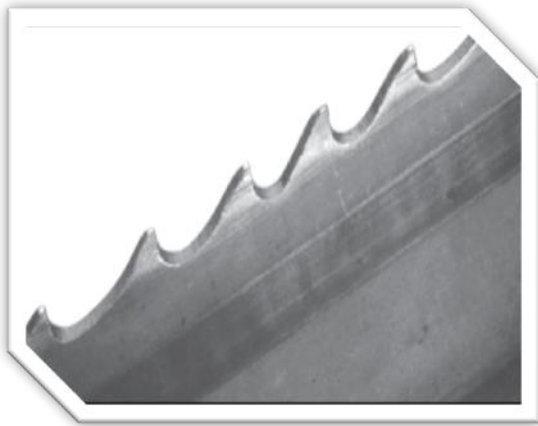

### Probable Cause :

- A. Worn wheel flange, allowing side of teeth to contact wheel surface or improper tracking on flangeless wheel.
- B. Loose or improperly positioned side guides.
- C. Blade not perpendicular to cut.
- D. Blade rubbing against cut surface on return stroke of machine head.
- E. The teeth rubbing against a part of machine such as chip brush assembly, guards, etc.

## #4. Chipped Or Broken Teeth

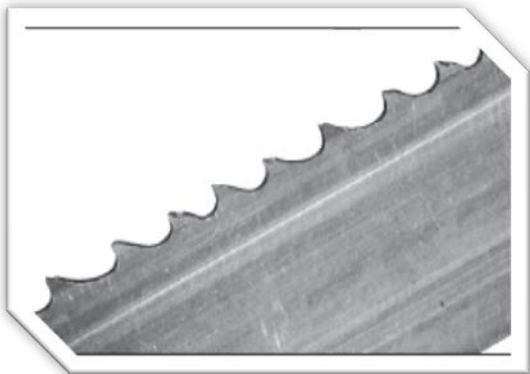

### Probable Cause :

- A. Improper break-in procedure.
- B. Improper blade selection for application.
- C. Handling damage due to improper opening of folded band.
- D. Improper positioning or clamping of material.
- E. Excessive feeding rate or feed pressure.
- F. Hitting hard spots or hard scale in material

## #5. Body Breakage Or Cracks From Back Edge

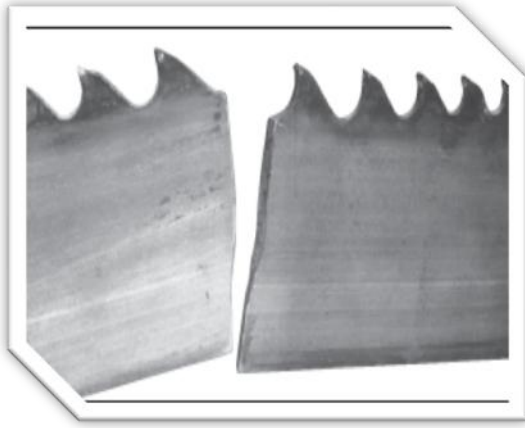

### Probable Cause :

- A. Excessive back-up guide "preload" will cause back edge to work harden which results in cracking.
- B. Excessive feed rate.
- C. Improper band tracking – back edge rubbing heavy on wheel flange.
- D. Worn or defective back-up guides.
- E. Improper band tension.
- F. Notches in back edge from handling damage

## #6. Tooth Strippage



### Probable Cause :

- A. Improper or lack of break-in procedure.
- B. Worn, missing or improperly positioned chip brush.
- C. Excessive feeding rate or feed pressure.
- D. Movement or vibration of material being cut.
- E. Improper tooth pitch for cross sectional size of material being cut.
- F. Improper positioning of material being cut.
- G. Insufficient sawing fluid due to inadequate supply, improper ratio and/or improper application.
- H. Hard spots in material being cut.
- I. Band speed too slow for grade of material being cut.

## #7. Chips Welded To Tooth Tips

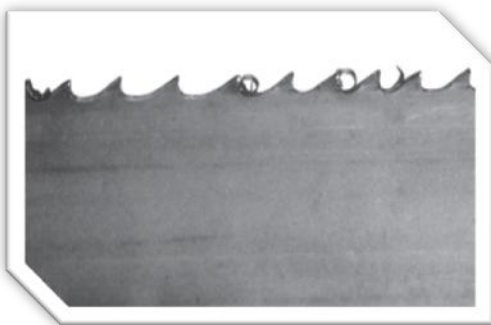

### Probable Cause :

- A. Insufficient sawing fluid due to inadequate supply, improper ratio and/or improper application.
- B. Worn, missing or improperly positioned chip brush.
- C. Improper band speed.
- D. Improper feeding rate.

## #8. Gullets Loading Up With Material

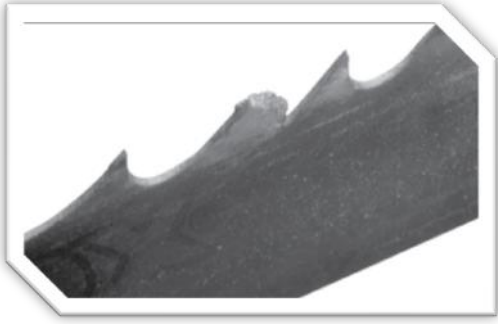

### Probable Cause :

- A. Too fine of a tooth pitch – insufficient gullet capacity.
- B. Excessive feeding rate producing too large of a chip.
- C. Worn, missing or improperly positioned chip brush.
- D. Insufficient sawing fluid due to inadequate supply, improper ratio and/or improper application.

## #9. Discolored Tips Of Teeth Due To Excessive Frictional Heat

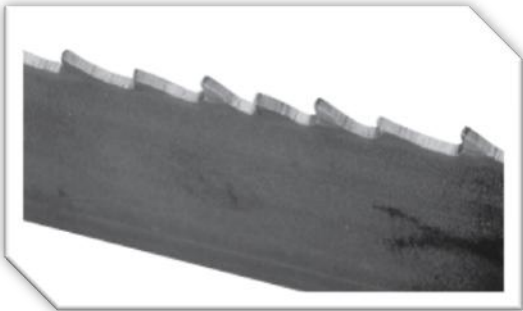

### Probable Cause :

- A. Insufficient sawing fluid due to inadequate supply, improper ratio and/or improper application.
- B. Excessive band speed.
- C. Improper feeding rate.
- D. Band installed backwards.

## 10. Heavy Wear On Both Sides Of Band

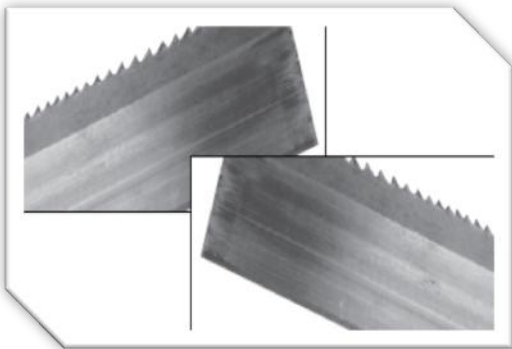

### Probable Cause :

- A. Chipped or broken side guides.
- B. Side guide adjustment may be too tight.
- C. Insufficient flow of sawing fluid through the side guides.
- D. Insufficient sawing fluid due to inadequate supply, improper ratio and/or improper application.

## #11. Uneven Wear Or Scoring On The Sides Of Band

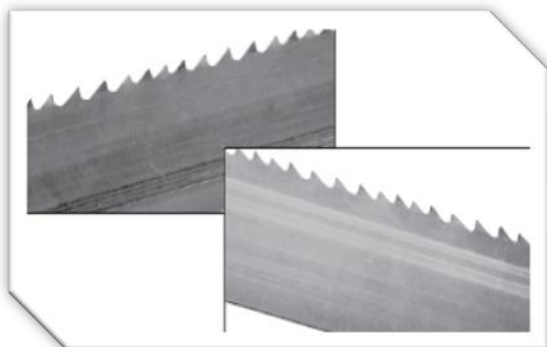

### Probable Cause :

- A. Loose side guides.
- B. Chipped, worn or defective side guides.
- C. Band is rubbing on part of the machine.
- D. Guide arms spread to maximum capacity.
- E. Accumulation of chips in side guides.

### #12. Heavy Wear And/Or Swagging On Back Edge



**Probable Cause :**

- A. Excessive feed rate.
- B. Excessive back-up guide "preload".
- C. Improper band tracking – back edge rubbing heavy on wheel flange.
- D. Worn or defective back-up guides.

### #13. Butt Weld Breakage



**Probable Cause :**

- A. Any of the factors that cause body breaks can also cause butt weld breaks.
- (See Observations #5, #15 and #16)**

### #14. Heavy Wear In Only The Smallest Gullets



**Probable Cause :**

- A. Excessive feeding rate.
- B. Too slow of band speed.
- C. Using too fine of a tooth pitch for the size of material being cut.

### #15. Body Breaking – Fracture Traveling In An Angular Direction



**Probable Cause :**

- A. An excessive twist type of stress existed.
- B. Guide arms spread to capacity causing excessive twist from band wheel to guides.
- C. Guide arms spread too wide while cutting small cross sections.
- D. Excessive back-up guide "preload".



## #16. Body Breakage Or Cracks From Gullets

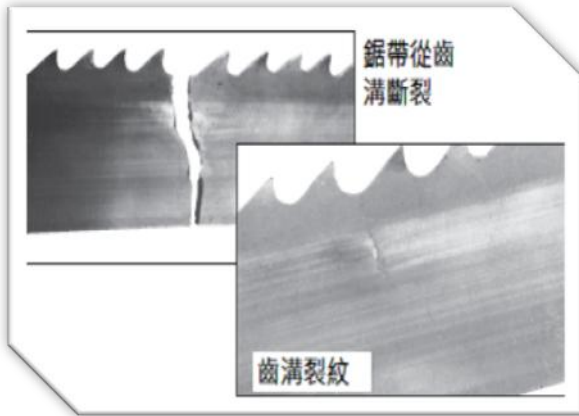

### Probable Cause :

- A. Excessive back-up guide "preload".
- B. Improper band tension.
- C. Guide arms spread to maximum capacity.
- D. Improper beam bar alignment.
- E. Side guide adjustment is too tight.
- F. Excessively worn teeth.

## #17. Band is Twisted Into A Figure "8" Configuration

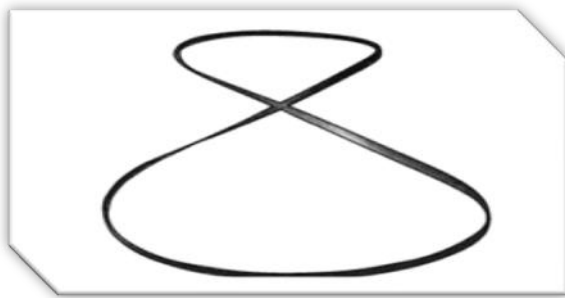

### Probable Cause :

- A. Excessive band tension.
- B. Any of the band conditions which cause the band to be long (#18) or short (#19) on tooth edge.
- C. Cutting a tight radius.

## #18. Used Band Is "Long" On The Tooth Edge



### Probable Cause :

- A. Side guides are too tight – rubbing near gullets.
- B. Excessive "preload" – band riding heavily against back-up guides.
- C. Worn band wheels causing uneven tension.
- D. Excessive feeding rate.
- E. Guide arms are spread to maximum capacity.
- F. Improper band tracking – back edge rubbing heavy on wheel flange.

## #19. Used Band Is "Short" On The Tooth Edge



### Probable Cause :

- A. Side guides are too tight – rubbing near back edge.
- B. Worn band wheels causing uneven tension.
- C. Guide arms are spread too far apart.
- D. Excessive feeding rate.

## #20. Broken Band Shows A Twist In Band Length

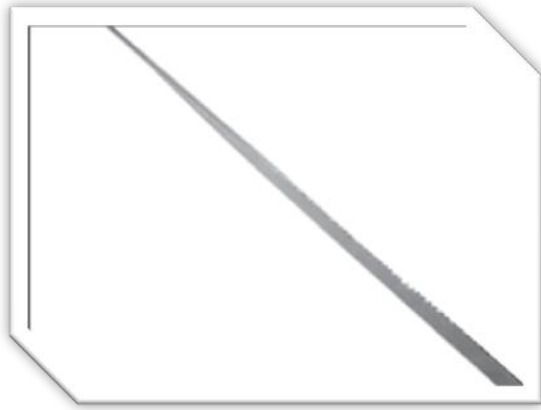

### Probable Cause :

- A. Excessive band tension
- B. Any of the band conditions which cause the band to be long (#18) or short (#19) on tooth edge.
- C. Cutting a tight radius.

## RE-ADJUSTING THE ROLLER TABLE

If the feeding table suffers the huge stroke and the alignment is effected, follow the below procedure to adjust.

### TOOL, measuring

Measurement, Horizontal balance

### Procedure

1. Screw or loosen the adjusting bolt to attain the horizontal balance (leveling) between the roller table and the machine frame.
2. Ensure that the machine frame is not struck by the loaded material on the feeding table.
3. Check the leveling by the measuring tool.
4. After finished the adjusting, fix the roller table.



**If the feeding table and the machine frame are not positioned under the horizontal balance, the loaded material may be going up gradually and affect the cutting effect.**

# PARTS

## SPARE PARTS RECOMMENDATIONS

### PART LIST

## SPARE PARTS RECOMMENDATIONS

The following table lists the common spare parts we suggest you purchase in advance:

Part Name	Part Name
Saw blade	Coolant tank filter
Wire brush	Steel plates
Carbide inserts	Rollers
Bearings	Belt
Hydraulic tank leak-proof gasket	Duster seal
Rubber washer	Snap ring
Oil seal	O-ring



# Warranty

## Warranty

New machines are warranted to be free from defects in workmanship and material for a period of one (1) year from the date of shipment by Seller. The warranty period is based on normal usage of two thousand eighty hours (2080) per year and is reduced proportionately for any excess usage. Products, which under normal operating conditions in Buyer's plant are defective in workmanship or material, will be repaired or replaced at the option of Seller.

This warranty does not cover shipping freight charges for either the return of the defective part or for the shipping of the replacement or repaired part.

Seller will have no obligation to repair or replace perishable parts, or materials or parts damaged by misuse, negligence or failure of Buyer to provide appropriate maintenance and service as stated in the operator's manual or industry standard and normally acceptable practices.

This warranty does not apply if the machine has been altered or modified without our prior written consent.

In the case of components or units purchased by Seller including work holding devices, tool holders, motors and controls, the warranty shall not exceed that received by Seller from the supplier of such components or units.

Seller will not assume responsibility for products or components returned to Seller without prior consent or for unauthorized repairs to its products, even though defective.

**Electrical Equipment:** The warranty available for all electrical components to the Buyer will be voided if the voltage supplied to the machine is found to be outside the stated voltage of the machine by +/- 10% and/or grounded at machine.

**Accessories Supplied with Manufacturer's Equipment:** The warranties available to the Buyer are those extended by the accessory manufacturer, if any, to the extent they are in force and effect. The ACCESSORY MANUFACTURER'S WARRANTY, if any, is exclusive and is in lieu of all other warranties whether written, oral or implied.





# COSEN SAWS

Vertical Plate Saws  
Horizontal Billet Saws  
NC/CNC Band Saws  
Structural Miter-Cutting Saws  
Automatic Band Saws

Visit our website at  
**[www.cosen.com](http://www.cosen.com)**