



SH-250R

Semi-Automatic
Hinge-Type Horizontal Bandsaw

(Non-CE & CE Models)

Instruction Manual

The Pinnacle of Cutting Performance

Cosen Mechatronics Co., Ltd.

FROM THE MANUFACTURER

Thank you for your purchase of COSEN's bandsaw machine and your trust in the COSEN brand.

We are excited to have you as our valued customer and look forward as much as you do to the accelerated productivity, long-lasting endurance and superb cost-effectiveness this machine is about to bring to you.

To ensure you are fully utilizing our machine and being advantaged in every possible way, please do take your time and read through this instruction manual.

Any comment or suggestion in making our service better, please do not hesitate to let us know. Thank you again!

NOTE:



- Read this instruction manual carefully to familiarize yourself with the installation, operation and maintenance of your COSEN bandsaw machine.
- Operate the machine following the procedures described in the manual to prevent personal injuries or machine damage.
- Keep this manual handy and refer to it whenever you are uncertain of how to perform any of the procedures.



- For technical support or parts purchase, please contact your nearest COSEN representative or our service center:

For US, Mexico, and Canada:
email: info@cosensaws.com
phone: +1-704-943-1030
toll free: +1-877-SAWING1
fax: +1-704-943-1031

For Europe:
email: europa@cosensaws.com
phone: +31-77-7600280
fax: +31-77-7600288

For China:
email: service@cosensaws.cn
phone: +86-152-50127815

For Taiwan and other countries:
email: info@cosen.com
phone: +886-3-5332143
fax: +886-3-5348324

Instruction Manual: SH-250R
Semi-Automatic Hinge-Type Horizontal Bandsaw
(Non-CE & CE models)
Ver.2 2016/3/30

© 2014 by COSEN MECHATRONICS CO., LTD.

No part of this publication may be photocopied or otherwise reproduced without the prior written permission of COSEN

Printed in Taiwan

Safety rules

- Make sure your work area is cleared of uninvited people and obstacles every time before you start operating the machine.
- Never wear gloves or loose clothing when operating the machine. It may lead to serious injury if they are caught in the running machine. Wrap or cover long hair.
- Use a water-soluble cutting fluid on this machine. Oil-based cutting fluids may emit smoke or catch fire, depending on how they are used.
- Never cut carbon or any other material that may produce and disperse explosive dust. It is possible that sparks from motors and other machine parts will ignite and explode the air-borne dust.
- Make sure any use of fire is prohibited in the shop and install a fire extinguisher or other fire control device near the machine when cutting titanium, magnesium, or any other material that produces flammable chips. Never leave the machine unattended when cutting flammable materials.
- Never adjust the wire brush or remove chips while the saw blade is still running. It is extremely dangerous if hands or clothing are caught by the running blade.
- Never touch the running saw blade with gloves or not. It is dangerous if your hands, clothing or gloves are caught by the running blade.
- Stop the saw blade before you clean the machine. It is dangerous if hands or clothing are caught by the running blade.
- Never start the saw blade unless the workpiece has been clamped firmly. If the workpiece is not securely clamped, it will be forced out of the vise during cutting.
- Take preventive measures when cutting thin or short pieces from the work to keep them from falling. It is dangerous if the cut pieces fall.
- Use roller tables at the front and rear sides of the machine when cutting long work. It is dangerous if the work piece falls off the machine.
- Never step or stand on the roller table. Your foot may slip or trip on the rollers and you will fall.
- Turn off the shop circuit breaker switch before performing maintenance on the machine. Post a sign indicating the machine is under maintenance.

Table of Contents

Section 1 – Safety Information	1-1
Safety Instructions	1-1
Safeguard Devices	1-3
Emergency Stop	1-4
<i>Illustration: Emergency Stop</i>	1-5
Safety Labels	1-6
<i>Illustration: Safety Labels</i>	1-9
Hearing Protection	1-10
CE Compliance	1-10
Risk Assessment	1-10
Section 2 – General Information	2-1
Specification	2-2
Machine Parts Identification	2-3
Floor Plan	2-4
Section 3 – Moving & Installation	3-1
Location & Environment	3-1
Unpacking & Inspecting	3-2
Lifting	3-3
<i>Illustration: Lifting Points</i>	3-5
Removing Shipping Bracket	3-6
Cleaning	3-6
Installing	3-6
Supplying Hydraulic Oil	3-6
Supplying Coolant	3-7
Connecting Electric Power	3-7
Leveling	3-8
Anchoring the Machine	3-9
Installing Roller Table (Optional)	3-9
Installing Fire Control Device	3-9
Relocating	3-9
Section 4 – Operating Instructions	4-1
Safety Precautions	4-2
Before Operating	4-3
Control Panel	4-4
Control Panel	4-4

Table of Contents

Control Buttons	4-5
Standard Accessories	4-6
Optional Accessories	4-7
Unrolling & Installing the Blade	4-8
Adjusting Blade Speed	4-10
Adjusting Saw Arm	4-11
Adjusting Coolant Flow	4-11
Adjusting Vise	4-12
Angle Cutting	4-12
Quick Adjusting Movable Vise Position	4-13
Installing Material Stop Bracket	4-13
Adjusting Wire Brush	4-14
Adjusting Horizontal Stop Spring Cushion	4-14
Test-Running the Machine	4-15
Breaking-In the Blade	4-15
Cutting Operation	4-16
Terminating a Cutting Operation	4-16
Section 5 – Electrical System	5-1
Electrical Circuit Diagrams	5-1
Section 6 – Hydraulic System	6-1
Hydraulic Circuit Diagrams	6-1
Section 7 – Bandsaw Cutting: A Practical Guide	7-1
Introduction	7-1
Saw Blade Selection	7-1
Some Sawing Practices	7-4
Saw Pitch Selection	7-4
Material Size and Saw Pitch	7-4
Section 8 – Maintenance & Service	8-1
Introduction	8-1
Basic Maintenance	8-1
Maintenance Schedule	8-1
Before Beginning a Day’s Work	8-2
After Ending a Day’s Work	8-2
Every Month	8-2
Every Three Months	8-2
Every Six Months	8-3

Table of Contents

Storage Conditions	8-3
Terminating the Use of Machine	8-3
Oil Recommendation for Maintenance	8-4
Section 9 – Troubleshooting	9-1
Introduction	9-1
Precautions	9-2
General Troubles & Solutions	9-2
Minor Troubles & Solutions	9-3
Motor Troubles & Solutions	9-3
Blade Troubles & Solutions	9-4
Sawing Problems & Solutions	9-5
Re-Adjusting the Roller Table	9-6
Section 10 – Warranty	10-1
Warranty	10-1
Section 11 – Parts	11-1
Spare Parts Recommendations	11-1
Parts List	11-2

SAFETY INFORMATION

SAFETY INSTRUCTIONS

SAFEGUARD DEVICES

EMERGENCY STOP

SAFETY LABELS

HEARING PROTECTION

CE COMPLIANCE

RISK ASSESSMENT

Safety is a combination of a well-designed machine, operator's knowledge about the machine and alertness at all times. COSEN's band machine has incorporated many safety measures during the design process and used protective devices to prevent personal injuries and potential risks. Warning labels also serve as a reminder to the operator.

Throughout this manual, you will also see various safety-related symbols indicating important information that you should take note of prior to use of the machine or part of its functions. These important safety instructions do not cover all possible situations that might occur. It is your responsibility to take caution and follow procedures stated in this manual when installing, maintaining and operating your machine. Cosen will not be liable for damages resulting from improper use.

SAFETY INSTRUCTIONS

What the icons and signs in this user manual mean:



This icon marks **DANGER**; hazards or unsafe practices that may result in **severe personal injury or death**.



This icon marks **WARNING**; hazards or unsafe practices that may result in **personal injury or damage to the machine**.



This icon marks **CAUTION**; information that should be read before use to prevent **damage to the machine**.



Supplementary information to the procedures described in this manual.



Call your local agent or our service center for help.



This manual has important safety information. Read through it carefully before operating this machine to prevent personal injury or machine damage. Learn the operation, limitation and the specific potential hazards peculiar to this band saw.



Do not operate this machine unless it is completely assembled.



Make sure the power switch is off before plugging in power cord.



Disconnect the power cord before making adjustment, maintenance or blade changes.



Keep all guards and shields in place before installing or starting up the machine.



Wear proper apparel during operation and when servicing the machine.



Keep unauthorized personnel away.



Do not reach over or stand on any part of the machine.



Never hold the material by hand for cutting. Always use the vise and make sure the material is clamped securely before cutting.



It is dangerous to operate the machine when the floor is slippery. Keep the floor clean and dry. Check for ice, moisture, or grease before entering.



Do not use the machine to cut explosive material or high pressure vessels as it will generate great amount of heat during the sawing process and may ignite an explosion.



Keep the work environment safe. Do not use band saw in a damp or wet location.



Never operate while under the influence of drugs, alcohol or medication.



All users must read it before performing any activity on the machine, such as replacing the saw band or doing regular maintenance.



Some personal protective equipment is required for the safe use of the machine, e.g. protection goggles.



Keep blade protection cover and wheel covers in place and in working order.



Use recommended accessories. Improper accessories may be hazardous.



Keep your work area well illuminated at minimum 500 lumen.



Keep your work area clean. Cluttered and slippery floors invite accidents.



Remove adjusting keys, wrenches or any loose parts or items from the machine before turning on power.



Check for damaged parts. Before continuing using the machine, the damaged part should be checked and replaced.



Moving parts should be kept in proper alignment and connection with the machine. Check for breakage, mounting and any other conditions that may affect its operation. Any damaged part or guard should be properly repaired or replaced.



When a workpiece is too long or heavy, make sure it is supported with a roller table (recommended).



Always remember to switch off the machine when the work is completed.



Use a sharp saw blade and keep the machine in its best and safest performance by following a periodical maintenance schedule.



Do not force the band saw beyond its intended use. It is safer to operate with the cutting rate for which it was designed.

SAFEGUARD DEVICES

The safeguard devices incorporated in this machine include the following two main parts:

1. Protection covers & guards
2. Safety-related switches

Protection Covers & Guards

1. Idle wheel housing cover
2. Drive wheel housing cover
3. Gear reducer cover
4. Wire brush belt cover
5. Blade guard cover (left & right)



The protection devices should always be mounted on the machine whenever the machine is running.



Do not remove any of these safeguard devices under any circumstances except when servicing the machine. Even skilled service technicians should still take cautions when performing repairs or service on the machine with any of these protectors removed. It is the responsibility of the user to make sure all these elements are not lost and damaged.



Take note of the following main moving parts on the machine prior to and during machine operation:

- Saw bow assembly
- Drive and idle wheels
- Blade guide arm
- Saw blade guide rollers
- Quick approach device
- Wire brush
- Chip conveyor (optional)
- Workpiece clamping vises
- Shuttle vises and workbed rollers
- Top clamps (optional)
- Gear reducer

Safety Related Switches

To protect the operator, the following safety related switches on the machine are actuated when the machine is in operation.

Wheel motion detector	This is a proximity sensor used to detect the motion of the drive wheel. Once the saw blade is broken or as soon as it starts slipping, the sensor will detect and stop the drive wheel and the machine.
Power switch	Located on the cover of electrical cabinet, the power switch controls the main power of the machine. Up to your company's internal rules, this power switch can be locked with a padlock or a luggage lock to protect the operator and the machine.
Emergency stop button	Located on the control panel, the button when pressed will stop the machine completely.
Vise clamp switch	This switch assures firm clamping of the workpiece. If the workpiece is not clamped properly, the saw blade is not allowed to run.
Wheel cover interlock switches (CE model only)	Located on the two wheel housings, these switches are used to assure that the machine will stop whenever the wheel covers are open. This device is to protect users from being cut by the running saw blades.

Among all these safety switches, some of them are used to protect the users and some of them are used to prevent damage to saw blades, the workpiece and the machine itself, etc. We have taken every precaution to prevent injury or damage and to provide safe and economical operation of the machine.

EMERGENCY STOP

Designed to be easily accessible, the emergency stop button is located on the left bottom corner on the control panel and is made in red color and rubber material. For CE models, supplementary emergency stop button may be available at other area(s) of the machine depending on machine type. Please refer to *Illustration: Emergency Stop*.

When you press the button, the machine will immediately come to a full stop to avoid injury or damage when an accident occurs. The button will be locked when you press it. To unlock it, pull it upward.

You should press it immediately without any hesitation when observing:

- An emergency situation that would cause any injury or damage
- An abnormal situation or problem such as fire, smoke, abnormal noise and etc.

Illustration: Emergency Stop

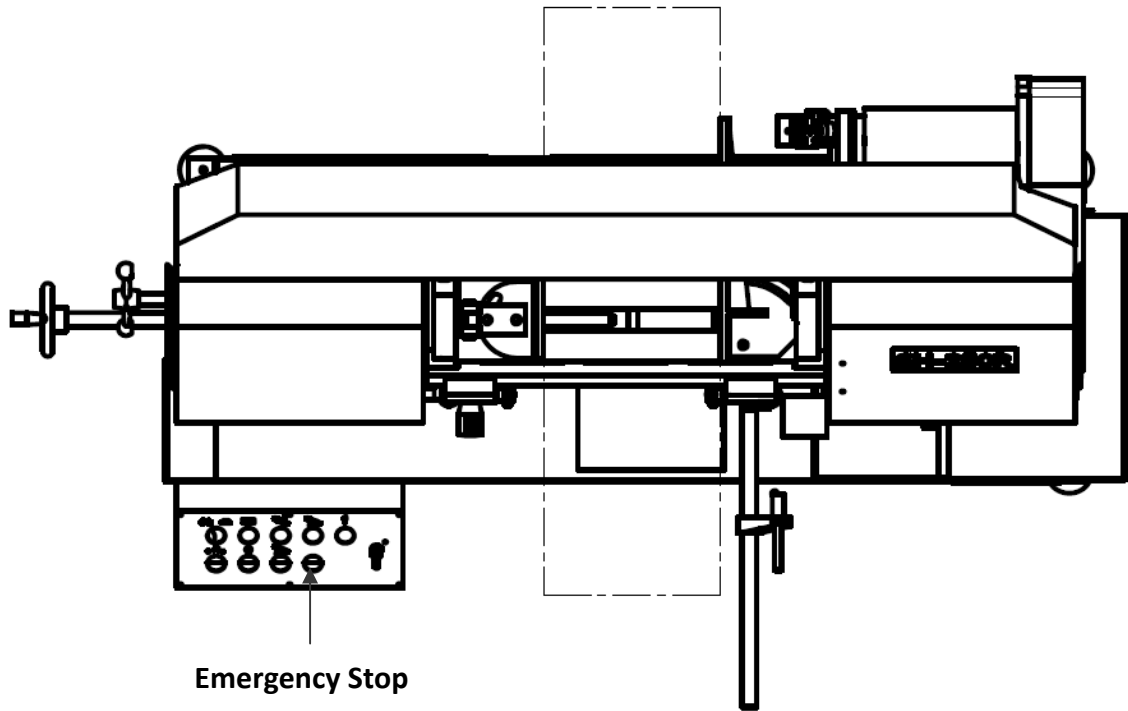

Emergency Stop

Non-CE model

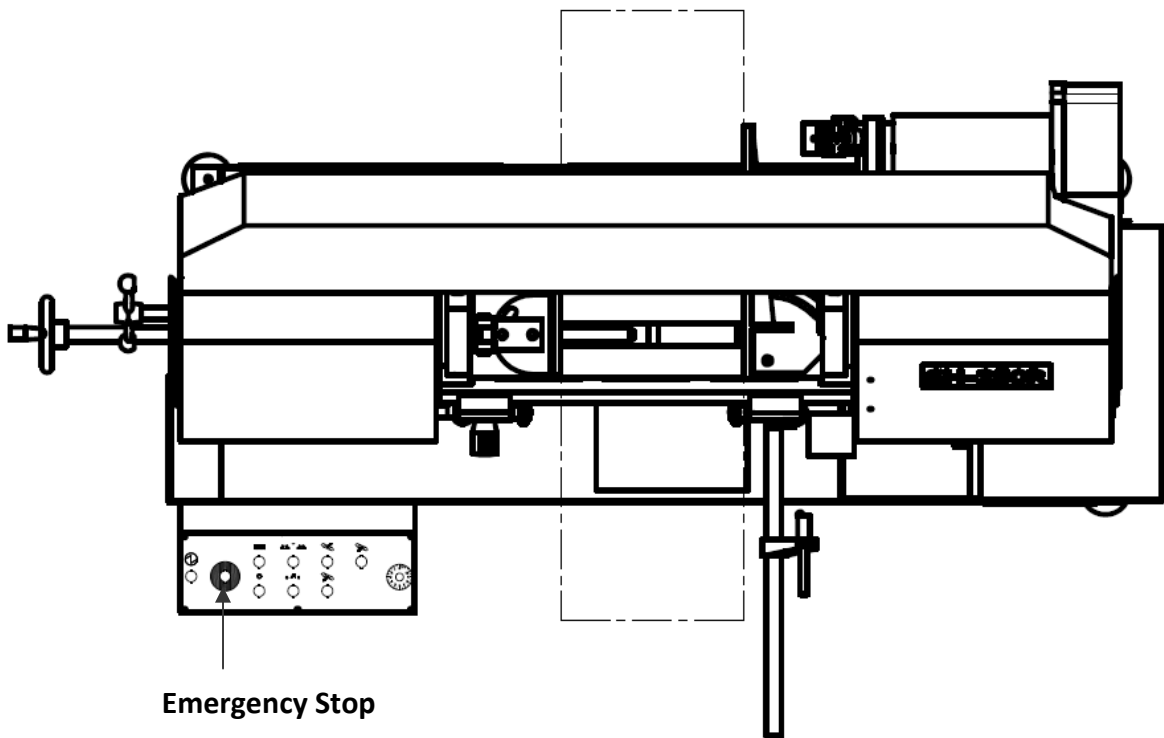

Emergency Stop



CE model

SAFETY LABELS

Safety-related labels mounted on the machine are categorized into the following four categories. Please read through and understand them before operating the machine. Refer to *Illustration: Safety Labels*.





DANGER Labels

A red and white DANGER labels marks s hazards or unsafe practices that will result in severe personal injury or death.

Label	Meaning	Label	Meaning
	<p>Hazardous Voltage</p> <p>TURN POWER OFF before servicing. Failure to following the warning can result in severe injury.</p>		<p>DANGER: Running Blade</p> <p>Blade runs through this area. Keep your hands away from a running blade to avoid severe injury. The arrow indicates direction of the blade.</p>

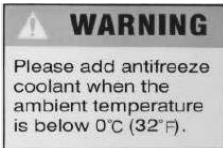

WARNING Labels

An orange and black WARNING label marks hazards or unsafe practices that can result in severe personal injury or damage to the machine.

Label	Meaning	Label	Meaning
	<p>Cutting Hazard</p> <p>KEEP COVER CLOSED while the blade is running. Turn power off before opening cover. Failure to follow the warning can result in severe injury.</p>		<p>Cutting Hazard</p> <p>KEEP HAND OFF while the blade is running. Turn power off before opening cover. Failure to follow the warning can result in severe injury.</p>
	<p>Please add antifreeze coolant when the ambient temperature is below 0°C (32°F).</p>		<p>Loose Hand Hazard</p> <p>KEEP HAND OFF. Do not touch chip conveyor. Failure to follow the warning can result in severe injury.</p>
	<p>Impact Hazard</p> <p>WEAR SAFETY SHOES. Do not approach dropping area during operation.</p>		

CAUTION Labels

Yellow and black CAUTION labels mark hazards or unsafe practices that can result in considerable personal injury.

Label	Meaning
	Keep hands out of the machine while the blade is running.
	Power to machine must be turned off when changing blades or adjusting wire brush.

NOTICE Labels

Blue and white NOTICE labels mean unsafe practices that could result in damage to products or property.

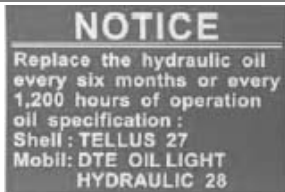
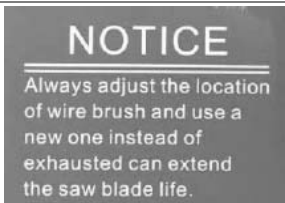
Label	Meaning
	Replace the hydraulic oil every six months or every 1,200 hours of operation. Oil specification: Shell TELLUS 27 or Mobil DTE OIL LIGHT / HYDRAULIC 28
	To extend blade life, always adjust the location of wire brush so that it is properly touching the blade. Also replace a worn wire brush with a new one.

SAFETY INSTRUCTION Labels

Green and white SAFETY INSTRUCTIONS are important reminders that should be read before operating the machine.

Label	Meaning
<p>SAFETY INSTRUCTIONS</p> <p>1. READ AND UNDERSTAND THE INSTRUCTION MANUAL AND WARNING SIGNS BEFORE OPERATING MACHINE. FAILURE TO FOLLOW THESE INSTRUCTIONS AND WARNINGS CAN RESULT IN SERIOUS INJURY OR DEATH.</p> <p>2. Do not wear gloves, neckties, jewelry or loose clothing while operating.</p> <p>3. Always wear eye protection goggle.</p> <p>4. Check blade tension and adjust blade guide before starting cut.</p> <p>5. Always clamp stock firmly in place before cutting and use auxiliary support for long material.</p> <p>6. Do not remove jammed or cut-off pieces until blade has stopped.</p> <p>7. Keep fingers out of path of blade.</p> <p>8. Guards should be in place and used at all times.</p> <p>9. Disconnect machine from power source before making repairs or adjustments.</p> <p>10. Do not operate while under the influence of drugs, alcohol or medication.</p> <p>DO NOT REMOVE OR DISFIGURE THIS SIGN</p>	<ol style="list-style-type: none"> 1. Read and understand the instruction manual and warning signs before operating machine. Failure to follow these instructions and warnings can result in serious injury or death. 2. Do not wear gloves, neckties, jewelry or loose clothing while operating the machine. 3. Always wear eye protection goggles. 4. Check blade tension and adjust blade guide before starting to cut. 5. Always clamp stock firmly in place before cutting. 6. Do not remove jammed or cut-off pieces until blade has stopped. 7. Keep fingers out of path of blade. 8. Blade guards should be in place and used at all times. 9. Disconnect machine from power source before marking repairs or adjustments. 10. Do not operate while under the influence of drugs, alcohol or medication.

Illustration: Safety Labels

SH-250R Safety Labels



CAUTION
KEEP HANDS OUT OF MACHINE



WARNING
Cutting Hazard
KEEP COVER CLOSED during sawblade running.
Turn Power OFF before opening cover.
Failure to follow the warning can result in severe injury.



WARNING
Cutting Hazard
KEEP HANDS OUT during sawblade running.
Failure to follow the warning can result in severe injury.





SH-250R

SAFETY INSTRUCTIONS

1. READ AND UNDERSTAND THE INSTRUCTION MANUAL AND WARNINGS BEFORE OPERATING ANY MACHINE. FAILURE TO FOLLOW THE INSTRUCTION MANUAL AND WARNINGS CAN RESULT IN SEVERE INJURY OR DEATH.
2. Do not wear gloves, jewelry, jewelry or loose clothing when operating.
3. Always wear your protective glasses.
4. Check blade tension and adjust blade guide before starting cut.
5. Always clamp work piece onto guide before starting cutting.
6. Do not adjust tension of cut if power unit switch has stopped.
7. Always tighten nut at path of blade.
8. Always brush up or clean and wear at all times.
9. Disconnect machine from power source before making repairs or adjustments.
10. Do not operate when under the influence of drugs, alcohol or medication.

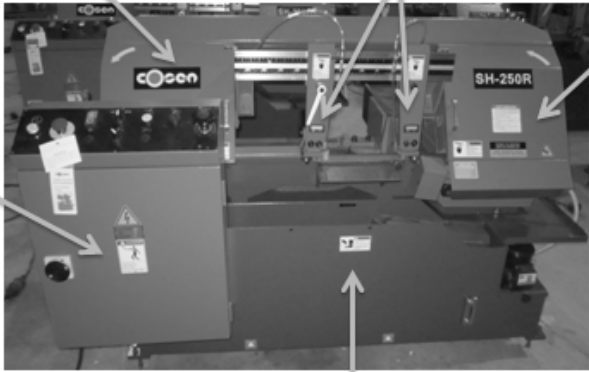
DO NOT REMOVE OR DESTROY THIS SIGN.



DANGER

POWER VOLTAGE: V
CYCLE: Hz
TOTAL POWER: KW



DANGER

Readbook before
TURN POWER OFF
before servicing.
Failure to follow the warning can result in severe injury.

WARNING
Impact Hazard
WEAR SAFETY SHOES.
Do not approach work
dropping area during
operation.



WARNING
Cutting Hazard
KEEP COVER CLOSED during sawblade running.
Turn Power OFF before opening cover.
Failure to follow the warning can result in severe injury.



POWER TO MACHINE MUST BE TURNED OFF WHEN CHANGING BLADES OR ADJUSTING CHIP BRUSH

NOTICE

Always adjust the location of wire brush and use a new one instead of exhausted can extend the saw blade life.



WARNING
Please add antifreeze coolant when the ambient temperature is below 0°C (32°F).



NOTICE
Replace the hydraulic oil every six months or every 1,200 hours of operation oil specification:
Shell: TELLUS 27
Mobil: DTE OIL LIGHT HYDRAULIC 28

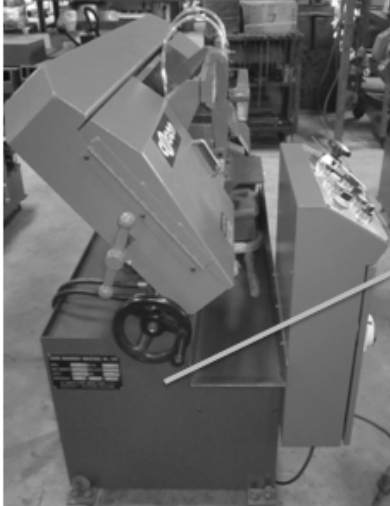

CE

COSEN MACHINERY INDUSTRIAL CO., LTD.

MODEL: _____ S/N: _____
DRIVE MOTOR HP: _____ TOTAL HP HP: _____
VOLTAGE: _____ DATE: _____
BLADE SIZE(mm): _____

11A, CHING-FU STREET Hsinchu TAIWAN, R. O. C.
TEL: 886-3-822140-1 TELEFAX: 886-3-822140

HEARING PROTECTION



Always use ear protection!

When your machine is running, noise generated by the machine may come from the following:

- Saw blade during cutting or material feed mechanism
- Wire brush unit
- Chip conveyor unit
- Speed reducer
- Hydraulic motor/pump
- Belt transmissions variable speed motors
- Blade motor
- Coolant pump
- Drive wheel
- Parts not assembled tightly causing mechanical vibration

Our products pass noise testing less than 78 dBA. Noise level vary according to working conditions and we recommend ear plugs or other hearing protection at all time. If your machine produces an undesirable noise while it is running, you should:

1. Make sure all maintenance tasks have been performed following the prescribed maintenance schedule (Refer to Section 8).
2. If maintenance does not seem to solve the problem, follow the troubleshooting procedures under Section 9.

CE COMPLIANCE

Cosen's CE model is designed to satisfy regulations of the Council Directive on the approximation of the laws of the Member States relating to machinery (2006/42/EC) - Annex I Essential health and safety requirements relating to the design and construction of machinery.

RISK ASSESSMENT

Risk assessment generally takes account of intended use and foreseeable misuse, including process control and maintenance requirements. We made every effort to avoid any personal injury or equipment damage during the machine design stage. However, the operator (or other people) still needs to take precautions when handling any part of the machine that is unfamiliar and anywhere on the machine that has potential hazards (e.g. the electrical control box).

GENERAL INFORMATION

SPECIFICATION

MACHINE PARTS IDENTIFICATION

FLOOR PLAN

This band saw machine is designed by Cosen's R&D engineers to provide you the following features and advantages:

Safety

- This machine is designed to fully protect the operator from its moving parts during cutting operation.
- The machine and each component has passed strict testing (Council Directive on the approximation of the laws of the Member States relating to Machinery).
- The machine will shut off automatically when the saw blade is broken, protecting both the operator and the machine.

Convenience & High-Performance

- The machine is designed in the way that the operation and adjustment can be easily performed.
- The machine will stop automatically when out of stock.
- Dual valve system is designed to achieve optimal cutting performance with the simple setting of feed rate and perspective cutting pressure for different material.

Durability

- The intended life-span of the machine is counted based on regular daily operation. It is calculated with the life expectancy of 10 years under normal operating condition and exact attention to the maintenance schedule.

8 hours × 5 days × 52 weeks × 10 years = 20,800 hours

SPECIFICATION

Model		SH-250R Semi-Automatic Hinge-Type Horizontal Bandsaw	
Capacity	●	250 mm (9.8 in.)	
	■	230 x 230 mm (9.0 x 9.0 in.)	
	■ (HxW)	230 x 300 mm (9.0 x 11.8 in.)	
Saw Blade	Speed	50Hz	19, 31, 48, 78 m/min (62, 102, 157, 256 ft/min)
		60Hz	23, 37, 58, 93 m/min (75, 121, 190, 305 ft/min)
	Size (LxWxT)		3350 x 27 x 0.9 mm (132 x 1.06 x 0.035 in.)
	Tension		Manual
Motor Output	Saw Blade		2 HP (1.5 kW)
	Hydraulic		0.25HP (0.18 kW)
	Coolant Pump		0.125 HP (0.1 kW)
Tank Capacity	Hydraulic		15L (3.96 gal.)
	Coolant		40L (10.56 gal.)
Workbed Height		640 mm (25")	
Gross Weight		580 kgs (1276 lbs)	
Floor Space (LxWxH)		1850 x 900 x 1040 mm (73 x 35.4 x 41 in.)	

MACHINE PARTS IDENTIFICATION

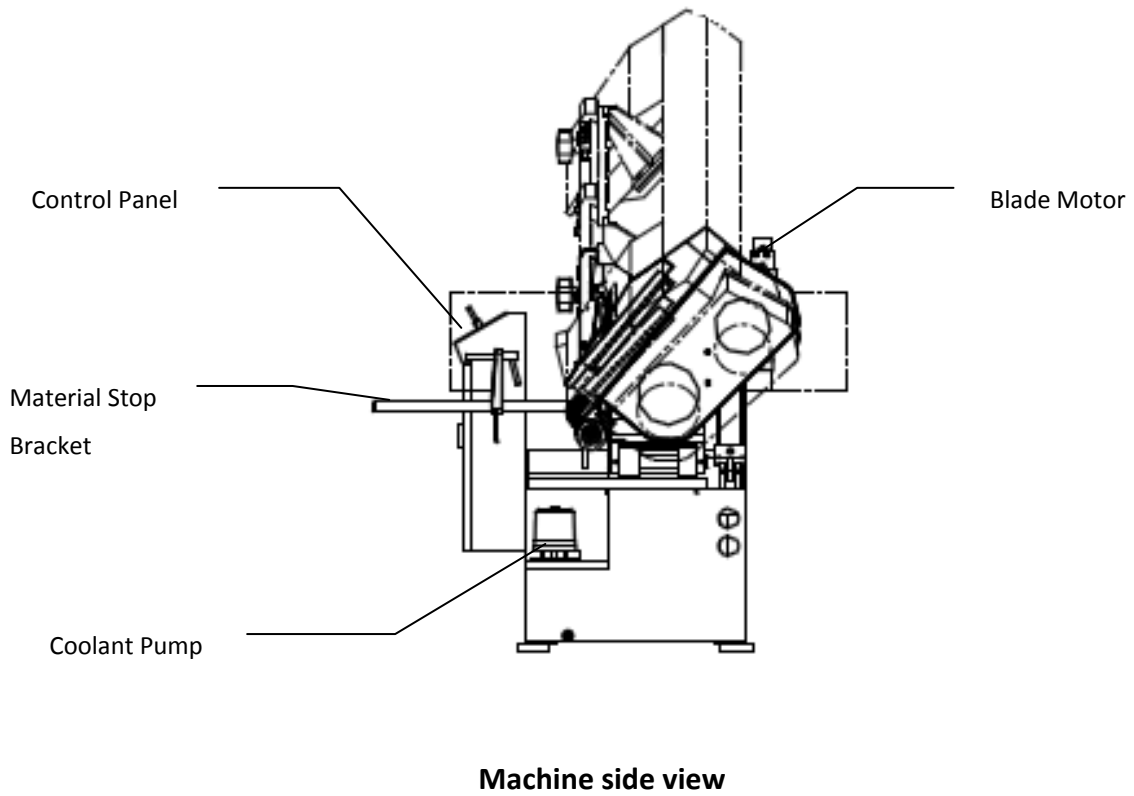
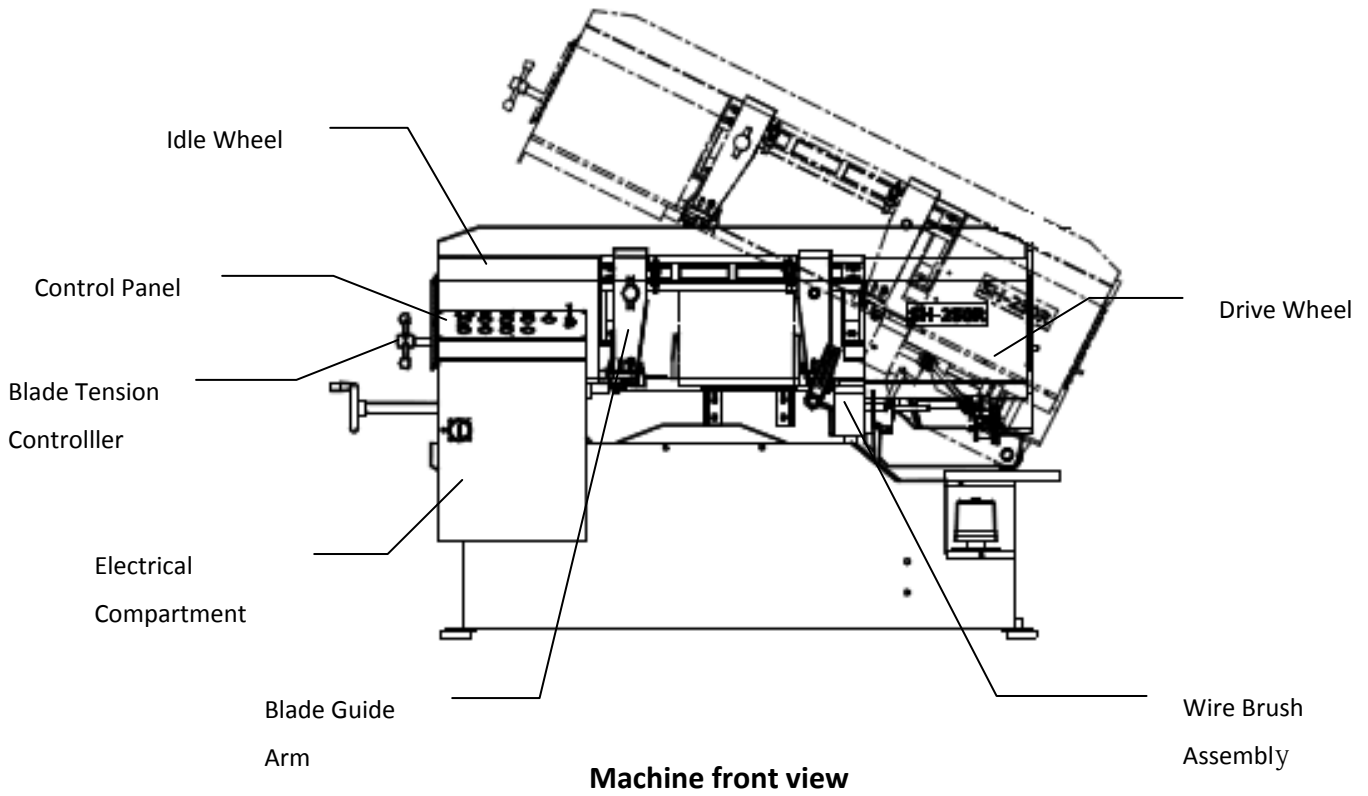

FLOOR PLAN

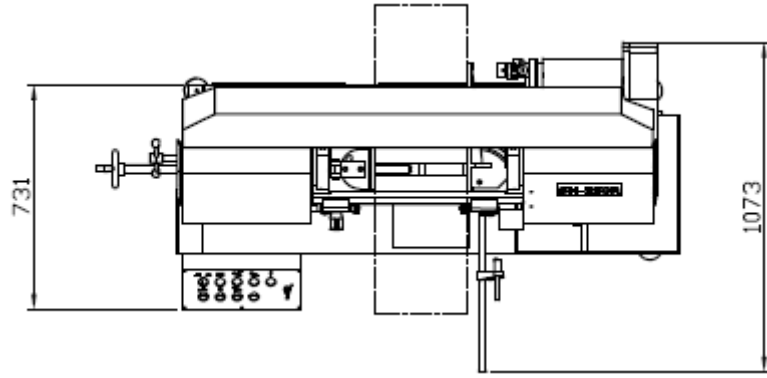

Machine top view

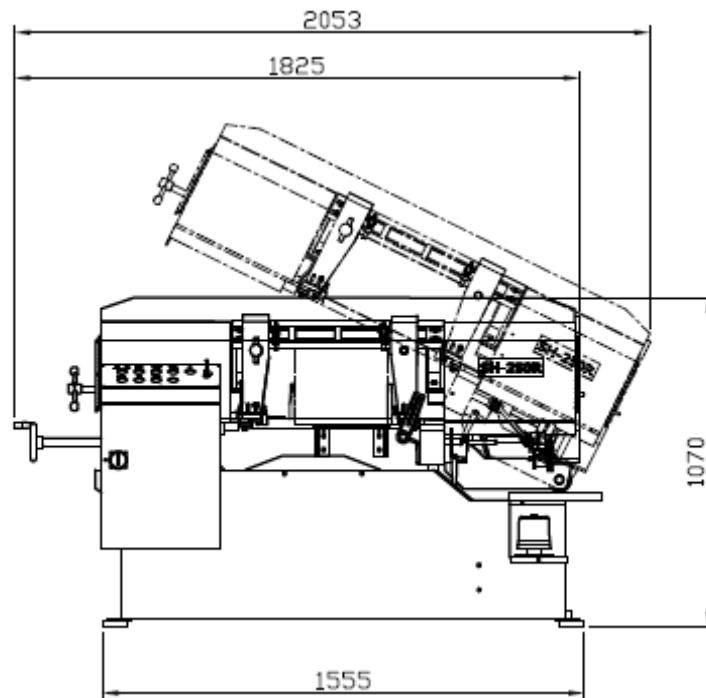

Machine front view

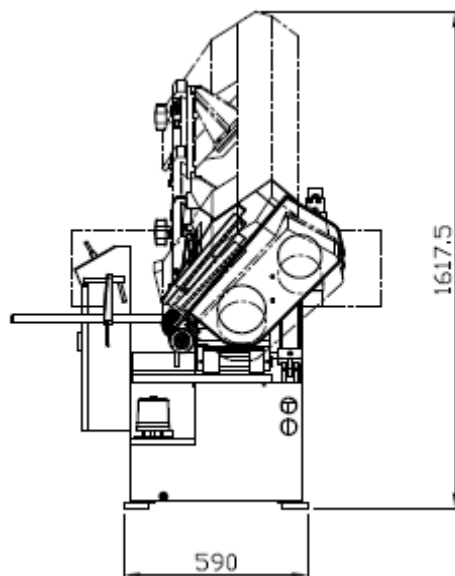

Machine side view

MOVING & INSTALLATION

LOCATION & ENVIRONMENT

UNPACKING & INSPECTING

LIFTING

REMOVING SHIPPING BRACKET

CLEANING

INSTALLING

RELOCATING

LOCATION & ENVIRONMENT

For your safety, please read all information regarding installation before proceeding. Install your machine in a place satisfying all of the following conditions:

Space:

- Leave enough free space around the machine for loading work and unloading cut-off pieces as well as for maintenance and inspection. Refer to *Section 2 Specification* for machine dimensions and floor space.

Environment:

- Well lighted (500 lumen at minimum).
- Floor kept dry at all times in order to prevent operators from slipping.
- Away from direct exposure to the sunlight
- Room temperature between 5°C to 40°C.
- Humidity level kept at 30%~95%“(without condensation) to avoid dew on electric installation and machine.
- Away from vibration of other machines
- Away from powders or dusts emitted from other machines
- Avoid uneven ground. Choose a solid level concrete floor which can sustain weight of both machine and material.
- Limit the operation area of the machine to staff only.

UNPACKING & INSPECTING

- Unpack your machine carefully to avoid damage to machine parts or surfaces.
- Upon arrival of your new band saw, please confirm that your machine is the correct model and it comes in the same specification you ordered by checking the model plate on the machine base.
- It is also imperative that a thorough inspection be undertaken to check for any damage that could have occurred during shipping. Pay special attention to machine surface, equipments furnished and the electrical and hydraulic systems for damaged cords, hoses and fluid leaks.
- In the event of damage caused during shipping, please contact your dealer and consult about filing a damage claim with the carrier.
- Your machine comes in with a set of tools for you to maintain the machine. The accessories furnished are as follows:

1.	Tool box	1 pc
2.	Grease gun	1 pc
3.	Screwdriver (+, -)	2 pcs
4.	Open-ended spanner	3 pcs
5.	Hexagon wrench	1 set
6.	Chip spade (only for manual models)	1 pc
7.	Operation manual	1 pc



Should you find any missing accessories, please contact your local agent immediately.

LIFTING

When moving the machine, we strongly suggest you choose any one of the methods described below to move your machine.

1. Use a crane

Move the machine to its location by using a crane and a wire rope sling that can fully withstand the weight of the machine (refer to machine specification under Section 2 *General Information*).

- Machine lifting is likely to damage the machine if not performed properly.



You must have a qualified crane operator to perform the job.

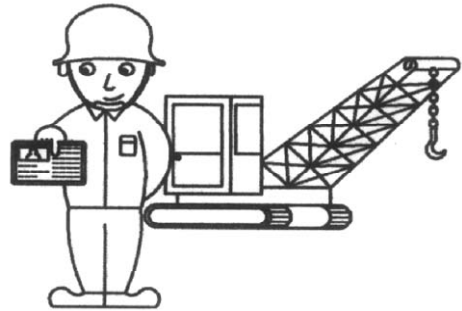

- You must use tools and equipment with the proper tensile strength and use proper method when moving your machine.

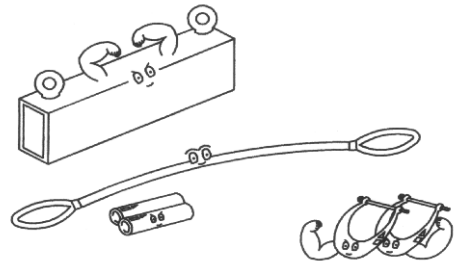

- Apply the wire rope sling to the lifting hooks on the four ends of the machine.
- Slowly lift the machine. Be sure to protect the machine from impact or shock during this procedure. Also watch out your own fingers and feet to avoid injuries.
- Keep the machine well balanced during lifting process and make sure the wire rope does not interfere with the saw frame.

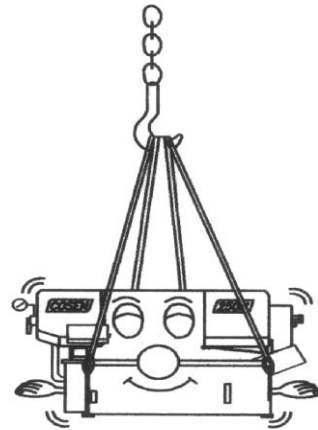

- When you work together with more than two people, it is best to keep constant verbal communication with each other.

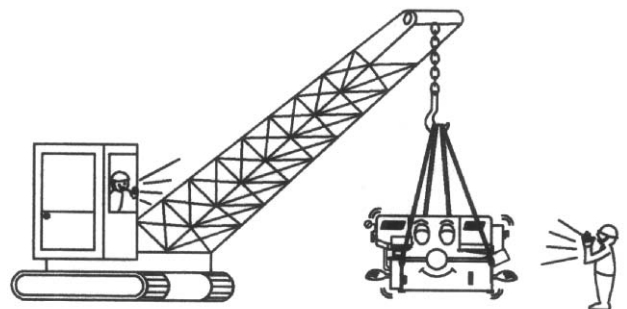

2. Use a forklift

Most users choose this method to move their machine because it is easy to set up. Make sure that the lifting rod can fully withstand the weight of the machine. (Refer to *Section 2 – General Information for Specifications*)

- Machine lifting is likely to damage the machine if not performed properly.



You must have a qualified forklift operator to perform the job.



- You must apply proper forklift technique to avoid damage to the machine.



Make sure the forks are able to reach in at least 2/3 of the machine depth.

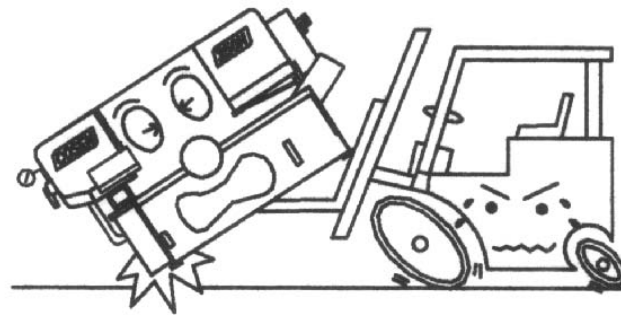

- You must keep the machine balanced at all times.



Make sure the forks are centered before use.

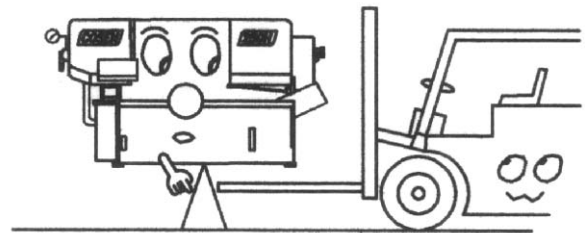

Illustration only. Refer to *Illustration: Lifting Points* for exact locations.

3. Use rolling cylinders

You can use rolling cylinders to move your machine in a small machine shop environment.

- You must use rolling cylinders made in material of proper compressive strength.

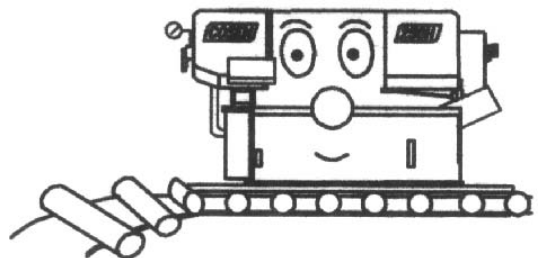
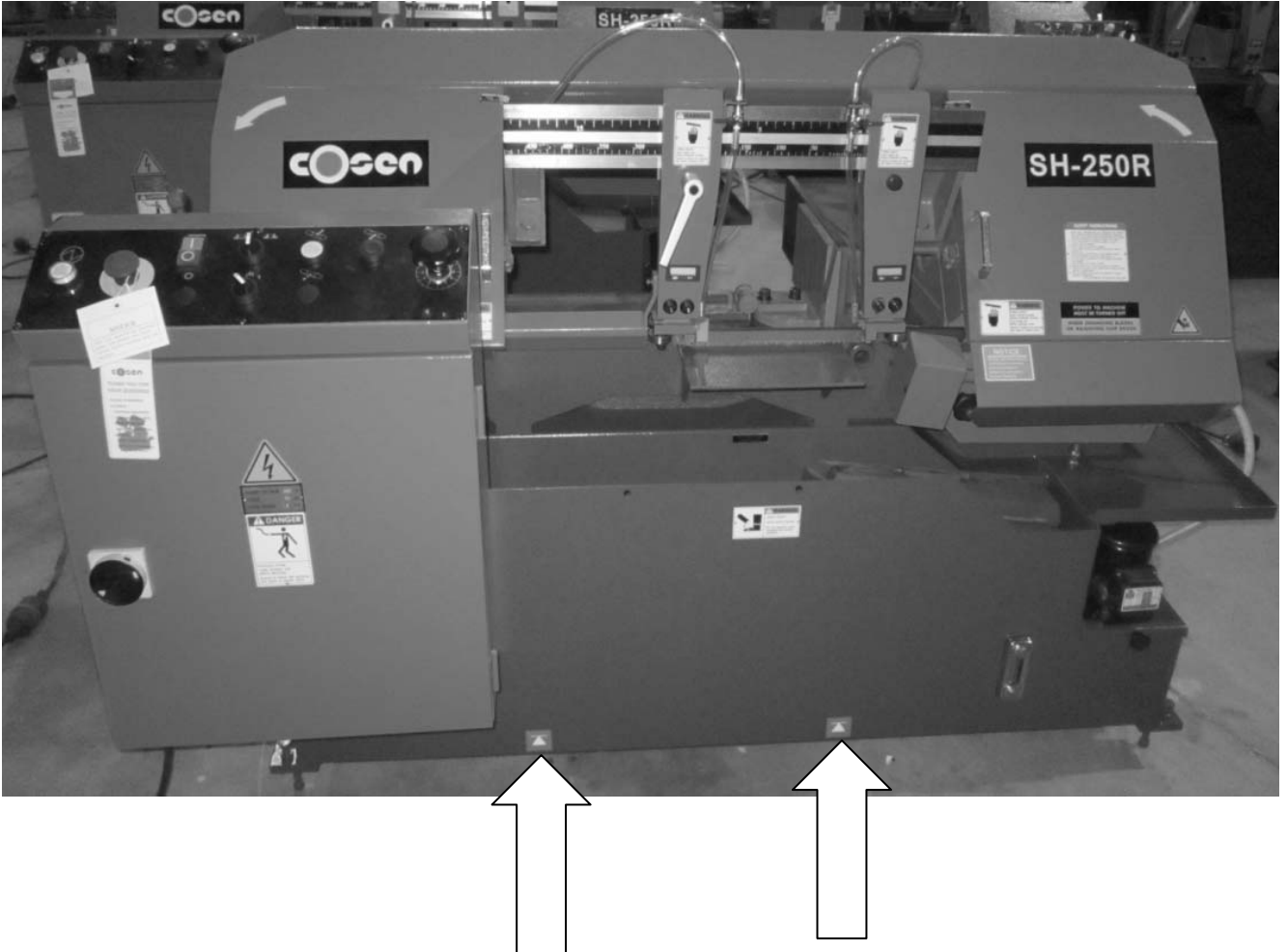

Illustration: Lifting Points



Minimum weight capacity for each lifting rod: **1 ton**
Total number of lifting rod required: **2**

REMOVING SHIPPING BRACKET

- After the machine has been properly positioned, remove the shipping bracket that is used to lock the saw frame and the saw bed.
- Retain this bracket so that it can be used again in the event that your machine must be relocated.

CLEANING

After the machine has been placed at the designated position, remove the rust-preventive grease with wiping cloth dampened with cleaning oil or kerosene. Apply machine oil to machine surfaces that are prone to rust.



Do not remove the rust-preventive grease with a metal scraper and do not wipe the painted surfaces with solvent as doing so would damage surface paint.

INSTALLING

Cosen's bandsaw machine is relatively easy to install. Follow these six easy steps to install your machine.

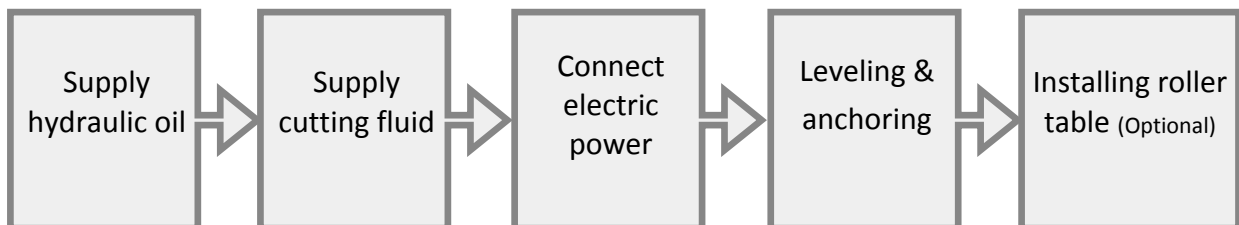

Supplying hydraulic oil

Open the filler cap and fill the hydraulic oil tank to above 2/3 or full level.

Check the sight gauge to make sure the oil level in the tank.



Refer to specification chart under Section 2 for tank capacity.



Oil tank should be full already if it is a new machine that operates for the first time.



Supplying coolant

Fill the coolant tank to the middle level of the sight gauge by pouring the coolant from above the chip conveyor.

Use the sight gauge to check the coolant level remaining in the tank.



Always check the coolant supply before starting the machine. If the coolant pump is started without enough coolant supply in the tank, the pump and its drive motor may be damaged.



Refer to specification chart under Section 2 *Specification* for tank capacity.



Consult your coolant supplier for bandsaw use regarding coolant type and mix ratio.

Connecting electric power



Have a qualified electrician make the electrical connections.



If the power supply voltage is different from the transformer and motor connection voltage shown on the label attached to the electrical compartment of the machine, contact COSEN or your agent immediately. 



Connect to power supply independently and directly. Avoid using the same power supply with electric spark machines such as electric welder. Unstable electric tension may affect your machine's electric installation from working properly.



Ground the machine with an independent grounding conductor.



Supply voltage: 90% - 110 % of nominal supply voltage.



Source frequency: 99% - 101 % of nominal frequency.



Refer to the specification chart under Section 2 for total electric power consumption of the motors and make sure your shop circuit breaker is capable of this consumption amount. Also use a power supply cable of proper size to suit the power supply voltage.

1. Turn off the shop circuit breaker.
2. Make sure the machine circuit breaker switch on the electrical compartment door is turned to OFF.
3. Remove the screw securing the electrical compartment and then open the door.
4. Pull the power supply cable and grounding conductor through the power supply inlet into the electrical compartment. (Shown right)
5. Connect the power supply cable to the circuit breaker (N.F.B.) to the R, S and T terminals, and connect the ground cable to the E terminal.
6. Close the compartment door and fasten the screw back.
7. Turn on the shop circuit breaker and then turn the machine circuit breaker switch to ON. The *Power Indicator* on the control panel will come on.
8. Pull to unlock the *Emergency Stop* button and press the *hydraulic ON* button to start the hydraulic motor.
9. Make sure the sawing area is clear of any objects. Start the blade and check the blade rotation. If the electrical connections are made correctly, the blade should run in a counterclockwise direction. If not, shut the hydraulics off, turn off the machine as well as the shop circuit breaker. Then swap the power the power cable conductors connected to R and T terminals.
10. Repeat step 6 to 9 to ensure the electrical connections are in the right order.

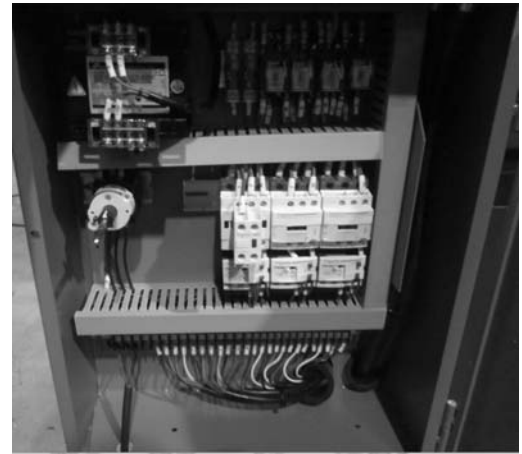

Power Supply Inlet

Leveling

Place spirit level on the vise slide plates and the work feed table.

Level the machine in both directions i.e. along and across the machine. Adjust the level of the machine by turning the leveling bolts.

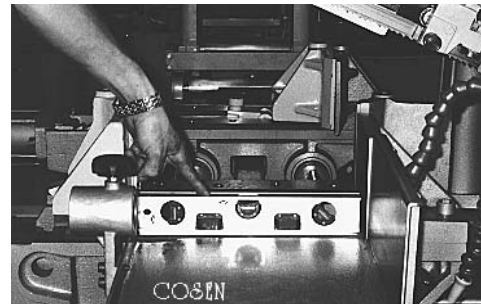

Make sure all leveling bolts evenly support the machine weight.



In some cases, leveling the machine with a slight slope toward the front of the machine is recommended as it would prevent coolant from running down cutting material especially tubes or bundles. To do so, make the rear end of the machine approximately 10 mm higher than the level of the front end.

Anchoring the machine

Normally there is no need to anchor the machine. If the machine is likely to vibrate, fix the machine to the floor with anchor bolts.

Shock absorption steel plates are provided and can be placed under each leveling bolt to prevent their sinking into the concrete floor.

Installing roller table (optional)

The roller table is used to support long material at the rear and/or the front of the machine.

If you have ordered the optional roller table for cutting long material, position it before or behind the machine.

Level the roller table and the stand with the machine by adjusting the leveling bolts.

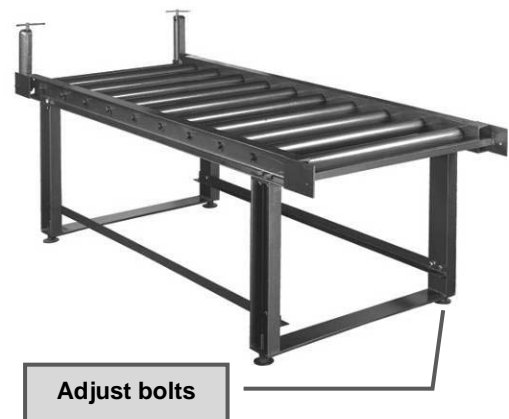

Installing Fire Control Device

Install a fire extinguisher or any other fire control device in the shop in case a fire breaks out.

RELOCATING

We recommend you follow these procedures when relocating or shipping your machine to other place:

1. Descend the saw frame to its lowest position then turn off the power.
2. Fix the saw frame using the shipping bracket that originally came with the machine.
3. If you are shipping the machine, pack the machine carefully with industrial plastic wraps to protect it from dust.
4. Use a crane or forklift to raise it. If a crane is used to lift the machine, ensure that the lifting cable is properly attached to the machine.
5. Do not forget to include the equipments originally furnished including the shock absorption steel plates and the instruction manual.

OPERATING INSTRUCTION

SAFETY PRECAUTIONS

BEFORE OPERATING

CONTROL PANEL

STANDARD ACCESSORIES

OPTIONAL ACCESSORIES

UNROLLING & INSTALLING THE BLADE

ADJUSTING BLADE SPEED

ADJUSTING SAW ARM

ADJUSTING COOLANT FLOW

ADJUSTING VISE

INSTALLING MATERIAL STOP BRACKET

ADJUSTING WIRE BRUSH

ADJUSTING HORIZONTAL STOP SPRING CUSHION

TEST-RUNNING THE MACHINE

BREAKING-IN THE BLADE

CUTTING OPERATION

TERMINATING A CUTTING OPERATION

SAFETY PRECAUTIONS

For your safety, please read and understand the instruction manual before you operate the machine.

The operator should always follow these safety guidelines:

- The machine should only be used for its designated purpose.
- Do not wear gloves, neckties, jewelry or loose clothing/hair while operating the machine.
- For eye protection, always wear protective safety glasses.
- Check the blade tension and adjust blade guides before starting the machine.
- Use auxiliary clamping or supporting devices to fix material in place before cutting long workpieces. Always make sure the material is clamped firmly in place before starting to cut.
- Do not remove jammed or cut-off pieces until the blade has come to a full stop.
- Keep fingers away from the path of the blade.
- Protection devices should be in place at all times. For your own safety, never remove these devices.
- Disconnect machine from the power source before making repairs or adjustments.
- Wear protection gloves only when changing the blade.
- Do not operate the machine while under the influence of drugs, alcohol or medication.
- Do not take your eyes off the machine while in operation.
- Do place warning signs to mark out machine work zone and restrict entry to be staff-only.

BEFORE OPERATING

Choosing an appropriate saw blade and using the right cutting method is essential to your cutting efficiency and safety. Select a suitable saw blade and cutting method based on your work material and job requirements e.g. cutting accuracy, cutting speed, economic concern, and safety control.

Wet cutting

If you choose dry cutting or low-speed cutting, the chips may accumulate in machine parts and may cause operation failure or insulation malfunction. We suggest you choose wet cutting to avoid machine damage.

Cutting unknown materials

Before cutting an unknown material, consult the material supplier, burn a small amount of chips from the material in a safe place, or follow any other procedure to check if the material is flammable.



Never take your eyes off the machine while in operation.

Cutting fluid

For cooling and lubrication purpose, we recommend you use water-soluble cutting fluids. The following table lists out its pros and cons for your reference.

Pro	Con
<ul style="list-style-type: none">• Have a high cooling effect• Not flammable• Economical• Does not require cleaning of the cut products	<ul style="list-style-type: none">• Remove machine paint• Lose its rust protection effect if deteriorated• Tend to create foam• Subject to decay• Decline in performance, depending on the quality of the water used for dilution



Never use water as your coolant.



Always add coolant into water for better mix result.



Consult your coolant supplier for bandsaw use regarding coolant type and mix ratio.



Before starting a cutting job, make sure there is sufficient amount of coolant in the tank. Check the fluid level through the sight gauge. Please refer to machine specifications in this manual (Section 2) for tank capacity.

CONTROL PANEL

The control panel is located on the top of the electrical box. It includes the following function: power system, hydraulic system and cooling system. The operator must fully understand the function of each switch and button before operating the machine.

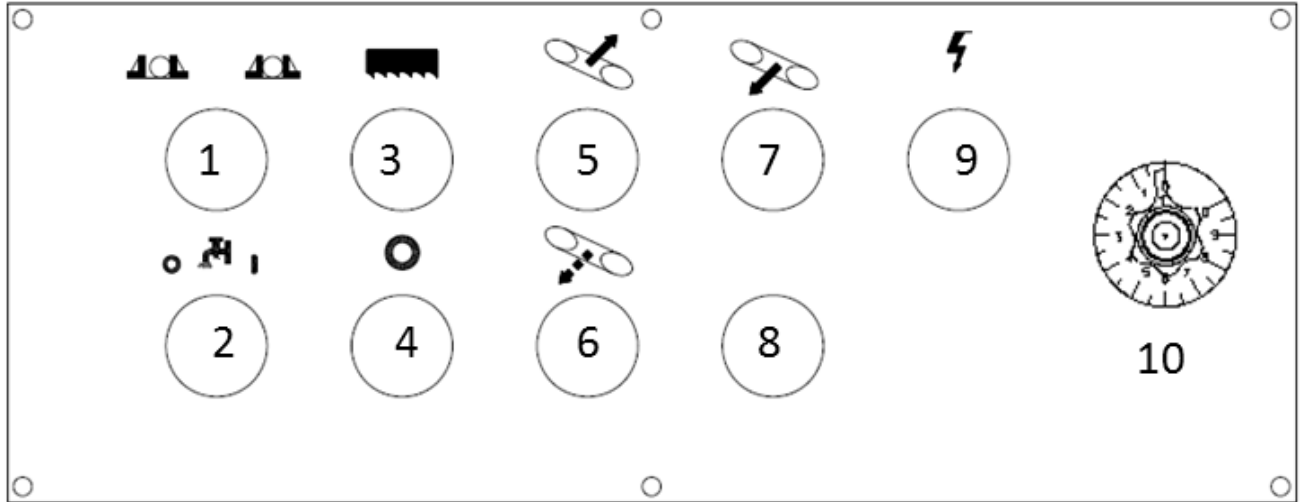

non-CE model

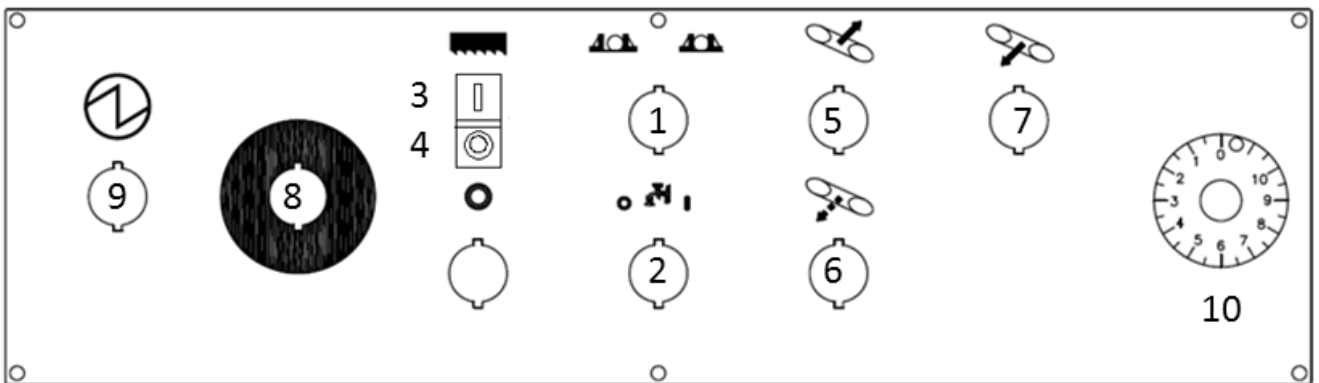

CE model

No.	Control Function	No.	Control Function
1	Vise open/clamp switch	6	Saw bow slowly down button (N/A)
2	Coolant pump on/off switch	7	Saw bow down button
3	Saw blade start button	8	Emergency stop button
4	Saw blade stop button	9	Power indicator lamp
5	Saw bow up button	10	Blade descend speed control knob

Control Buttons

1. Vise open/clamp switch

When the switch is turned to the left, the vises open. When the switch is turned to the right, the vises close until the operator lets go of the switch or until the full stroke vises are clamped together.



After the blade motor is running, the function of this switch is disabled for the safety concern.

2. Coolant pump on/off switch

When this switch is set at “|”, the coolant pump operates and the cutting fluid will be injected. When this switch is set at “O”, the coolant pump stops and cutting fluid supply will be terminated.



Cutting fluid can lower the workpiece temperature during cutting.

3. Saw blade start button

Press this button to start the blade motor.



Make sure the material is securely clamped by the vise before cutting.

4. Saw blade stop button

Press this button to stop the blade motor.



After the cutting job is done, the saw blade will stop and the saw bow will automatically go up to the top limit switch position.

5. Saw bow up button

When this button is pressed, the saw bow rises until the operator lets go of the button.



While pressing the *saw bow up* button can stop the running blade, please still make use of the *emergency stop* button in an emergency.

6. Saw bow slowly down button(N/A)

7. Saw bow down button

When this button is pressed, the saw bow descends according to the preset speed of *blade descend speed control knob*.



Before descending the saw bow, please move the guide arm to a safe position to prevent it from hitting the vise.



Press *saw bow up button* to stop saw bow descending.

8. Emergency stop button

Press this button to stop the machine in an emergency. When the button is pressed, it brings the machine to a full stop. The button locks when pressed. In order to unlock it, please turn the button clockwise.

9. Power indicator lamp

When the lamp is on, it indicates the power to the machine is turned on.

10. Blade descend speed control knob

This knob is used to adjust the descend speed of the saw blade. Turning the knob counterclockwise increases the blade descend speed.

STANDARD ACCESSORIES

Blade tension device



- This blade tension device provides appropriate tension to the saw blade.
- Turn the handle clockwise or counterclockwise to tighten or loosen the blade tension.
- Please check the blade tension with the tensiometer.



Never adjust blade tension while the blade is running.

Wire brush

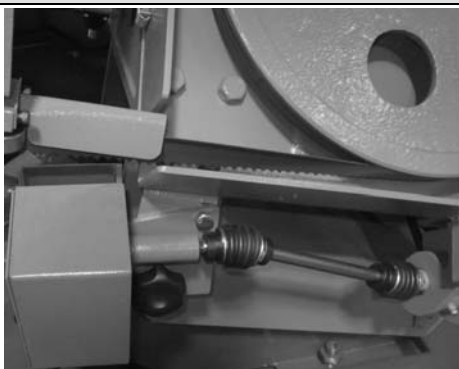

The wire brush is driven by the pulley system to rotate at the same speed as the blade motor. It removes the metal chips on the saw blade teeth so that blade life can be extended.



Keep hands away from the transmission shaft and the brush while the wire brush is running.



Turn off the hydraulic motor or the main power switch before performing maintenance or cleaning on the wire brush drive system.

Coolant pump



The coolant pump supplies coolant to cool off cutting temperatures during cutting. Also, it can be used to wash off chips.

Gear reducer



Gear
reducer

The specially designed gear reducer can work toward your preset blade speed and torque.



Please refer to section 8 for information on maintenance.

OPTIONAL ACCESSORIES

Single Roller Table



This single roller table supports the work material and ensures the material is fed in smoothly.

1M Roller Table



The optional 1M roller table supports the work material and ensures the material is fed in smoothly.

2M Roller Table



The optional 2M roller table supports the work material and ensures the material is fed in smoothly.

UNROLLING & INSTALLING THE BLADE



Always wear leather gloves and protection glasses when handling a blade.

Unrolling the blade

Please follow the procedures illustrated below.

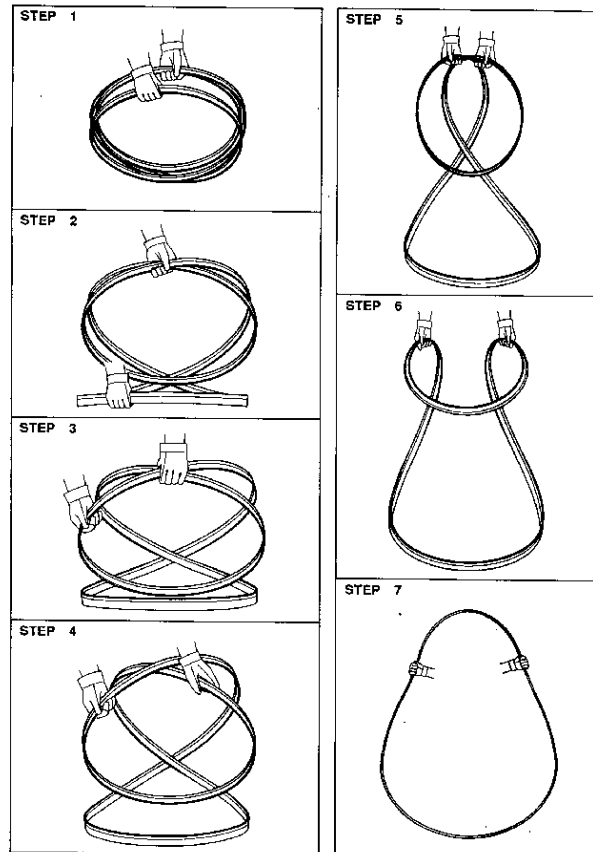

Installing a new blade

Step 1 - Select the most suitable saw blade for your workpiece considering the size, shape and material.

Step 2 - Turn on the machine power.

Step 3 - Press the *saw bow up* button and elevate the saw bow to the highest position.

Step 4 - Release blade tension by turning the blade tension handle counterclockwise. The idle wheel will then move slightly toward the direction of the drive wheel.



Step 5 - Open the idle and drive wheel covers.

Step 6 - Loosen the lock knob screw and lower the wire brush.

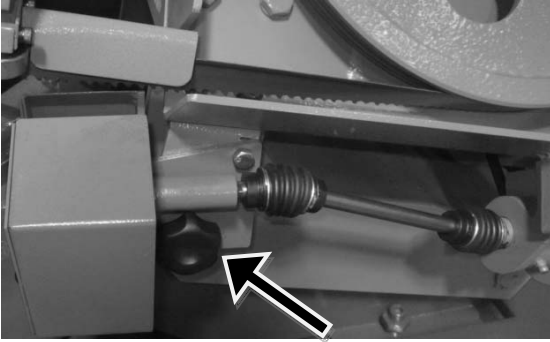

Step 7 – Remove the old blade. If necessary, clean the carbide inserts before installing a new saw blade.

Step 8 - Place the new blade around the idle wheel and the drive wheel.

Step 9 - Insert the blade into the left and right tungsten carbide inserts. The back and the sides of the blade need to be touching the inserts as well as the adjacent rollers.



Step 10 - Place the blade to the drive wheel and press the back of the blade against the flange of the drive wheel.

Step 11 - Make sure the back of the blade is also pressed against the flange of the idle wheel.

Step 12 - Apply tension by turning the blade tension handle clockwise. Make sure you have proper blade tension. Proper tension exists when the blade does not slip on the drive wheel when cutting.

Step 13 - Make sure the sides of the blade are in close contact with the carbide inserts.

Step 14 - Gently close the idle and drive wheel covers.

Step 15 - Press the *saw blade start* button to start the blade. Allow the blade to run for a few rotations then press the *saw bow up* button to elevate the saw bow. Open the wheel covers and make sure the blade has not fallen off the drive and idle wheels. If the blade has shifted, follow the same procedure to reinstall the blade again.

Step 16 - Adjust wire brush to a proper position. Refer to *Adjust wire brush* in this section.

ADJUSTING BLADE SPEED

According to operator's need, two kinds of pulleys can be chosen to adjust blade speed.

Step pulley

Step 1 - Remove pulley cover

Step 2 - Loosen lock handle

Step 3 - Position belt in proper grooves according to the blade speed chart.

Step 4 - Make sure the belt is tightly and securely positioned in the groove and tighten lock handle.

Step 5 - Install pulley cover back in place.

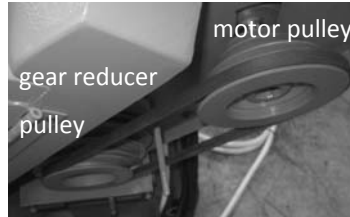
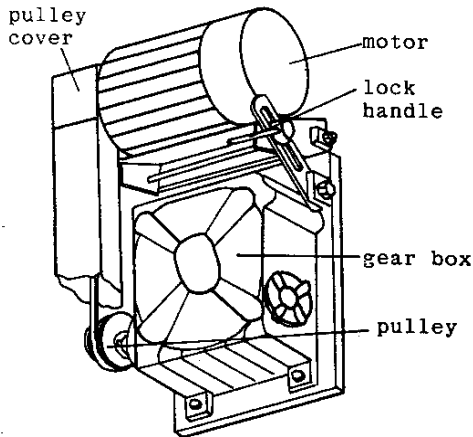

BLADE SPEED FEET / METER PER MINUTE	
50HZ	60HZ
78/24	95/29
124/38	150/46
173/53	213/65
265/81	321/98

Variable stepless pulley(optional)

Step 1 – Set the blade speed control knob to “0” position.

Step 2 – Press the *saw blade start* button to start the blade.

Step 3 – Refer to blade speed reference chart and turn the *blade speed control knob* to adjust the blade speed. Turn clockwise to decrease the speed and counterclockwise to increase the speed.

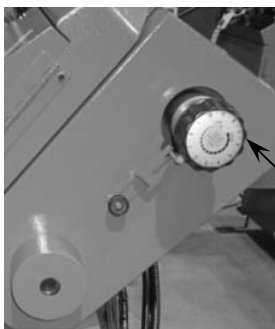

Blade Speed Control Knob



Blade Speed Reference Chart

ADJUSTING SAW ARM

Adjust the blade guide (movable guide arm) position based on the size of your workpiece:



While adjusting the guide arm, be careful not to hit the vise.

Step 1 – Loosen the blade guide locking handle. Then adjust the guide arm to a position suitable for your workpiece size.

Step 2 – After adjustment is made, tighten the blade guide locking handle.



Locking Handle

ADJUSTING COOLANT FLOW

Step 1 – Press the *saw blade start* button to start the saw blade drive motor.

Step 2 – Use the flow control valve (shown below) to adjust the amount of fluid flowing to the cutting area.



Flow Control Valve



Adjust the flow amount if you observe the following changes to the chips generated from cutting.



If the chips are sharp and curved, increase the coolant flow amount.

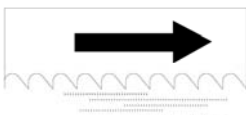

If the chips are granulated, decrease the coolant flow amount.

ADJUSTING VISE



Always use the vise to clamp the work. Never hand-hold the work for cutting.

Angle cutting

The vise offers the user great flexibility in angle cutting from 0° to 45°.

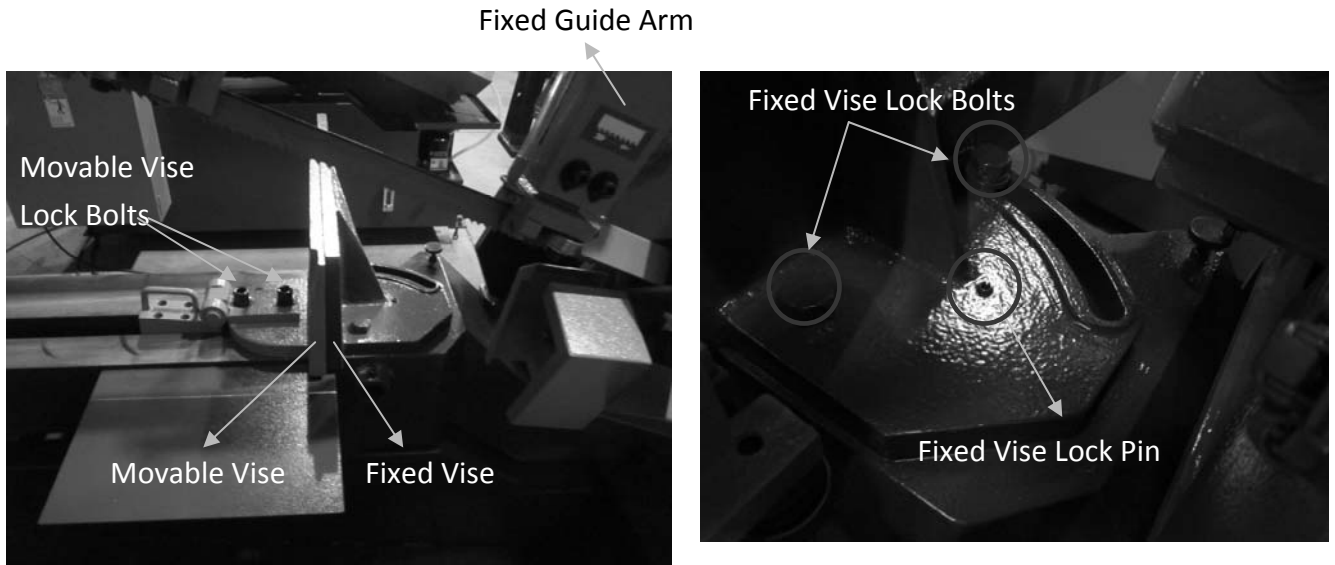

Step 1 - Remove the fixed vise lock pin.

Step 2 - Move the fixed guide arm to the furthest right end.

Step 3 - Lift the saw bow up to the highest position.

Step 4 - Wire brush cannot be used for angle cutting. Loosen the lock knob screw and move the wire brush to the lowest position. Refer above *Adjusting Wire Brush*.

Step 5 - Loosen the fixed vise lock bolts and movable vise lock bolts. Then adjust the fixed vise and movable vise until they are 45° to saw blade with an accurate square instrument (see below figure). Tighten the lock bolts.

Step 6 - Clamp the workpiece with the movable vise.

Step 7 - When repositioning the vise for 90° cutting, install the fixed vise lock pin and make sure it is square with an accurate square instrument.

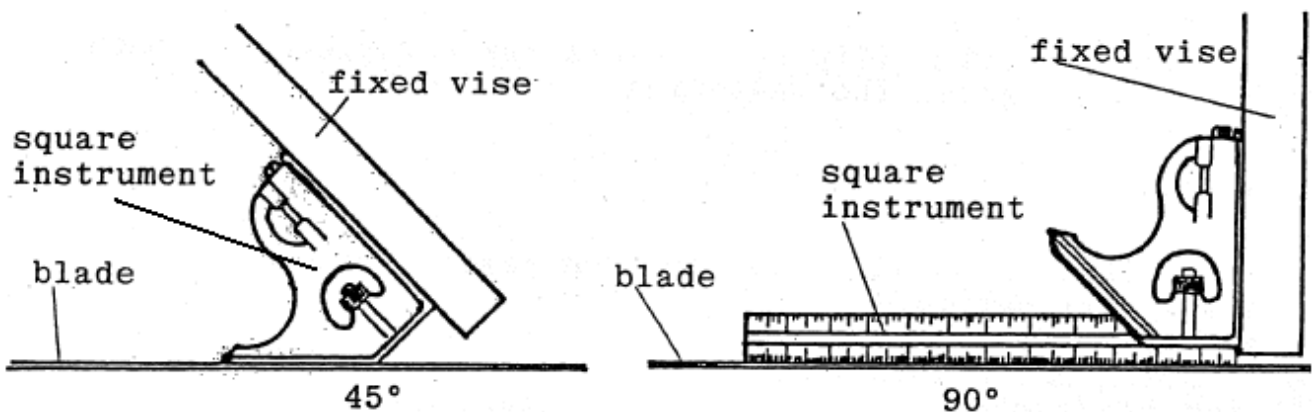

Quick adjusting movable vise position

To quickly adjust movable vise position, please follow below steps.

Step 1 - Lift up the pawl and move the movable vise toward workpiece until it stands against the workpiece.

Step 2 - Turn the movable vise handwheel to clamp the workpiece securely.



INSTALLING MATERIAL STOP BRACKET

This device is easy to cut the same length repeatedly and saves adjusting time.

Step 1 - Install the depth bar and tighten the set screw. The depth bar is taken off from the machine base during transit for safety reason.

Step 2 - Lift the saw bow and clamp material securely with vise.

Step 3 - Lower the saw bow to allow about 1 mm clearance between saw blade teeth edge and the top of the material. Then measure your desired cutoff length.

Step 4 - Loosen the fastening bolt.

Step 5 - Slide and position the stopper so that the end of stopper faces the direction of the front end of the material. Then tighten the stopper handle to fix the stopper in the bracket.

Step 6 - Move the stopper bracket toward the workpiece so the stopper end just touches the front of the material, then tighten the fastening bolt.

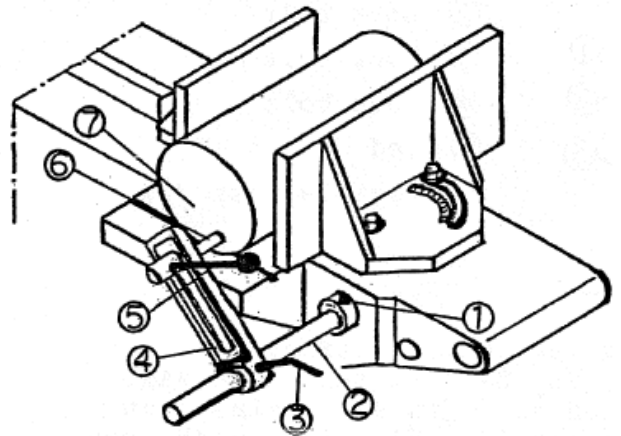

- ① Set screw
- ② Depth bar
- ③ Fastening bolt
- ④ Stopper bracket
- ⑤ Stopper handle
- ⑥ Stopper
- ⑦ Front end of material

ADJUSTING WIRE BRUSH

Follow these steps to adjust wire brush to appropriate position:

Step 1 – Loosen the lock knob screw.

Step 2 – Adjust brush to make it move up / down until it makes proper contact with the saw blade
(see below illustration).

Step 3 – Tighten the lock knob screw.

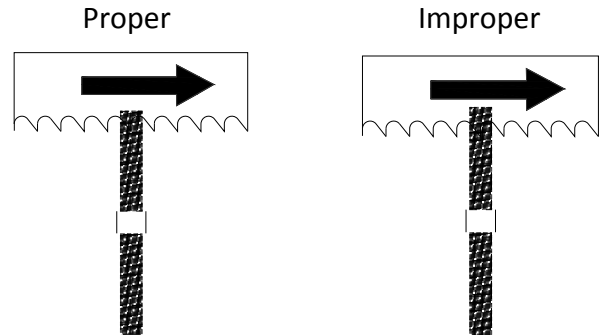
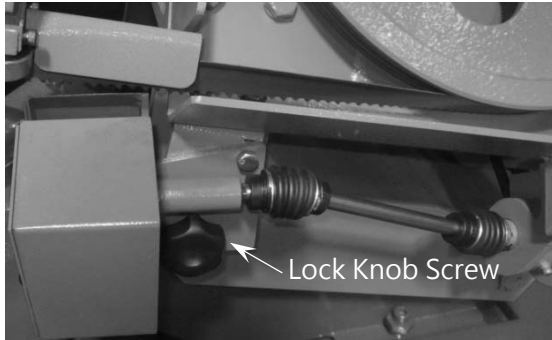

ADJUSTING HORIZONTAL STOP SPRING CUSHION

Complete Cut – Adjusting Horizontal Stop Spring Cushion

The workpiece should be able to cut through completely. If it does not, please follow these steps to adjust the horizontal stop spring cushion.



Always make sure the power cord is disconnected from power source when making adjustments.

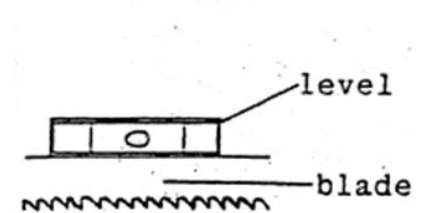
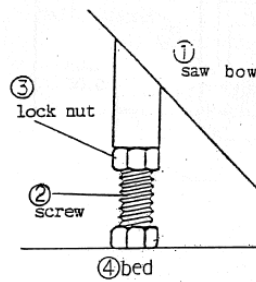

Step 1 - Place a level on the workbed to make sure the bed is level.

Step 2 - Loosen the lock nut and lower down the saw bow. Place the level on top of the saw blade to check its leveling against the bed horizontal line. Adjust the screw until the blade is level.

Step 3 - Tighten the lock nut when leveling is obtained.



If the saw blade top line is not leveled against the bed horizontal line, the workpiece will not be able to cut off completely.

Automatic Shut-Off – Adjusting Horizontal Stop Spring Cushion

The motor should shut off immediately after the blade has cut through the material and right before the head comes to rest on the horizontal stop spring cushion. If it does not, the spring cushion must be adjusted.

Step 1 - Check the horizontal stop spring cushion. Refer to “Complete Cut – Adjusting Horizontal Stop Spring Cushion.”

Step 2 - Raise the saw bow and press the *saw blade start button*. Lower the saw bow slowly and observe the switch mechanism.

TEST-RUNNING THE MACHINE

Test-running this machine can ensure good machine performance in the future. We suggest you run the following tests on the machine before first use:

Testing machine performance:

Turn on the power and run a basic performance test after you finish installing the machine. Follow these steps to test machine performance:

Step 1 – Disassemble shipping brackets and bolts.

Step 2 – Install roller table(optional).

Step 3 – Turn on the relay switch in the control box.

Step 4 – Elevate the saw bow. (If your coolant pump is in reverse and the machine cannot run, please change the electrical phase.)

Step 5 – Remove the rust-prevention grease with cleaning oil or kerosene.

Step 6 – Start the coolant pump.

Step 7 – Test these functions:

- vise clamping/unclamping
- saw bow ascending/descending

BREAKING-IN THE BLADE

When a new saw blade is used, be sure to first break in the blade before using it for actual, extended operation. Failure to break in the blade will result in less than optimum efficiency. To perform this break-in operation, the following instructions should be followed:

Step 1 - Reduce the blade speed to one-half of its normal setting.

Step 2 - Lengthen the cutting time to 2-3 times of what is normally required.

Step 3 - After the break-in operation is completed, set all parameters back to normal settings.

CUTTING OPERATION

Step 1 – Check before you cut

- **Power:** Check the voltage and frequency of your power source.
- **Coolant:** Check if you have sufficient coolant in the tank.
- **Hydraulic:** Check if you have sufficient (at least two-thirds or higher) hydraulic oil.
- **Blade:** Check the blade teeth and make sure there is no worn out teeth along the blade.
- **Saw bow:** Check the saw bow to see if it can be elevated and lowered smoothly.

Step 2 – Place your workpiece onto the workbed manually or by using a lifting tool e.g. a crane.



Before loading, make sure the vises are opened to at least wider than the width of the workpiece.

Step 3 – Position your workpiece.

Step 4 – Clamp the workpiece.

Step 5 – Adjust *blade descend speed control* knob to obtain a suitable blade descend speed for your material.

Step 6 – Start running the blade.



Before you start cutting, check again that there is no other object in the cutting area.

Step 7 – While the blade descends, adjust the blade speed if necessary. Please refer to *Adjusting Blade Speed*.

Step 8 – Select the proper cutting condition according to different material.

Step 9 – After the entire cutting job is completed, open the vises to remove the workpiece.

Step 10 – Clean the workbed by removing chips and cutting fluids.

Step 11 – Lower the saw bow to a proper position then turn off the power.



TERMINATING A CUTTING OPERATION

- To terminate a cutting operation, press the *saw bow up* button, the *saw blade stop* button, or the *emergency stop* button.
- The saw blade will stop running when the *saw bow up* button or the *saw blade stop* button is pressed.
- Both the saw blade and hydraulic pump motors will stop running when the *emergency stop* button is pressed.

ELECTRICAL SYSTEM

ELECTRICAL CIRCUIT DIAGRAMS

The following are electrical circuit diagrams of the system:

Non-CE model

Fig. 5-1 Circuit Board and Power Supply Layout

Fig. 5-2 PLC Input/Output Layout

Fig. 5-3 Control Panel Layout

CE model

Fig. 5-4 Power Supply Layout

Fig. 5-5 Circuit Board Layout 1

Fig. 5-6 Circuit Board Layout 2

Fig. 5-7 Control Panel Layout

上 : 0.1.2.3.5.6.7.8.10.11.12.26
 下 : 12.13.2.15.18.19.11.0.10.0.29.7.0.26-1.0.27.0
 CSA : 12.13.2.15.18.19.10.11.0.0.29.7.0.0.26-1.27.0.0

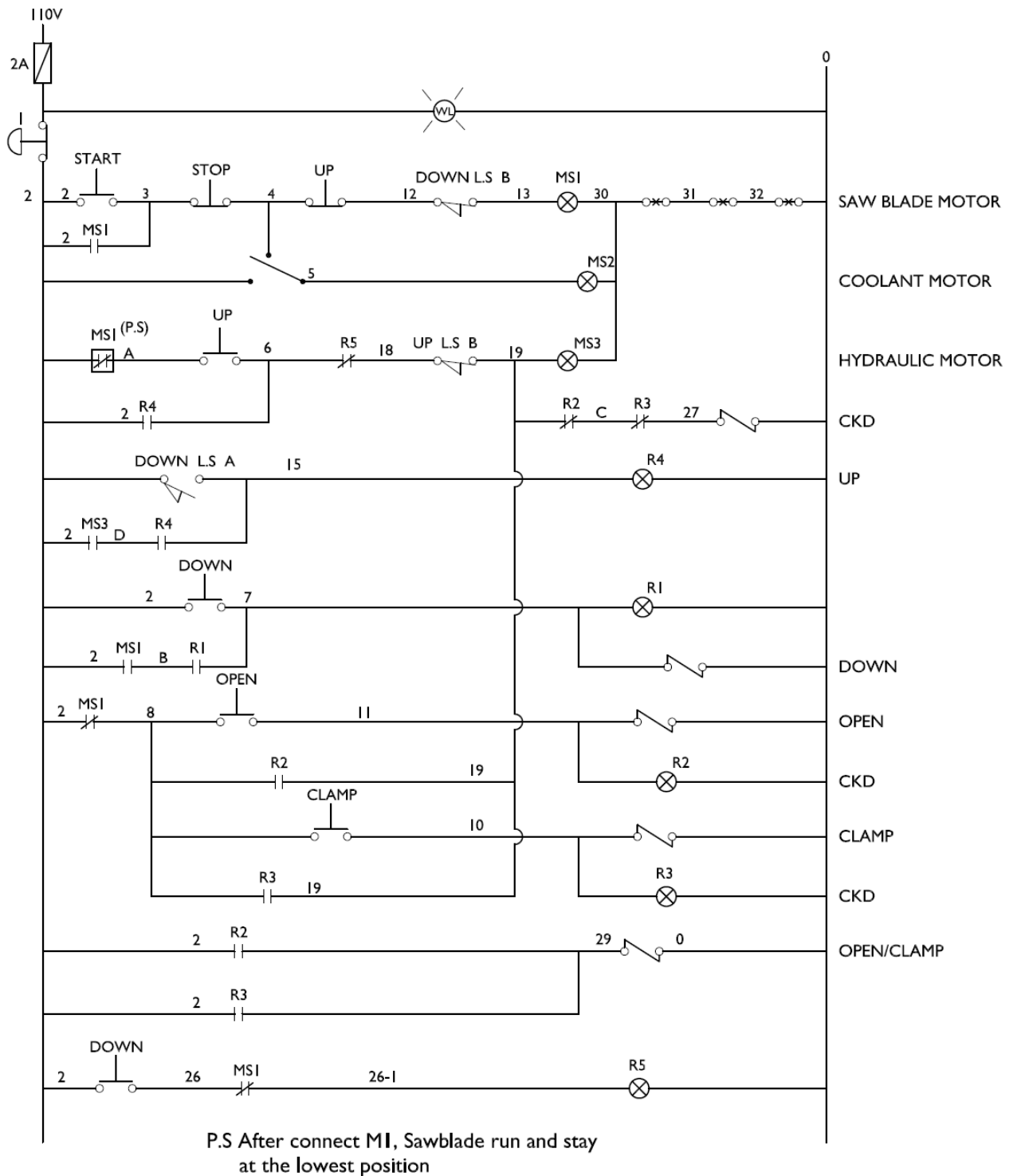

WITH HYDRAULIC VISE

高聖機械工業股份有限公司 Cosen Machinery Industrial Co., Ltd.	圖名 動力配置圖 線路配置圖	圖號 EL-SH250R	繪圖	鍾泓龍	日期	1020422	版本
			審核		日期		S1

Fig. 5-1 Circuit Board and Power Supply Layout (non-CE model)

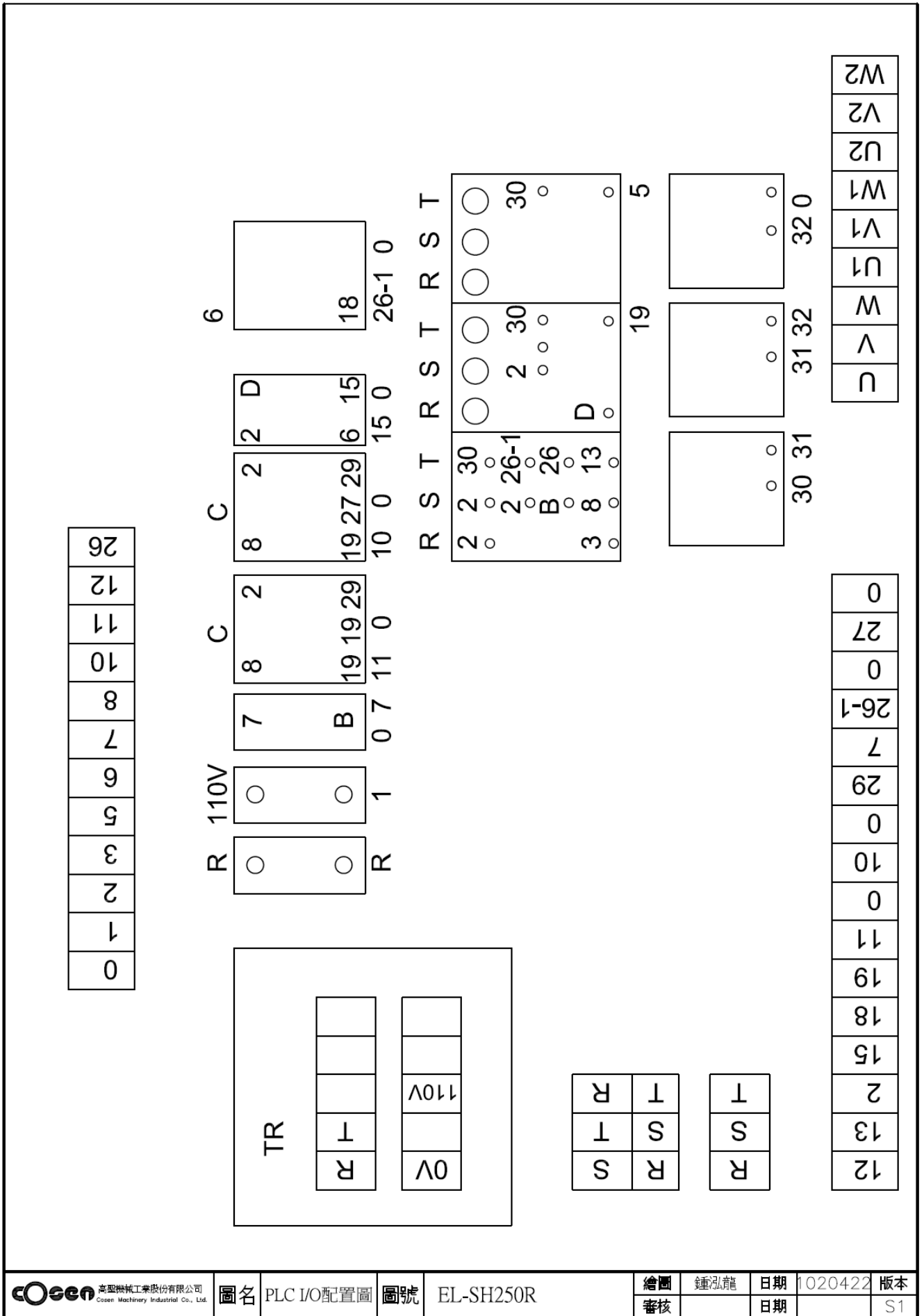
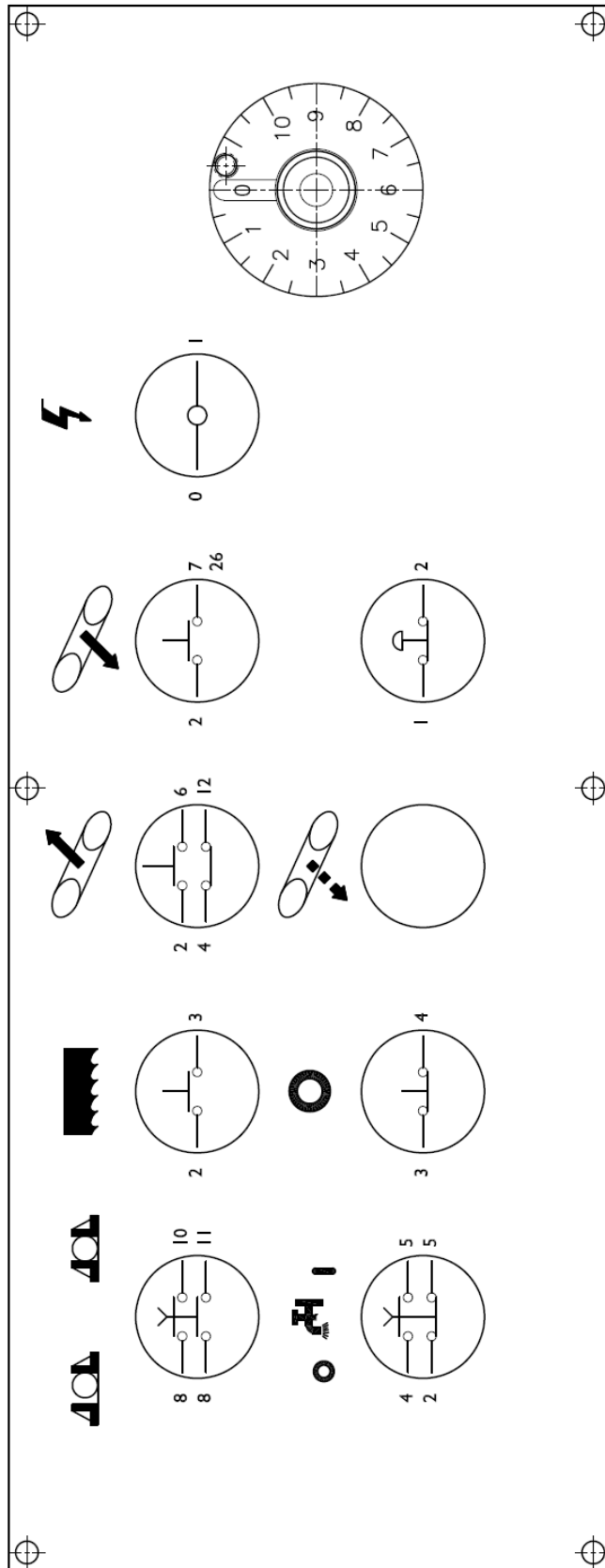

Fig. 5-2 PLC Input/Output Layout (non-CE model)

高聖機械工業股份有限公司 Cosen Machinery Industrial Co., Ltd.	圖名	PLC I/O配置圖	圖號	EL-SH250R	繪圖	鍾泓龍	日期	1020422	版本
	審核						日期		S1



高聖機械工業股份有限公司 Cosen Machinery Industrial Co., Ltd.	圖名	操作面板	圖號	EL-SH250R	繪圖	鍾泓龍	日期	1020422	版本
					審核		日期		S1

Fig. 5-3 Control Panel Layout (non-CE model)

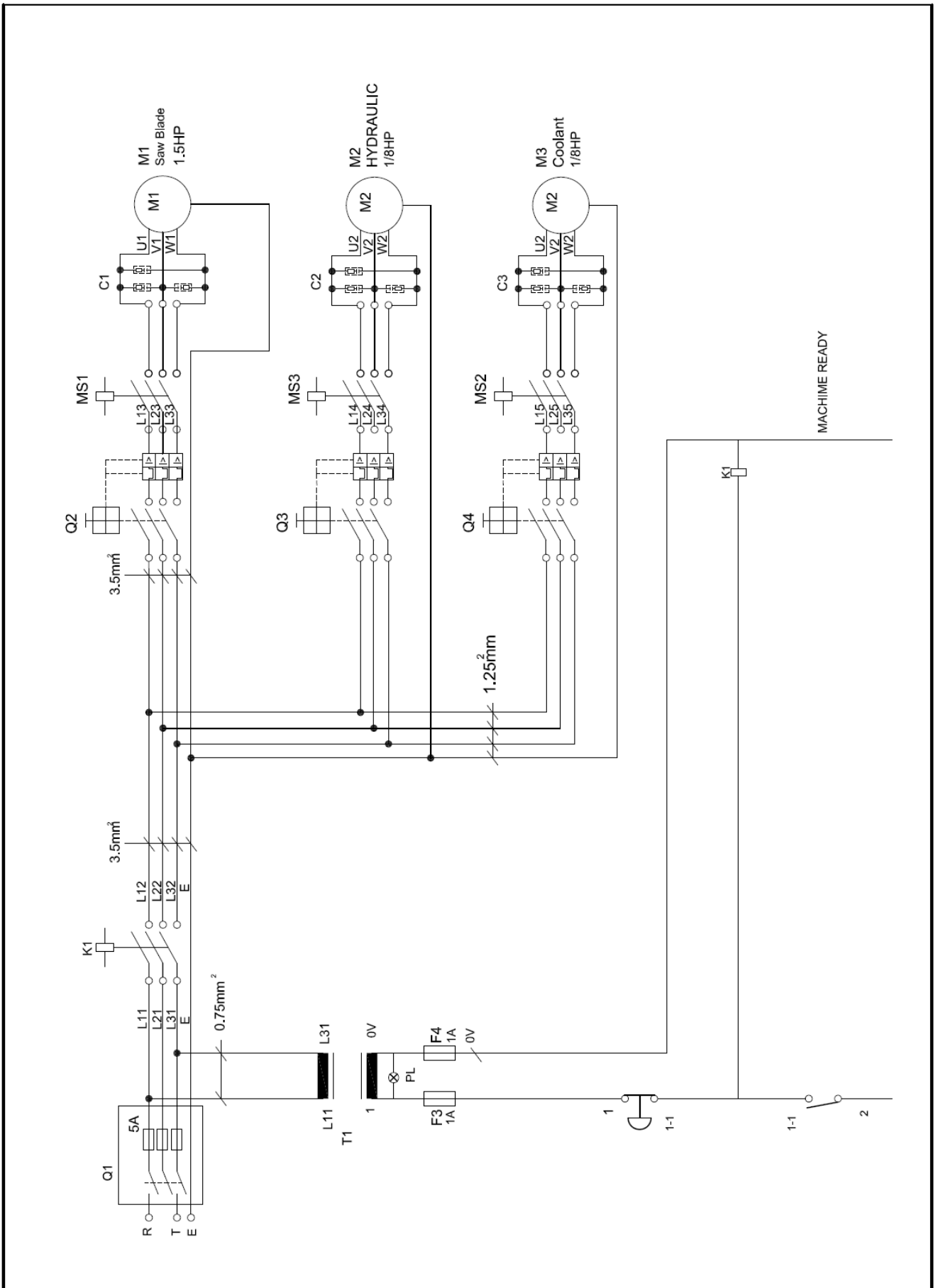

高聖精密機電股份有限公司 COSEN MECHATRONICS CO., LTD.	圖名	Power Supply Layout 動力配置圖	圖號	EL-SH250R (CE)	繪圖	鍾泓龍	日期	1030110	版本
					審核		日期		S0

Fig. 5-4 Power Supply Layout (CE model)

UP上 : 0.1.2.3.5.6.7.8.10.11.12.26
 Down下 :
 12.13.2.15.18.19.11.0.10.0.29.7.0.26-1.0.27.0.33.34
 CSA : 12.13.2.15.18.19.10.11.0.0.29.7.0.0.26-1.27.0.0

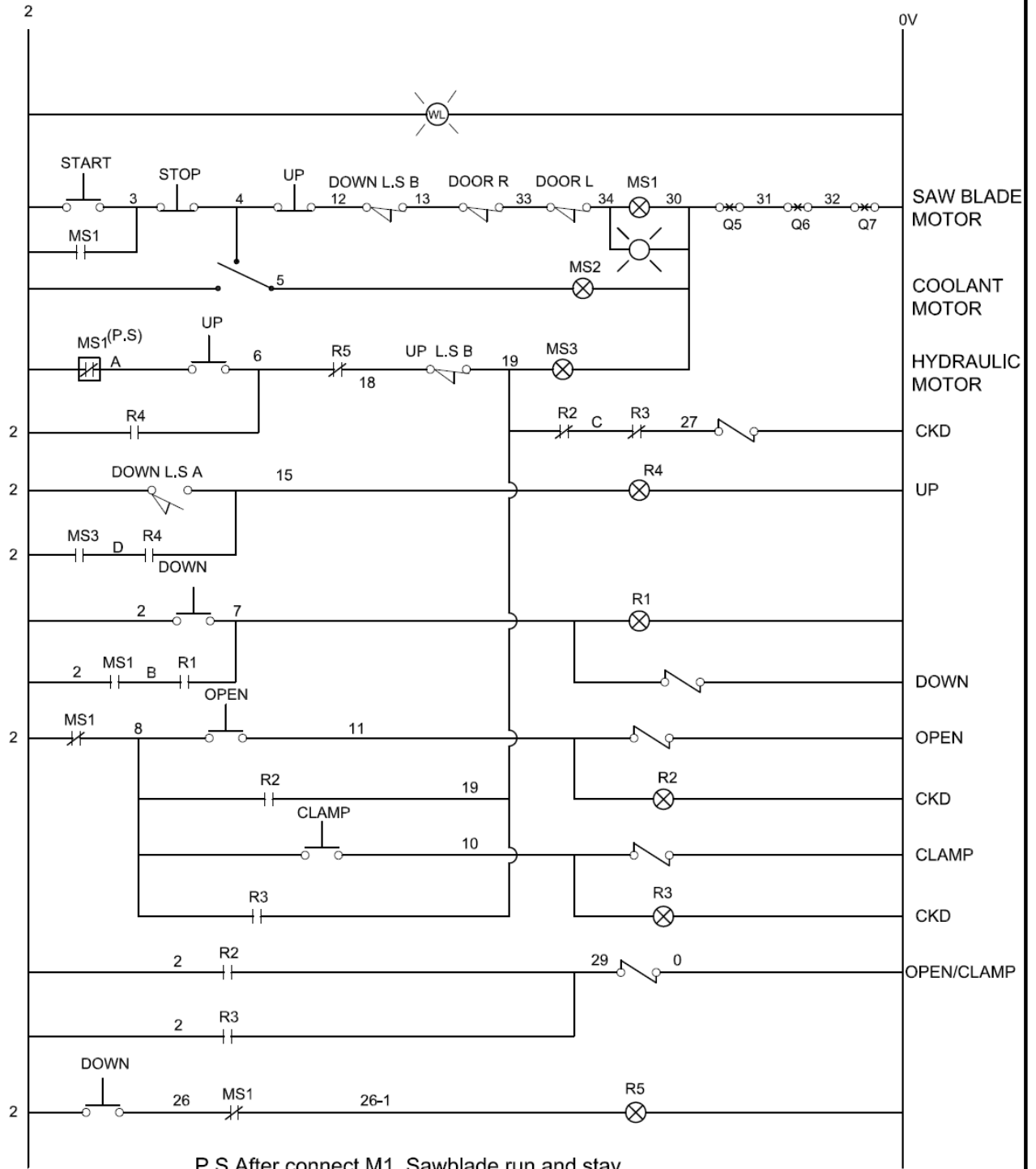

P.S After connect M1, Sawblade run and stay at the lowest position

WITH HYDRAULIC VISE

高聖精密機電股份有限公司 COSEN MECHATRONICS CO., LTD.	圖名	Circuit Board Layout1 線路板配置圖1	圖號	EL-SH250R (CE)	繪圖	鍾泓龍	日期	1030110	版本
					審核		日期		S0

Fig. 5-5 Circuit Board Layout 1 (CE model)

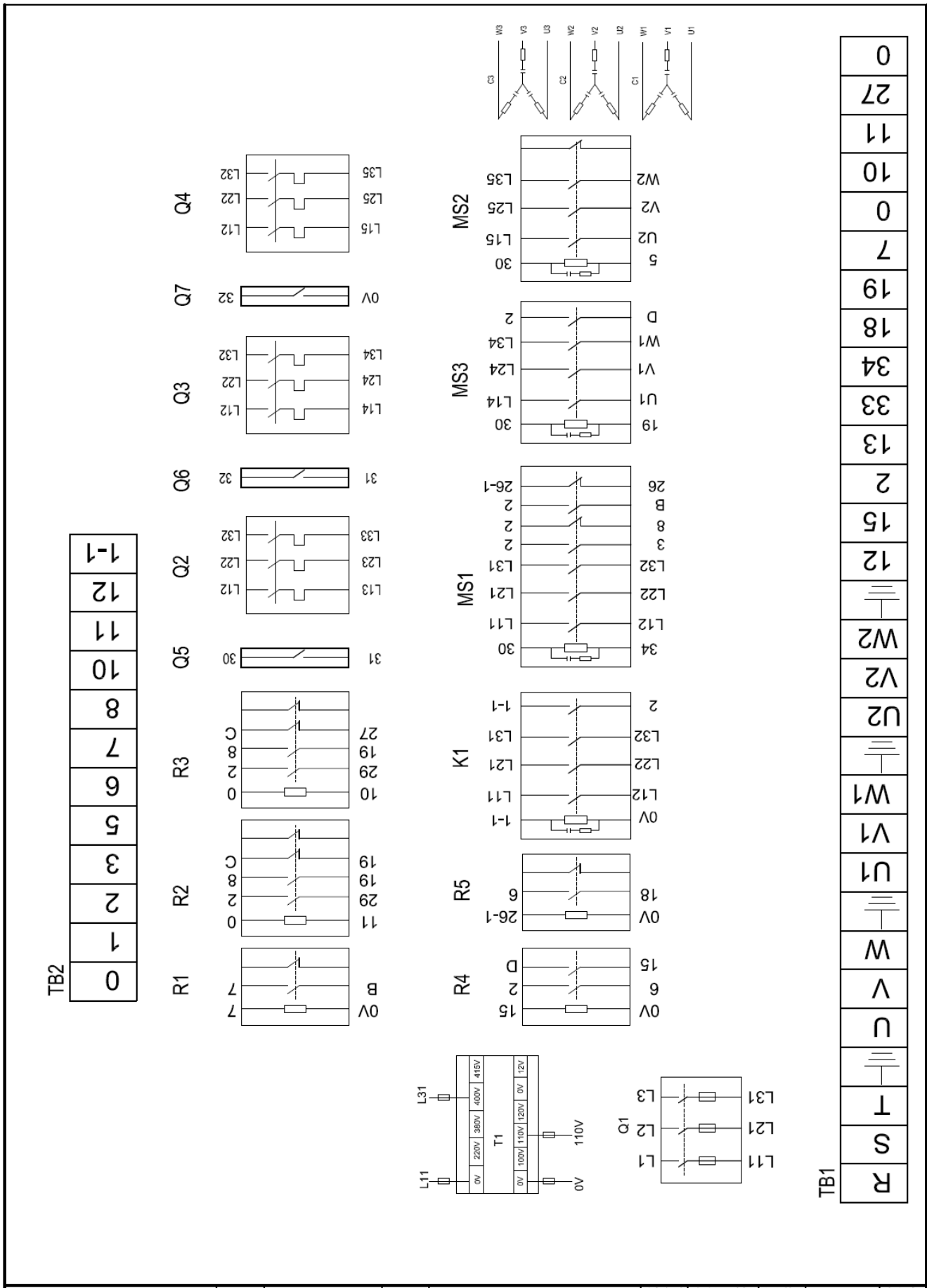

高聖精密機電股份有限公司 COSEN MECHATRONICS CO., LTD.	圖名	Circuit Board Layout2 線路板配置圖2	圖號	EL-SH250R (CE)	繪圖	鍾泓龍	日期	1030110	版本
					審核		日期		S0

Fig. 5-6 Circuit Board Layout 2 (CE model)

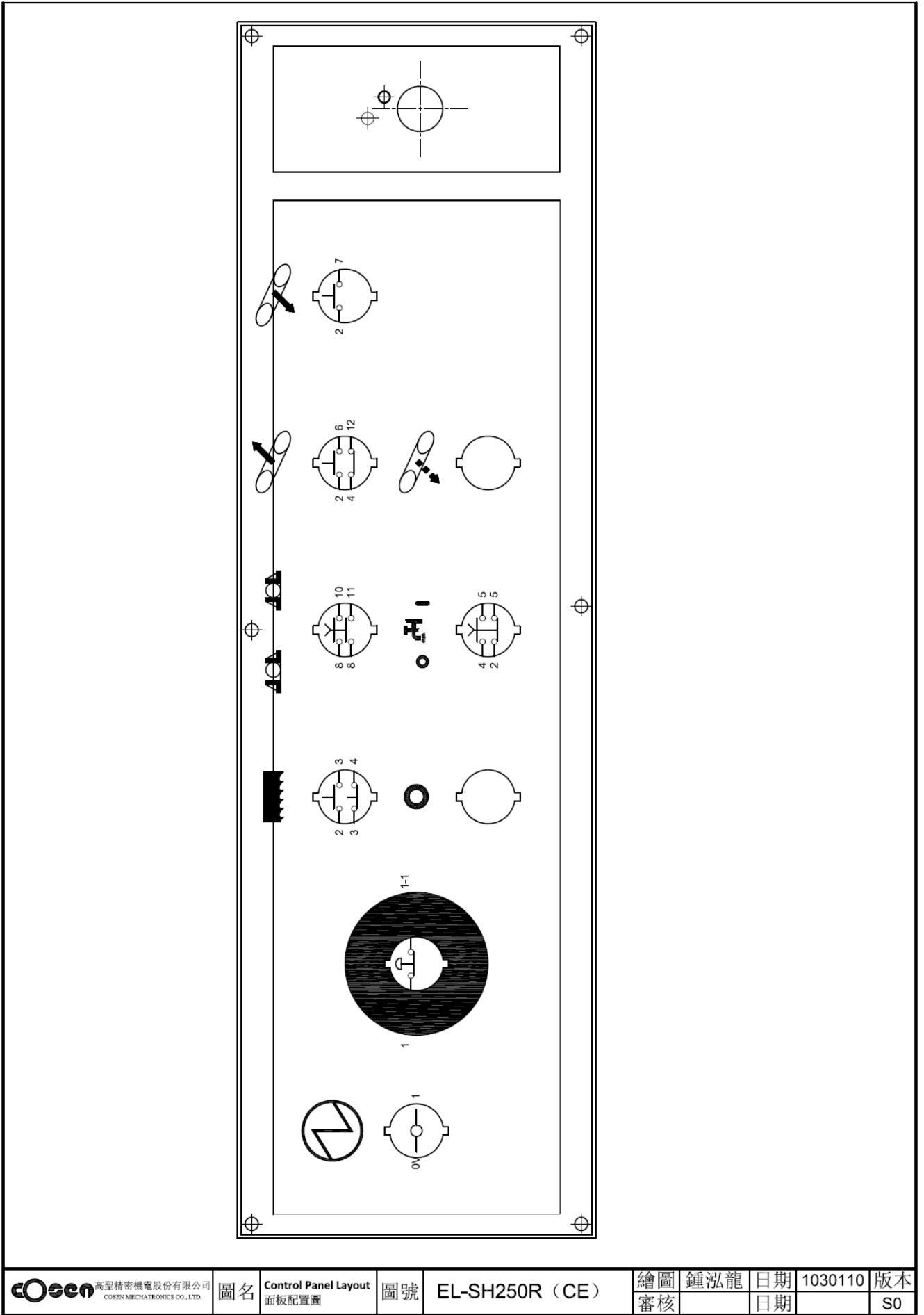

COSEN 高聖精密機電股份有限公司
COSEN MECHATRONICS CO., LTD.

圖名 Control Panel Layout
面板配置圖

圖號 EL-SH250R (CE)

繪圖	鍾泓龍	日期	1030110	版本
審核		日期		S0

Fig. 5-7 Control Panel Layout (CE model)

HYDRAULIC SYSTEM

HYDRAULIC CIRCUIT DIAGRAMS

COSEN

SH-250R HYDRAULIC CIRCUIT

HYDRAULIC CIRCUIT

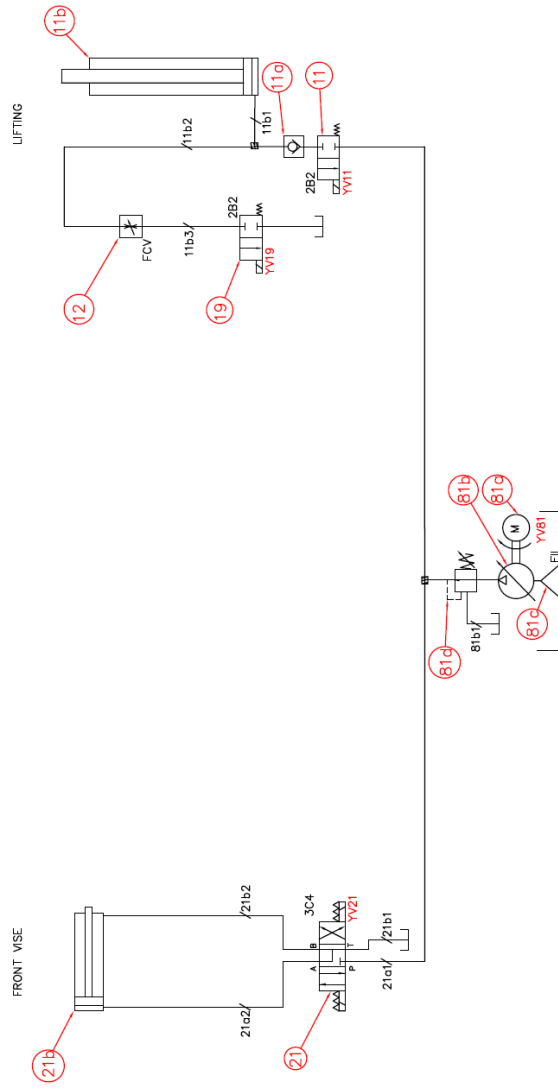

COSEN		COSEN MECHATRONICS CO., LTD.		DRAW		ANDY		NOTE	
SH-250R		HYDRAULIC CIRCUIT		CHECK		20140225			
DRAWING NO. SH-250R		HYDRA.DWG		APPROVED				DATE	
VERSION		1-0						NAME	

Fig. 6-1 Hydraulic circuit layout

BANDSAW CUTTING: A PRACTICAL GUIDE

INTRODUCTION

SAW BLADE SELECTION

SOME SAWING PRACTICES

CUTTING CONDITIONS SETTING

INTRODUCTION

Our bandsaw machines are designed to be installed with high quality using high speed saw blades for maximizing productivity. To be able to use this kind of high performance bandsaw blade, the machine has to be of rugged design, has high quality saw blade guides, has sufficient motor horse power for high saw band speeds, and has to be able to apply necessary tension to the saw bands. Your machine has all these features to provide a better service for you.

The saw blade is guided through the cutting area by roller guides to keep it straight as it comes off the driving wheels. The precision carbide inserted guides then hold the blade securely and accurately throughout the sawing process. The tension of the saw blade is adjusted through the tensioning device on the strong saw bow. The cutting feed and down feed pressure of the blade is regulated automatically by hydraulic regulation.

SAW BLADE SELECTION

The factors affecting cutting performance are:

- Type of material
- Material size and shape
- Guide spacing
- Blade selection
- Blade speed and feed
- Tooth form and spacing
- Blade tension
- Blade vibration
- Coolant

Material and its relation to the cutting rate



Fig. 7.1 Description of Band

- Depending on the hardness of the material the cutting rate will increase or decrease. For example, it takes more time to cut stainless steel than to cut cast iron.
- The surface conditions will also affect the cutting rate. If there are places on the surface on the material which are hard, a slower blade speed will be required or blade damage may result.
- It will be slower to cut tubing than to cut solids, because the blade must enter the material twice, and because coolant will not follow the blade as well.
- Tough or abrasive materials are much harder to cut than their machinability rating would indicate.
- Tooth spacing is determined by the hardness of the material and its thickness in cross section.
- Tooth set prevents the blade from binding in the cut. It may be either a "regular set" (also called a "raker set") or a "wavy set".
- The regular or raker set is most common and consists of a pattern of one tooth to the left, one tooth to the right, and one which is straight, or unset. This type of set is generally used where the material to be cut is uniform in size and for contour cutting.
- Wavy set has groups of teeth set alternately to right and left, forming a wave-like pattern. This reduces the stress on each individual tooth, making it suitable for cutting thin material or a variety of materials where blade changing is impractical. Wavy set is often used where tooth breakage is a problem. This is shown in Fig. 7.2 as follows:

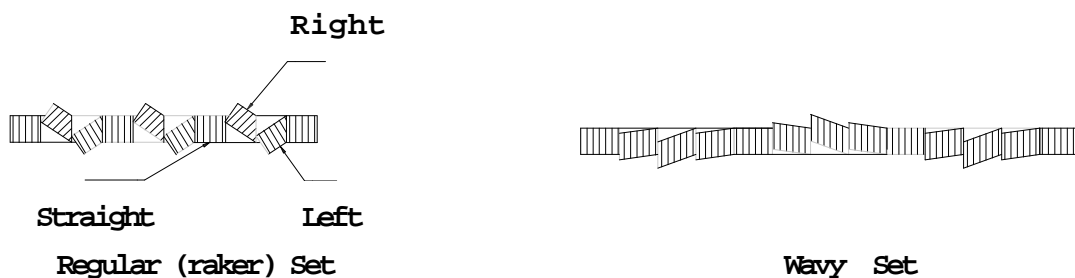

Fig. 7.2 The Saw Set

Material size and shape

The optimum material width for a band saw blade is 1 inch wide by 0.35 inch thick and is about 5 inches long. Below this width tooth loading may become excessive and the cutting rate must be reduced. Above this width blade control begins to be lost, as discussed below. Since the blade "sees" only that material it is cutting, the shape of the stock being cut will also affect cutting speeds, particularly if the piece is excessively wide or if it varies in the dimensions being cut.

Guide spacing

The rigidity of the blade is a function of guide spacing, with rigidity being reduced to the third power as the distance between the guides increases. For example, with guides spaced 2 inches apart, blade deflection might be approximately 0.2. Under the same conditions, but with the guides spaced at 4 inches apart, blade deflection would be approximately 0.8.

This is a much simplified version of the formula, because it does not consider band tension or guide design. It is important to recognize, for example that rollers are considered as a pivotal contact. Whereas carbide faces could be considered as anchored supports. A more complete deviation, including band tension and guide design, is included in Roark's handbook, "Formula for stress and strain".

Blade selection

There are different types of blades available. Please contact a bandsaw blade manufacturer for advice.

Blade speed and feed

Blade speed is generally limited by vibration and the ability to keep the blade sufficiently cool to avoid dulling the teeth. A blade which is running fast and taking a very light cut will dull quickly because the tips of the teeth will overheat from the rubbing action. If, however, we force the blade teeth deeper into the material, the blade will be less sensitive to heat, because the teeth are cutting more and rubbing less.

Tooth form and spacing

The selection of a tooth form generally is determined by the material to be cut. There are three general factors to consider: tooth form, style or shape of the teeth; tooth spacing, the number of teeth to the inch; and tooth set, which provides clearance for the body of the blade. Three styles of tooth are shown in Fig. 7.3 below:

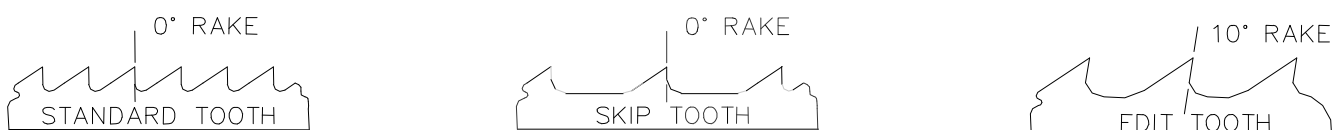

Fig. 7.3 Three Styles of Tooth

SOME SAWING PRACTICES

Saw Pitch Selection

Sawing “Rules of Thumb”:

1. The thinner the stock, the finer the saw pitch.
2. The thicker the stock, the coarser the saw pitch.
3. The more difficult the stock, the finer the saw pitch.
4. The softer the material , the coarser the saw pitch.

Always have at least three teeth in contact with the material being cut.

Material Size and Saw Pitch

Anytime during the cutting operation, at least three teeth must be in contact with the material being cut. Figure 7.4 shows some sawing practices:







SAWING PRACTICES	
CORRECT	INCORRECT
	
several teeth contact work	teeth strike sharp edge
	
Coarse teeth clear chips freely	Teeth too fine for large solids
	
Three or more teeth on cutting wall	Coarse teeth rip on thin wall

Fig. 7.4 Some sawing practices

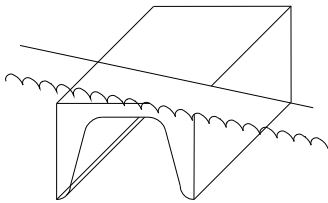
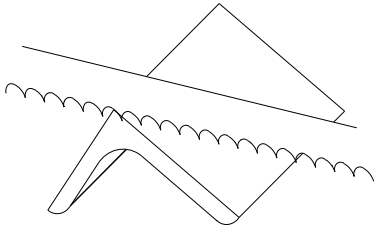
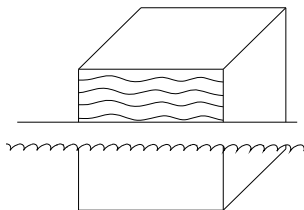
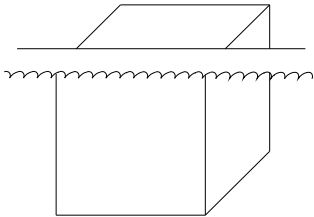
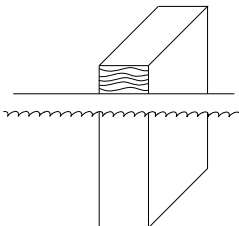
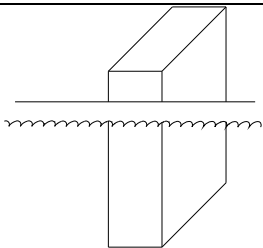
Solid Stock:

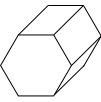
STYLE	up to 25 mm (1")	25-100mm (1-4")	100-250mm (4-10")
	8-10 TPI (Teeth per inch)	6-8 TPI	3-4 TPI
			
			

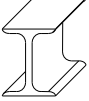
Structurals:

STYLE	up to 10 mm (3/8")	10-20mm (3/8-3/4")	above 20mm (3/4")
	10-8 TPI	8-10 TPI	6-8 TPI
			
			

Solid Bundle:

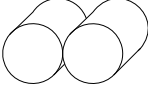
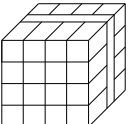
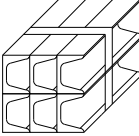
STYLE	up to 20 mm (3/4")	20-80mm (3/4-3 1/4")	above 80mm (3 1/4")
	8 - 10 TPI	2 - 8 TPI	4 - 6 TPI
			
			

MAINTENANCE & SERVICE

INTRODUCTION

BASIC MAINTENANCE

MAINTENANCE SCHEDULE

BEFORE BEGINNING A DAY'S WORK

AFTER ENDING A DAY'S WORK

EVERY MONTH

EVERY THREE MONTHS

EVERY SIX MONTHS

STORAGE CONDITIONS

TERMINATING THE USE OF MACHINE

OIL RECOMMENDATION FOR MAINTENANCE

INTRODUCTION

For the best performance and longer life of the band saw machine, a maintenance schedule is necessary. Some of the daily maintenance usually takes just a little time but will give remarkable results for the efficient and proper operation of cutting.

BASIC MAINTENANCE

It is always easy and takes just a little effort to do the basic maintenance. But it always turns out to be a very essential process to assure the long life and efficient operation of the machine. Most of the basic maintenance requires the operator to perform it regularly.

MAINTENANCE SCHEDULE

We suggest you do the maintenance on schedule. The recommended schedule includes three periods,

1. Daily maintenance. 2. Monthly maintenance. 3. Six months maintenance.

Before beginning a day's work

1. Please check the hydraulic oil level. If oil level volume is below 1/2, please add oil as necessary. (Filling up to 2/3 level is better for system operation.)
2. Please check the cutting fluid level, adding fluid as necessary. If the fluid appears contaminated or deteriorated, drain and replace it.
3. Please check the saw blade to ensure that it is properly positioned on both the drive and idle wheels.
4. Please make sure that the saw blade is properly clamped by the left and right inserts.
5. Please check the wire brush for proper contact with the saw blade. Replace the wire brush if it is worn out.

After ending a day's work

Please remove saw chips and clean the machine with discharging the cutting fluid when work has been completed.



Do not discharge cutting fluid while the saw blade is operating because it will cause severe injury on operator's hand.



Be sure the saw blade is fully stop, it will be performed after working inspection.

Every month

Please apply grease to the following points:

1. Idle wheel
2. Drive wheel
3. Blade tension device

Recommended Grease:

- Shell Alvania EP Grease 2
- Mobil Mobilplex 48

Every three months

Replace the transmission oil after operating for three months (or 600 hours).

Recommended Grease:

- Shell Alvania EP Grease 2
- Mobil Mobilplex 48 (600W Cylinder oil)

Every six months

1. Clean the filter of the cutting fluid.
2. Replace the transmission oil for every half of a year (or 1200 hours).
Check the sight gauge to ascertain the transmission level.

Recommended TRANSMISSION OIL

- Omala oil HD220
- Mobil comp 632 600W Cylinder oil

3. Replace the hydraulic oil.

Recommended HYDRAULIC OIL

- Shell Tellus 27
- Mobil DTE OIL light Hydraulic 28

STORAGE CONDITIONS

Generally, this machine will be stored on the following conditions in future:

- (1) Turn off the power.
- (2) Ambient temperature: 5°C ~ 40°C
- (3) Relative humidity: 30%~95% (without condensation)
- (4) Atmosphere: use a plastic canvas to cover machine to avoid excessive dust, acid fume, corrosive gases and salt.
- (5) Avoid exposing to direct sunlight or heat rays which can change the environmental temperature.
- (6) Avoid exposing to abnormal vibration.
- (7) Must be connected to earth.

TERMINATING THE USE OF THE MACHINE

Waste disposal:

When your machine can not work anymore, you should leak out the oil from machine body. Please storage the oil in safe place with bottom. Ask a environment specialist to handle the oil. It can avoid soil pollution. The oil list in machine:

- Hydraulic oil
- Cutting fluid
- Drive wheel gear oil

OIL RECOMMENDATION FOR MAINTENANCE

Item	Method	Revolution	Suggest oil
Dovetail guide	Keep grease covered. Antirust.	Daily	Shell R2
Roller bearing	Sweep clean and oil with lubricant.	Daily	SEA #10
Bed roller / surface	Sweep clean and oil with lubricant.	Daily	SEA #10
Nipples of bearing	Use grease gun, but not excess.	Monthly	Shell R2
Blade tension device	Use grease gun, but not excess.	Monthly	Shell R2
Reducer	Inspect once a week. Change oil of 600 hours of using. Change it every year.	Regularly	Omala oil HD220 Mobil Gear 630
Hydraulic system	Inspect half a year. Change oil every year.	Regularly	Shell Tellus 32 Mobil DTE oil Light Hydraulic 24
Bearing	Inserts	Oil with lubricant, but not excess.	Daily
	Band wheel	Oil with lubricant, but not excess.	Weekly
	Cylinder	Oil with lubricant, but not excess.	6 Monthly
	Wire brush	Oil with lubricant, but not excess.	6 Monthly



- 1. Turn off the stop circuit breaker switch before servicing the machine.**
- 2. Then post a sign to inform people that the machine is under maintenance.**
- 3. Drain all of the cutting fluid and oil off and carefully treat them to avoid pollution.**

TROUBLESHOOTING

INTRODUCTION

PRECAUTIONS

GENERAL TROUBLES & SOLUTIONS

MINOR TROUBLES & SOLUTIONS

MOTOR TROUBLES & SOLUTIONS

BLADE TROUBLES & SOLUTIONS

SAWING PROBLEMS & SOLUTIONS

RE-ADJUSTING THE ROLLER TABLE

INTRODUCTION

All the machines manufactured by COSEN pass a 72 hours continuously running test before shipping out and COSEN is responsible for the after sales service problems during the warranty period if the machines are used normally. However, there still exist the some unpredictable problems which may disable the machine from operating.

Generally speaking, the system troubles in this machine model can be classified into three types, namely GENERAL TROUBLES, MOTOR TROUBLES and BLADE TROUBLES. Although you may have other troubles which can not be recognized in advance, such as malfunctions due to the limited life-span of mechanical, electric or hydraulic parts of the machine.

COSEN has accumulated enough experiences and technical data to handle all of the regular system troubles. Meanwhile, the engineering department of COSEN had been continuously improving the machines to prevent all possible troubles.

It is hoped that you will give COSEN your maintenance experience and ideas so that both sides can achieve the best performance.

PRECAUTIONS

When an abnormality occurs in the machine during operation, you can do it yourself safely. If you have to stop machine motion immediately for parts exchanging, you should do so according to the following procedures:

- Press HYDRAULIC MOTOR OFF button or EMERGENCY STOP button.
- Open the electrical enclosure door.
- Turn off breaker.



BEFORE ANY ADJUSTMENT OR MAINTENANCE OF THE MACHINE, PLEASE MAKE SURE TO TURN OFF THE MACHINE AND DISCONNECT THE POWER SUPPLY.

GENERAL TROUBLES AND SOLUTIONS



DISCONNECT POWER CORD TO MOTOR BEFORE ATTEMPTING ANY REPAIR OR INSPECTION.

TROUBLE	PROBABLE CAUSE	SUGGESTED REMEDY
Motor stalls	Excessive belt tension	Adjust belt tension so that belt does not slip on drive pulley while cutting (1/2" Min. deflection of belt under moderate pressure.)
	Excessive head pressure	Reduce head pressure. Refer to Operating Instructions "Adjusting Feed".
	Excessive blade speed	Refer to Operating Instructions "Speed Selection".
	Improper blade selection	Refer to Operating Instructions "Blade Selection".
Cannot make square cut	Dull blade	Replace blade.
	Guide rollers not adjusted properly	Refer to Adjustments.
	Rear vise jaw not adjusted properly	Set fixed vise jaw 90° to blade.
	Excessive head pressure	Reduce head pressure. Refer to operating instructions "Adjusting Feed."
Increased cutting time	Dull blade	Replace blade
	Insufficient head pressure	Increase head pressure. Refer to Operating Instructions "Adjusting Feed."
	Reduce blade speed	Refer to Operating Instructions "Speed Selection."
Will not cut	Motor running in wrong direction	Reverse rotation of motor. (Motor rotation C.C.W. pulley end.)
	Blade teeth pointing in wrong direction	Remove blade, turn blade inside out. Re-install blade. (Teeth must point in direction of travel.)
	Hardened material	Use special alloy blades. (Consult your industrial distributor for recommendation on type of blade required.)

MINOR TROUBLES & SOLUTIONS

TROUBLE	PROBABLE CAUSE	SUGGESTED REMEDY
Saw blade motor does not run even though blade drive button is pressed.	Overload relay activated	Reset
	Saw blade is not at forward limit position.	Press SAW FRAME FORWARD button

MOTOR TROUBLES & SOLUTIONS

TROUBLE	PROBABLE CAUSE	SUGGESTED REMEDY
Motor will not start	Magnetic switch open, or protector open.	Reset protector by pushing red button (inside electric box.)
	Low voltage	Check power line for proper voltage.
	Open circuit in motor or loose connections.	Inspect all lead terminations on motor for loose or open connections.
Motor will not start, fuse or circuit breakers "blow".	Short circuit in line, cord or plug.	Inspect line, cord and plug for damaged insulation and shorted wire.
	Short circuit in motor or loose connections	Inspect all lead terminations on motor for loose or shorted terminals or worn insulation on wires.
	Incorrect fuses or circuit breakers in power line.	Install correct fuses or circuit breakers.
Motor fail to develop full power. (Power output of motor decreases rapidly with decrease in voltage at motor terminals.)	Power line overloaded with lights, appliances and other motors.	Reduce the load on the power line.
	Undersize wires or circuit too long.	Increase wire sizes, or reduce length of wiring
	General overloading of power company's facilities.	Request a voltage check from the power company
Motor overheat	Motor overloaded.	Reduce load on motor
	Air circulation through the motor restricted.	Clean out motor to provide normal air circulation through motor.
Motor stalls (Resulting in blown fuses or tripped circuit breakers)	Short circuit in motor or loose connections.	Inspect terminals in motor for loose or shorted terminals or worn insulation on lead wires.
	Low voltage	Correct the low line voltage conditions.
	Incorrect fuses or circuit breakers in power line.	Install correct fuses circuit breakers.
	Motor overloaded	Reduce motor load.
Frequent opening of fuses or circuit breakers.	Motor overloaded	Reduce motor load
	Incorrect fuses or circuit breakers.	Install correct fuses or circuit breakers.

BLADE TROUBLES AND SOLUTIONS



DISCONNECT POWER CORD TO MOTOR BEFORE ATTEMPTING ANY REPAIR OR INSPECTION.

TROUBLE	PROBABLE CAUSE	SUGGESTED REMEDY
Teeth strippage	Too few teeth per inch	Use finer tooth blade
	Loading of gullets	Use coarse tooth blade or cutting lubricant.
	Excessive feed	Decrease feed
	Work not secured in vise	Clamp material securely
Blade breakage	Teeth too coarse	Use a finer tooth blade
	Misalignment of guides	Adjust saw guides
	Dry cutting	Use cutting lubricant
	Excessive speed	Lower speed. See Operating Instructions "Speed selection."
	Excessive speed	Reduce feed pressure. Refer to Operating Instructions "Adjusting Feed."
	Excessive tension	Tension blade to prevent slippage on drive wheel while cutting.
Blade line Run-out or Run-in	Wheels out of line	Adjust wheels
	Guides out of line	For a straight and true cut, realign guides, check bearings for wear.
	Excessive pressure	Conservative pressure assures long blade life and clean straight cuts.
	Support of blade insufficient	Move saw guides as close to work as possible.
	Material not properly secured in vise	Clamp material in vise, level and securely.
Blade twisting	Blade tension improper	Loosen or tighten tension on blade.
	Blade not in line with guide bearings	Check bearings for wear and alignment.
	Excessive blade pressure	Decrease pressure and blade tension
Premature tooth wear	Blade binding in cut	Decrease feed pressure
	Dry cutting	Use lubricant on all materials, except cast iron
	Blade too coarse	Use finer tooth blade
	Not enough feed	Increase feed so that blade does not ride in cut
	Excessive speed	Decrease speed

SAWING PROBLEMS AND SOLUTIONS

Other than this manual, the manufacturer also provides some related technical documents listed as follows:

Sawing Problems and Solutions

					Vibration during cutting	Failure to cut	Short life of saw blade	Curved cutting	Broken blade		
✓	✓	✓	✓	✓						Use of blade with incorrect pitch	Use blade with correct pitch suited to workpiece width
✓	✓	✓	✓	✓						Failure to break-in saw blade	Perform break-in operation
✓	✓	✓								Excessive saw blade speed	Reduce speed
			✓	✓						Insufficient saw blade speed	Increase speed
✓		✓	✓	✓						Excessive saw head descending speed	Reduce speed
✓		✓	✓							Insufficient saw head descending speed	Increase speed
		✓	✓							Insufficient saw blade tension	Increase tension
✓		✓	✓	✓						Wire brush improperly positioned	Relocate
✓		✓	✓							Blade improperly clamped by insert	Check and correct
✓	✓	✓	✓	✓						Improperly clamped workpiece	Check and correct
	✓	✓	✓							Excessively hard material surface	Soften material surface
		✓	✓	✓						Excessive cutting rate	Reduce cutting rate
	✓	✓								Non-annealed workpiece	Replace with suitable workpiece
✓		✓	✓	✓						Insufficient or lean cutting fluid	Add fluid or replace
✓		✓	✓	✓						Vibration near machine	Relocate machine
		✓	✓							Non-water soluble cutting fluid used	Replace
✓		✓	✓							Air in cylinder	Bleed air
✓		✓		✓						Broken back-up roller	Replace
✓	✓	✓	✓	✓						Use of non-specified saw blade	Replace
✓	✓	✓	✓	✓						Fluctuation of line voltage	Stabilize
✓		✓	✓							Adjustable blade guide too far from workpiece	Bring blade guide close to workpiece
✓		✓	✓	✓						Loose blade guide	Tighten
		✓		✓						Blue or purple saw chips	Reduce cutting rate
✓		✓		✓						Accumulation of chips at inserts	Clean
	✓									Reverse positioning of blade on machine	Reinstall
✓		✓	✓							Workpieces are not bundled properly	Re-bundle
✓		✓		✓						Back edge of blade touching wheel flange	Adjust wheel to obtain clearance
✓	✓	✓								Workpiece of insufficient diameter	Use other machine, suited for diameter of workpiece
	✓	✓	✓							Saw blade teeth worn	Replace

RE-ADJUSTING THE ROLLER TABLE

If the feeding table suffers the huge stroke and the alignment is effected, follow the below procedure to adjust.

TOOL, measuring

Measurement, Horizontal balance

Procedure

1. Screw or loosen the adjusting bolt to attain the horizontal balance (leveling) between the roller table and the machine frame.
2. Ensure that the machine frame is not struck by the loaded material on the feeding table.
3. Check the leveling by the measuring tool.
4. After finished the adjusting, fix the roller table.



If the feeding table and the machine frame are not positioned under the horizontal balance, the loaded material may be going up gradually and affect the cutting effect.

Warranty

Warranty

New machines are warranted to be free from defects in workmanship and material for a period of one (1) year from the date of shipment by Seller. The warranty period is based on normal usage of two thousand eighty hours (2080) per year and is reduced proportionately for any excess usage. Products, which under normal operating conditions in Buyer's plant are defective in workmanship or material, will be repaired or replaced at the option of Seller.

This warranty does not cover shipping freight charges for either the return of the defective part or for the shipping of the replacement or repaired part.

Seller will have no obligation to repair or replace perishable parts, or materials or parts damaged by misuse, negligence or failure of Buyer to provide appropriate maintenance and service as stated in the operator's manual or industry standard and normally acceptable practices.

This warranty does not apply if the machine has been altered or modified without our prior written consent.

In the case of components or units purchased by Seller including work holding devices, tool holders, motors and controls, the warranty shall not exceed that received by Seller from the supplier of such components or units.

Seller will not assume responsibility for products or components returned to Seller without prior consent or for unauthorized repairs to its products, even though defective.

Electrical Equipment: The warranty available for all electrical components to the Buyer will be voided if the voltage supplied to the machine is found to be outside the stated voltage of the machine by +/- 10% and/or grounded at machine.

Accessories Supplied with Manufacturer's Equipment: The warranties available to the Buyer are those extended by the accessory manufacturer, if any, to the extent they are in force and effect. The ACCESSORY MANUFACTURER'S WARRANTY, if any, is exclusive and is in lieu of all other warranties whether written, oral or implied.

PARTS

SPARE PARTS RECOMMENDATIONS

PART LIST

SPARE PARTS RECOMMENDATIONS

The following table lists the common spare parts we suggest you purchase in advance:

Part Name	Part Name
Saw blade	Coolant tank filter
Wire brush	Steel plates
Carbide inserts	Rollers
Bearings	Belt
Hydraulic tank leak-proof asbestos	Duster seal
Rubber washer	Snap ring
Oil seal	O-ring

S250R-10000 底座組 Base Assembly

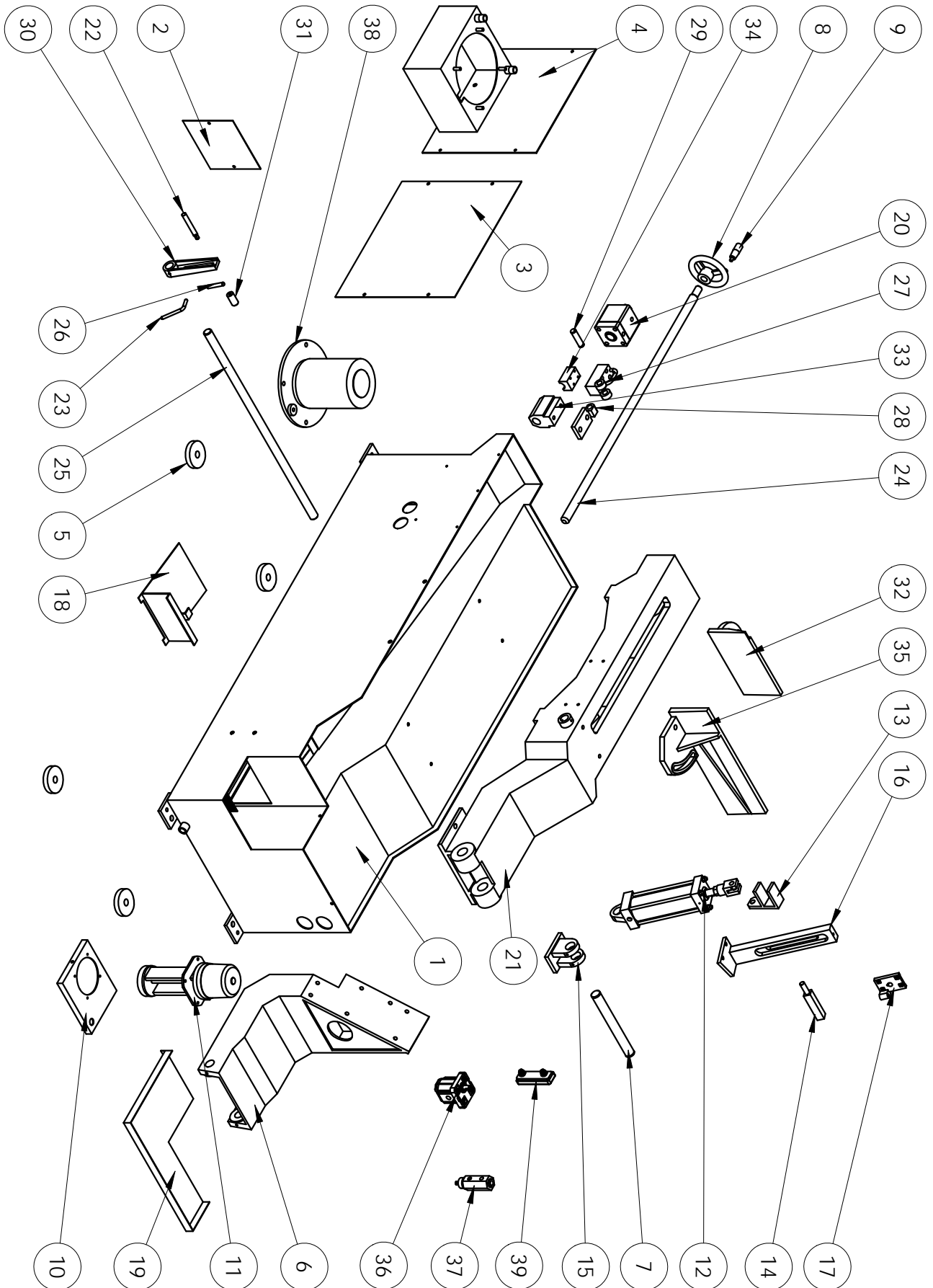



S250R-10000 底座組 Base Assembly

ITEM	PART NO.	PART NAME	PART NAME IN CHINESE	PART SPEC.	QTY
1	R1010-1001	base	底座		1
2	AJC-7025	base side cover	底座側蓋		1
3	R1010-1071	rear cover	後蓋		1
4	SJY-2105A	oil tank	油壓箱		1
5	AHR-1055	table stand pad	底座墊塊		4
6	R1010-1151A	joint seat	關節座		1
7	MJA-1008B	joint shaft	關節軸		1
8	PP-52020	handwheel	手輪		1
9	PP-52030	handwheel handle	手柄輪		1
10	AJC-7024	coolant pump fixed plate	水幫固定蓋		1
11	PP-32051-CE	coolant pump	浸水幫浦		1
12	SJM-4026	saw bow cylinder	鋸弓油壓缸		1
13	R1010-3275	saw bow cylinder ear	鋸弓油缸上耳		1
14	SJM-4028	cylinder fixed pin	油壓缸固定銷		1
15	R1010-3271	cylinder fixed seat	油缸固定座		1
16	SJM-4044	limit switch sliding plate	限動開關滑板		1
17	SJY-1131	limit switch sliding seat	限動開關滑座		1
18	R1010-1001-3	splash shield	擋水板		1
19	R1010-1043	catchment plate	底座集水板		1
20	S460D-23000	vise cylinder assembly	虎鉗油壓缸組		1
21	S250R-2001A	bed	床面		1
22	MAE-1051	stopper	定寸檔桿		1
23	MAE-2007	adjusting rod handle	調整桿把手		1
24	MJA-1014	lead screw	導螺桿		1
25	MJA-1024	depth bar	定寸桿		1
26	MJA-1026	fixed rod	固定桿		1
27	MJA-1061	vise pawl	快速虎鉗施力板		1
28	MJA-1062	pawl swival arm	施力板轉座		1
29	MJA-1063	pawl swival shaft	施力板轉軸		1
30	MJA-1031	stopper bracket	定寸滑塊		1
31	MJA-1025	stopper fastening bolt	固定螺帽		1
32	MJA-1010	movable vise	活動夾板		1
33	MJA-1058A	vise sliding block	夾板滑塊		1
34	MJA-1054B	screw shaft nut	螺桿螺母		1
35	MJA-1011	fixed vise	固定夾板		1
36	PP-32202	hydraulic pump	油壓幫浦		1
37	ACA-10100	pressure valve assembly	洩壓閥整組		1
38	PP-31313	hydraulic motor	油壓馬達		1
39	PP-21030	oli gauge	油面計(含刻度表)	3"	1

S250R-30000 鋸弓組 Saw Bow Assembly

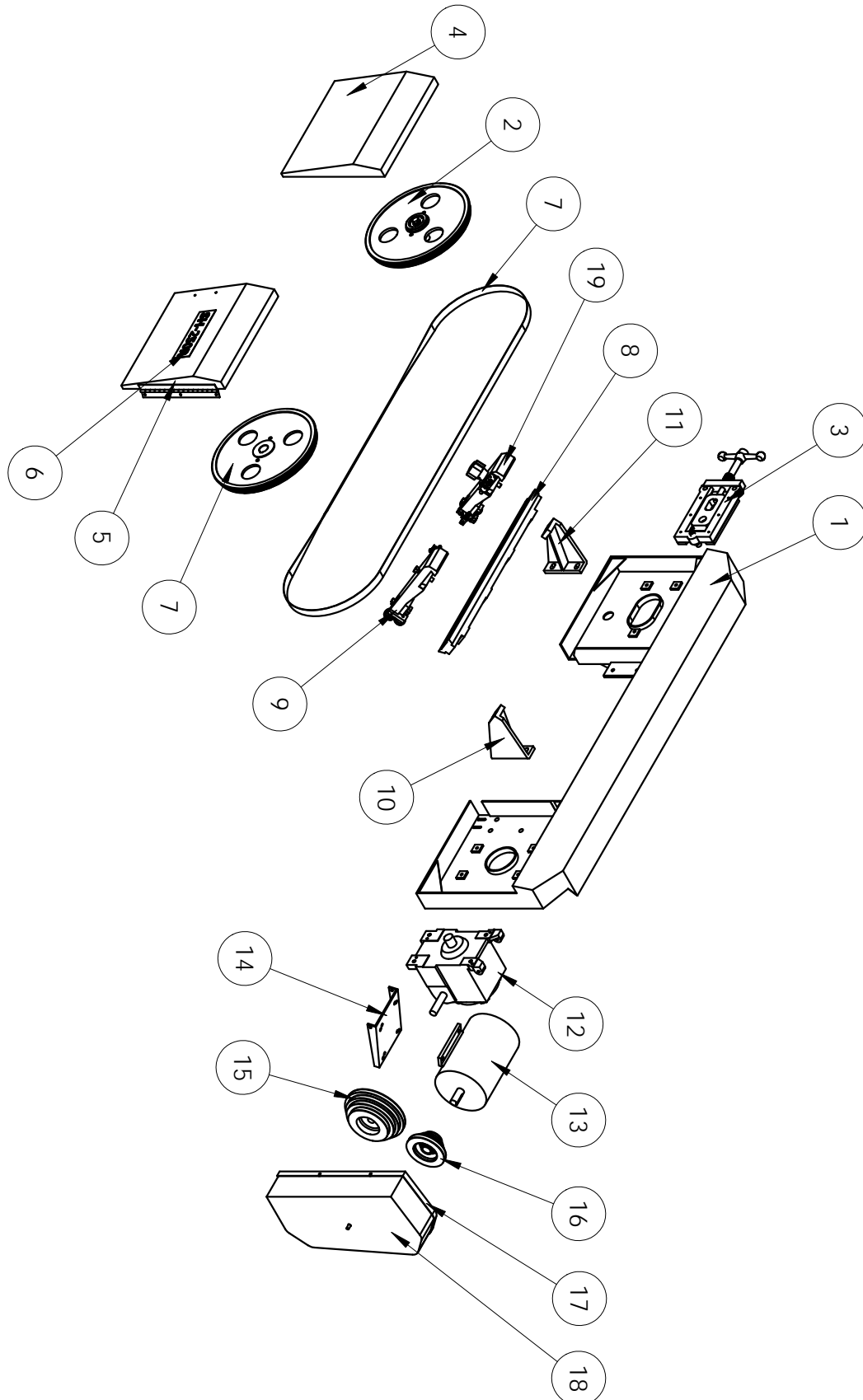

S250R-30000 鋸弓組 Saw Bow Assembly

ITEM	PART NO.	PART NAME	PART NAME IN CHINESE	PART SPEC.	QTY
1	AJC-3001	saw bow	鋸弓		1
2	SJY-1113	idle wheel	上輪		1
3	SJY-11029	blade tension adjustment device	張力調整組		1
4	AJC-3003	idle wheel cover	上輪箱蓋		1
5	AJC-3004	driving wheel cover	下輪箱蓋		1
6	S250R-3097A	model plate	機型銘牌		1
7	PP-18141	saw blade	鋸帶		1
8	SJY-1105	guide arm sliding plate	鋸臂滑板		1
9	SYM-8006	right guide arm	右鋸臂		1
10	SYM-5003	dovetail slide seat (left)	鳩尾槽固定座(左)		1
11	SYM-5004	dovetail slide seat (right)	鳩尾槽固定座(右)		1
12	PP-16022	gear reducer	減速機		1
13	PP-31042	motor	馬達		1
14	MJA-2067	motor plate	馬達底板		1
15	MJA-2011C	transmission pulley	減速機皮帶輪		1
16	SJY-1119	motor belt pulley	馬達皮帶輪		1
17	S250R-3071	pulley cover	普利護蓋(一)		1
18	S250R-3071A	pulley cover	普利護蓋(二)		1
19	SYM-8005	left guide arm	左鋸臂		1

S250R-30300 上輪組 Idle Wheel Assembly

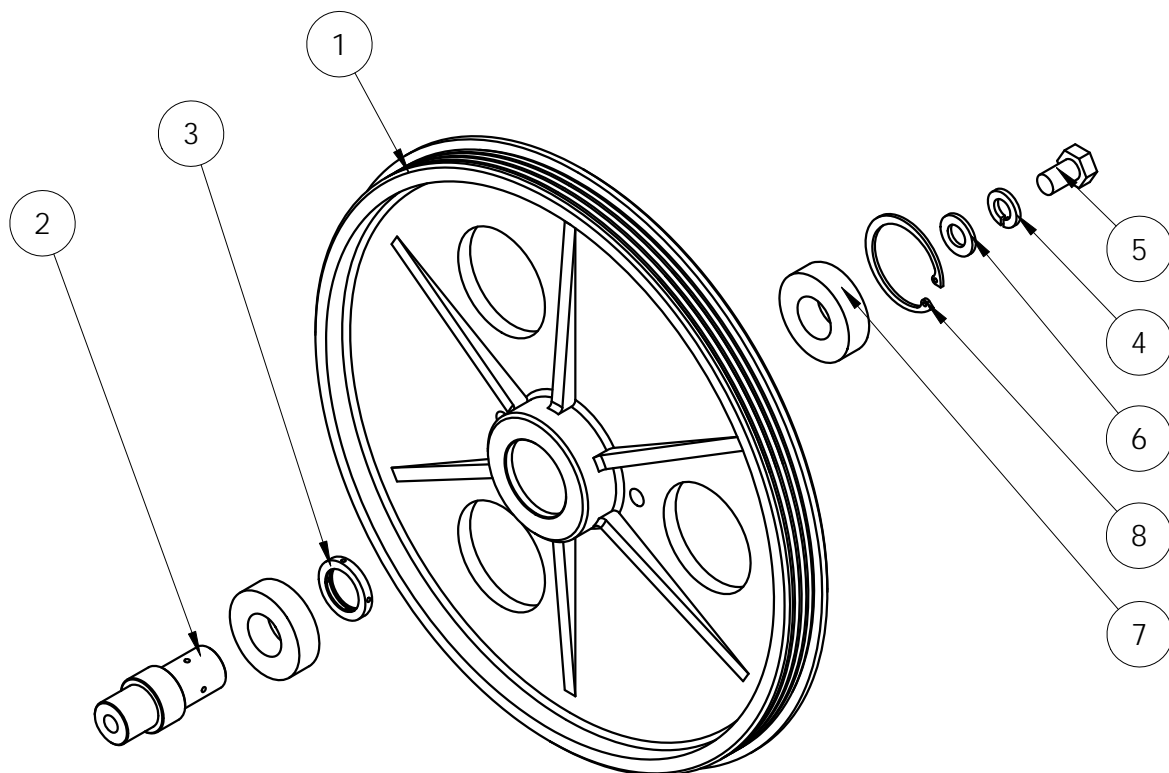

ITEM	PART NO.	PART NAME	PART NAME IN CHINESE	PART SPEC.	QTY
1	SJY-1113	Idle wheel	上輪		1
2	SJY-1114	Idle wheel shaft	上輪軸		1
3	MAE-2025	Bearing washer	上輪軸墊圈		1
4	PQA-12A	spring washer	彈簧華司	φ12 mm	1
5	PLA-12-20	Hexagon bolt	外六角頭螺絲	M12xP1.75x20	1
6	PPA-12	Flat washer	平面華司(公)	φ12 mm	1
7	PP-14130	Bearing	軸承		2
8	PP-58107	Snap ring	內鎖扣環	R52	1

S250R-31000 鋸臂組 Saw Arm Assembly

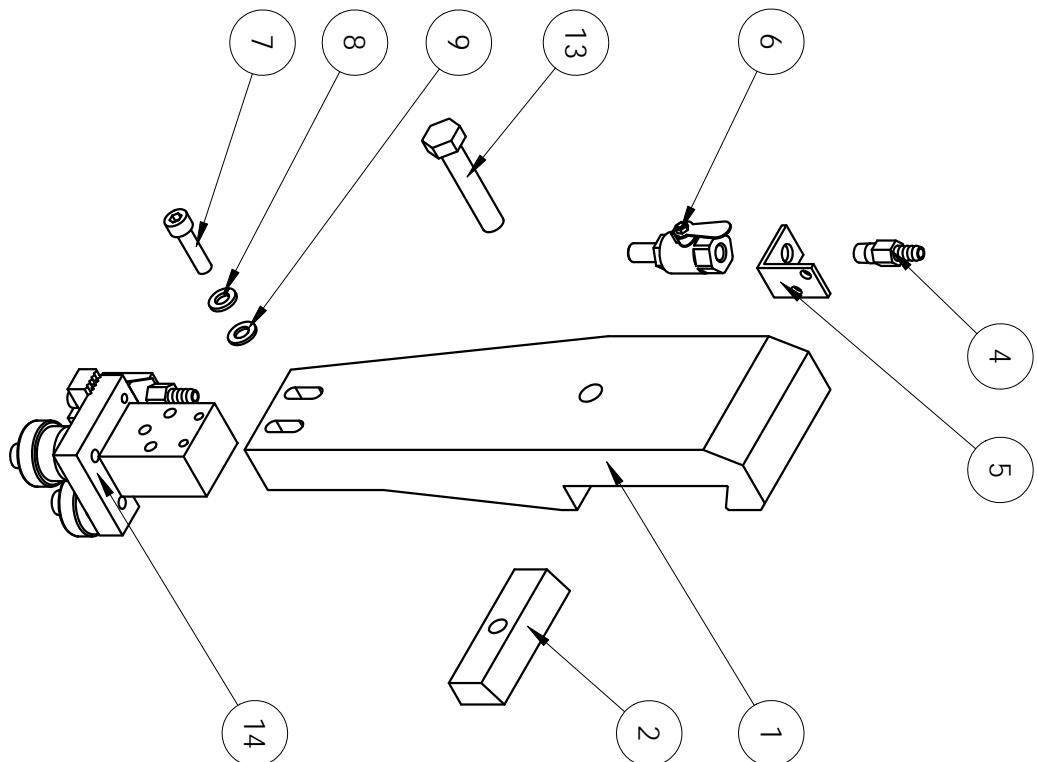
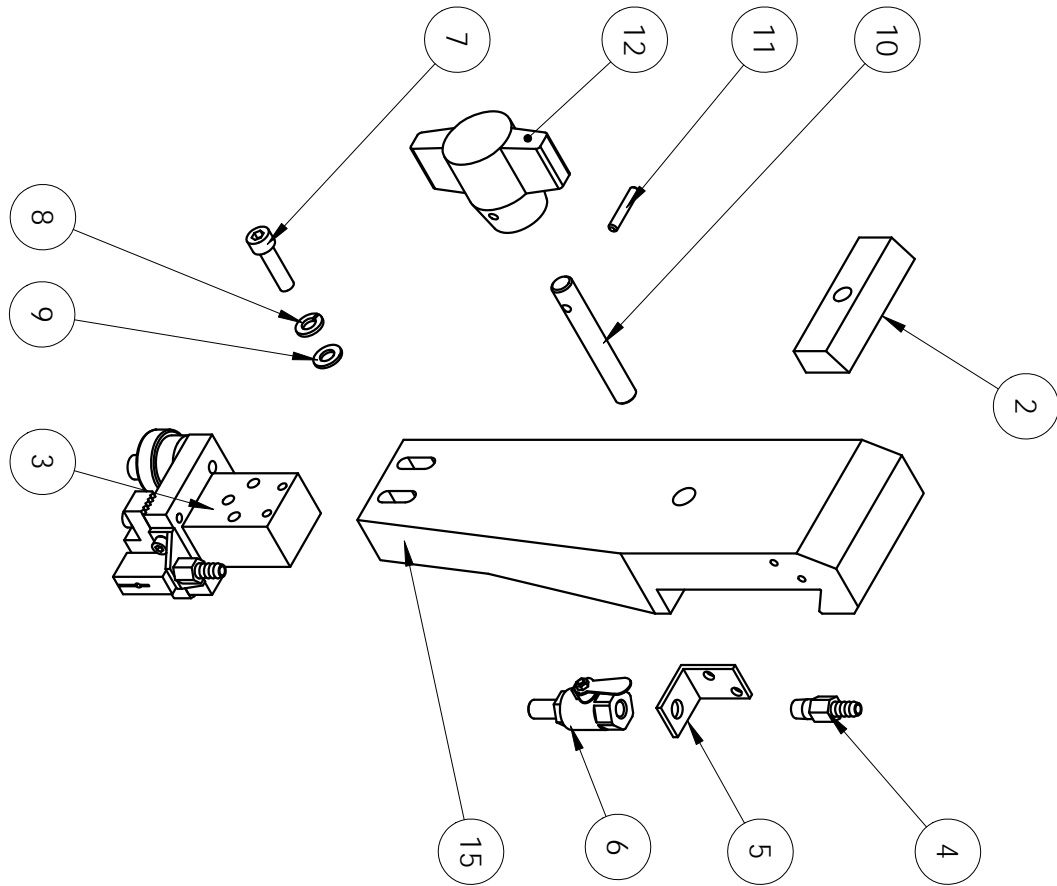

S250R-31000 鋸臂組 Saw Arm Assembly

ITEM	PART NO.	PART NAME	PART NAME IN CHINESE	PART SPEC.	QTY
15	SYM-8006	left guide arm	右鋸臂		1
2	MJA-2032	guide arm fixed block	鋸臂固定塊		2
3	M916J-31300	left guide roller assembly	左導輪座組		1
4	MJA-2043	coolant fitting	水管接頭		2
5	MJA-2041	Faucet base plate	水龍頭座板	∅ 8 mm	2
6	PP-43132	on/off valve	開關閥(無頭)	孔位1/8"牙	2
7	PBA-8-30	Hex soc cap screw	有頭內六角螺絲(公)		2
8	PQA-8	Spring washer	彈簧華司(公)	∅ 8 mm	2
9	PPA-8	Washer	平面華司(公)	∅ 8 mm	2
10	MJA-2031B	screw	鋸臂把手螺絲根(鐵)		1
11	PRA-5-30	spring pin	彈簧銷	SPP-5 x 30 mm	1
12	AHA-0726	Saw arm handle	鋸臂把手	M12xP1.75x60	1
13	PQA-12	spring washer	彈簧華司	∅ 12 mm	1
14	M916J-31600	right guide roller assembly	右導輪座組		1
15	SYM-8005	Left guide arm	左鋸臂		1

S250R-22000 固定虎鉗組 Fixed Vise Assembly

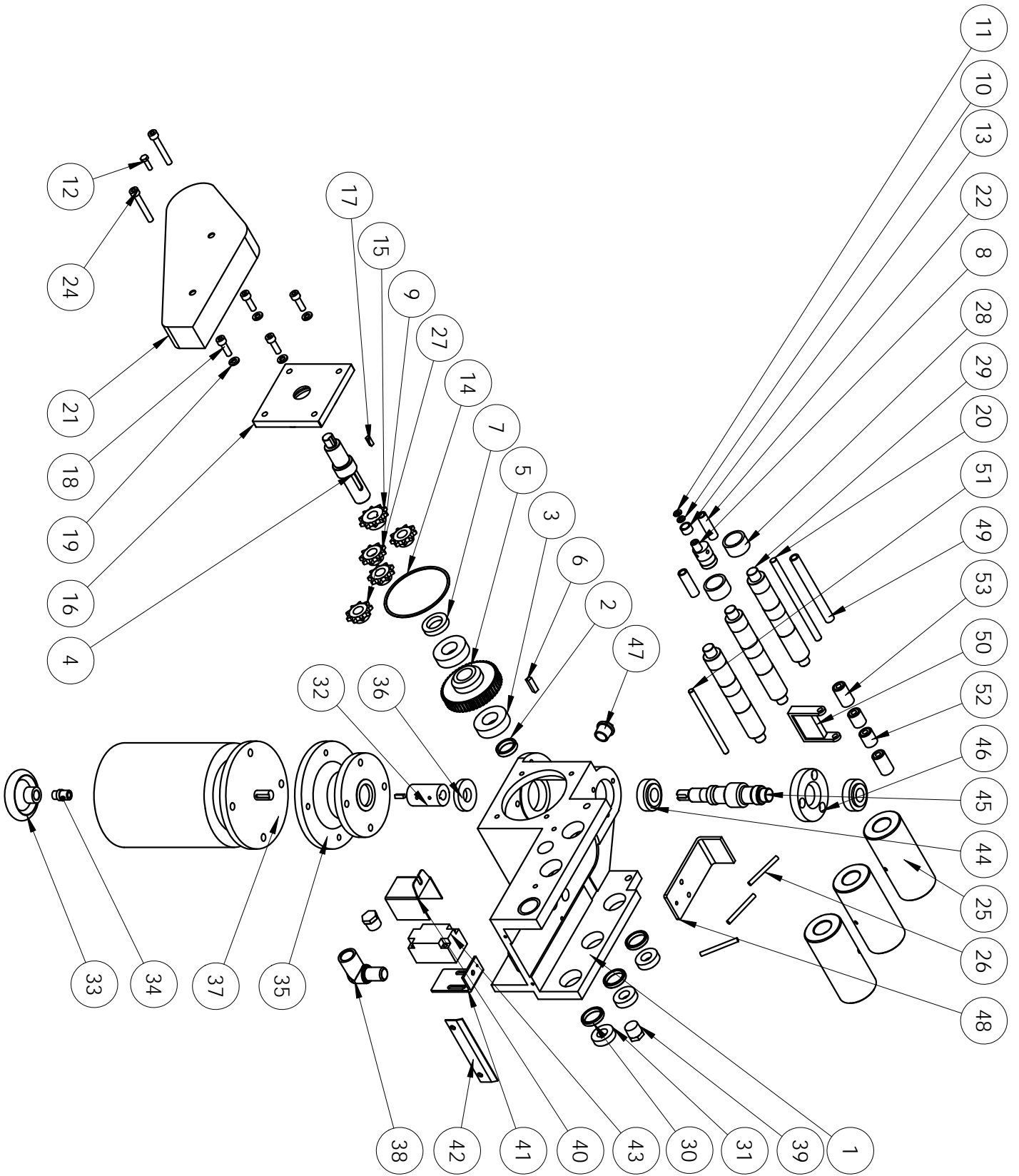

S250R-22000 固定虎鉗組 Fixed Vise Assembly

ITEM	PART NO.	PART NAME	PART NAME IN CHINESE	PART SPEC.	QTY
1	ACA-1014	fixed vise body	固定虎鉗本體		1
2	ACA-1074	washer	蝸輪軸墊圈		1
3	PP-14570	bearing	軸承		2
4	ACA-1041	worm gear shaft	蝸輪軸		1
5	ACA-1037	worm gear	蝸輪		1
6	PS-7-7-25	Key	方鍵	7x7x25L	1
7	PP-51030	Oil Seal	油封		1
8	ACA-1026	adjusting rod	鏈輪調整桿		1
9	ACA-1032	adjusting chain wheel	調整鏈輪		1
10	PPA-6	flat washer	平面華司(公)	∅6mm	1
11	PQA-6	spring washer	彈簧華司(公)	∅6mm	1
12	PLA-6-20	hex soc cap screw	外六角頭螺絲(公)		
13	PP-14020	bearing	軸承	HK1210	1
14	PP-59620	O-ring	O型環	G-100	1
15	ACA-1030	drive sprocket	主動鏈輪		1
16	ACA-1038	worm gear cap	蝸輪蓋		1
17	PS-5-5-15	key	方鍵	5x5x5L	2
18	PBA-8-25	hex soc cap screw	有頭內六角螺絲	M8x1.25x25	4
19	PQA-8	Spring washer	彈簧華司	M8	4
20	ACA-1018	feeding switch shaft	送料開關軸		1
21	ACA-1028	chain wheel cover	鏈輪護蓋		1
22	ACA-1029	cover washer	護蓋墊圈		2
24	PBA-8-55	hex soc cap screw	有頭內六角螺絲	M8xP1.25x55	2
25	ACA-1015	fixed vise roller	固定虎鉗滾輪		3
26	PRA-6-60	spring pin	彈簧銷		3
27	ACA-1031	driven chain wheel	從動鏈輪		3
28	PP-14070	bearing	軸承		3
29	ACA-1016	fixed vise roller	固定虎鉗滾輪軸		3
30	ACA-1027	fixed roller washer	固定滾輪墊圈		3
31	PP-14251	bearing	軸承		3
32	ACA-1034	shaft sleeve	接軸套		1
33	ACA-1035	driven handwheel	從動手輪		1
34	ACA-1036	shaft sleeve	從動手輪軸套		1
35	ACA-1033A	connecting flange	連接凸緣		1
36	PP-51040	oil Seal	油封		1
37	PP-31323	motor	馬達(固定虎鉗)		1
38	PUJ-040-040-01	ELBOW JOINT	彎接頭		1
39	PED-040	hexagon plug	外六角塞頭		2
40	ACA-1025	cover	送料電器遮蓋		1
41	ACA-1024	base plate	送料電器座板		1
42	ACA-1017	roller side cover	滾輪側護蓋		1
43	AHA-1025	front cover	前蓋		1
44	PP-14610	bearing	軸承		2
45	ACA-1039	worm	蝸桿		1
46	ACA-1040	worm cap	蝸桿蓋		1

S250R-22000 固定虎鉗組 Fixed Vise Assembly

ITEM	PART NO.	PART NAME	PART NAME IN CHINESE	PART SPEC.	QTY
47	PP-21050	small oil gauge	小油鏡		1
48	ACA-1019	feeding switch fixed plate	送料開關固定板		1
49	ACA-1019A	shaft sleeve	送料開關固定板軸套		1
50	ACA-1020	U bracket	送料開關U型架		1
51	ACA-1023	movable shaft	U型架活動軸		1
52	ACA-1021	short roller	送料開關短滾輪		2
53	ACA-1022	ling roller	送料開關長滾輪		2

S250R-32200 鋼刷組 Wire Brush Assembly

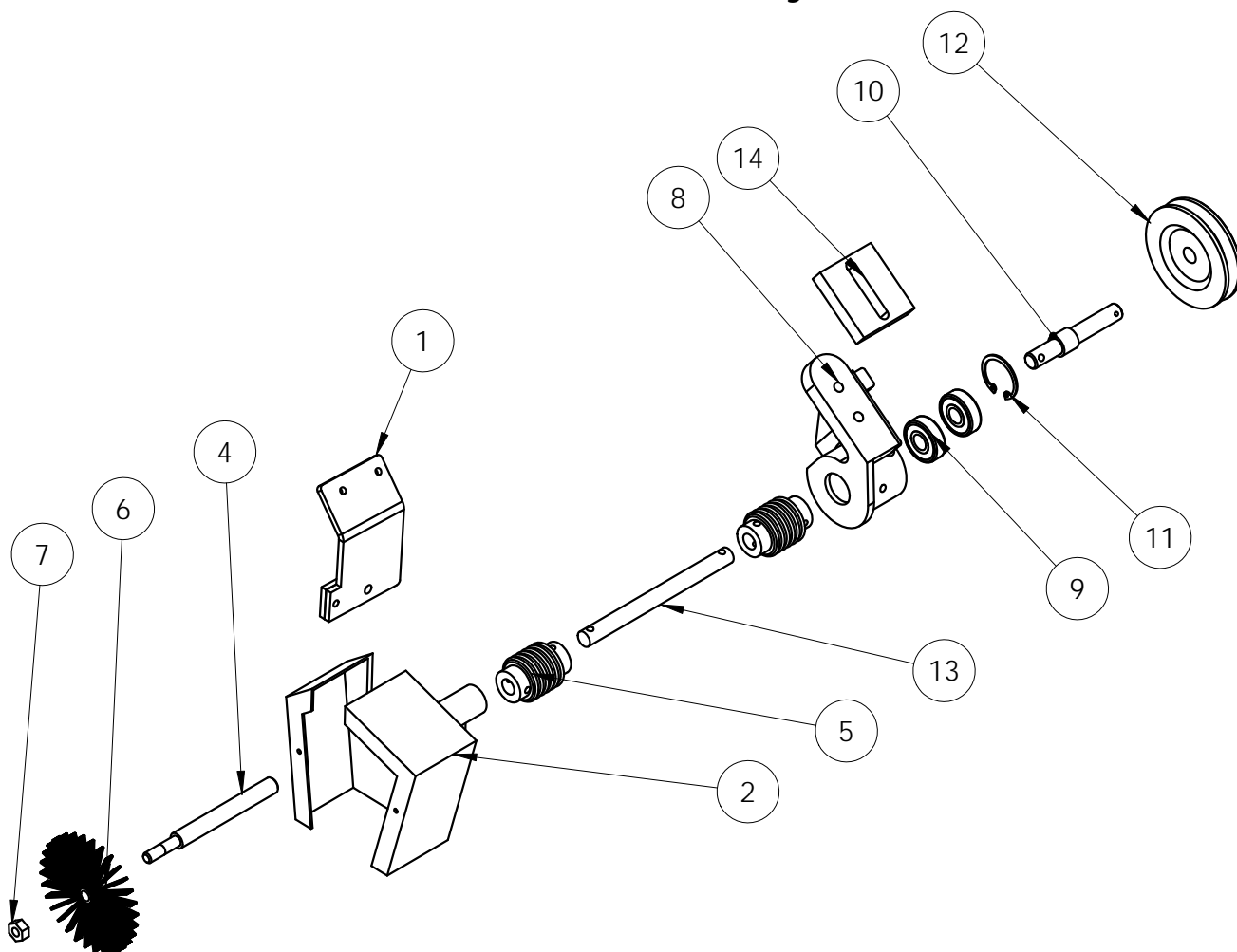

ITEM	PART NO.	PART NAME	PART NAME IN CHINESE	PART SPEC.	QTY
1	S250R-3231A	cover fixed plate	鋼刷護蓋固定板		1
2	S250R-3229	wire brush cover	鋼刷護蓋		1
3	PP-13025	DU bushing	乾式軸承		2
4	AHB-0519	wire brush shaft	鋼刷軸		1
5	PP-15010	universal joint	萬向接頭		2
6	PP-58002	wire Brush	鋼刷		1
7	POA-8	nut	螺母	M8	1
8	AHA-1211	bearing seat	軸承座		1
9	PP-14272	bearing	軸承		2
10	AHA-1207	belt wheel shaft	皮帶輪軸		1
11	PP-58109	snap ring	扣環	R32	1
12	AHA-1202	belt wheel	鋼刷皮帶輪		1
13	R1010-3223	transmission shaft	鋼刷傳動軸		1
14	R1010-3241	wire brush fixed	鋼刷固定板		1

S250R-33000 張力調整組 Tensioner Sliding Plate Assembly

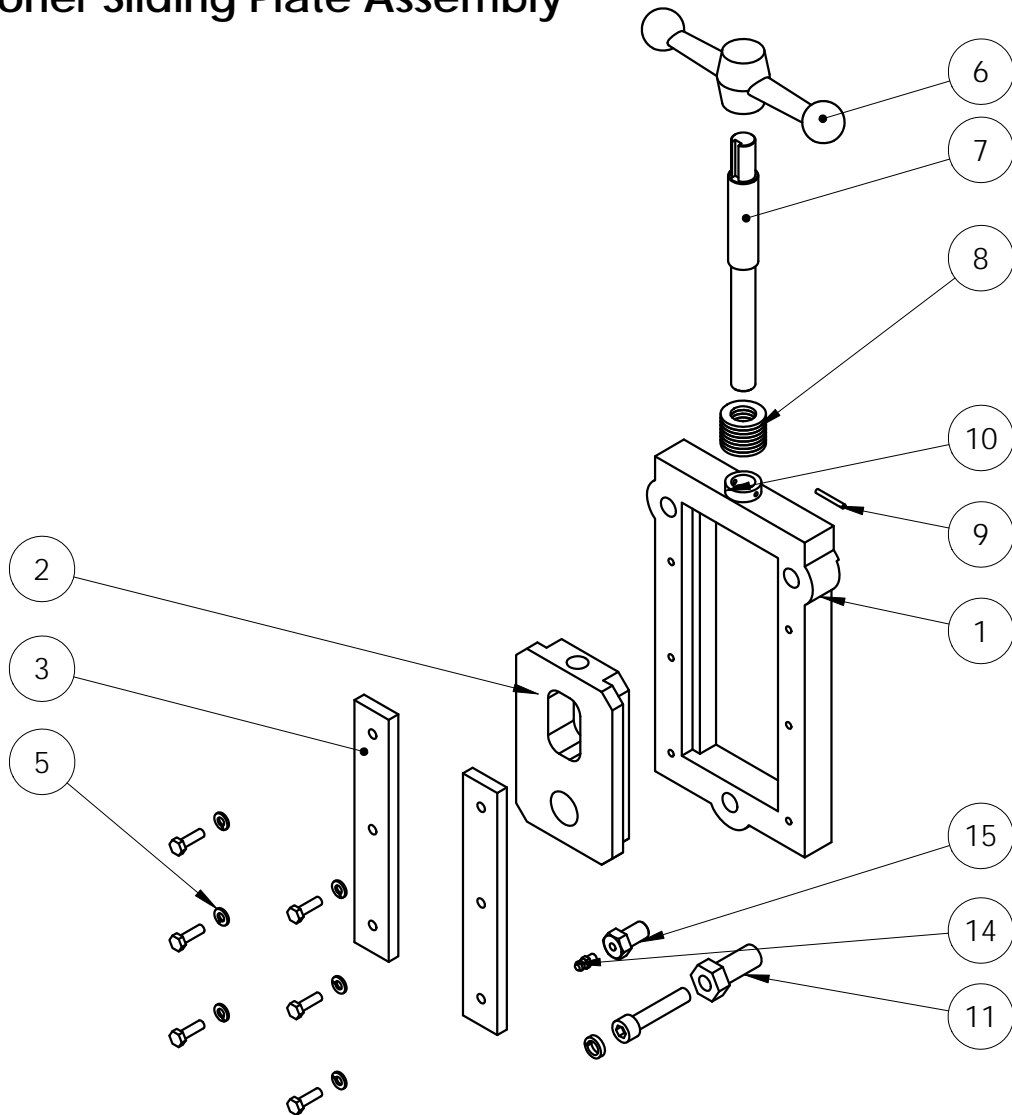

ITEM	PART NO.	PART NAME	PART NAME IN CHINESE	PART SPEC.	QTY
1	SJY-1102	blade tension bracket	張力滑板座		1
2	SJY-1102A	blade tension adjusting plate	張力調整座		1
3	MJA-2022	guide plate	壓條		2
4	pla-6-20	hex soc cap screw	外六角頭螺絲		6
5	PQA-6	spring washer	彈簧華司	彈簧華司(公)	6
6	SJY-1103	blade tension adjusting lever	張力調整把手		1
7	SJY-1115	blade tension adjusting shaft	張力調整螺桿		1
8	PPA-16	flat washer	平面華司	Ø16mm	8
9	PRA-3-25	spring pin	彈簧銷	SPP-3x25	1
10	MJA-2024	blade tension adjusting ring	張力調整固定圈		1
11	SJY-1104	blade tension screw	張力調整螺絲		1
12	pba-10-50	hex soc cap screw	有頭內六角螺絲		1
13	PQA-10	spring washer	彈簧華司		1
14	PUC-020	grease nipple	油嘴	1/4"-28UNF	1
15	SJY-1150	nipple screw	關節油嘴螺絲		1

S250R-13000 控制箱組 Control Box Assembly

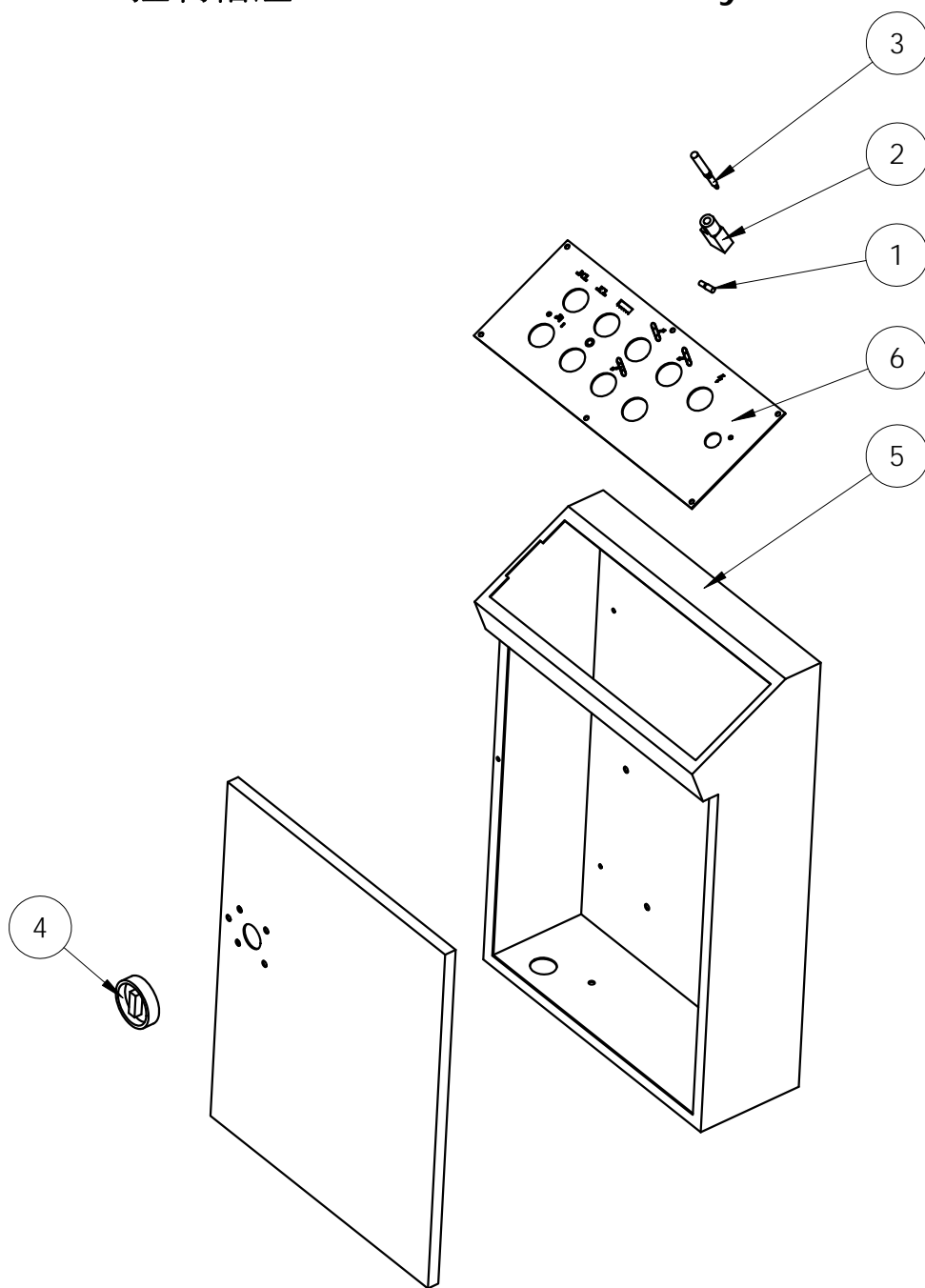

ITEM	PART NO.	PART NAME	PART NAME IN CHINESE	PART SPEC.	QTY
1	SJY-2108	needle stopper	指針檔桿		1
2	ACA-2063-1	flow control	流量控制閥整體		1
3	ACA-2063-2	flow adjusting rod	流量調整桿		1
4	PP-52123	adjusting rod	梅花調整桿		1
5	AJC-7007	Control box	控制箱		1
6	SER-2007	Control panel	控制面板		1

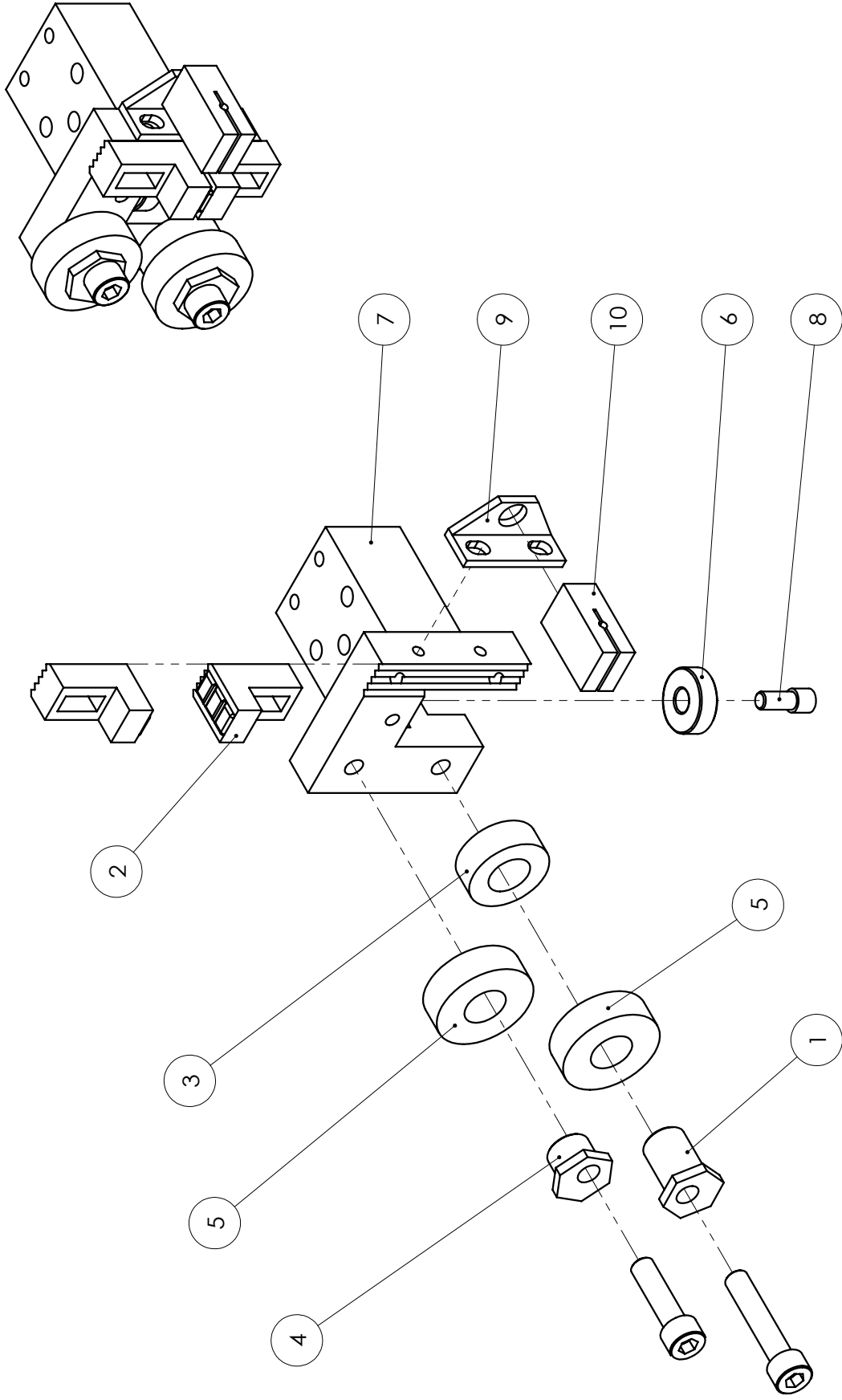

**SH-250R****SERIES PART LIST****M916J-31600 左導輪座組
LEFT GUIDE ROLLER ASSEMBLY**

M196J-31300 左導輪座組						
ITEM	PART NO.	PART NAME	PART NAME IN CHINESE	PART SPEC.	QTY	NOTE
1	MAB-6005	Eccentric bushing(long)	長偏心輪		1	
2	MAB-6006A	Carbide blade guides	鋸片固定塊		2	
3	MAB-6008	Eccentric bushing washer	偏心輪墊圈		1	
4	MAE-2041	Eccentric bushing(short)	短偏心輪		1	
5	PP-14003	Bearing	軸承	6202VV	2	
6	PP-14211	Bearing	軸承		1	
7	SJY-1110	Left guide roller seat	左導輪座		1	
8	SJY-1112A	Bearing shaft	下壓滾輪軸		1	
9	SJY-1134A	Coolant fitting seat	水龍頭固定座(大孔)		1	
10	SJY-1152	Coolant outlet port	鋸帶冷卻頭		1	

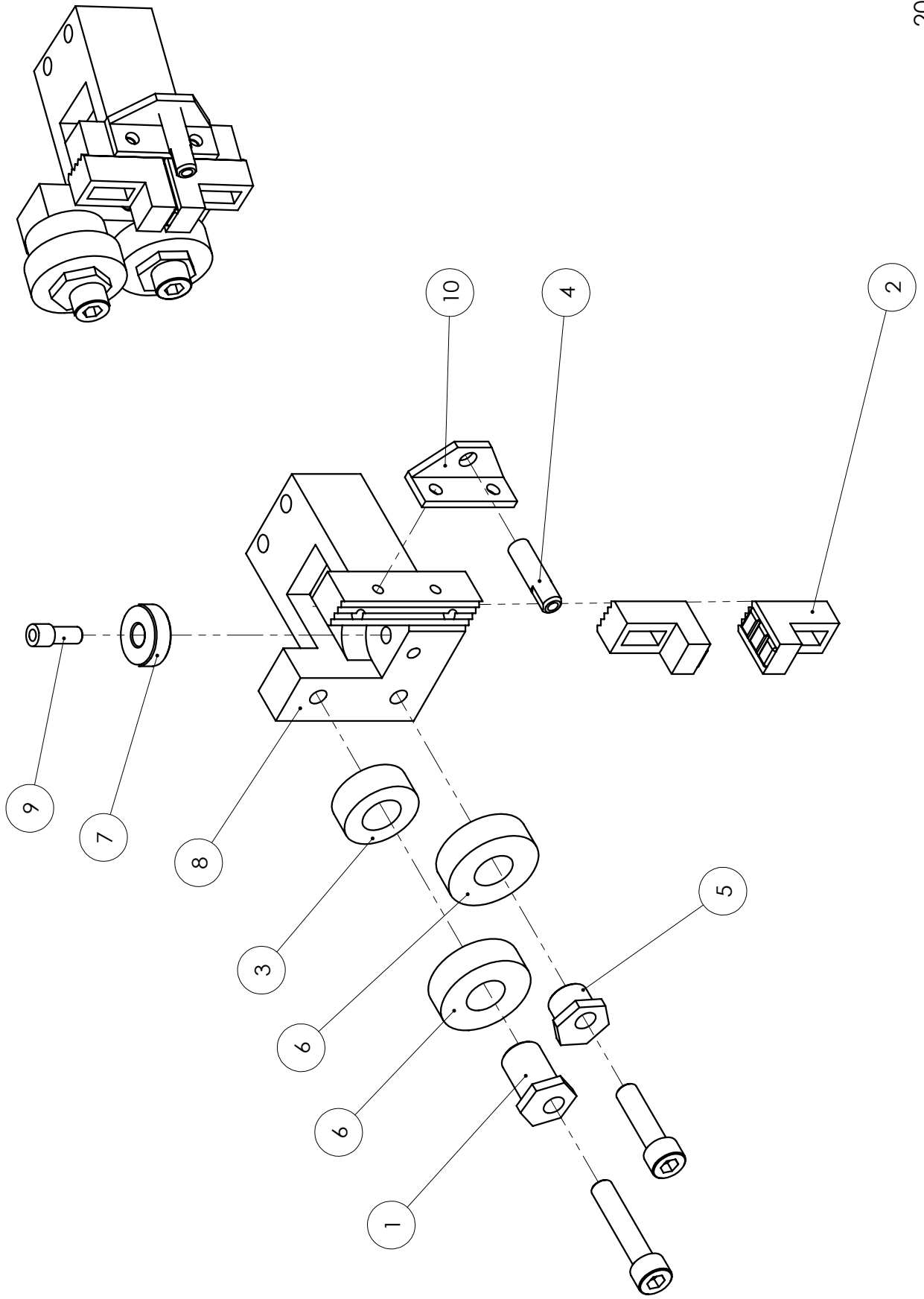

**SH-250R****SERIES PART LIST****M916J-31600 右導輪座組
RIGHT GUIDE ROLLER ASSEMBLY**

M916J-31600 右導輪座組						
ITEM	PART NO.	PART NAME	PART NAME IN CHINESE	PART SPEC.	QTY	NOTE
1	MAB-6005	Eccentric bushing(long)	長偏心輪		1	
2	MAB-6006A	Carbide blade guides	鋸片固定塊		2	
3	MAB-6008	Eccentric bushing washer	偏心輪墊圈		1	
4	MAB-6014	fixed block coolant fitting	固定塊水管接頭		1	
5	MAE-2041	Eccentric bushing(short)	短偏心輪		1	
6	PP-14003	Bearing	軸承	6202VV	2	
7	PP-14211	Bearing	軸承		1	
8	SJY-1111	Right guide roller seat	右導輪座		1	
9	SJY-1112A	Bearing shaft	下壓滾輪軸		1	
10	SJY-1134	coolant fitting seat	水龍頭固定座		1	



Vertical Plate Saws
Horizontal Billet Saws
NC/CNC Band Saws
Structural Miter-Cutting Saws
Automatic Band Saws
Industry 4.0 Cosen Predictive Computing

Visit our website at

www.cosen.com