



G320

SNC-100 Programmable Automatic
Mass Production Horizontal Bandsaw



(Non-CE Model)

Instruction Manual

The Pinnacle of Cutting Performance
Cosen Mechatronics Co., Ltd.

FROM THE MANUFACTURER

Thank you for your purchase of COSEN's bandsaw machine and your trust in the COSEN brand.

We are excited to have you as our valued customer and look forward as much as you do to the accelerated productivity, long-lasting endurance and superb cost-effectiveness this machine is about to bring to you.

To ensure you are fully utilizing our machine and being advantaged in every possible way, please do take your time and read through this instruction manual.

Any comment or suggestion in making our service better, please do not hesitate to let us know. Thank you again!

NOTE:



- Read this instruction manual carefully to familiarize yourself with the installation, operation and maintenance of your COSEN bandsaw machine.
- Operate the machine following the procedures described in the manual to prevent personal injuries or machine damage.
- Keep this manual handy and refer to it whenever you are uncertain of how to perform any of the procedures.



- For technical support or parts purchase, please contact your nearest COSEN representative or our service center:

For Europe:
email: europa@cosensaws.com
phone: +31-77-7600280
fax: +31-77-7600288
web: www.cosensaws.eu

For US, Mexico, and Canada:
email: info@cosensaws.com
phone: +1-704-943-1030
toll free: +1-877-SAWING1
fax: +1-704-943-1031
web: www.cosensaws.com

For China:
email: service@cosensaws.cn
phone: +86-152-50127815
web: www.cosensaws.cn

For Taiwan and other countries:
email: info@cosen.com
phone: +886-3-5332143
fax: +886-3-5348324
web: www.cosen.com.tw

Instruction Manual:

G320

SNC-100 Programmable Automatic Mass Production Horizontal Bandsaw
(Non-CE Model)
Ver.5 2017/10/24

© 2013 by COSEN MECHATRONICS CO., LTD.

No part of this publication may be photocopied or otherwise reproduced without the prior written permission of COSEN.

Printed in Taiwan

Safety rules



- Make sure your work area is cleared of uninvited people and obstacles every time before you start operating the machine.



- Never step or stand on the roller table. Your foot may slip or trip on the rollers and you will fall.



- Never wear gloves or loose clothing when operating the machine. It may lead to serious injury if they are caught in the running machine. Wrap or cover long hair.

- Never touch the running saw blade with gloves or not. It is dangerous if your hands, clothing or gloves are caught by the running blade.



- Make sure any use of fire is prohibited in the shop and install a fire extinguisher or other fire control device near the machine when cutting titanium, magnesium, or any other material that produces flammable chips. Never leave the machine unattended when cutting flammable materials.



- Use a water-soluble cutting fluid on this machine. Oil-based cutting fluids may emit smoke or catch fire, depending on how they are used.



- Never cut carbon or any other material that may produce and disperse explosive dust. It is possible that sparks from motors and other machine parts will ignite and explode the air-borne dust.

Safety rules



- Never adjust the wire brush or remove chips while the saw blade is still running. It is extremely dangerous if hands or clothing are caught by the running blade.
- Stop the saw blade before you clean the machine. It is dangerous if hands or clothing are caught by the running blade.
- Never start the saw blade unless the workpiece has been clamped firmly. If the workpiece is not securely clamped, it will be forced out of the vise during cutting.



- Take preventive measures when cutting thin or short pieces from the work to keep them from falling. It is dangerous if the cut pieces fall.
- Use roller tables at the front and rear sides of the machine when cutting long work. It is dangerous if the work piece falls off the machine.



- Turn off the shop circuit breaker switch before performing maintenance on the machine. Post a sign indicating the machine is under maintenance.

Table of Contents

Section 1 – Safety Information	1-1
Safety Instructions	1-1
Safeguard Devices	1-3
Emergency Stop	1-4
<i>Illustration: Emergency Stop</i>	1-5
Safety Labels	1-6
<i>Illustration: Safety Labels</i>	1-9
Hearing Protection	1-10
CE Compliance	1-10
Risk Assessment	1-10
Section 2 – General Information	2-1
Specification	2-2
Machine Parts Identification	2-3
Floor Plan	2-4
Section 3 – Moving & Installation	3-1
Location & Environment	3-1
Unpacking & Inspecting	3-2
Lifting	3-3
<i>Illustration: Lifting Points</i>	3-5
Removing Shipping Bracket	3-6
Cleaning	3-6
Installing	3-6
Supplying Hydraulic Oil	3-6
Supplying Coolant	3-7
Connecting Electric Power	3-7
Leveling & Anchoring	3-8
Installing Roller Table (Optional)	3-9
Installing Fire Control Device.....	3-9
Relocating	3-9
Section 4 – Operating Instructions	4-1
Safety Precautions	4-2
Before Operating	4-3
Control Panel	4-4
Control Panel	4-4
Control Buttons	4-5

Table of Contents

Blade Descend Pressure & Speed	4-7
HMI Touch Screen & Functions	4-7
HMI Error Codes	4-20
Standard Accessories	4-21
Optional Accessories	4-24
Unrolling & Installing the Blade	4-26
Adjusting Wire Brush	4-28
Adjusting Saw Arm.....	4-28
Adjusting Blade Speed	4-29
Breaking-In the Blade	4-29
Placing Workpiece onto Workbed	4-29
Positioning Workpiece for Cutting	4-30
Without Using Automatic First Cut Function.....	4-30
Using Automatic First Cut Function.....	4-31
Adjusting Coolant Flow	4-32
Test -Running the Machine	4-33
Cutting Operation	4-34
Using Top Clamp for Bundle Cutting.....	4-35
Terminating a Cutting Operation	4-36
Section 5 – Electrical System	5-1
Electrical Circuit Diagrams	5-1
Section 6 – Hydraulic System	6-1
Hydraulic Diagrams	6-1
Section 7 – Bandsaw Cutting: A Practical Guide	7-1
Introduction	7-1
Saw Blade Selection	7-2
VISE LOADING	7-3
BladeBreak -In	7-3
Section 8 – Maintenance & Service	8-1
Introduction	8-1
Basic Maintenance	8-1
Maintenance Schedule	8-1
Before Beginning a Day’s Work	8-2
After Ending a Day’s Work	8-2
Every 2 weeks	8-2
First 600hrs for new machine,then every 1200h.....	8-2

Table of Contents

Every Six Months	8-3
Storage Conditions	8-3
Terminating the Use of Machine	8-3
Oil Recommendation for Maintenance	8-4
Section 9 – Troubleshooting	9-1
Introduction	9-1
Precautions	9-2
General Troubles & Solutions	9-2
Minor Troubles & Solutions	9-3
Motor Troubles & Solutions	9-3
Blade Troubles & Solutions	9-4
Sawing Problems & Solutions	9-5
Re-Adjusting the Roller Table	9-12
Section 10 – Parts	10-1
Spare Parts Recommendations	10-1
Part List	10-2
Section 11 – Warranty	11-1
Warranty	11-1

SAFETY INFORMATION

SAFETY INSTRUCTIONS

SAFEGUARD DEVICES

EMERGENCY STOP

SAFETY LABELS

HEARING PROTECTION

CE COMPLIANCE

RISK ASSESSMENT

Safety is a combination of a well-designed machine, operator's knowledge about the machine and alertness at all times. COSEN's band machine has incorporated many safety measures during the design process and used protective devices to prevent personal injuries and potential risks. Warning labels also serve as a reminder to the operator.

Throughout this manual, you will also see various safety-related symbols indicating important information that you should take note of prior to use of the machine or part of its functions. These important safety instructions do not cover all possible situations that might occur. It is your responsibility to take caution and follow procedures stated in this manual when installing, maintaining and operating your machine. Cosen will not be liable for damages resulting from improper use.

SAFETY INSTRUCTIONS

What the icons and signs in this user manual mean:



This icon marks **DANGER**; hazards or unsafe practices that may result in **severe personal injury or death**.



This icon marks **WARNING**; hazards or unsafe practices that may result in **personal injury or damage to the machine**.



This icon marks **CAUTION**; information that should be read before use to prevent **damage to the machine**.



Supplementary information to the procedures described in this manual.



Call your local agent or our service center for help.



This manual has important safety information. Read through it carefully before operating this machine to prevent personal injury or machine damage. Learn the operation, limitation and the specific potential hazards peculiar to this band saw.



Do not operate this machine unless it is completely assembled.



Make sure the power switch is off before plugging in power cord.



Disconnect the power cord before making adjustment, maintenance or blade changes.



Keep all guards and shields in place before installing or starting up the machine.



Wear proper apparel during operation and when servicing the machine.



Keep unauthorized personnel away.



Do not reach over or stand on any part of the machine.



Never hold the material by hand for cutting. Always use the vise and make sure the material is clamped securely before cutting.



It is dangerous to operate the machine when the floor is slippery. Keep the floor clean and dry. Check for ice, moisture, or grease before entering.



Do not use the machine to cut explosive material or high pressure vessels as it will generate great amount of heat during the sawing process and may ignite an explosion.



Keep the work environment safe. Do not use band saw in a damp or wet location.



Never operate while under the influence of drugs, alcohol or medication.



All users must read it before performing any activity on the machine, such as replacing the saw band or doing regular maintenance.



Some personal protective equipment is required for the safe use of the machine, e.g. protection goggles.



Keep blade protection cover and wheel covers in place and in working order.



Use recommended accessories. Improper accessories may be hazardous.



Keep your work area well illuminated at minimum 500 lumen.



Keep your work area clean. Cluttered and slippery floors invite accidents.



Remove adjusting keys, wrenches or any loose parts or items from the machine before turning on power.



Check for damaged parts. Before continuing using the machine, the damaged part should be checked and replaced.



Moving parts should be kept in proper alignment and connection with the machine. Check for breakage, mounting and any other conditions that may affect its operation. Any damaged part or guard should be properly repaired or replaced.



When a workpiece is too long or heavy, make sure it is supported with a roller table (recommended).



Always remember to switch off the machine when the work is completed.



Use a sharp saw blade and keep the machine in its best and safest performance by following a periodical maintenance schedule.



Do not force the band saw beyond its intended use. It is safer to operate with the cutting rate for which it was designed.

SAFEGUARD DEVICES

The safeguard devices incorporated in this machine include the following two main parts:

1. Protection covers & guards
2. Safety-related switches

Protection Covers & Guards

1. Idle wheel housing cover
2. Drive wheel housing cover
3. Gear reducer cover
4. Wire brush belt cover
5. Blade guard cover (left & right)



The protection devices should always be mounted on the machine whenever the machine is running.



Do not remove any of these safeguard devices under any circumstances except when servicing the machine. Even skilled service technicians should still take cautions when performing repairs or service on the machine with any of these protectors removed. It is the responsibility of the user to make sure all these elements are not lost and damaged.



Take note of the following main moving parts on the machine prior to and during machine operation:

- Saw bow assembly
- Drive and idle wheels
- Blade guide arm
- Saw blade guide rollers
- Quick approach device
- Wire brush
- Chip conveyor (optional)
- Workpiece clamping vises
- Shuttle vises and workbed rollers
- Top clamps (optional)
- Gear reducer

Illustration: Safety Fence

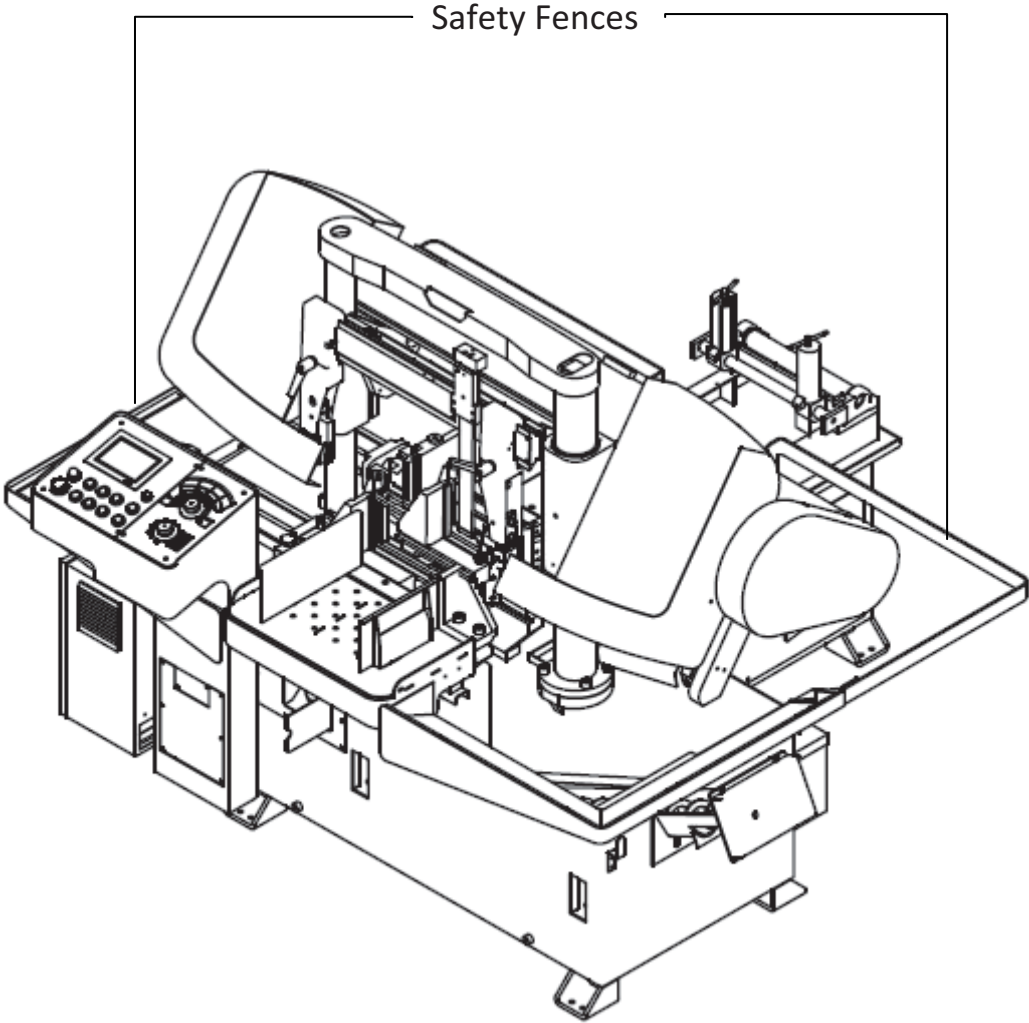

Safety Related Switches

To protect the operator, the following safety related switches on the machine are actuated when the machine is in operation.

Wheel motion detector	This is a proximity sensor used to detect the motion of the drive wheel. Once the saw blade is broken or as soon as it starts slipping, the sensor will detect and stop the drive wheel and the machine.
Power switch	Located on the cover of electrical cabinet, the power switch controls the main power of the machine. Up to your company's internal rules, this power switch can be locked with a padlock or a luggage lock to protect the operator and the machine.
Emergency stop button	Located on the control panel, the button when pressed will stop the machine completely.
Vise clamp switch	This switch assures firm clamping of the workpiece. If the workpiece is not clamped properly, the saw blade is not allowed to run.
Wheel cover interlock switches (CE model only)	Located on the two wheel housings, these switches are used to assure that the machine will stop whenever the wheel covers are open. This device is to protect users from being cut by the running saw blades.

Among all these safety switches, some of them are used to protect the users and some of them are used to prevent damage to saw blades, the workpiece and the machine itself, etc. We have taken every precaution to prevent injury or damage and to provide safe and economical operation of the machine.

EMERGENCY STOP

Designed to be easily accessible, the emergency stop button is located on the left bottom corner on the control panel and is made in red color and rubber material. For CE models, supplementary emergency stop button may be available at other area(s) of the machine depending on machine type. Please refer to *Illustration: Emergency Stop*.

When you press the button, the machine will immediately come to a full stop to avoid injury or damage when an accident occurs. The button will be locked when you press it. To unlock it, pull it upward.

You should press it immediately without any hesitation when observing:

- An emergency situation that would cause any injury or damage
- An abnormal situation or problem such as fire, smoke, abnormal noise and etc.

Illustration: Emergency Stop

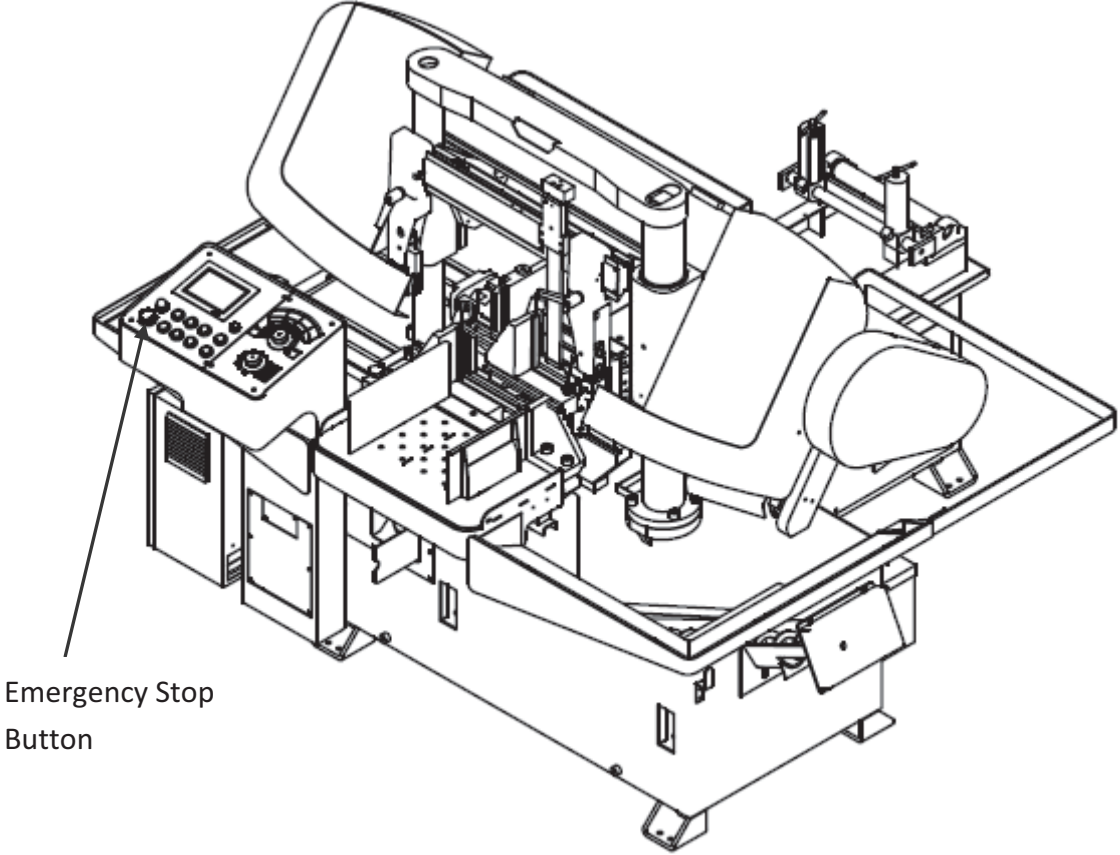

Emergency Stop
Button

SAFETY LABELS

Please read through and understand the safety labels before operating the machine. Refer to *Illustration: Safety Labels*.









Label	Meaning	Label	Meaning
	<p>Hazardous Voltage</p> <p>TURN POWER OFF before servicing. Failure to following the warning can result in severe injury.</p>		<p>DANGER: Running Blade</p> <p>Blade runs through this area. Keep your hands away from a running blade to avoid severe injury. The arrow indicates direction of the blade.</p>
	<p>Cutting Hazard</p> <p>KEEP COVER CLOSED while the blade is running. Turn power off before opening cover. Failure to follow the warning can result in severe injury.</p>		<p>Cutting Hazard</p> <p>KEEP HAND OFF while the blade is running. Turn power off before opening cover. Failure to follow the warning can result in severe injury.</p>
	<p>Please add antifreeze coolant when the ambient temperature is below 0°C (32°F).</p>		<p>Loose Hand Hazard</p> <p>KEEP HAND OFF. Do not touch chip conveyor. Failure to follow the warning can result in severe injury.</p>
	<p>Impact Hazard</p> <p>WEAR SAFET SHOES. Do not approach dropping area during operation.</p>		<p>Replace the hydraulic oil every six months or every 1,200 hours of operation.</p> <p>Oil specification: Shell TELLUS 27 or Mobil DTE OIL LIGHT / HYDRAULIC 28</p>
	<p>Cutting Hazard</p> <p>KEEP COVER CLOSED while the blade is running. Turn power off before opening cover. Failure to follow the warning can result in severe injury.</p>		<p>Cutting Hazard</p> <p>KEEP HAND OFF while the blade is running. Turn power off before opening cover. Failure to follow the warning can result in severe injury.</p>

Illustration: Safety Labels

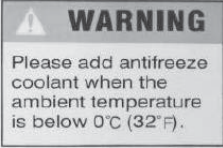

HEARING PROTECTION

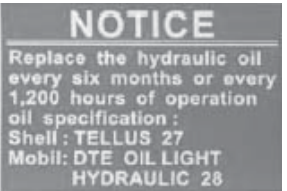

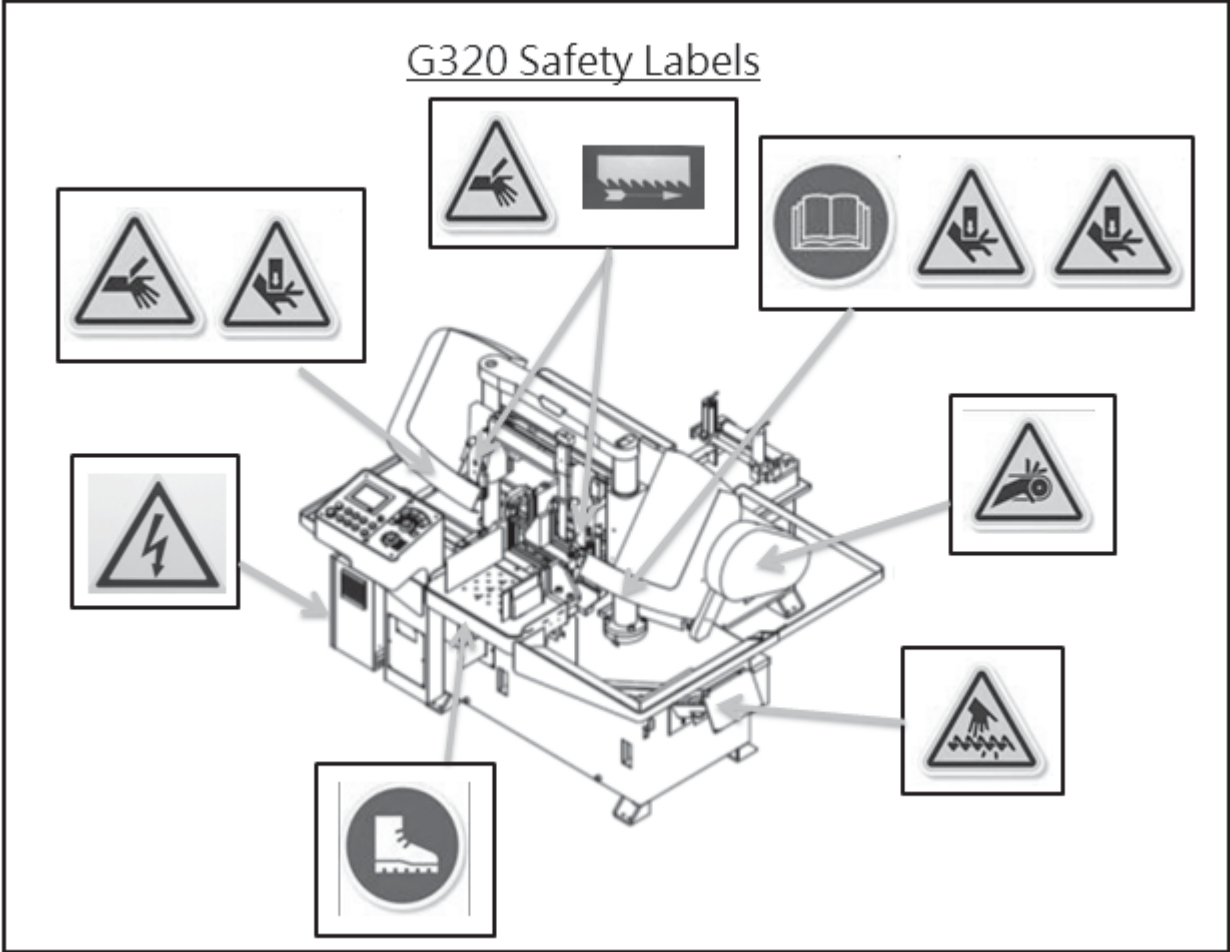
Always use ear protection!

When your machine is running, noise generated by the machine may come from the following:

- Saw blade during cutting or material feed mechanism
- Wire brush unit
- Chip conveyor unit
- Speed reducer
- Hydraulic motor/pump
- Belt transmissions variable speed motors
- Blade motor
- Coolant pump
- Drive wheel
- Parts not assembled tightly causing mechanical vibration

Our products pass noise testing less than 78 dBA. Noise level vary according to working conditions and we recommend ear plugs or other hearing protection at all time. If your machine produces an undesirable noise while it is running, you should:

1. Make sure all maintenance tasks have been performed following the prescribed maintenance schedule (Refer to Section 8).
2. If maintenance does not seem to solve the problem, follow the troubleshooting procedures under Section 9.

CE COMPLIANCE

Cosen's CE model is designed to satisfy regulations of the Council Directive on the approximation of the laws of the Member States relating to machinery (2006/42/EC) - Annex I Essential health and safety requirements relating to the design and construction of machinery.

RISK ASSESSMENT

Risk assessment generally takes account of intended use and foreseeable misuse, including process control and maintenance requirements. We made every effort to avoid any personal injury or equipment damage during the machine design stage. However, the operator (or other people) still needs to take precautions when handling any part of the machine that is unfamiliar and anywhere on the machine that has potential hazards (e.g. the electrical control box).

GENERAL INFORMATION

SPECIFICATION

MACHINE PARTS IDENTIFICATION

FLOOR PLAN

This band saw machine is designed by Cosen's R&D engineers to provide you the following features and advantages:

Safety

- This machine is designed to fully protect the operator from its moving parts during cutting operation.
- The machine and each component has passed strict testing (Council Directive on the approximation of the laws of the Member States relating to Machinery).
- The machine will shut off automatically when the saw blade is broken, protecting both the operator and the machine.

Convenience & High-Performance

- The machine is designed in the way that the operation and adjustment can be easily performed.
- The machine will stop automatically when out of stock.
- Dual valve system is designed to achieve optimal cutting performance with the simple setting of feed rate and perspective cutting pressure for different material.

Durability

- The intended life-span of the machine is counted based on regular daily operation. It is calculated with the life expectancy of 10 years under normal operating condition and exact attention to the maintenance schedule.

8 hours × 5 days × 52 weeks × 10 years = 20,800 hours

SPECIFICATION

Model	G320 SNC-100 Programmable Automatic Mass Production Horizontal Bandsaw	
Capacity	Round	325 mm (12.8 in)
	Square	325 mm (12.8 in)
	Rectangular (H x W)	325 x 380 mm (12.8 x 15.0 in)
	Bundle Cutting	W: 190 ~ 300 mm (7.5 ~ 11.8 in) H: 70 ~ 140 mm (2.7 ~ 5.5 in)
Saw Blade	Speed	20~100 m/min (66~328 ft/min)
	Size	4,240 x 34 x 1.1 mm (166.9 x 1.3 x 0.042 in)
	Tension	Hydraulic with automatic blade breakage detection
	Guide	Interchangeable tungsten carbide
	Cleaning	Steel wire brush with flexible drive shaft driven by main motor
Motor Output	Saw Blade	5 HP (3.75 kW)
	Hydraulic	1 HP (0.75 kW)
	Coolant Pump	1/8 HP (0.1 kW)
Tank Capacity	Hydraulic	35 L (9.2 gal)
	Coolant	75 L (19.8 gal)
Vise	Control Method	Hydraulic with full stroke cylinder
	Clamping Pressure	23 kg/cm ²
Feeding Length	Mode	Hydraulic, NC Automatic
	Single Stroke	403 mm (15.9 in)
	Multi Stroke	Max. 99 meter (999 in)
	Rest Piece	50 mm (2 in)
Workbed Height	800 mm (31 in)	
Weight	Net	2,000 kg (4400 lb)
	Gross	2,200 kg (4840 lb)
Floor Space (W x D x H)	2,400 x 2,165 x 1,640 mm (94.5 x 85.2 x 64.6 in)	
Operating Environment	Temperature	5~40°C (41~104°F)
	Humidity	30%~85% (without condensation)

MACHINE PARTS IDENTIFICATION

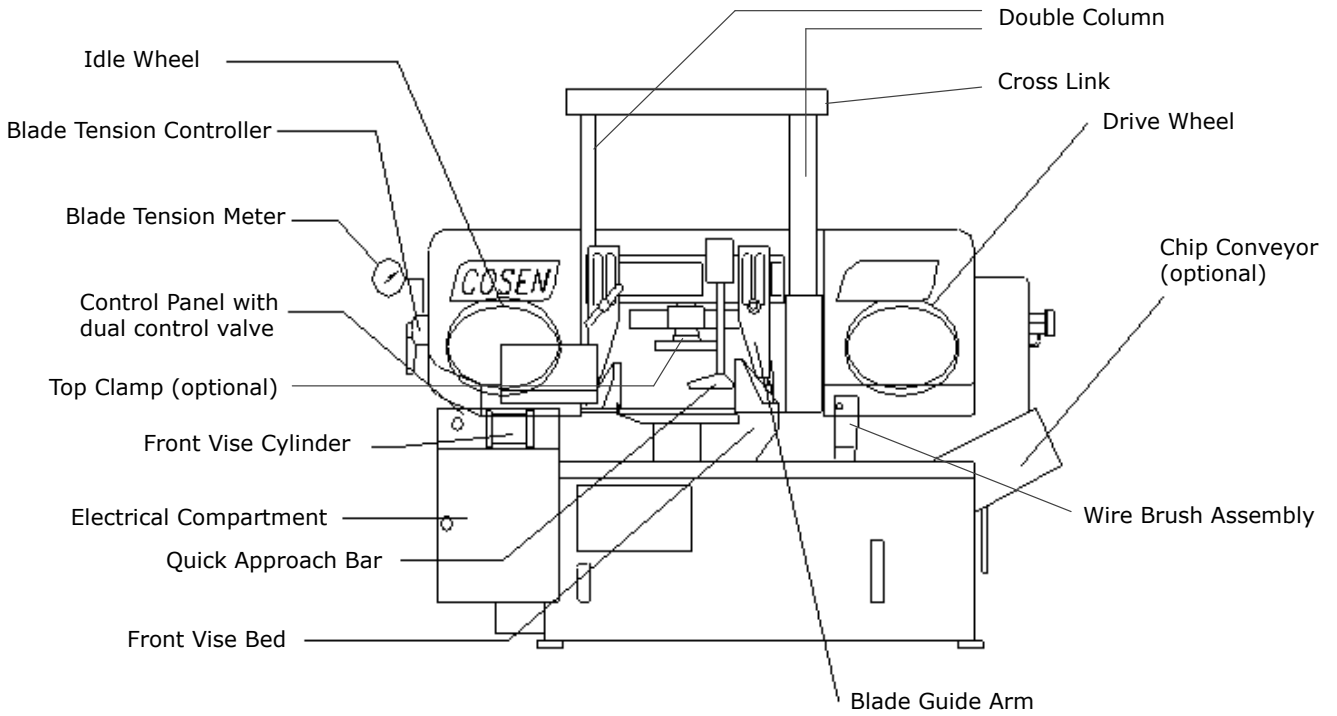

Machine front view

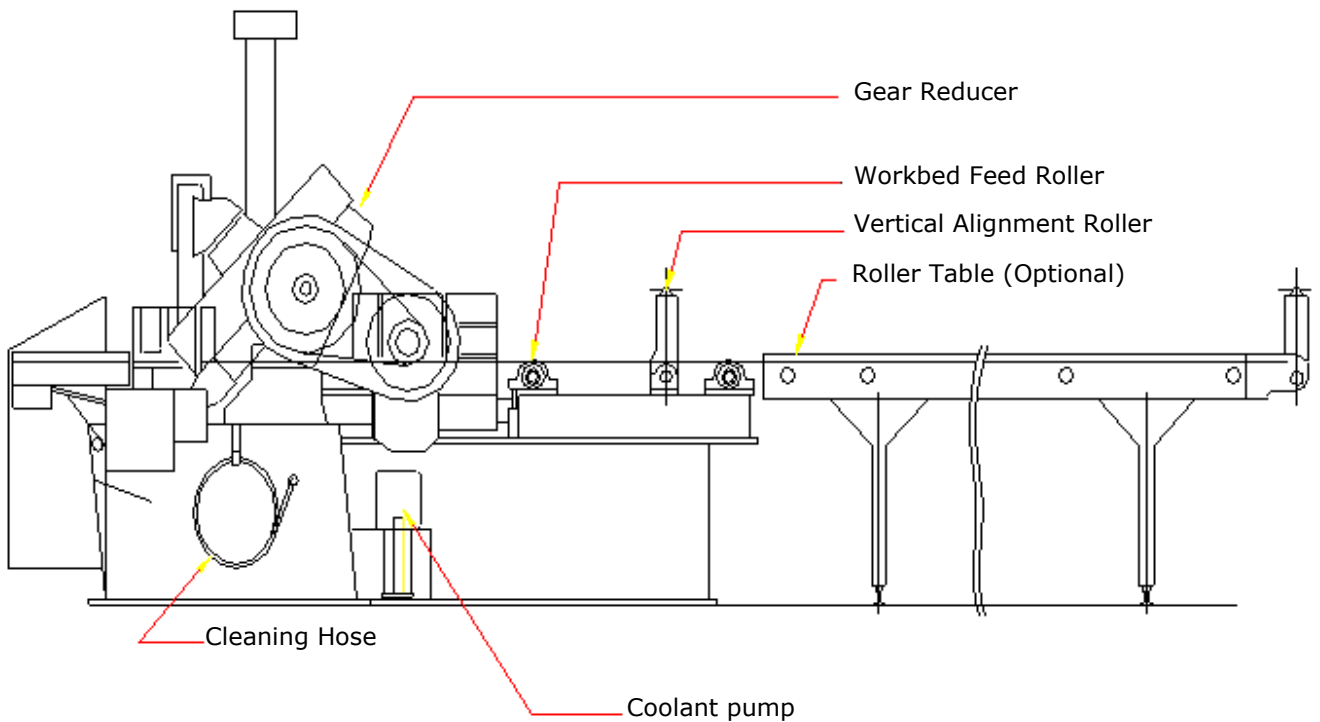

Machine side view

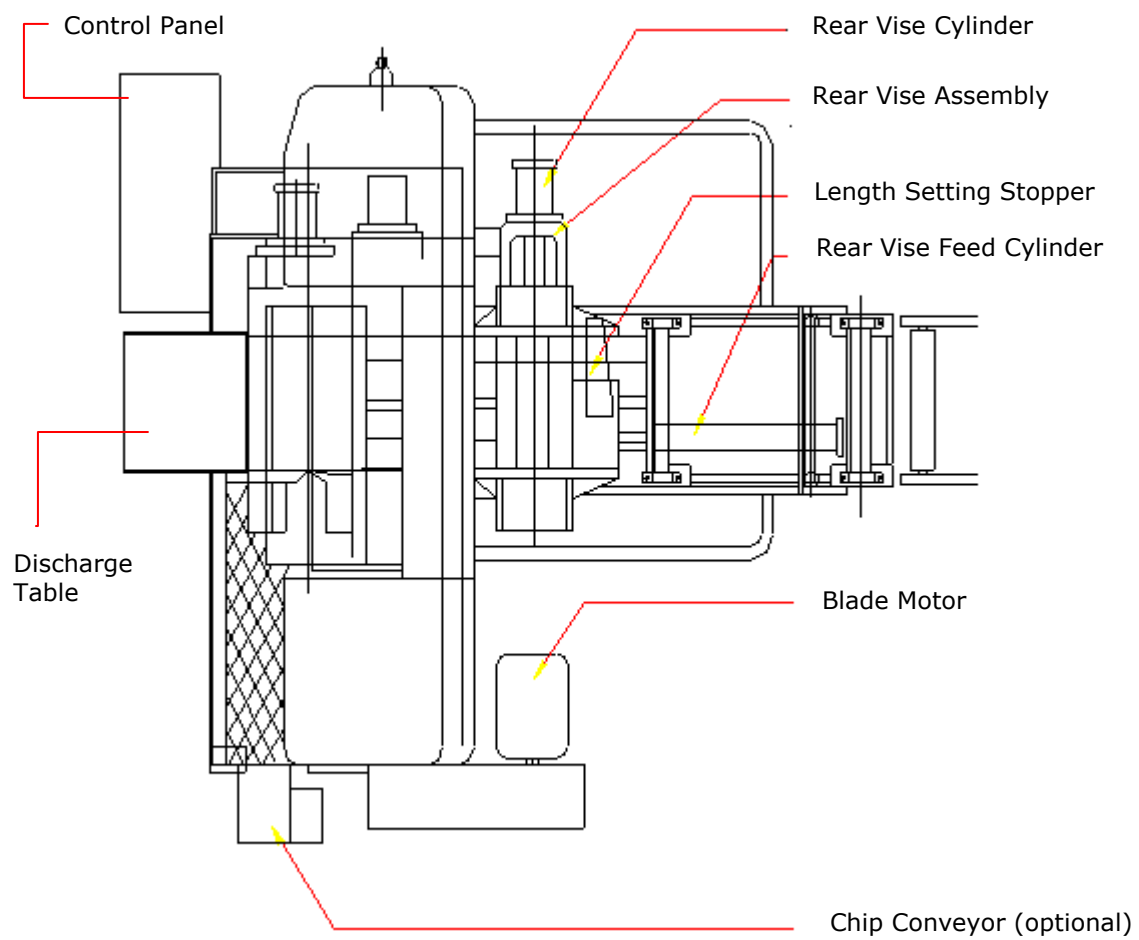

Machine top view

FLOOR PLAN

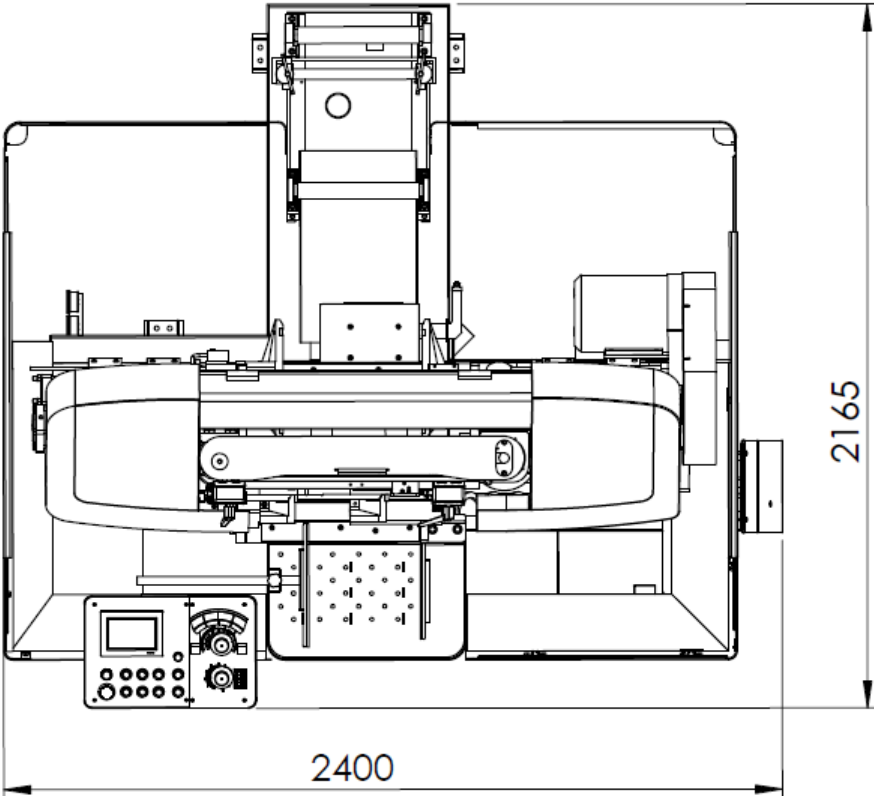

Machine top view

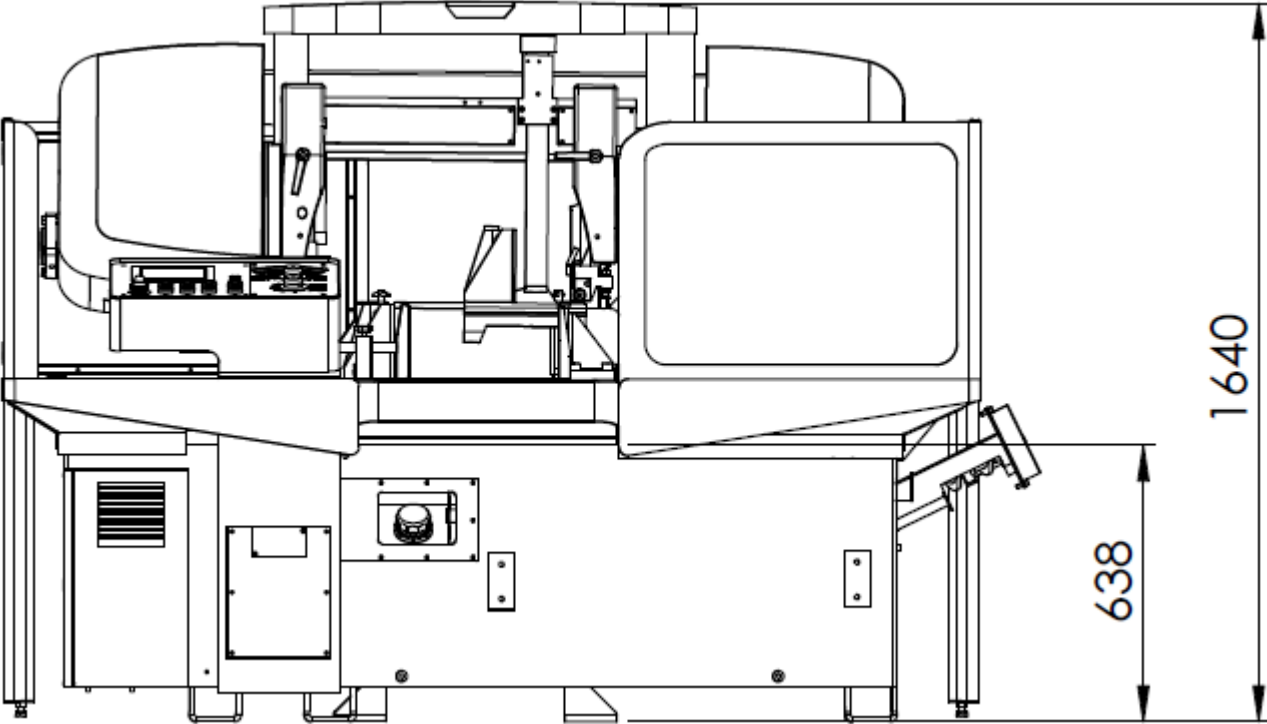

Machine front view

MOVING & INSTALLATION

LOCATION & ENVIRONMENT

UNPACKING & INSPECTING

LIFTING

REMOVING SHIPPING BRACKET

CLEANING

INSTALLING

RELOCATING

LOCATION & ENVIRONMENT

For your safety, please read all information regarding installation before proceeding. Install your machine in a place satisfying all of the following conditions:

Space:

- Leave enough free space around the machine for loading work and unloading cut-off pieces as well as for maintenance and inspection. Refer to *Section 2 General Information - Specification* for machine dimensions and floor space.

Environment:

- Well lighted (500 lumen at minimum).
- Floor kept dry at all times in order to prevent operators from slipping.
- Away from direct exposure to the sunlight
- Room temperature between 5°C to 40°C.
- Humidity level kept at 30%~95%“(without condensation) to avoid dew on electric installation and machine.
- Away from vibration of other machines
- Away from powders or dusts emitted from other machines
- Avoid uneven ground. Choose a solid level concrete floor which can sustain weight of both machine and material weight.
- Limit the operation area of the machine to staff only.



UNPACKING & INSPECTING

- Unpack your machine carefully to avoid damage to machine parts or surfaces.
- Upon arrival of your new band saw, please confirm that your machine is the correct model and it comes in the same specification you ordered by checking the model plate on the machine base.
- It is also imperative that a thorough inspection be undertaken to check for any damage that could have occurred during shipping. Pay special attention to machine surface, equipments furnished and the electrical and hydraulic systems for damaged cords, hoses and fluid leaks.
- In the event of damage caused during shipping, please contact your dealer and consult about filing a damage claim with the carrier.
- Your machine comes in with a set of tools for you to maintain the machine. The accessories furnished are as follows:
 1. Tool box 1 pc
 2. Grease gun 1 pc
 3. Screwdriver (+, -) 2 pcs
 4. Open-ended spanner 3 pcs
 5. Hexagon wrench 1 set
 6. Chip spade (only for manual models) 1 pc
 7. Operation manual 1 pc



Should you find any missing accessories, please contact your local agent immediately.

LIFTING

When moving the machine, we strongly suggest you choose any one of the methods described below to move your machine.



1. **Use a crane (Only applies to the machine with the design of the hanging point.)**

Move the machine to its location by using a crane and a wire rope sling that can fully withstand the weight of the machine (refer to machine specification under Section 2 *General Information*).



Machine hanging with a crane should be done strictly according to the hanging points designated by the original manufacturer. If there is any doubt on missing hanging points on your machine, please consult with the original manufacturer or its qualified agent before hanging the machine.

- Machine lifting is likely to damage the machine if not performed properly.



You must have a qualified crane operator to perform the job.

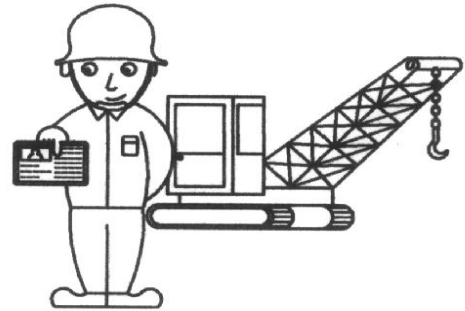

- You must use tools and equipment with the proper tensile strength and use proper method when moving your machine.

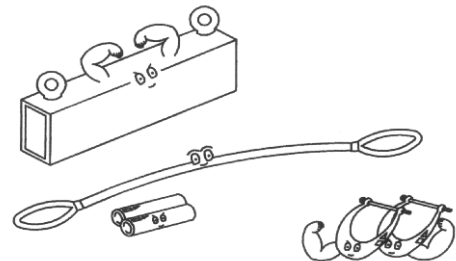

- Apply the wire rope sling to the lifting hooks on the four ends of the machine. Refer to *Illustration: Lifting Points for exact locations*.

- Slowly lift the machine. Be sure to protect the machine from impact or shock during this procedure. Also watch out your own fingers and feet to avoid injuries.

- Keep the machine well balanced during lifting process and make sure the wire rope does not interfere with the saw frame.

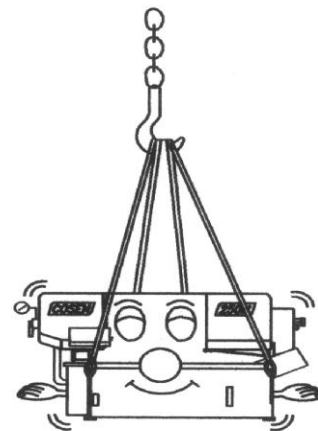

- When you work together with more than two people, it is best to keep constant verbal communication with each other.

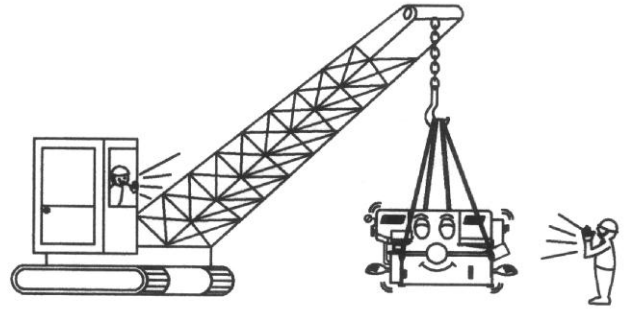

2. **Use a forklift (Only applies to the machine with the design of the lifting point.)**

Make sure that the lifting rod can fully withstand the weight of the machine. (Refer to *Section 2 – General Information for Specifications.*)



Machine lifting with a forklift should be done strictly according to the lifting points designated by the original manufacturer. If there is any doubt on missing lifting points on your machine, please consult with the original manufacturer or its qualified agent before lifting the machine.

- Machine lifting is likely to damage the machine if not performed properly.



You must have a qualified forklift operator to perform the job.



- You must apply proper forklift technique to avoid damage to the machine.



Make sure the forks are able to reach in at least 2/3 of the machine depth.

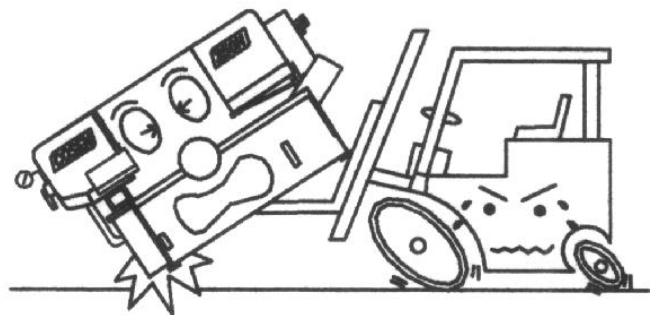

- You must keep the machine balanced at all times.



Make sure the forks are centered before use.

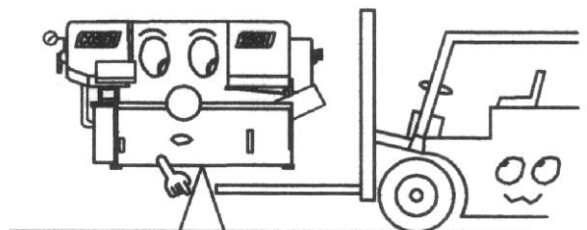

(Illustration only.)

3. Use rolling cylinders

You can use rolling cylinders to move your machine in a small machine shop environment.

- You must use rolling cylinders made in material of proper compressive strength.

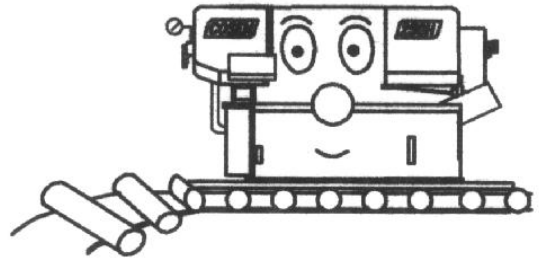

4. Other ways to move



If the machine does not have  or  stickers, please contact your local agent immediately.

Illustration: Lifting Points

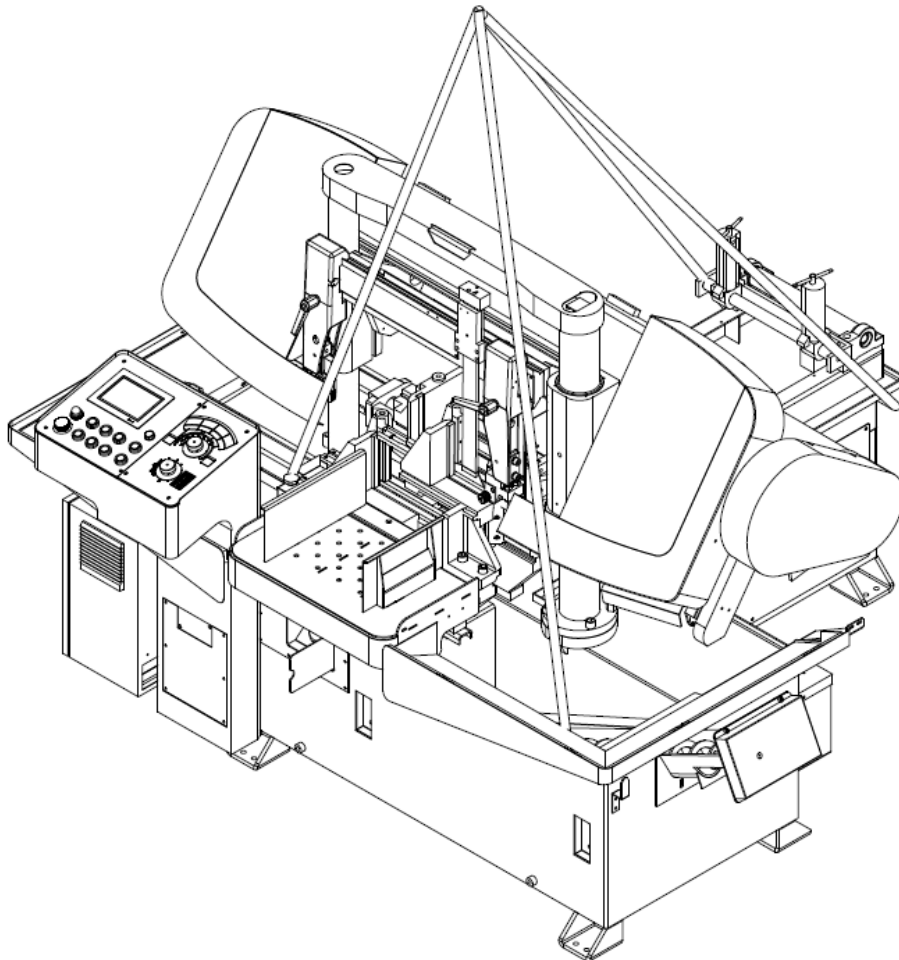

Minimum weight capacity for each wire rope: **2.5 ton**

Total number of wire ropes required: **4**

REMOVING SHIPPING BRACKET

- After the machine has been properly positioned, remove the shipping bracket that is used to lock the saw frame and the saw bed.
- Retain this bracket so that it can be used again in the event that your machine must be relocated.

CLEANING

After the machine has been placed at the designated position, remove the rust-preventive grease with wiping cloth dampened with cleaning oil or kerosene. Apply machine oil to machine surfaces that are prone to rust.



Do not remove the rust-preventive grease with a metal scraper and do not wipe the painted surfaces with solvent as doing so would damage surface paint.

INSTALLING

Cosen's bandsaw machine is relatively easy to install. Follow these six easy steps to install your machine.

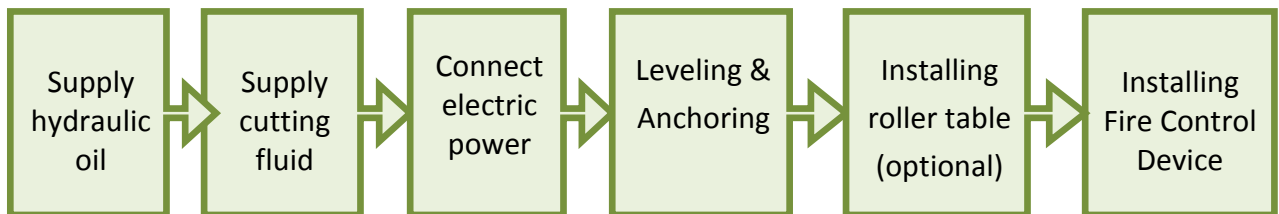

Supplying hydraulic oil

Open the filler cap and fill the hydraulic oil tank to above 2/3 or full level.

Check the sight gauge to make sure the oil level in the tank.



Refer to specification chart under Section 2 for tank capacity.



Oil tank should be full already if it is a new machine that operates for the first time.



Supplying coolant

Fill the coolant tank to the middle level of the sight gauge by pouring the coolant from above the chip conveyor.

Use the sight gauge to check the coolant level remaining in the tank.



Always check the coolant supply before starting the machine. If the coolant pump is started without enough coolant supply in the tank, the pump and its drive motor may be damaged.



Refer to specification chart under Section 2 *General Information* for tank capacity.



Consult your coolant supplier for bandsaw use regarding coolant type and mix ratio.

Connecting electric power



Have a qualified electrician make the electrical connections.



If the power supply voltage is different from the transformer and motor connection voltage shown on the label attached to the electrical compartment of the machine, contact COSEN or your agent immediately.



Connect to power supply independently and directly. Avoid using the same power supply with electric spark machines such as electric welder. Unstable electric tension may affect your machine's electric installation from working properly.



Ground the machine with an independent grounding conductor.



Supply voltage: 90% - 110 % of nominal supply voltage.



Source frequency: 99% - 101 % of nominal frequency.



Refer to the specification chart under Section 2 for total electric power consumption of the motors and make sure your shop circuit breaker is capable of this consumption amount. Also use a power supply cable of proper size to suit the power supply voltage.

1. Turn off the shop circuit breaker.
2. Make sure the machine circuit breaker switch on the electrical compartment door is turned to OFF.
3. Remove the screw securing the electrical compartment and then open the door.
4. Pull the power supply cable and grounding conductor through the power supply inlet into the electrical compartment. (Shown right)
5. Connect the power supply cable to the circuit breaker (N.F.B.) to the R, S and T terminals, and connect the ground cable to the E terminal.
6. Close the compartment door and fasten the screw back.
7. Turn on the shop circuit breaker and then turn the machine circuit breaker switch to ON. The *Power Indicator* on the control panel will come on.
8. Turn clockwise to unlock the *Emergency Stop* button and press the *hydraulic ON* button to start the hydraulic motor.
9. Make sure the sawing area is clear of any objects. Start the blade and check the blade rotation. If the electrical connections are made correctly, the blade should run in a counterclockwise direction. If not, shut the hydraulics off, turn off the machine as well as the shop circuit breaker. Then swap the power the power cable conductors connected to R and T terminals.
10. Repeat step 6 to 9 to ensure the electrical connections are in the right order.

Leveling

Place spirit level on the vise slide plates and the work feed table.

Level the machine in both directions i.e. along and across the machine. Adjust the level of the machine by turning the leveling bolts.



Make sure all leveling bolts evenly support the machine weight.



In some cases, leveling the machine with a slight slope toward the front of the machine is recommended as it would prevent coolant from running down cutting material especially tubes or bundles. To do so, make the rear end of the machine approximately 10 mm higher than the level of the front end.



Anchoring

Normally there is no need to anchor the machine. If the machine is likely to vibrate, fix the machine to the floor with anchor bolts.

Shock absorption steel plates are provided and can be placed under each leveling bolt to prevent their sinking into the concrete floor.

Installing roller table (optional)

The roller table is used to support long material at the rear and/or the front of the machine.

If you have ordered the optional roller table for cutting long material, position it before or behind the machine.

Level the roller table and the stand with the machine by adjusting the leveling bolts.



Installing Fire Control Device

Install a fire extinguisher or any other fire control device in the shop in case a fire breaks out.

RELOCATING

We recommend you follow these procedures when relocating or shipping your machine to other place:

1. Descend the saw frame to its lowest position then turn off the power.
2. Fix the saw frame using the shipping bracket that originally came with the machine.
3. If you are shipping the machine, pack the machine carefully with industrial plastic wraps to protect it from dust.
4. Use a crane or forklift to raise it. If a crane is used to lift the machine, ensure that the lifting cable is properly attached to the machine.
5. Do not forget to include the equipments originally furnished including the shock absorption steel plates and the instruction manual.

OPERATING INSTRUCTION

SAFETY PRECAUTIONS

BEFORE OPERATING

CONTROL PANEL

STANDARD ACCESSORIES

OPTIONAL ACCESSORIES

UNROLLING & INSTALLING THE BLADE

ADJUSTING WIRE BRUSH

PLACING WORKPIECE ONTO WORKBED

POSITIONING WORKPIECE FOR CUTTING

ADJUSTING BLADE SPEED

ADJUSTING COOLANT FLOW

BREAKING-IN THE BLADE

TEST-RUNNING THE MACHINE

CUTTING OPERATION

STARTING AN AUTOMATIC OPERATION

USING TOP CLAMP FOR BUNDLE CUTTING

TERMINATING A CUTTING OPERATION

SAFETY PRECAUTIONS

For your safety, please read and understand the instruction manual before you operate the machine.

The operator should always follow these safety guidelines:

- The machine should only be used for its designated purpose.
- Do not wear gloves, neckties, jewelry or loose clothing/hair while operating the machine.
- For eye protection, always wear protective safety glasses.
- Check the blade tension and adjust blade guides before starting the machine.
- Use auxiliary clamping or supporting devices to fix material in place before cutting long workpieces. Always make sure the material is clamped firmly in place before starting to cut.
- Do not remove jammed or cut-off pieces until the blade has come to a full stop.
- Keep fingers away from the path of the blade.
- Protection devices should be in place at all times. For your own safety, never remove these devices.
- Disconnect machine from the power source before making repairs or adjustments.
- Wear protection gloves only when changing the blade.
- Do not operate the machine while under the influence of drugs, alcohol or medication.
- Do not take your eyes off the machine while in operation.
- Do place warning signs to mark out machine work zone and restrict entry to be staff-only.

BEFORE OPERATING

Choosing an appropriate saw blade and using the right cutting method is essential to your cutting efficiency and safety. Select a suitable saw blade and cutting method based on your work material and job requirements e.g. cutting accuracy, cutting speed, economic concern, and safety control.

Wet cutting

If you choose dry cutting or low-speed cutting, the chips may accumulate in machine parts and may cause operation failure or insulation malfunction. We suggest you choose wet cutting to avoid machine damage.

Cutting unknown materials

Before cutting an unknown material, consult the material supplier, burn a small amount of chips from the material in a safe place, or follow any other procedure to check if the material is flammable.



Never take your eyes off the machine while in operation.

Cutting fluid

For cooling and lubrication purpose, we recommend you use water-soluble cutting fluids. The following table lists out its pros and cons for your reference.

Pro	Con
<ul style="list-style-type: none">• Have a high cooling effect• Not flammable• Economical• Does not require cleaning of the cut products	<ul style="list-style-type: none">• Remove machine paint• Lose its rust protection effect if deteriorated• Tend to create foam• Subject to decay• Decline in performance, depending on the quality of the water used for dilution



Never use water as your coolant.



Always add coolant into water for better mix result.



Consult your coolant supplier for bandsaw use regarding coolant type and mix ratio.



Before starting a cutting job, make sure there is sufficient amount of coolant in the tank.

Check the fluid level through the sight gauge. Please refer to machine specifications in this manual (Section 2) for tank capacity.

CONTROL PANEL

The control panel is located on the top of the electrical box. It includes the following function: power system, hydraulic system, cooling system and the human-machine-interface (HMI). The operator must fully understand the function of each switch and button before operating the machine.

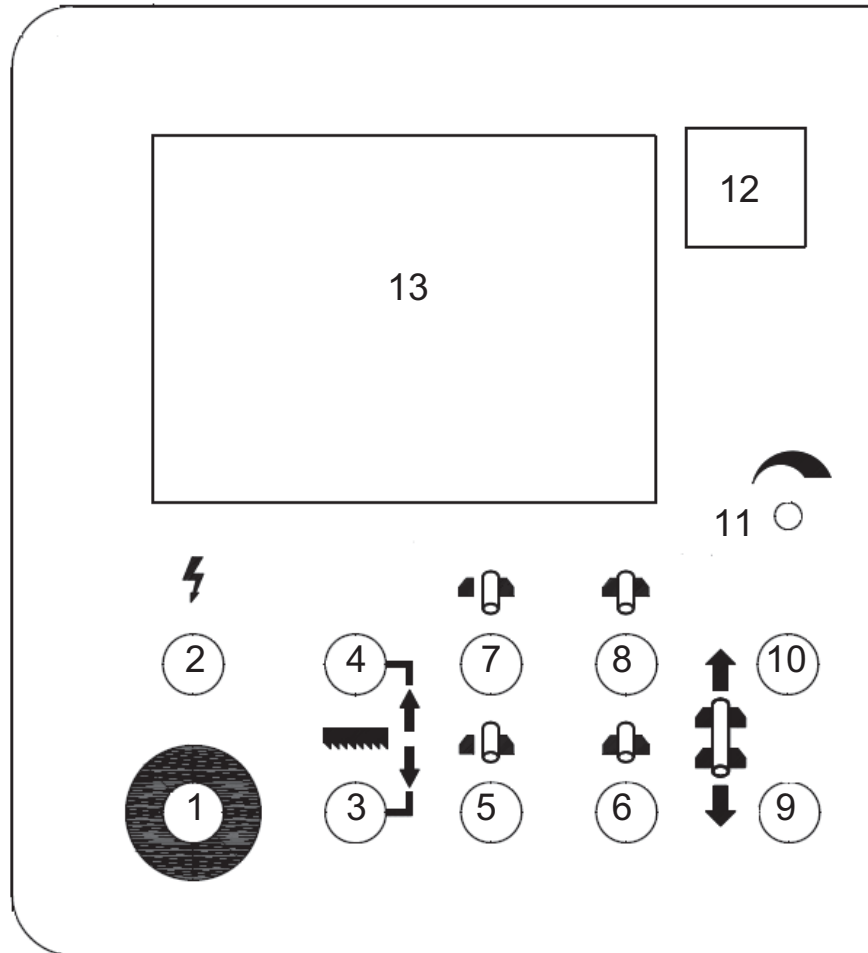

No.	Name	No.	Name
1	Emergency stop button	8	Rear vise clamp
2	Power indicator lamp	9	Feed forward
3	Saw bow down	10	Feed backward
4	Saw bow up	11	Blade speed control knob
5	Front vise open	12	Amp gauge
6	Front vise clamp	13	HMI touch screen
7	Rear vise open		

Control Buttons

1. Emergency stop button

Press this button to stop the machine in an emergency. When the button is pressed, it brings the machine to a full stop. The button locks when pressed. In order to unlock it, please turn the button clockwise.

2. Power indicator lamp

When the lamp is on, it indicates the power to the machine is turned on.

3. Saw bow down

When this button is pressed, the saw bow descends.



Before lowering the saw bow, the guide arm must be positioned outside the vise in order to avoid hitting the vise and causing damages.

4. Saw bow up

When this button is pressed, the saw bow rises until the operator lets go of the button or until the saw bow touches the upper limit switch.



While pressing the saw bow up button can stop the running blade, please still make use of the emergency stop button in an emergency.

5. Front vise open

This button only works when the machine is switched to manual mode .



If the saw bow is not above the middle limit switch, the front vise can only be opened in small increments, so as to prevent the vise from hitting the guide arm.

6. Front vise clamp

This button only works when the machine is switched to manual mode .

7. Rear vise open

This button only works when the machine is switched to manual mode .

8. Rear vise clamp

This button only works when the machine is switched to manual mode .

9. Feed forward

- When this button is pressed, the feeding workbed will move forward. Press and hold the button to feed forward. As soon as the button is released, the feeding workbed will stop moving forward.
- This button only works when the machine is switched to manual mode .
- This button is only in function when the quick approach bar is touching the upper limit switch AND when either of the front and rear vises are unclamped.



After the blade motor starts running, the function of rear vise is disabled due to safety concerns.

10. Feed backward

- When this button is pressed, the feeding workbed will move backward. Press and hold the button to feed backward. As soon as the button is released, the feeding workbed will stop moving backward.
- This button only works when the machine is switched to manual mode .
- This button is only in function when the quick approach bar is touching the upper limit switch AND when either of the front and rear vises are unclamped.



After the blade motor starts running, the function of rear vise is disabled due to safety concerns.

11. Blade speed control knob

Blade speed is controlled by the inverter located under the workbed. Turning the knob clockwise increases the blade speed.

12. Amp gauge

Amp gauge displays current in ampere.

13. HMI touch screen

Please refer to later section for detailed introduction.

Blade Descend Pressure and Speed

The part of control panel is where cutting pressure and saw bow descend speed can be adjusted.

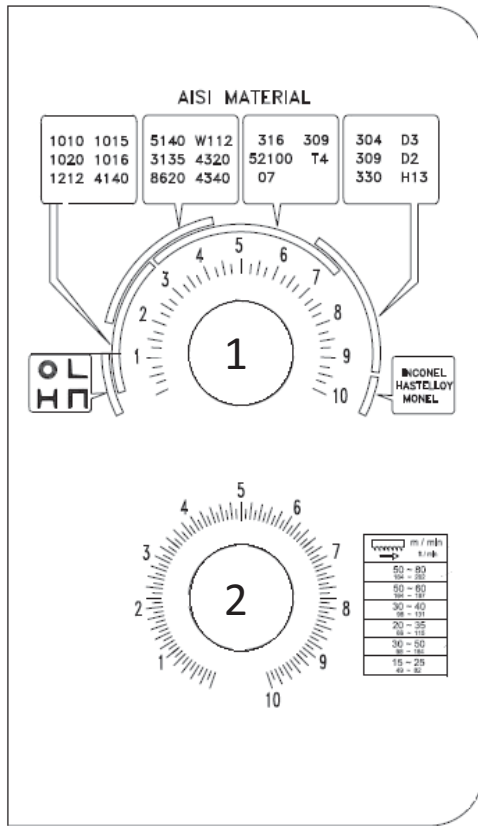

Cutting pressure and speed control panel

1. Cutting pressure control knob

- This pressure control knob is used to adjust the cutting pressure of the blade.
- Turning the knob clockwise increases the cutting pressure.
- To obtain a good cutting result, choose the right cutting pressure by turning the knob until it points to your material on the color chart.

2. Blade descend speed control knob

- This knob is used to adjust the descend speed of the saw blade.
- Turning the knob clockwise increases the blade descend speed.
- Blade descend speed is a determining factor to a good cutting time and quality cutoff surface.
- Set the blade descend speed in accordance with the *cutting pressure control* knob.
- Also commonly known as the flow control valve

Human-Machine-Interface (HMI) Touch Screen

This HMI touch screen displays operation messages so that the operator is able to understand the system condition. It also provides different operating modes and selections for the operator to work with. During a cutting job, the operator can still enter the system and make changes to the cutting operation as needed.



Do not wipe or clean the screen with volatile solvents.



Do not overexert pressure on the screen. The touch screen is very sensitive; all buttons on the screen just need a slight touch to operate.



All range parameters in HITECH 5.7" are configured under the "manual" mode.



Please pay attention to the following environment conditions necessary for HITECH 5.7" HMI touch screen to properly operate:

Item	Range
Ambient temperature	5°C ~ 50°C
Temperature for safe operation	-10°C ~ 60°C
Ambient humidity	30%~85% RH (No condensation)
Connection	RS422 MMI port
Environment	No condensation and rust



Startup Screen







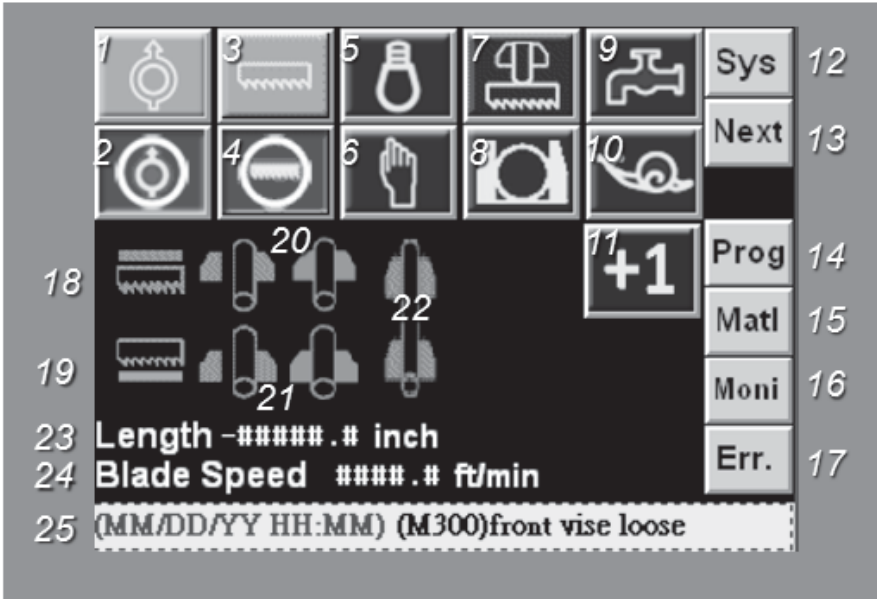





After the power is turned on, Cosen’s logo will appear as the startup screen, followed by the main operation menu..













Main control menu













The main control menu includes some operating button that were used on the control panel of the earlier machines. Some convenient functions are added to the page for the operator to better understand the features of the machine. Setting the parameters shown on the screen requires a gentle touch of the finger. You can also look up the parameters or make changes while in the middle of a cut.









Refer to the table below for descriptions of each function.

No	Item	Function	Description
1		Hydraulic start	<p>When the power is turned on, press this button to start the hydraulic motor.</p> <p>A solid yellow icon indicates the hydraulic system has been turned on. </p>
2		Hydraulic stop	<p>Press this button to turn off the hydraulic motor immediately.</p> <p> When the blade is running, the Hydraulic Stop button is temporarily disabled. You need to press the <i>saw blade stop</i> or the <i>saw bow up</i> button to stop the blade first.</p>
3		Blade start	<p>When the work piece is clamped properly, press this button to start cutting.</p> <p>A solid yellow blade icon indicates the blade has been started. </p>
4		Blade stop	Press this button to stop the blade.
5		Work light ON/OFF	<p>Press this button to turn on the work light.</p> <p>The light bulb showing a solid yellow icon indicates the worklight has been turned on. </p>
6	 	AUTO / Manual mode	<p>Use this button to switch between automatic and manual mode.</p> <ul style="list-style-type: none"> ● AUTO mode: used to automatically perform continuous cutting jobs. When switched to this mode, the machine will automatically operate according to the preset parameters. ● Manual mode: used to perform individual cutting job. When switched to the Manual mode, you can execute each individual function. <p> <i>Trim Cut</i> - When the machine is switched from the Manual mode to the AUTO mode, the first cut (trim cut) will not be counted into finished cuts and the machine will continue to operate according to the preset parameter. This function allows the machine to finish the trim cut and directly proceed into automatic cutting till the last cutting job.</p> <p> If you switch to manual mode while cutting is already in action under AUTO mode, the machine will stop after the</p>

No	Item	Function	Description
			individual cut is finished. Switching to manual mode at any time other than cutting, the machine will proceed with the next cut until it is finished.
7		Material retract 2mm ON/OFF	<p>When this function is turned on, the machine will retract the material for 2mm after completing each cut before the blade rises from its lowest position.</p> <p>A solid yellow icon indicates the <i>Material retract 2mm</i> mode has been turned on. </p>
8		Single/Bundle cutting mode	<p>This button is used to switch between single or bundle cutting mode.</p> <ul style="list-style-type: none"> ● Switch to single cutting model () to cut a single work piece. ● Switch to bundle cutting mode () to cut a stack of work pieces. <p> When under bundle cutting mode, the feeding vise must be touching the front limit switch for the blade to be able to start.</p>
9		Coolant ON/OFF	<p>Press this button to turn on the coolant pump.</p> <p>A solid yellow faucet icon indicates the coolant pump has been turned on. </p> <p>Press again to turn off the coolant pump.</p>
10		Slow material feeding mode	<p>Used only when under Manual mode.</p> <p>When the slow material feeding mode is turned on, the material feeding speed will dramatically reduce to help you position the work piece precisely.</p>
11		Trim cut ON/OFF	<p>This selection button works with the AUTO mode.</p> <p>When under AUTO mode and before proceeding with your automatic cutting jobs, select  if you wish the first cut to be “trim cut” i.e. trimming the edge of your material without the cut being counted into the “finished cuts.”</p> <p>In the other hand, select  if you do not need to trim cut the material. The first cut will then be counted as the first cut of your programmed jobs.</p> <p> After the first cut begins, you may still change your selection before the saw bow has descended to its lowest point.</p>

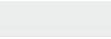
No	Item	Function	Description
12		System parameter setting	<p>Press this button to set up system parameters. Password is required.</p> <p> All parameters have been set up by the manufacturer. In order to prevent random change from being made to these parameters and affect cutting precision and machine life, this function is protected with a set of password.</p>
13		Cutting parameter setting	<p>Press this button to display cutting-related information e.g. total number of cuts completed and feeding length OR to set parameters e.g. cutting lengths and quantity. (A total of 100 cutting programs can be set.)</p> <p>Blade deviation detector (optional) can be also configured in this setup page.</p> <p>Refer to Cutting Display & Setup in the following page.</p>
14		Cutting program setting	<p>Press this button to directly enter the cutting job program setup page.</p> <p>A total of 100 cutting programs can be set.</p>
15		Material cutting reference	This 2-page reference chart lists out the required blade speed and cutting rate for each different material.
16		PLC monitor	Shows current PLC signals.
17		Error report	Lists a historical report of the errors and the time of occurrence as well as provides troubleshooting support. 6 pages in total.
18		Saw blade up indicator	<p>Indicates that the saw blade is rising.</p> <p>When activated, the saw blade icon will turn solid white.</p> 
19		Saw blade down indicator	<p>Indicates that a cut is completed and the saw blade is at its lowest position.</p> <p>When the blade completes each cut and triggers the lower limit switch, the saw blade icon will turn solid white.</p> 
20		Rear vise status indicator	<p>Indicates if the rear vises have clamped and secured the workpiece.</p> <p>When the rear vises have secured the workpiece, the clamping vise icon on the right will turn solid white.</p> 



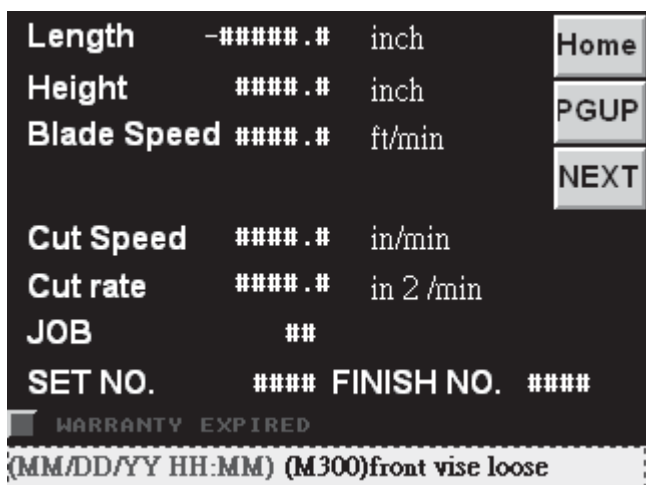

No	Item	Function	Description
21		Front vise status indicator	Indicates if the front vises have clamped and secured the workpiece. When the front vises have secured the workpiece, the clamping vise icon on the right will turn solid white. 
22		Feeding movement indicator	When the feeding vise reaches the front limit, the vise set icon will turn solid white. 
23	Length	Feeding length display	Displays current feeding length while the material is being fed.
24	Blade Speed	Blade speed display	Displays current blade speed.
25	 (yellow highlight)	Error display	Displays error messages in the order of occurrences; press the message for one second to clear the messages.  The message must be cleared for the machine to continue to operate normally.

Cutting status display & setup

When cutting is in operation, press  to enter cutting status display and setup page.



Page 1 – cutting status display

- This page shows the following information (from top to bottom):
 - Feeding length (current feeding vise position)
 - Blade height
-  This function is available only if the optional height encoder is equipped with the machine.
 - Blade speed
 - Current blade descending speed (optional)
 - Cut rate (available only if the optional saw bow height encoder is equipped on the machine)
 - Deviation value (optional)
 - Number of current cutting job/step in operation
 - Preset quantity of current cutting job
 - Number of cuts finished
 - The green square light on the bottom left corner indicates the warranty status of the HMI touch screen. Warranty is one year and starts counting after 70 hours of operation after the machine is shipped. Warranty status light turning to red indicates the HMI touch screen has expired.
 - Error messages (highlighted in yellow; can be cleared by pressing down for one second)
- Press  to return to the main control menu.
- Press  to go back to the previous setup page.
- Press  to go to the next setup page.

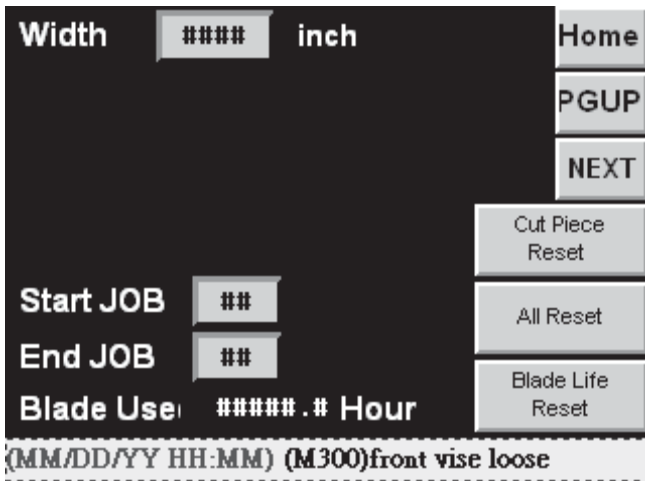

(Display without optional blade deviation detector included)

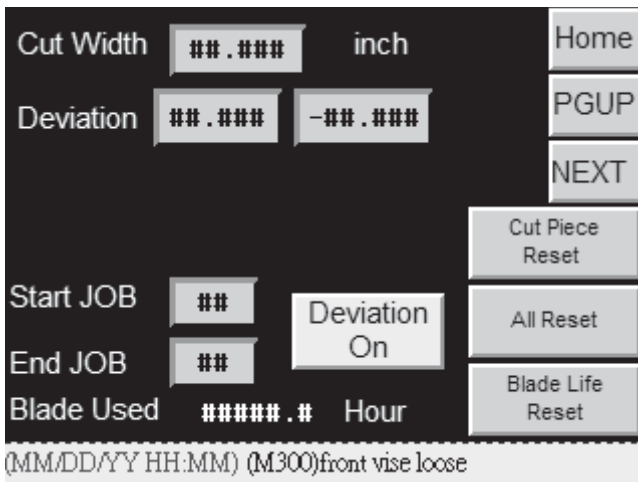

(Display with optional blade deviation detector included)

Page 2 – cutting status setup

This page comes in two versions depending on if the optional blade deviation detector is installed on the machine. The shared features are as follows:

- **Width** - Set material width so the system can automatically calculate the cut rate.
- **Start JOB** – Key in the number of the job you wish to execute first under automatic mode.
- **End JOB** – Key in the number of the job you wish to execute last under automatic mode.
- Current blade life in hours
- **Cut Piece Reset** - Reset all *Cuts Finished* data by pressing this button for three seconds.



If you start a new set of program without clearing cutoff data from previous job, the first cut (trim cut) will be skipped as the second program is deemed as the succeeding part of the previous program.

- **All Reset** - Reset all preset cutting data within *Starts Step* and *Ends Step* by pressing this button for three seconds.
- **Blade Life Reset** - Reset the blade life to zero
- Error message (bottom of page)
- Press **Home** to return to the main control menu.
- Press **PGUP** to go back to the previous setup page.
- Press **NEXT** to go to the next setup page.

For machines with optional blade deviation detector installed, additional two commands are provided:

- **Deviation** - Set deviation tolerance value based on the precision requirement of your material.



During cutting, if the blade deviation is greater than the set values, the saw blade will be stopped to protect the blade.

- **Deviation ON/Off** - Turn on or turn off the deviation detector if installed.

JOB	Length	Quantity	Cut Finished	Home
00	#####.#	####	####	PGUP
01	#####.#	####	####	Next
02	#####.#	####	####	P01
03	#####.#	####	####	P05
04	#####.#	####	####	P10
05	#####.#	####	####	P15
Start JOB	##	End JOB	##	cut reset

Page 3 – cutting program setup

- In this page you can set your desired cutting length and quantity and see the number of finished cuts (*Cut Finished*).
- A total of 100 cutting jobs can be set and performed under the automatic mode.
- In “start job” and the “end job” field, fill in the number of the cutting job you wish to start and end with. The machine will automatically perform cutting jobs within this range.
- In *Length* column, set each respective cutting length in mm or inch.
- In *Quantity* column, set each respective cutting quantity.
- Press **cut reset** button for 3 seconds to reset the cutoff quantity.



If you start a new set of program without clearing cutoff data from previous job, the first cut (trim cut) will be skipped as the second program is deemed as the succeeding part of the previous program.

- Press **Home** to return to the main control menu.
- Press **PGUP** to go back to the previous setup page.
- Press **Next** to go to the next cutting program setup page.
- Press **P01**, **P05**, **P10**, **P15** to quickly jump between cutting programs (Job 00 ~ 99)

Prog Cutting program setup

When cutting is in operation, press **Prog** to quickly access the cutting program setup page (the same as page 3 of the cutting status display and setup page)

JOB	Length	Quantity	Cut Finished	Home
00	#####.#	####	####	PGUP
01	#####.#	####	####	Next
02	#####.#	####	####	P01
03	#####.#	####	####	P05
04	#####.#	####	####	P10
05	#####.#	####	####	P15
Start JOB	##	End JOB	##	cut reset

This setup page is the same as page 3 of the cutting status display and setup page.

Mtrl Material cutting reference

THE TABLE OF CUTTING RANGE < JIS >			Home
MATERIAL	BLADE	CUTTING RATE	
01 S20C-S35C	65 - 90	70 - 108	
02 S40C-S50C	65 - 90	70 - 100	
03 S9CK-S15C	80 - 110	60 - 90	
04 S53C-S58C	65 - 90	60 - 80	
05 SS50	65 - 90	60 - 70	Next
06 SS41	65 - 90	55 - 70	
07 SM50	54 - 50	50 - 56	
08 SCM3	54 - 80	65 - 80	
09 SUP5	54 - 80	40 - 55	
10 SRC 3,4	54 - 80	40 - 55	
11 SCMM22	54 - 80	40 - 50	
12 SNC1	54 - 80	40 - 50	
13 SNC22	54 - 80	35 - 45	
14 SNCMM22	54 - 80	35 - 45	

- This 2-page reference chart lists out the required blade speed and cutting rate for each different material.

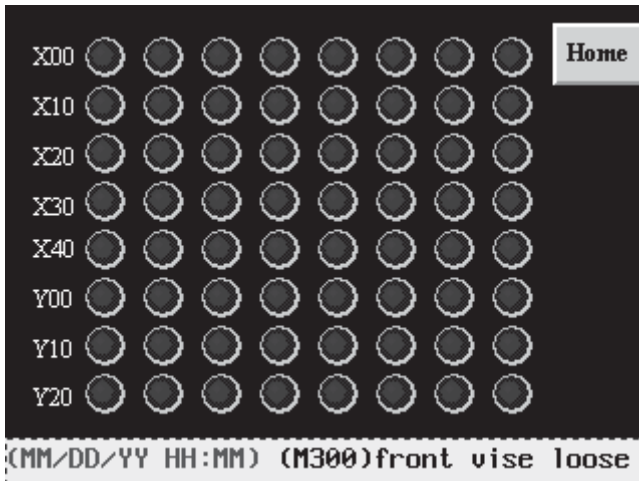

- Shows all signals of the PLC system.

Err. **Error report**

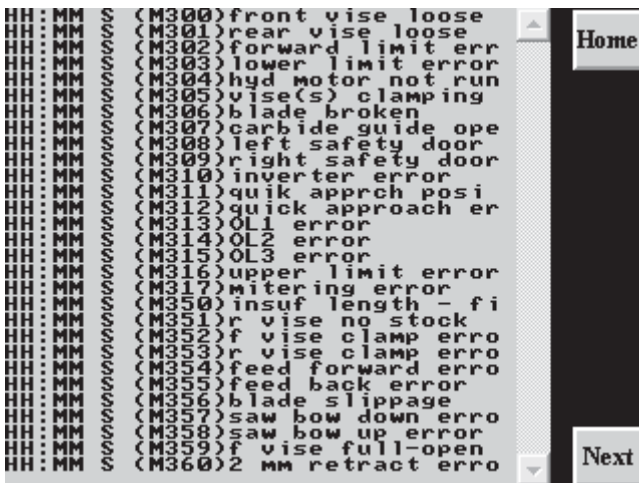

Page 1 – error report

- Lists a historical report of the errors and the time of occurrence.
- Press **Home** to return to the main control menu.
- Press **Next** to go to the troubleshooting support page.

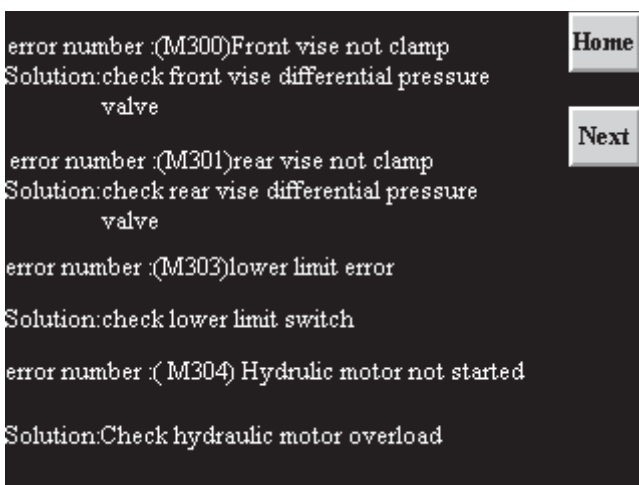

Page 2 – troubleshooting



- Provides suggestions on troubleshooting. 6 pages in total.
- Also refer to the Table 4.1 for error codes, descriptions and solutions.
- Press **Home** to return to the main control menu.
- Press **Next** to go to the troubleshooting support page.

Error Code	Error Description	Solution
M300	Front vises not clamping	Check if the queen valve works
M301	Rear vises not clamping	Check if the queen valve works
M303	Lower limit switch error	Check if the lower limit switch works
M304	Hydraulic motor not starting	Check if the hydraulic motor works
M306	Broken blade detected	1. Check if the speed switch works 2. Check if the blade is broken
M308	Left safety door abnormal	1. Check if the left safety door is shut properly 2. Check if the left safety door limit switch works
M309	Right safety door abnormal	1. Check if the right safety door is shut properly 2. Check if the right safety door limit switch works
M312	Quick approach bar abnormal	Check if the quick approach limit switch works
M313	OL1 abnormal	Check if the blade motor overload relay has tripped
M314	OL2 abnormal	Check if the hydraulic motor overload relay has tripped
M315	OL3 abnormal	Check if the coolant pump motor overload relay has tripped
M316	Saw bow upper limit abnormal	Check the upper limit switch works
M352	Front vise clamping error	1. Place new material 2. Check if the vise queen valve works 3. Check if the “no material parameter” is too low
M357	Saw bow descending error	1. Check if the descend solenoid valve is stuck 2. Check the quick approach bar works 3. Check if the quick approach bar limit switch works
M358	Saw bow ascending error	1. Check if the ascend solenoid valve is stuck 2. Check the quick approach bar works 3. Check the quick approach bar limit switch works
M361	No material	1. Place new material 2. Check if the vise queen valve works 3. Check if the “no material parameter” is too low
M363	PLC battery voltage too low	Replace PLC battery

STANDARD ACCESSORIES

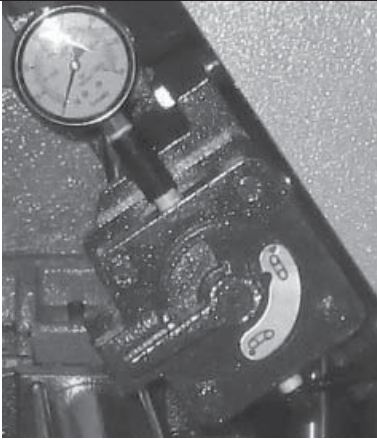
Blade tension device



- This blade tension device equipped with hydraulic cylinder provides appropriate tension to the saw blade.
- To tighten the saw blade, turn the selector to .
- Upon saw blade breakage, the safety device will activate and automatically stop all machine operation.
- The limit switch of the safety device can be reset by turning the blade tension selector to .
- To change the blade, turn the handle to  to release saw blade tension.



Never adjust blade tension while the blade is running.

Blade speed/motion detector

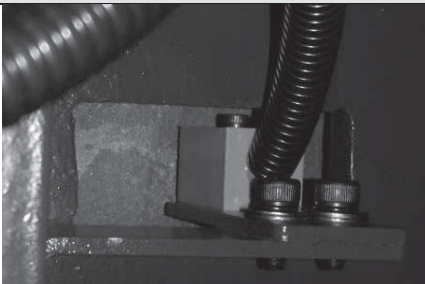

- Besides detecting the blade speed, the speed/motion detector also functions as a safety device.
- The speed/motion detector protects operators and the machine by preventing blade overloads and consequent damages if a saw blade breaks or skids.
- Once blade breakage or slippage is detected, the drive wheel will stop in 10 seconds.

Inverter



- This inverter is installed inside the electrical compartment. It is used to control and stabilize the saw blade speed during cutting.
- To adjust blade speed, use the blade speed control knob on the control panel.



Note:

1. Make sure the terminal points are connected.
2. Make sure the ambient temperature is within acceptable range and keep the surroundings well ventilated.
3. Keep the inverter away from dust.
4. For repair or maintenance, please contact your local agent.

Quick approach device

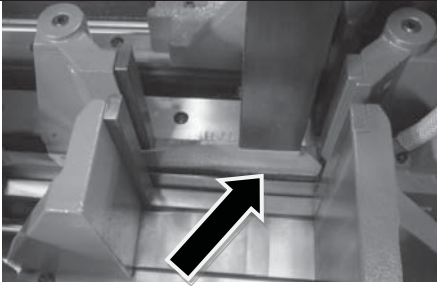

This device allows the blade to quickly descend to just right above the material to save you operation time.

Split front vises

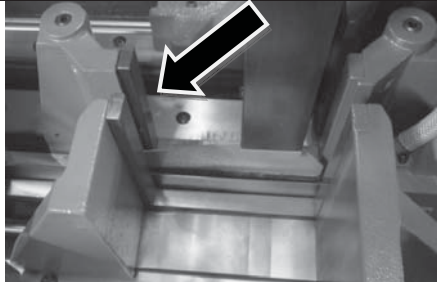

The split vises are a clever design to make sure your workpiece is tightly clamped by the two vises from both sides of the blade, maximizing stability and cutting precision.

Gear reducer

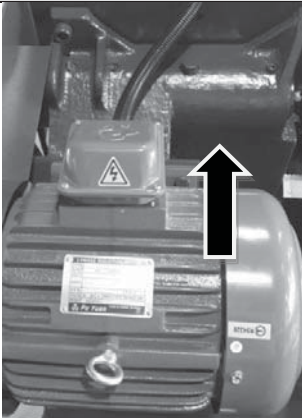

The specially designed gear reducer can work toward your preset blade speed and torque.



Please refer to Section 8 for information on maintenance.

Coolant pump



When the hydraulic system is turned on, the coolant pump can be operated individually from the control panel. Coolant can be used to wash off chips as well as providing cooling during cutting.

Vibration damper

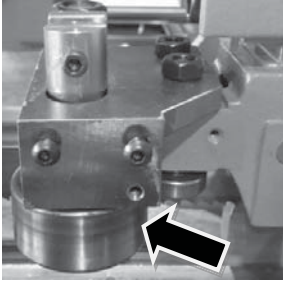

The vibration damper can be assembled to the left saw arm. This optional accessory is extremely useful in reducing the high-frequency noise produced when cutting large-sized material.

OPTIONAL ACCESSORIES

Vise pressure regulator

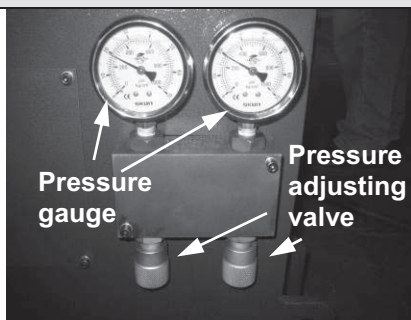

- This adjustment valve is used to control vise pressure.
- Adjust vise pressure based on the material of your workpiece.
- When cutting pipes or soft materials, reduce vise pressure to prevent exerted pressure from damaging the workpiece shape or exterior.



Vise pressure should never be lower than 8 kg/cm².

Chip conveyor



Chip conveyor is a spiral device to bring chips out during cutting.



As a regular maintenance, remove the chip conveyor and clean all chip deposits inside.

Hydraulic top clamps

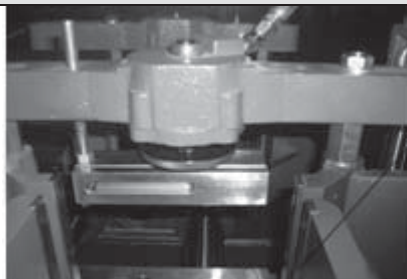

Multi Vise connector



- The top clamp device composed of two clamps is installed on top of the front and rear vises before executing bundle cutting.
- Refer to *Using Top Clamp for Bundle Cutting* for operating procedure on bundle cutting.

2M roller table

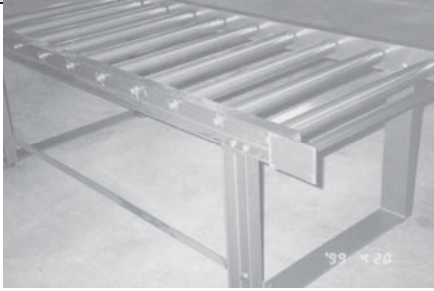

- The optional 2M roller table supports the work material and ensures the material be fed in smoothly.
- Refer to Section 9 for further information on adjusting the roller table.

Blade Deviation Detector

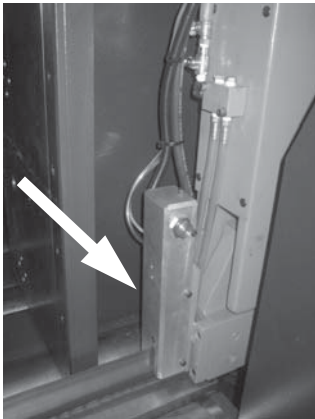

This device detects blade deviation. If the blade deviates beyond the preset range, the machine will stop automatically. When this device is installed, the cutting width will be reduced. The blade deviation detected value and preset values are displayed on the control panel screen.

Height encoder



With this optional device, the operator can input work piece width via HMI touch panel. When cutting begins and the blade starts to descend, the panel will display the current blade height, the blade descend speed and the cutting rate calculated by the system.



The encoder is a high-precision electronic device. It has been factory-adjusted before shipment. Please do not make any random change to it.



Avoid high impact on the device.

UNROLLING & INSTALLING THE BLADE



Always wear leather gloves and protection glasses when handling a blade.

Unrolling the blade

Please follow the procedures illustrated below.

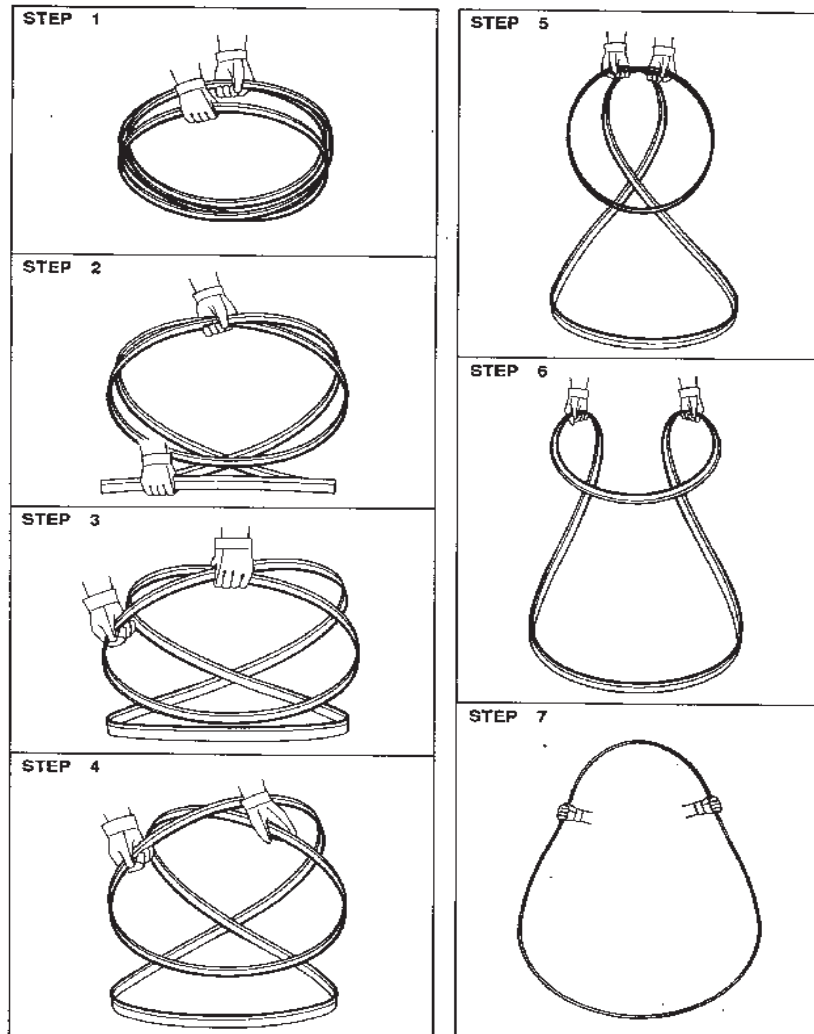

Unroll and roll the blade

Installing a new blade

Step 1 - Select the most suitable saw blade for your workpiece considering the size, shape and material.

Step 2 - Turn on the machine power by switching to *ON*.

Step 3 - Switch to *manual* (👉) mode.

Step 4 - Press the *saw bow up* button and elevate the saw bow until it reaches to its highest point.

Step 5 - Turn the tension controller handle from “○○” to “○○” position to release tension. The idle wheel will then move slightly toward the direction of the drive wheel.

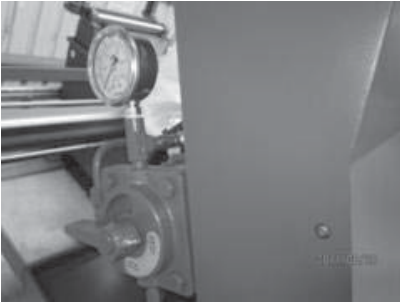

Step 6 - Open the idle and drive wheel covers.

Step 7 - Press the *Blade Clip* device to hold onto the blade. This device makes blade changing easy and feasible even with only one operator available.

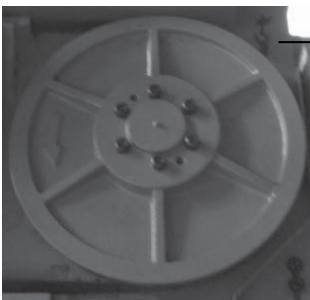

Easy Blade Replacement Device

Step 8 - Loosen the left and right carbide inserts by loosening the “lock nut” shown below.

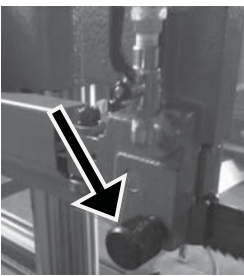

Step 9 - Open the wire brush cover. Loosen the lock lever and lower the wire brush.

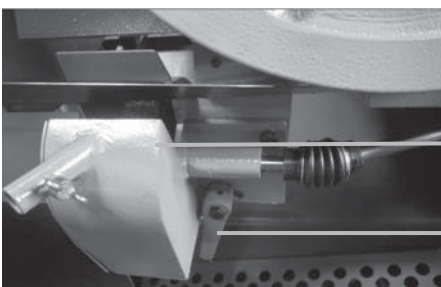

Wire Brush Case

Lock Lever

Step 10 - Remove the old blade. If necessary, clean the carbide inserts before installing a new saw blade.

Step 11 - Place the new blade around the idle wheel and the drive wheel.

Step 12 - Insert the blade into the left and right tungsten carbide inserts. The back and the sides of the blade need to be touching the inserts as well as the adjacent rollers.

Step 13 - Place the blade to the drive wheel and press the back of the blade against the flange of the drive wheel. Use the *Blade Clip* device to tightly hold the blade from falling out of the drive wheel.



When saw blade begins to rotate, the blade holder will automatically release the blade and fall back to its original position.

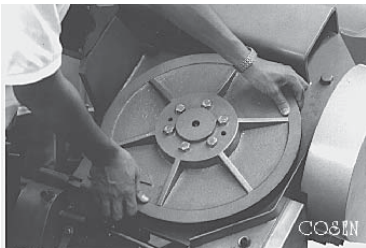

Step 14 - Make sure the back of the blade is also pressed against the flange of the idle wheel.

Step 15 - Turn the tension controller handle to [] position to obtain blade tension.

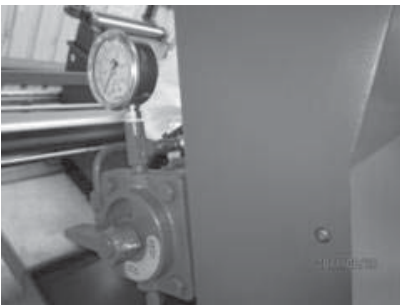

Step 16 - Make sure the sides of the blade are in close contact with the carbide inserts and then tighten the left and right carbide inserts by tightening the “lock nut.”

Step 17 - Gently close the idle and drive wheel covers.

Step 18 - Press the *saw blade start* button to start the blade. Allow the blade to run for a few rotations then press the *saw bow up* button to elevate the saw bow. Open the wheel covers and make sure the blade has not fallen off the drive and idle wheels. If the blade has shifted, follow the same procedure to reinstall the blade again.

Step 19 - Adjust wire brush to a proper position. Refer to *Adjusting Wire Brush* in this section.

ADJUSTING WIRE BRUSH

Follow these steps to adjust wire brush to appropriate position:

Step 1 - Loosen the lock lever and the wire brush cover.

Step 2 - Adjust the screw to make brush move up / down until it makes proper contact with the saw blade (see below illustration).

Step 3 - Reinstall the wire brush cover and tighten the lock lever.

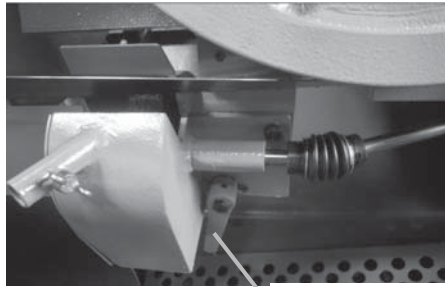

Lock Lever

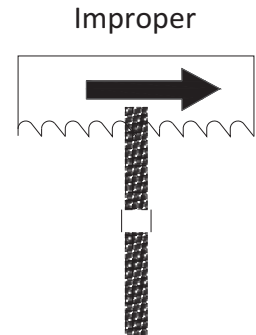
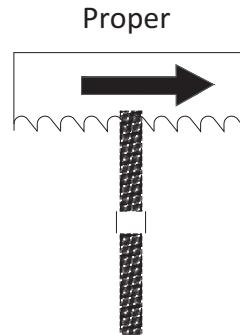

ADJUSTING SAW ARM

Adjust the blade guide (guide arm) position based on the size of your workpiece:

Step 1 – Loosen the inserts by unlocking the lock nut.

Step 2 – Loosen the blade guide locking lever. Then adjust the guide arm to a position suitable for your workpiece size.

Step 3 – After adjustment is made, tighten the blade guide locking lever.

Step 4 – Clamp the inserts back by tightening the lock nut.



Locking Lever

Inserts Lock Nut

ADJUSTING COOLANT FLOW

Step 1 – Press the *saw blade start* button to start the saw blade drive motor.

Step 2 – Press the *saw bow down* button to lower the saw bow.

Step 3 – Use the flow control valve (shown below) to adjust the amount of fluid flowing to the cutting area.

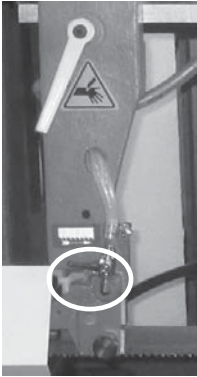

Adjust the flow amount if you observe the following changes to the chips generated from cutting.

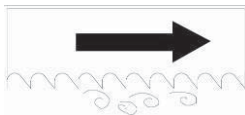

If the chips are sharp and curved, increase the coolant flow amount.

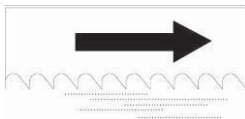

If the chips are granulated, decrease the coolant flow amount.

PLACING WORKPIECE ONTO WORKBED

Step 1 – Press the *saw bow up* button and elevate the saw bow until it reaches to its highest point.

Step 2 – Press the *front vise open* and *rear vise open* buttons to open vises.

Step 3 – Loosen the vertical roller lock handles and fully open the vertical rollers.

Step 4 – Carefully place the workpiece onto the work feed table to where it extends approximately 30mm(1.2 inch) beyond the rear vise toward the front vise.

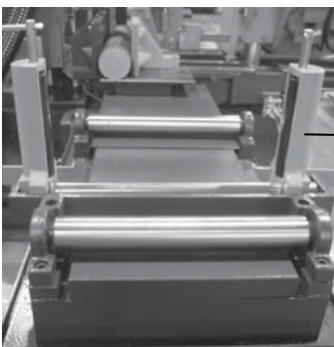

Vertical Roller

POSITIONING WORKPIECE FOR CUTTING

Follow these steps to position your workpiece:

Step	Action
rear vises clamp material	1 Press the <i>rear vise clamp</i> button until the workpiece is securely clamped.
align vertical rollers	2 Move the vertical alignment rollers toward workpiece until it stands against the workpiece. Lock the vertical alignment rollers by tightening the lock handles
feed material forward	3 Press the <i>feed forward</i> button until the rear vise touches the front limit switch.
front vises clamp material	4 Press the <i>front vise clamp</i> button until the workpiece is securely clamped.
rear vises retract to clamp material again	5 Press the <i>rear vise open</i> button.
	6 Press the <i>feed backward</i> button until the rear vises reach back limit switch.
	7 Press the <i>rear vise clamp</i> button until the workpiece is securely clamped again.
front vises open; prepare for precision position	8 Simultaneously press the <i>front vise open</i> button and the <i>rear vise clamp</i> button again to make sure the material is clamped.
confirm cutoff point	9 Press the <i>saw bow down</i> button to lower the saw bow until the quick approach bar descends to just about 10mm (0.4 inch) above the workpiece.  Under no circumstances should the quick approach bar be lowered below the height of the workpiece.
precision position	10 Press the <i>feed forward</i> button (and the <i>feed backward</i> button if necessary) until the cutoff point on the workpiece aligns with the blade line.
front vises clamp material; ready to cut	11 After the workpiece is correctly positioned, press the <i>front vise clamp</i> button so the workpiece is securely clamped.

ADJUSTING BLADE SPEED

Step 1 – Set the flow control to “0” position.

Step 2 – Press the *saw blade start* button to start the blade.

Step 3 – Turn the *blade speed control knob* to adjust the blade speed. The blade speed should be adjusted based on the size and the material of the workpiece.

BREAKING-IN THE BLADE

When a new saw blade is used, be sure to first break in the blade before using it for actual, extended operation. Failure to break in the blade will result in less than optimum efficiency. To perform this break-in operation, the following instructions should be followed:

Step 1 - Reduce the blade speed to one-half of its normal setting.

Step 2 - Lengthen the cutting time to 2-3 times of what is normally required.

Step 3 - The complete break-in operation requires cutting on a 645 mm² (25.4 square inches) section for 5 times.

Step 4- After the break-in operation is completed, set all parameters back to normal settings.

TEST-RUNNING THE MACHINE

Test-running this machine can ensure good machine performance in the future. We suggest you run the following tests on the machine before first use:

Testing machine performance:

Turn on the power and run a basic performance test after you finish installing the machine. Follow these steps to test machine performance:

Step 1 – Disassemble shipping brackets and bolts.

Step 2 – Install roller table (optional).

Step 3 – Turn on the relay switch in the control box.

Step 4 – Elevate the saw bow. (If your coolant pump is in reverse and the machine cannot run, please change the electrical phase.)

Step 5 – After the saw bow ascends, extend the quick approach device.

Step 6 – Remove the rust-prevention grease with cleaning oil or kerosene.

Step 7 – Start the coolant pump.

Step 8 – Test these functions under manual mode:

- vise clamping/unclamping
- saw bow ascending/descending
- feeding forward and backward

CUTTING OPERATION

Step 1 – Check before you cut

- **Power:** Check the voltage and frequency of your power source.
- **Coolant:** Check if you have sufficient coolant in the tank.
- **Hydraulic:** Check if you have sufficient (at least two-thirds or higher) hydraulic oil.
- **Workbed:** Check if there is any object on the feeding bed that may cause interference.
- **Blade:** Check the blade teeth and make sure there is no worn out teeth along the blade.
- **Light:** Check the work lamp or laser light (optional) and make sure there is sufficient lighting.
- **Roller:** Check all the rollers on the front and rear workbed can roll smoothly.
- **Saw bow:** Check the saw bow to see if it can be elevated and lowered smoothly.

Step 2 – Place your workpiece onto the workbed manually or by using a lifting tool e.g. a crane.



Before loading, make sure the vises are opened to at least wider than the width of the workpiece.

Step 3 – Position your workpiece.

Step 4 – Clamp the workpiece.

Step 5 – Turn the *cutting pressure control* knob to adjust cutting pressure according to the material.

Step 6 – Adjust *blade descend speed control* knob to obtain a suitable blade descend speed for your material.

Step 7 – Start running the blade.



Before you start cutting, check again that there is no other object in the cutting area.

Step 8 – While the blade descends, adjust the blade speed if necessary. You can do so by turning the *blade speed control* knob, clockwise to speed up and counterclockwise to slow down. The blade speed is displayed in the HMI touch screen.

Step 9 – Select the proper cutting condition according to different material.

Step 10 – After the entire cutting job is completed, elevate the saw bow to the top and open the vises to remove the workpiece.

Step 11 – Clean the workbed by removing chips and cutting fluids.

Step 12 – Lower the saw bow to a proper position then turn off the power.

STARTING AN AUTOMATIC OPERATION

- Step 1 – Use manual mode and cut the edge of the workpiece by using the same procedures as those described under manual operation.
- Step 2 – After the trim cut is completed and the saw blade has stopped at the lower limit position, press the *saw blade up* button to raise the saw bow until the quick approach bar is approximately 10mm (0.4inch) above the workpiece.
- Step 3 – Turn the *Auto / manual* switch to manual.
- Step 4 – Set your desired cutting length and quantity via the HMI touch screen. A total of 100 sets of cutting data can be programmed.
- Step 5 – Turn the *Auto / manual* switch to Auto.
- Step 6 – Press the *saw blade start* button and press the *saw bow down* button to start automatic cutting.

USING TOP CLAMP FOR BUNDLE CUTTING

Installing top clamp

To perform bundle cutting, use the top clamps and take the following installation procedures.

- Step 1 – Install stud bolts on the front and rear vises and position the top clamp.

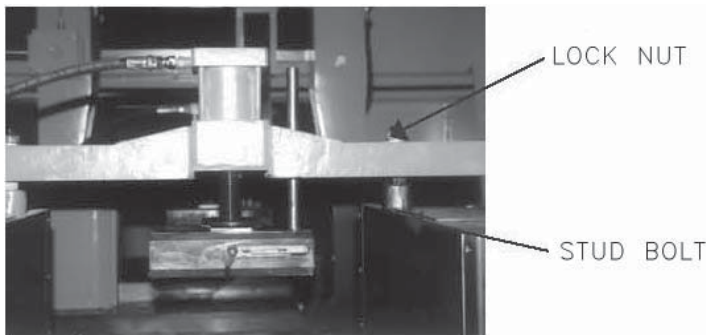

- Step 2 – Connect the top clamp hoses to the pressure joints on the vise hydraulic cylinders.

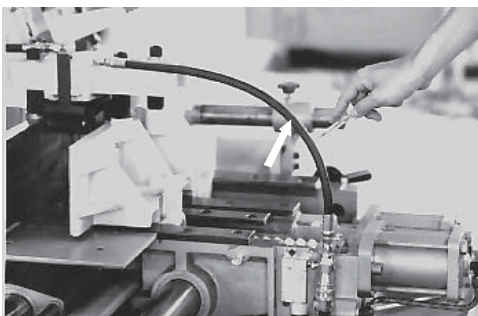

- Step 3 – Position the workpiece for bundle cutting.



Note the allowable clamping width and height. (Refer to *Section 2 – General Information, Specifications*)

Proper and improper stacking of workpieces

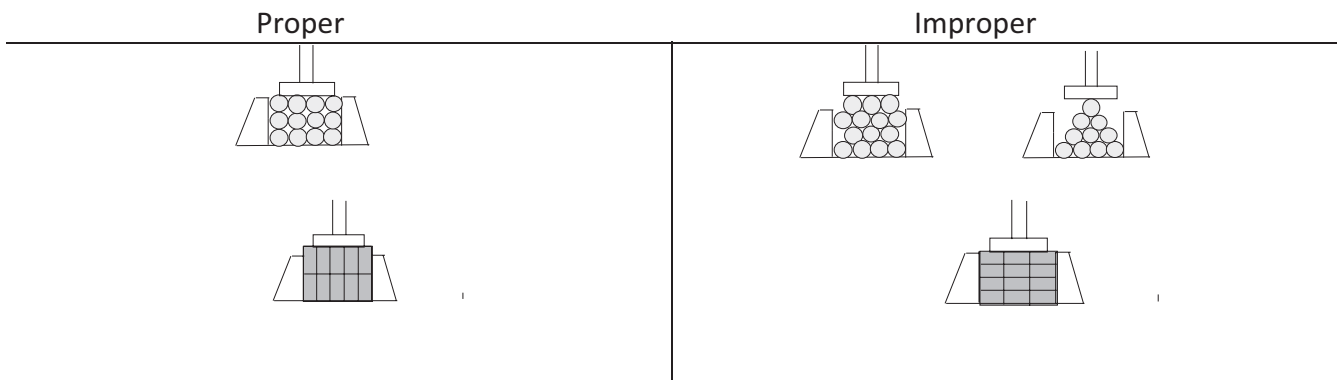

Step 4 – Align the top clamp cylinders with the center of the workpiece and tighten the lock nuts.

Step 5 – Turn the top clamp handles so that the clearance between the top clamp jaw and the top of the bundled workpiece is within 5 to 10 mm (0.2 ~ 0.4 in).

Step 6 – Install the bundle-cutting fence to the work tray. The fence is designed to prevent cut pieces from scattering across the work tray. Adjust the width of the fence to be slightly larger than the width of the bundle.

Step 7 – Press *Single/Bundle cutting mode* button and switch to bundle cutting mode.

Step 8 – For subsequent cutting procedures, refer to the instructions under manual operation and automatic operation.

Uninstalling top clamp

Follow these steps to uninstall top clamp for cutting single material:

Step 1 – Disconnect the top clamp hoses.

Step 2 – Loosen the lock nuts and remove the top clamp.

Step 3 – Remove the stud bolts.



TERMINATING A CUTTING OPERATION

- To terminate a cutting operation, press either the *saw bow up* button or the *emergency stop* button.
- The saw blade will stop running when the *saw bow up* button is pressed.
- Both the saw blade and hydraulic pump motors will stop running when the *emergency stop* button is pressed.
- The machine will stop automatically when an error occurs. The error message will be shown on the screen.

Section 5

ELECTRICAL SYSTEM

ELECTRICAL CIRCUIT DIAGRAMS

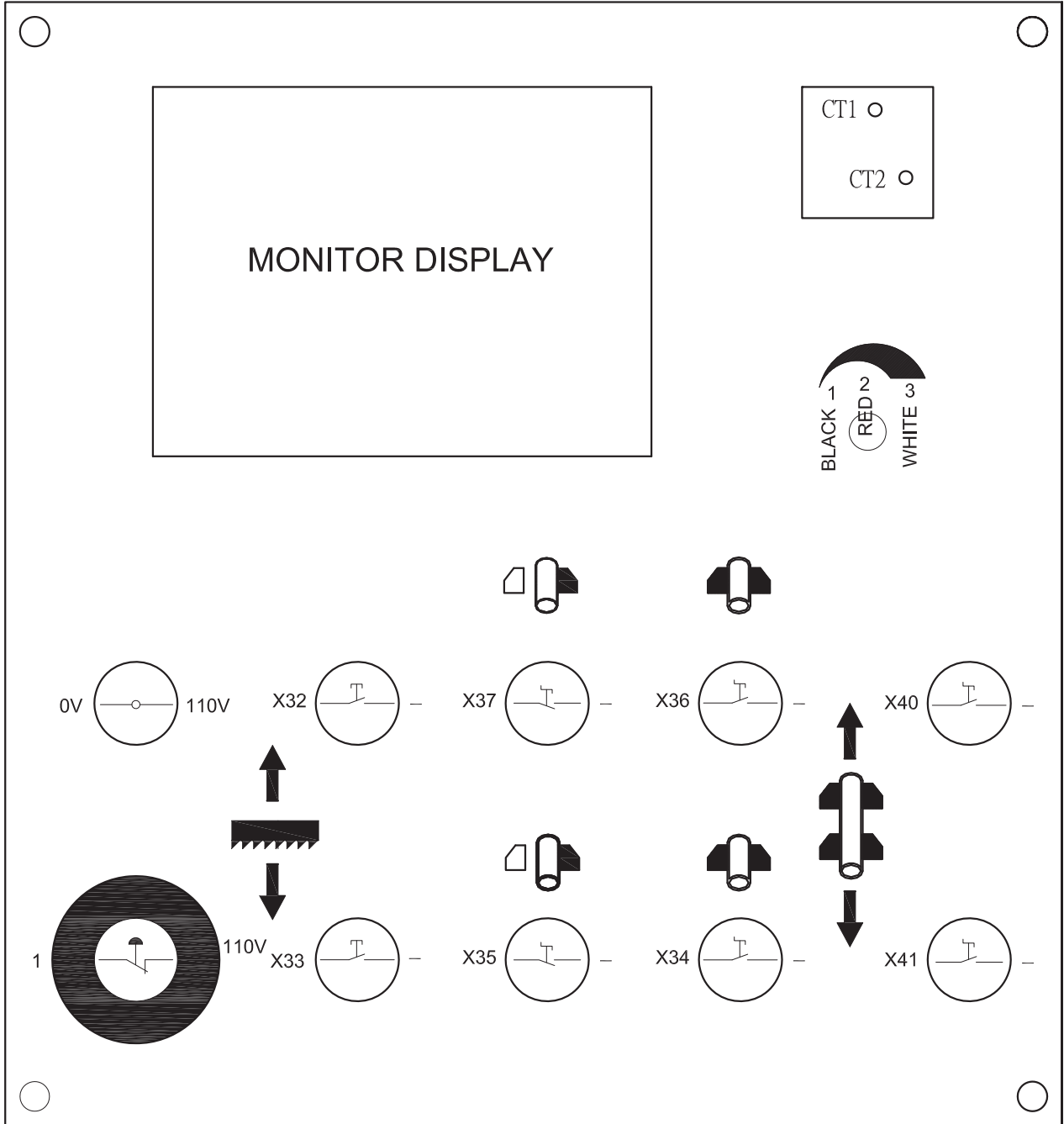

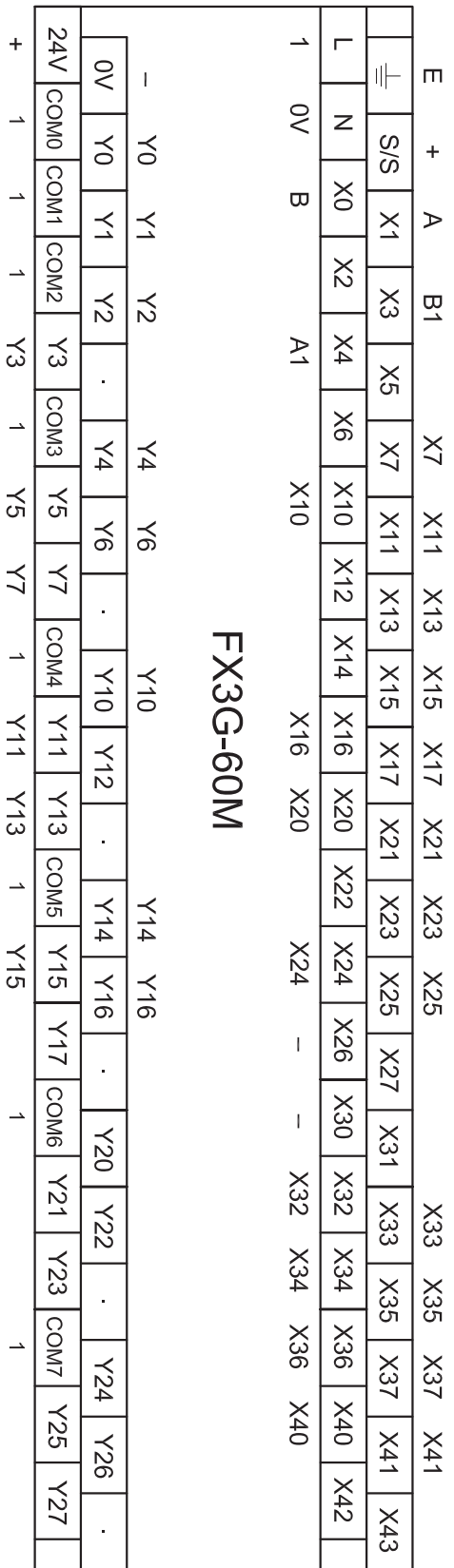

FX3G-60M

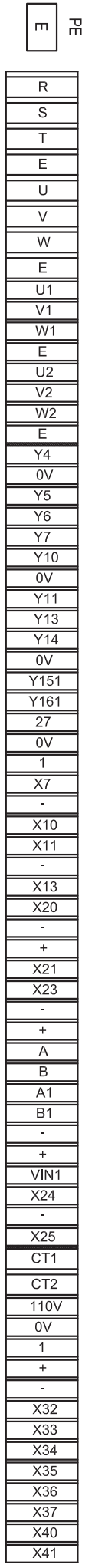
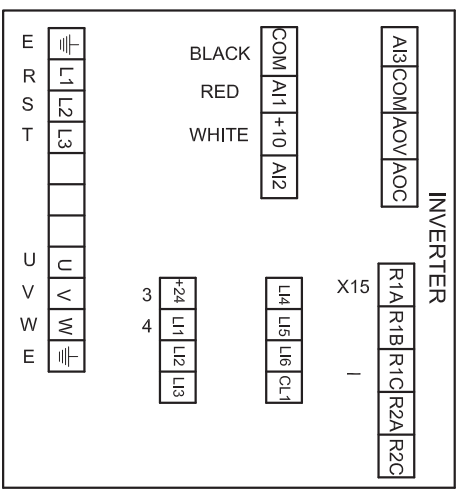
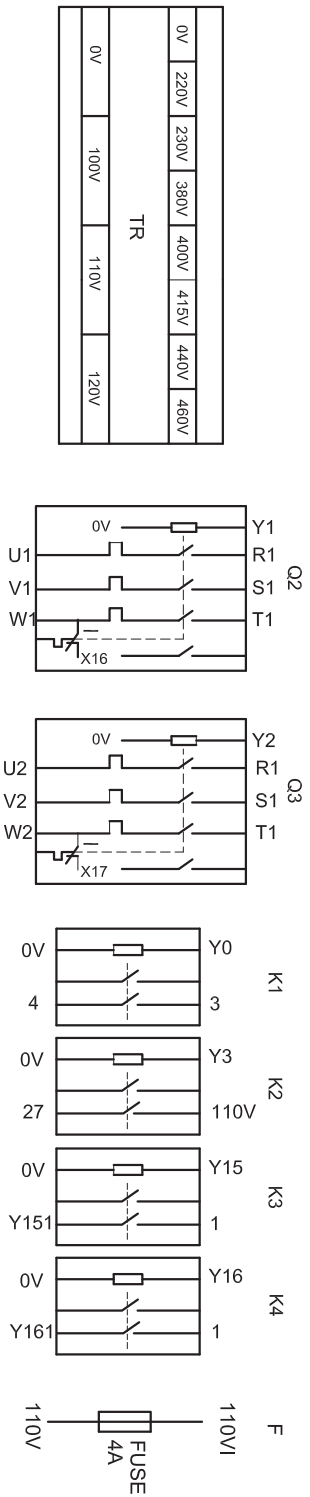
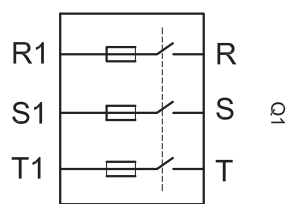

TB2

TB3

TB1

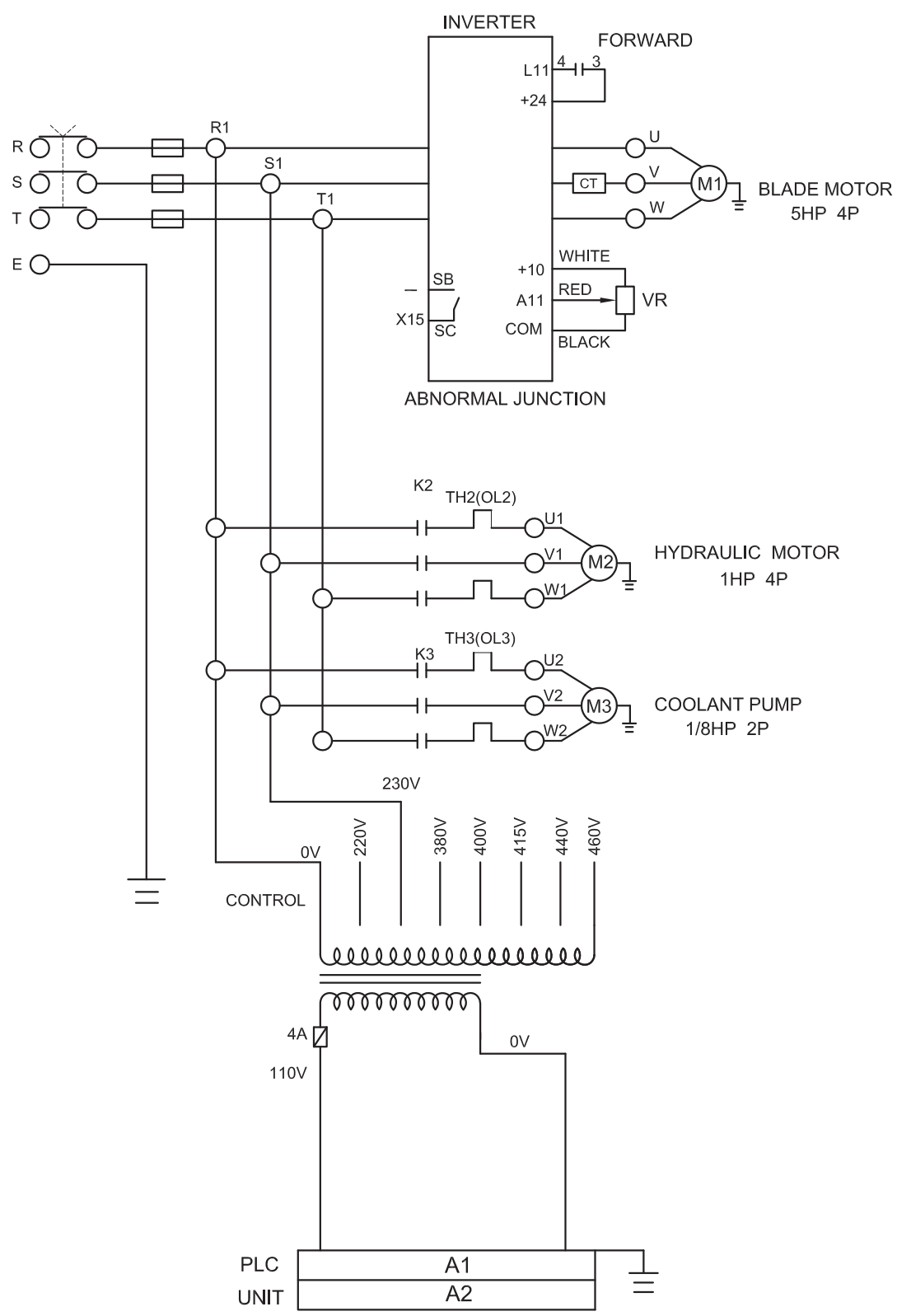

HEIGHT ENCODER

FEEDING ENCODER

A1 B1

A B + -

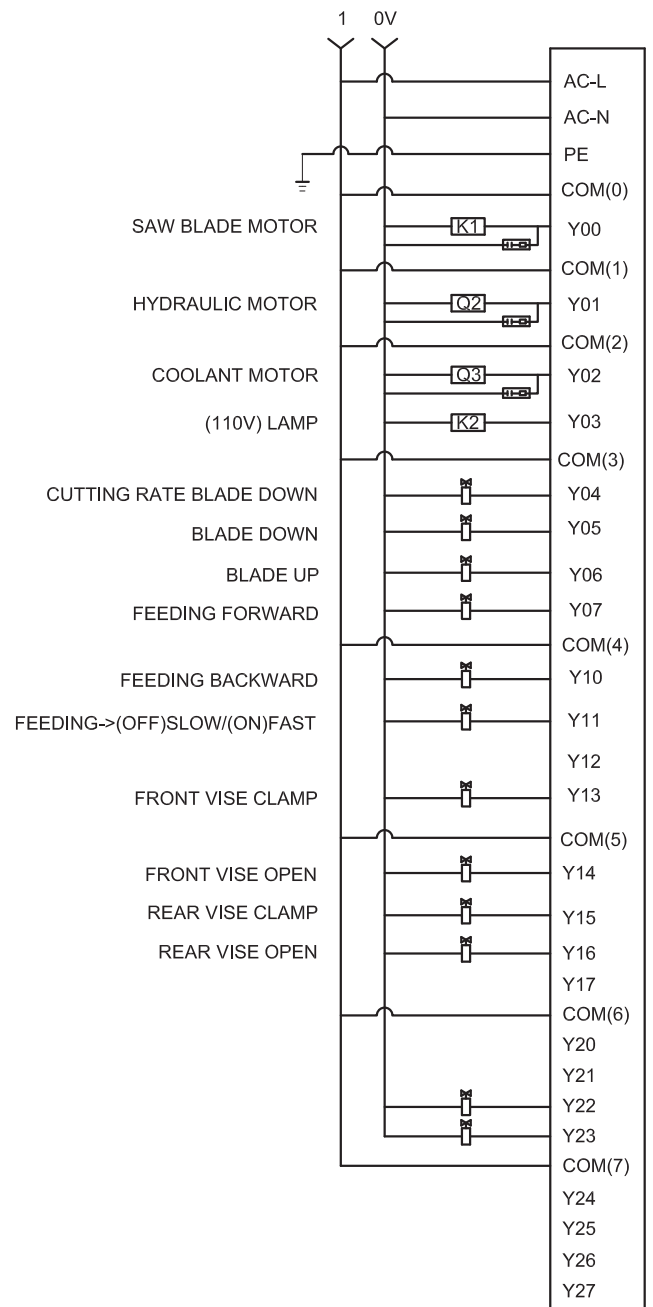
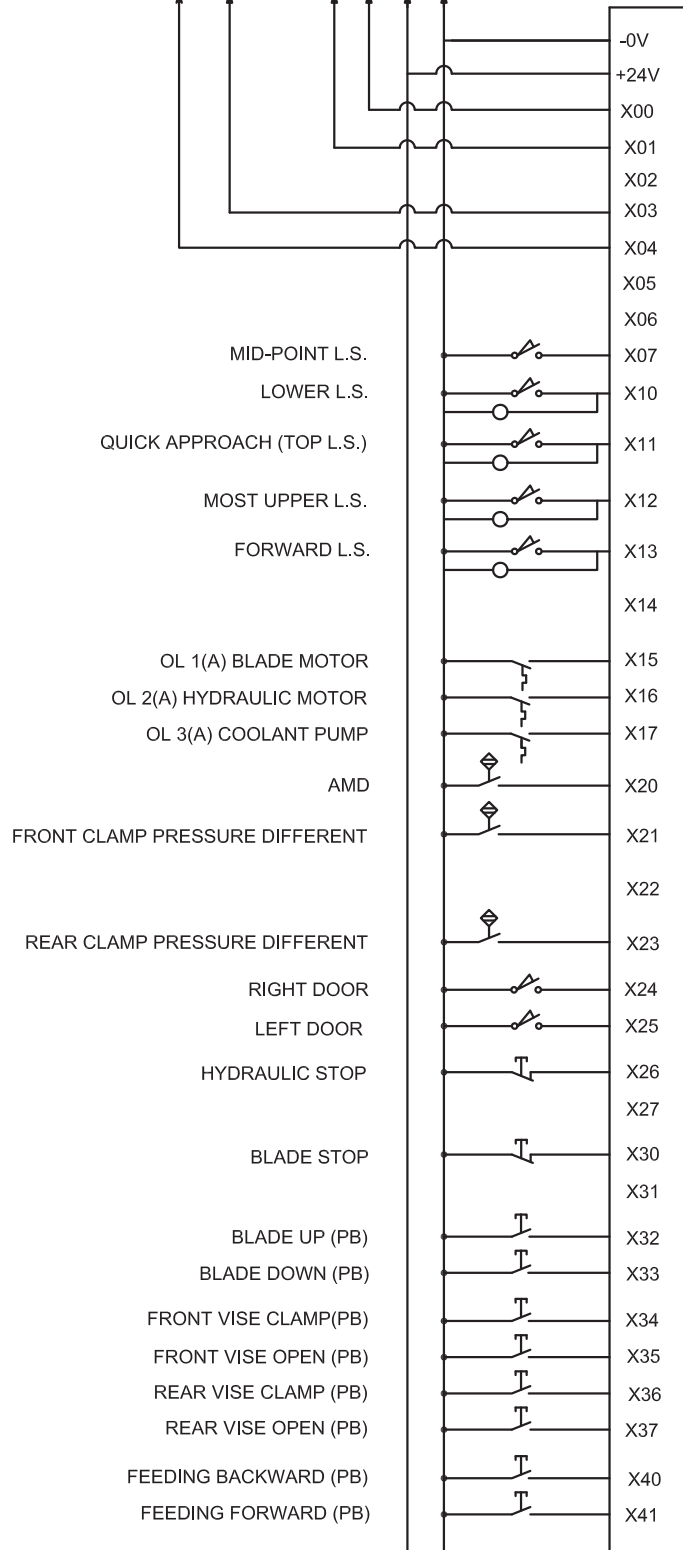

Section 6

HYDRAULIC SYSTEM

HYDRAULIC CIRCUIT DIAGRAM

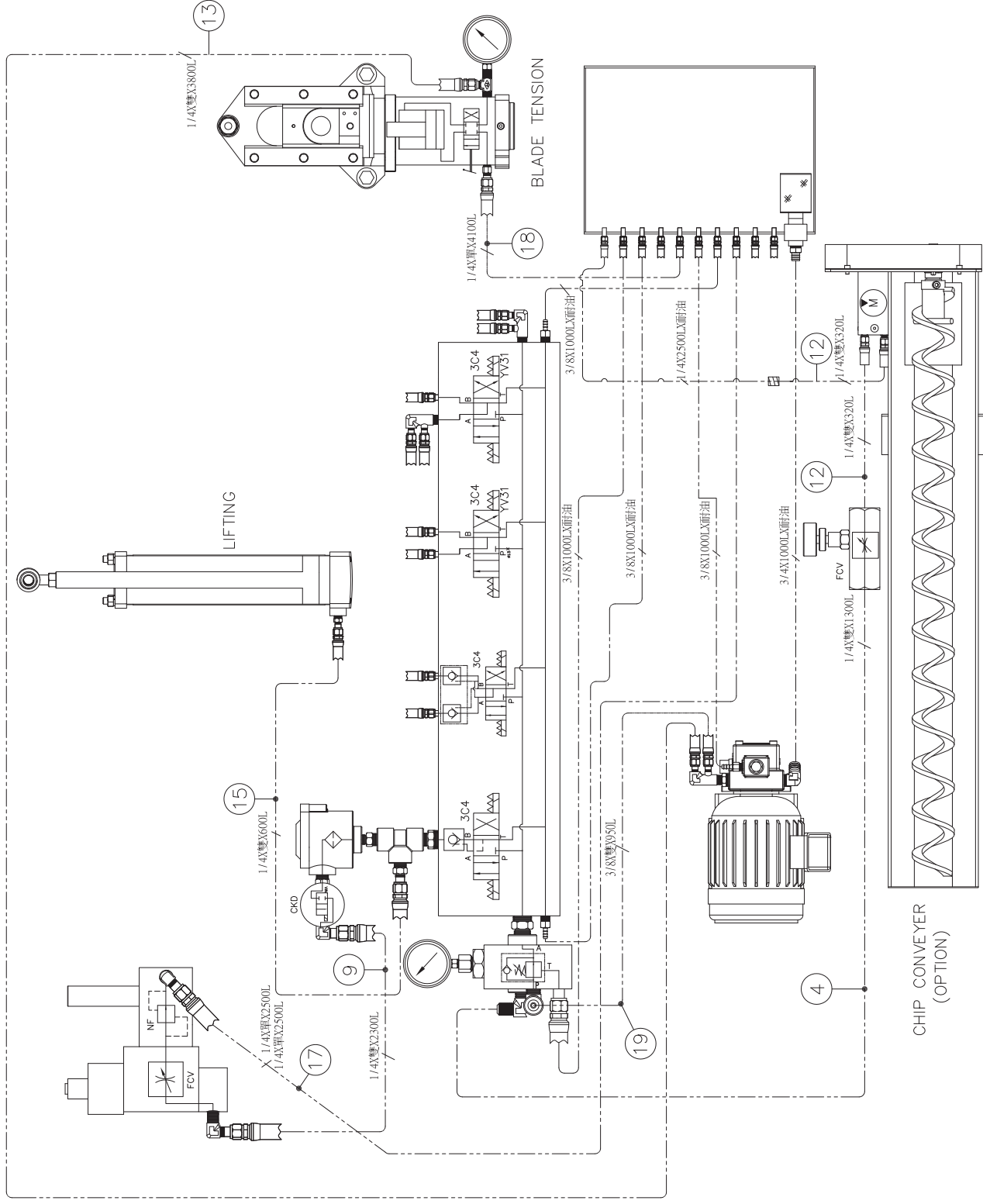

NOTE

DRAW	20140911	日編功
CHECK		
APPROVED		
DATE		NAME

COSEN	COSEN MECHATRONICS CO.,LTD.
TITLE	05G320-AM55 HYDRAULIC CIRCUIT
DRAWING NO. 05G320	HYDRADWG VERSION 1-0

COSEN

05C-G320 AM55

HYDRAULIC CIRCUIT

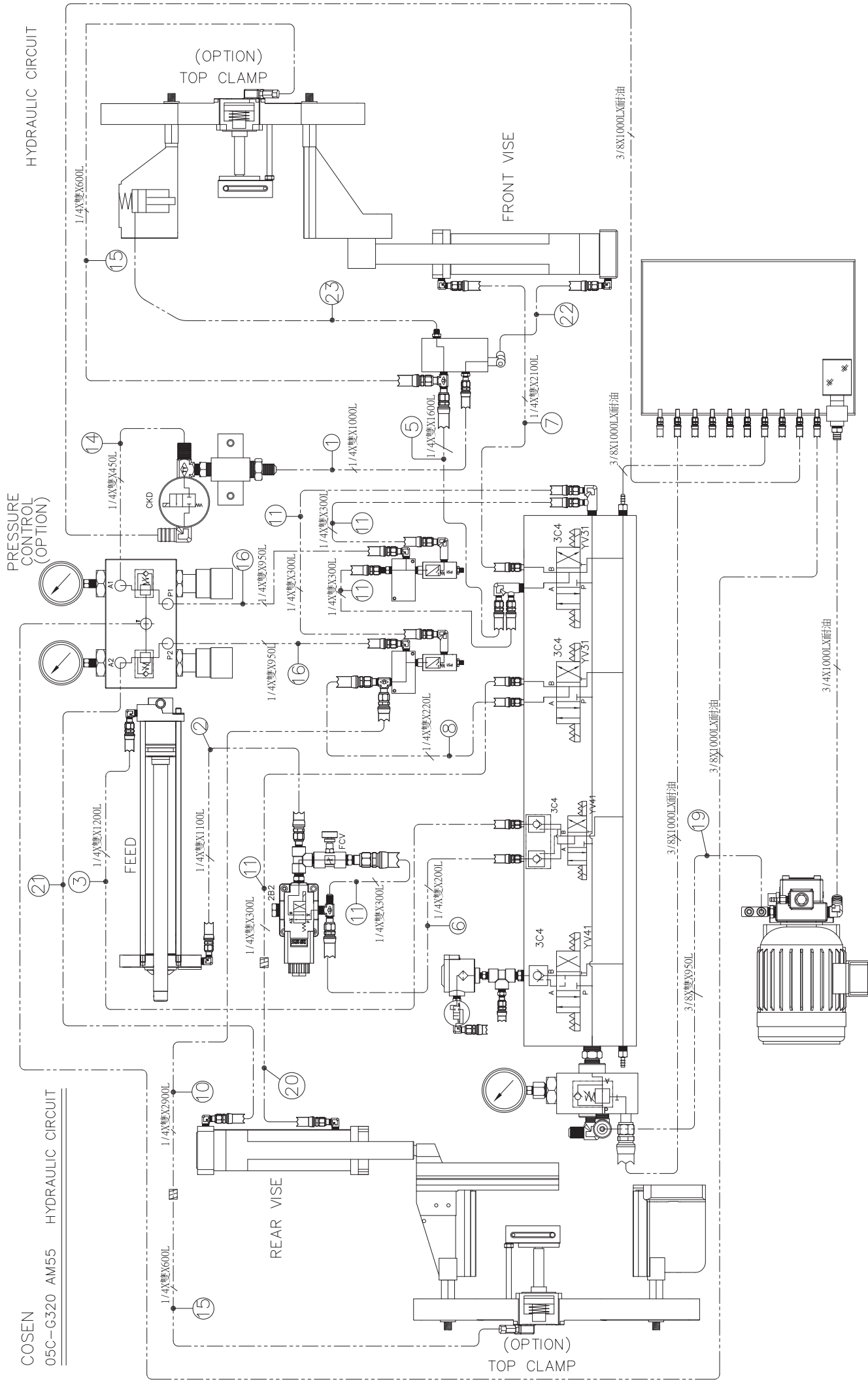

NOTE

管理印

20140911

DRAW CHECK

COSEN MECHATRONICS CO.,LTD.

05C320-AM55 HYDRAULIC CIRCUIT

DATE

APPROVED

VERSION

HYDRA.DWG

1-0

NAME

ITEM.	PART NO.	PART NAME	Specification
1	PHD-02D-1000*T	Hydraulic pipe	油壓管 1/4 xDouble xL1000
2	PHD-02D-1100*T	Hydraulic pipe	油壓管 1/4 xDouble xL1100
3	PHD-02D-1200*T	Hydraulic pipe	油壓管 1/4 xDouble xL1200
4	PHD-02D-1300*T	Hydraulic pipe	油壓管 1/4 xDouble xL1300
5	PHD-02D-1600*T	Hydraulic pipe	油壓管 1/4 xDouble xL1600
6	PHD-02D-200*T	Hydraulic pipe	油壓管 1/4 xDouble xL200
7	PHD-02D-2100*T	Hydraulic pipe	油壓管 1/4 xDouble xL2100
8	PHD-02D-220*T	Hydraulic pipe	油壓管 1/4 xDouble xL220
9	PHD-02D-2300*T	Hydraulic pipe	油壓管 1/4 xDouble xL2300
10	PHD-02D-2900*T	Hydraulic pipe	油壓管 1/4 xDouble xL2900
11	PHD-02D-300*T	Hydraulic pipe	油壓管 1/4 xDouble xL300
12	PHD-02D-320*T	Hydraulic pipe	油壓管 1/4 xDouble xL320
13	PHD-02D-3800*T	Hydraulic pipe	油壓管 1/4 xDouble xL3800
14	PHD-02D-450*T	Hydraulic pipe	油壓管 1/4 xDouble xL450
15	PHD-02D-600*T	Hydraulic pipe	油壓管 1/4 xDouble xL600
16	PHD-02D-950*T	Hydraulic pipe	油壓管 1/4 xDouble xL950
17	PHD-02S-2500*T	Hydraulic pipe	油壓管 1/4 xSingle xL2500
18	PHD-02S-4100*T	Hydraulic pipe	油壓管 1/4 xSingle xL4100
19	PHD-03D-950*T	Hydraulic pipe	油壓管 3/8 xDouble xL950
20	C320G-2865A-1	Front vise tube(1)	
21	C320G-2865A-2	Front vise tube(2)	
22	C320G-2861A	Feeding seat tube	
23	C320G-2813	Double retracting vise tube	

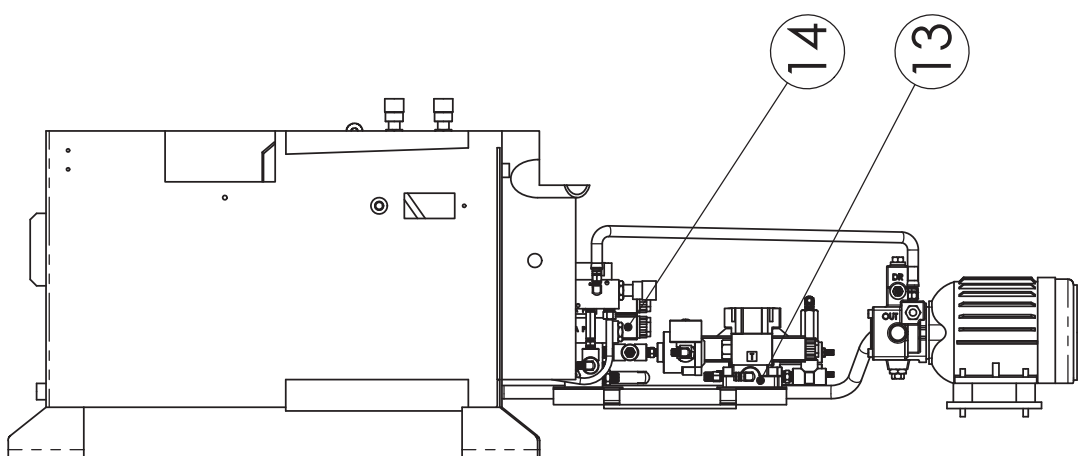
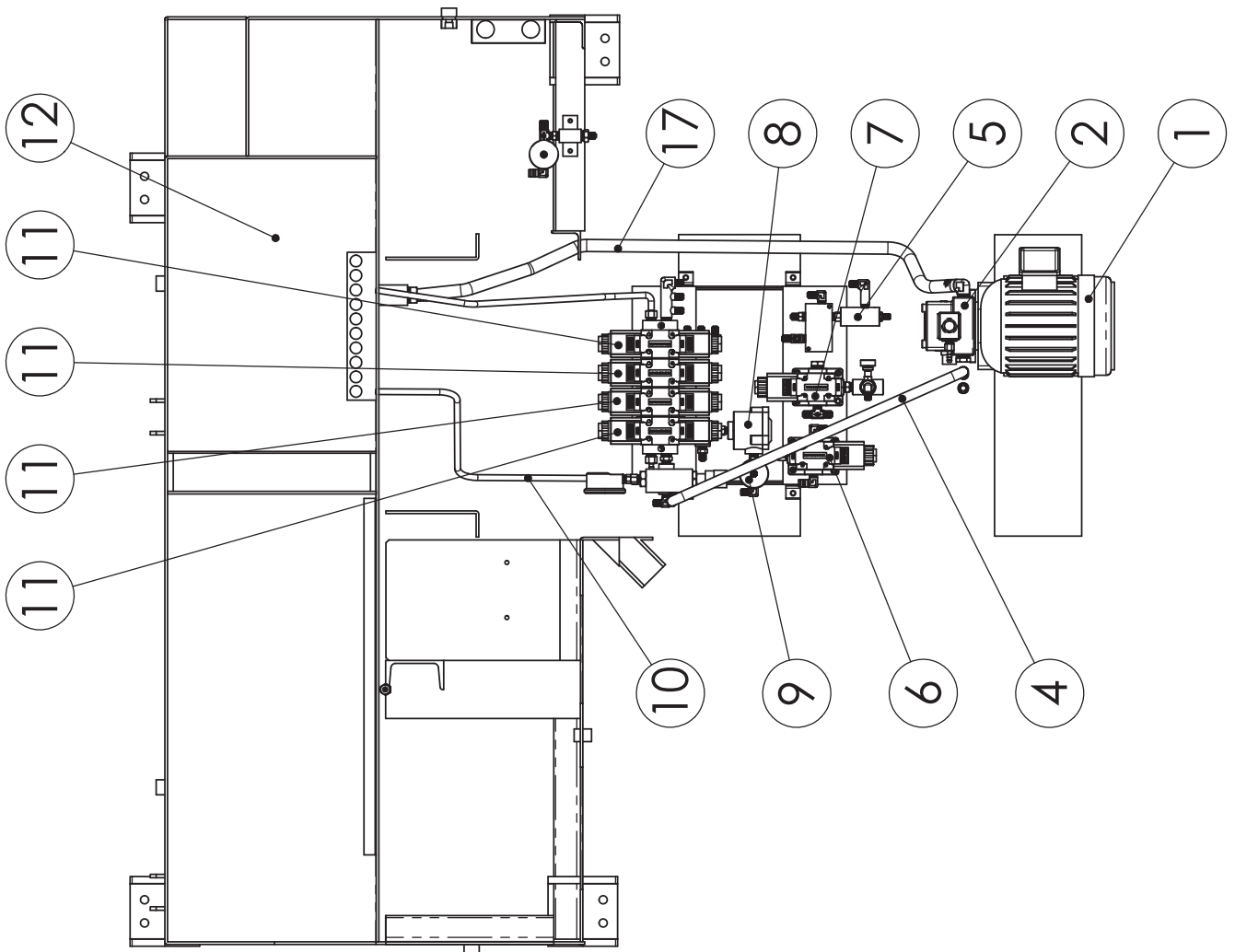
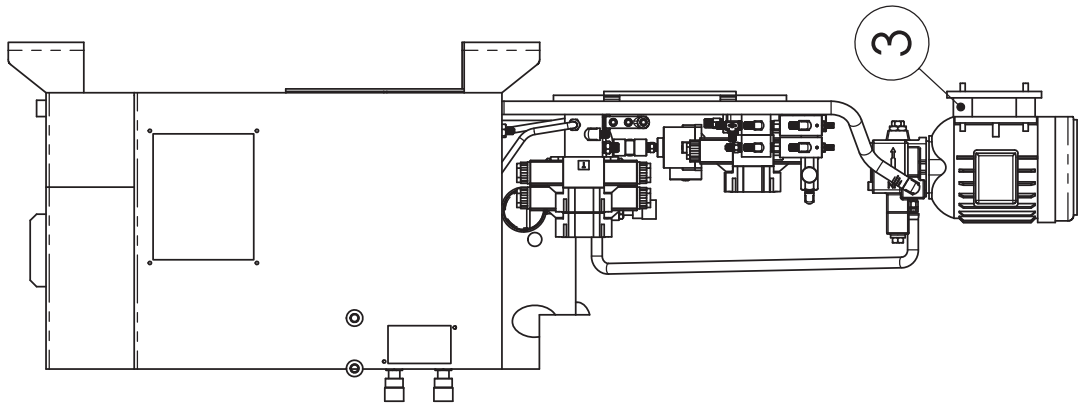

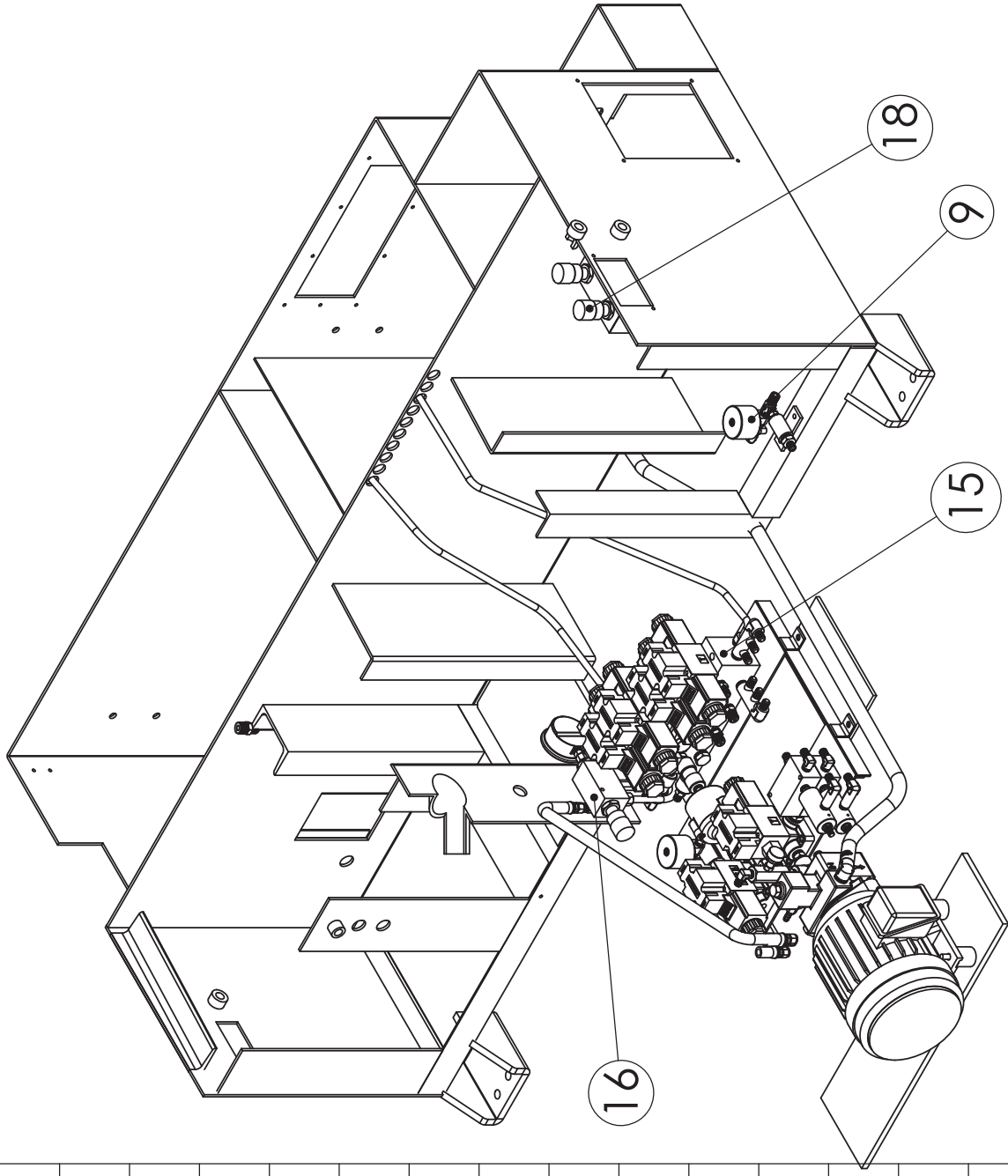

ITEM	PART NO.	PART CHINESE NAME	PART NAME
1		油壓馬達	Hydraulic motor
2	VCM-SF-20B-10	油泵	Vise manifold plate
3	PP-70700-1	防震墊	Rubber
4	3/8X雙X950L	系統油管	Pipe
5	NGG-33000	壓差閥	Manifold plate
6	PP-43503	2B2電磁閥	2B2 Solenoid valve
7	PP-43503	2B2電磁閥	2B2 Solenoid valve
8	AGB-707270	濾油器	Oil filter assembly
9	CKD	電磁閥	Solenoid valve
10	3/8X1000LX耐油管	系統回油管	Pipe
11	PP-43521	3C4電磁閥	3C4 Solenoid valve
12		油箱	Oil tank
13	SJM-4043-1	油路板	Manifold block
14	PP-43125	引導式止回閥	Guiding check valve
15	AHA-1001B	油路塊	Manifold block
16	PP-43127B	減壓閥	Pressure regulator
17	3/4X1000LX耐油管	入油管	Pipe
18	PP-43127A	減壓閥	Pressure regulator

Section 7

BANDSAW CUTTING: A PRACTICAL GUIDE

INTRODUCTION

SAW BLADE SELECTION

WISE LOADING

BladeBreak -In

SOLUTIONS TO SAWING PROBLEMS

INTRODUCTION

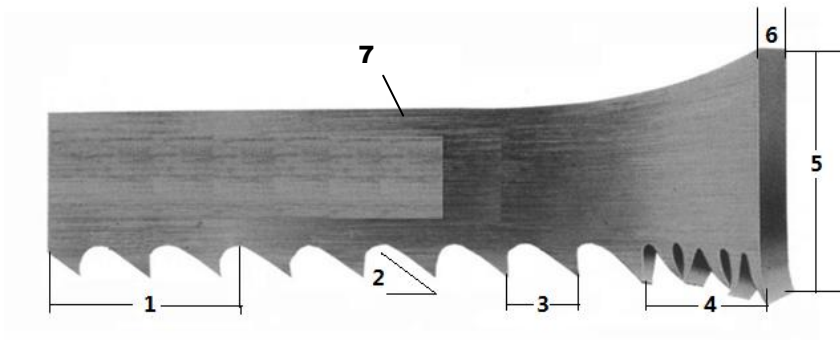

- 1. TPI:** The number of teeth per inch as measured from gullet to gullet.
- 2. Tooth Rake Angle:** The angle of the tooth face measured with respect to a line perpendicular to the cutting direction of the saw.
- 3. Tooth Pitch:** Tooth pitch refers to the number of teeth per inch (tpi). 1 inch equates to 25.4 mm.

A distinction is made between constant tooth pitches with a uniform tooth distance, 2 tpi for example, and variable tooth pitches with different tooth distances within one toothing interval.

Variable tooth pitches, for instance 2-3 tpi, can be characterized by two measures: 2 tpi stands for the maximum tooth distance and 3 tpi stands for the minimum tooth distance in the toothing interval.

Constant



Variable

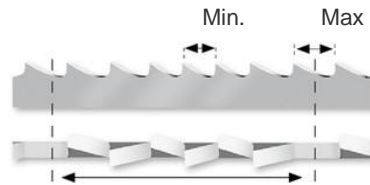

- 4. Set:** The bending of teeth to right or left to allow clearance of the back of the blade through the cut.
- 5. Width:** The nominal dimension of a saw blade as measured from the tip of the tooth to the back of the band.
- 6. Thickness:** The dimension from side to side on the blade.
- 7. Gullet:** The curved area at the base of the tooth. The tooth tip to the bottom of the gullet is the gullet depth.

SAW BLADE SELECTION

1. Band length

The dimensions of the band will depend on the band saw machine that has been installed.

Please refer to Section 2 – General Information

2. Band width

Band width: the wider the band saw blade, the more stability it will have.

3. Cutting edge material

The machinability of the material to be cut determines what cutting material you should choose.

4. Tooth pitch

The main factor here is the contact length of the blade in the workpiece.

If it is 4P, $25.4 \div 4 P = 6.35$ mm, that is, one tooth is 6.35 mm.

If it is 3P, $25.4 \div 3 P = 8.46$ mm If the number is small, it means that the tooth is large.

What is written as 3/4 is that it is a variable pitch of large (3) / small (4).

The saw blade must contact the cutting material at least two pitches. In the case of a thickness of 15 mm, 4P = OK, 3P = NG.

- The surface conditions will also affect the cutting rate. If there are places on the surface on the material which are hard, a slower blade speed will be required or blade damage may result.
- It will be slower to cut tubing than to cut solids, because the blade must enter the material twice, and because coolant will not follow the blade as well.
- Tough or abrasive materials are much harder to cut than their machinability rating would indicate.
- Tooth spacing is determined by the hardness of the material and its thickness in cross section.
- Tooth set prevents the blade from binding in the cut. It may be either a "regular set" (also called a "raker set") or a "wavy set".
- The regular or raker set is most common and consists of a pattern of one tooth to the left, one tooth to the right, and one which is straight, or unset. This type of set is generally used where the material to be cut is uniform in size and for contour cutting.
- Wavy set has groups of teeth set alternately to right and left, forming a wave-like pattern. This reduces the stress on each individual tooth, making it suitable for cutting thin material or a variety of materials where blade changing is impractical. Wavy set is often used where tooth breakage is a problem. This is shown in Fig. 7.2 as follows:

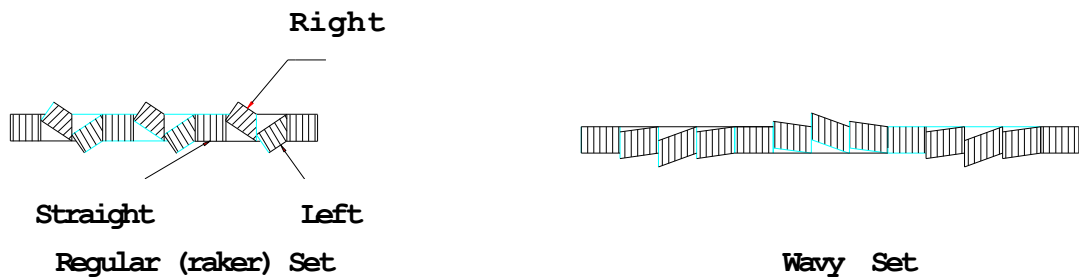

Fig. 7.2 The Saw Set

WISE LOADING

The position in which material is placed in the vise can have a significant impact on the cost per cut.

Often, loading smaller bundles can mean greater sawing efficiency.



When it comes to cutting odd-shaped material, such as angles, I-beams, channel, and tubing, the main point is to arrange the materials in such a way that the blade cuts through as uniform a width as possible throughout the entire distance of cut.

The following diagrams suggest some costeffective ways of loading and fixturing. Be sure, regardless of the arrangement selected, that the work can be firmly secured to avoid damage to the machine or injury to the operator.



BladeBreak -In

Completing a proper break-in on a new band saw blade will dramatically increase its life.

1. Select the proper band speed for the material to be cut.

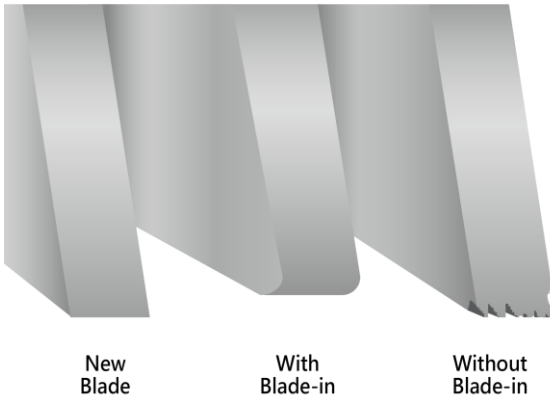

2. Reduce the feed force/rate to achieve a cutting rate 20% to 50% of normal (soft materials require a larger feed rate reduction than harder materials).

3.Begin the first cut at the reduced rate. Make sure the teeth are forming a chip. Small adjustments to the band speed may be made in the event of excessive noise/vibration. During the first cut, **increase feed rate/force** slightly once the blade fully enters the workpiece. With each following cut, **gradually increase feed rate/force** until normal cutting rate is reached.

MAINTENANCE & SERVICE

INTRODUCTION

BASIC MAINTENANCE

MAINTENANCE SCHEDULE

BEFORE BEGINNING A DAY'S WORK

AFTER ENDING A DAY'S WORK

EVERY MONTH

EVERY THREE MONTHS

EVERY SIX MONTHS

STORAGE CONDITIONS

TERMINATING THE USE OF MACHINE

OIL RECOMMENDATION FOR MAINTENANCE

INTRODUCTION

For the best performance and longer life of the band saw machine, a maintenance schedule is necessary. Some of the daily maintenance usually takes just a little time but will give remarkable results for the efficient and proper operation of cutting.

BASIC MAINTENANCE

It is always easy and takes just a little effort to do the basic maintenance. But it always turns out to be a very essential process to assure the long life and efficient operation of the machine. Most of the basic maintenance requires the operator to perform it regularly.

MAINTENANCE SCHEDULE

We suggest you do the maintenance on schedule.

Before beginning a day's work

1. Please check the hydraulic oil level. If oil level volume is below 1/2, please add oil as necessary.(Filling up to 2/3 level is better for system operation.)
2. Please check the cutting fluid level, adding fluid as necessary. If the fluid appears contaminated or deteriorated, drain and replace it.
3. Please check the saw blade to ensure that it is properly positioned on both the drive and idle wheels.
4. Please make sure that the saw blade is properly clamped by the left and right inserts.
5. Please check the wire brush for proper contact with the saw blade. Replace the wire brush if it is worn out.

After ending a day's work

Please remove saw chips and clean the machine with discharging the cutting fluid when work has been completed.



Do not discharge cutting fluid while the saw blade is operating because it will cause severe injury on operator's hand.



Be sure the saw blade is fully stop, it will be performed after working inspection.

Every 2 weeks

Please apply grease to the following points:

1. Idle wheel
2. Drive wheel
3. Blade tension device

Recommended Grease:

- Shell Alvania EP Grease 2
- Mobil Mobilplex 48

First 600hrs for new machine,then every 1200hrs

Replace the transmission oil after operating for first 600hrs for new machine,then every 1200hrs

Recommended gear oil

- Shell Omala oil HD220
- Mobil gear 630

Recommended hydraulic oil

- ShellTellus 32
- Mobil DTE Oil Light Hydraulic 28

Every six months

1. Clean the filter of the cutting fluid.
2. Replace the transmission oil for every half of a year (or 1200 hours).
Check the sight gauge to ascertain the transmission level.

Recommended TRANSMISSION OIL

- Omala oil HD220
- Mobil comp 632 600W Cylinder oil

3. Replace the hydraulic oil.

Recommended HYDRAULIC OIL

- Shell Tellus 27
- Mobil DTE OIL light Hydraulic28

STORAGE CONDITIONS

Generally, this machine will be stored on the following conditions in future:

- (1) Turn off the power.
- (2) Ambient temperature: 5°C ~ 40°C
- (3) Relative humidity: 30%~95% (without condensation)
- (4) Atmosphere: use a plastic canvas to cover machine to avoid excessive dust, acid fume, corrosive gases and salt.
- (5) Avoid exposing to direct sunlight or heat rays which can change the environmental temperature.
- (6) Avoid exposing to abnormal vibration.
- (7) Must be connected to earth.

TERMINATING THE USE OF THE MACHINE

Waste disposal:

When your machine can not work anymore, you should leak out the oil from machine body. Please storage the oil in safe place with bottom. Ask a environment specialist to handle the oil. It can avoid soil pollution. The oil list in machine:

- Hydraulic oil
- Cutting fluid
- Drive wheel gear oil

OIL RECOMMENDATION FOR MAINTENANCE

Item	Method	Revolution	Suggest oil
Dovetail guide	Keep grease covered. Antirust.	Daily	Shell R2
Roller bearing	Sweep clean and oil with lubricant.	Daily	SEA #10
Bed roller / surface	Sweep clean and oil with lubricant.	Daily	SEA #10
Nipples of bearing	Use grease gun, but not excess.	Monthly	Shell R2
Blade tension device	Use grease gun, but not excess.	Monthly	Shell Alvania EP Grease 2, Mobil Mobilplex 48
Reducer	Inspect once a week. Change oil of 600 hours of using. Change it every year.	Regularly	Omala oil HD220 Mobil Gear 630
Hydraulic system	Inspect half a year. Change oil every year.	Regularly	Shell Tellus 32 Mobil DTE oil Light Hydraulic 24
Bearing	Inserts	Oil with lubricant, but not excess.	Daily
	Band wheel	Oil with lubricant, but not excess.	Weekly
	Cylinder	Oil with lubricant, but not excess.	6 Monthly
	Wire brush	Oil with lubricant, but not excess.	6 Monthly



- 1. Turn off the stop circuit breaker switch before servicing the machine.**
- 2. Then post a sign to inform people that the machine is under maintenance.**
- 3. Drain all of the cutting fluid and oil off and carefully treat them to avoid pollution.**

TROUBLESHOOTING

INTRODUCTION

PRECAUTIONS

GENERAL TROUBLES & SOLUTIONS

MINOR TROUBLES & SOLUTIONS

MOTOR TROUBLES & SOLUTIONS

BLADE TROUBLES & SOLUTIONS

SAWING PROBLEMS & SOLUTIONS

RE-ADJUSTING THE ROLLER TABLE

INTRODUCTION

All the machines manufactured by us pass a 48 hours continuously running test before shipping out and we are responsible for the after sales service problems during the warranty period if the machines are used normally. However, there still exist the some unpredictable problems which may disable the machine from operating.

Generally speaking, the system troubles in this machine model can be classified into three types, namely GENERAL TROUBLES, MOTOR TROUBLES and BLADE TROUBLES. Although you may have other troubles which can not be recognized in advance, such as malfunctions due to the limited life-span of mechanical, electric or hydraulic parts of the machine.

We have accumulated enough experiences and technical data to handle all of the regular system troubles. Meanwhile, our engineering department had been continuously improving the machines to prevent all possible troubles.

It is hoped that you will give us your maintenance experience and ideas so that both sides can achieve the best performance.

PRECAUTIONS

When an abnormality occurs in the machine during operation, you can do it yourself safely. If you have to stop machine motion immediately for parts exchanging, you should do so according to the following procedures:

- Press HYDRAULIC MOTOR OFF button or EMERGENCY STOP button.
- Open the electrical enclosure door.
- Turn off breaker.



BEFORE ANY ADJUSTMENT OR MAINTENANCE OF THE MACHINE, PLEASE MAKE SURE TO TURN OFF THE MACHINE AND DISCONNECT THE POWER SUPPLY.

GENERAL TROUBLES AND SOLUTIONS



DISCONNECT POWER CORD TO MOTOR BEFORE ATTEMPTING ANY REPAIR OR INSPECTION.

TROUBLE	PROBABLE CAUSE	SUGGESTED REMEDY
Motor stalls	Excessive belt tension	Adjust belt tension so that belt does not slip on drive pulley while cutting (1/2" Min. deflection of belt under moderate pressure.)
	Excessive head pressure	Reduce head pressure. Refer to Operating Instructions "Adjusting Feed".
	Excessive blade speed	Refer to Operating Instructions "Speed Selection".
	Improper blade selection	Refer to Operating Instructions "Blade Selection".
Cannot make square cut	Dull blade	Replace blade.
	Guide rollers not adjusted properly	Refer to Adjustments.
	Rear vise jaw not adjusted properly	Set fixed vise jaw 90° to blade.
	Excessive head pressure	Reduce head pressure. Refer to operating instructions "Adjusting Feed."
Increased cutting time	Dull blade	Replace blade
	Insufficient head pressure	Increase head pressure. Refer to Operating Instructions "Adjusting Feed."
	Reduce blade speed	Refer to Operating Instructions "Speed Selection."
Will not cut	Motor running in wrong direction	Reverse rotation of motor. (Motor rotation C.C.W. pulley end.)
	Blade teeth pointing in wrong direction	Remove blade, turn blade inside out. Re-install blade. (Teeth must point in direction of travel.)
	Hardened material	Use special alloy blades. (Consult your industrial distributor for recommendation on type of blade required.)

MINOR TROUBLES & SOLUTIONS

TROUBLE	PROBABLE CAUSE	SUGGESTED REMEDY
Saw blade motor does not run even though blade drive button is pressed.	Overload relay activated	Reset
	Saw blade is not at forward limit position.	Press SAW FRAME FORWARD button

MOTOR TROUBLES & SOLUTIONS

TROUBLE	PROBABLE CAUSE	SUGGESTED REMEDY
Motor will not start	Magnetic switch open, or protector open.	Reset protector by pushing red button (inside electric box.)
	Low voltage	Check power line for proper voltage.
	Open circuit in motor or loose connections.	Inspect all lead terminations on motor for loose or open connections.
Motor will not start, fuse or circuit breakers "blow".	Short circuit in line, cord or plug.	Inspect line, cord and plug for damaged insulation and shorted wire.
	Short circuit in motor or loose connections	Inspect all lead terminations on motor for loose or shorted terminals or worn insulation on wires.
	Incorrect fuses or circuit breakers in power line.	Install correct fuses or circuit breakers.
Motor fail to develop full power. (Power output of motor decreases rapidly with decrease in voltage at motor terminals.)	Power line overloaded with lights, appliances and other motors.	Reduce the load on the power line.
	Undersize wires or circuit too long.	Increase wire sizes, or reduce length of wiring
	General overloading of power company's facilities.	Request a voltage check from the power company
Motor overheat	Motor overloaded.	Reduce load on motor
	Air circulation through the motor restricted.	Clean out motor to provide normal air circulation through motor.
Motor stalls (Resulting in blown fuses or tripped circuit breakers)	Short circuit in motor or loose connections.	Inspect terminals in motor for loose or shorted terminals or worn insulation on lead wires.
	Low voltage	Correct the low line voltage conditions.
	Incorrect fuses or circuit breakers in power line.	Install correct fuses circuit breakers.
	Motor overloaded	Reduce motor load.
Frequent opening of fuses or circuit breakers.	Motor overloaded	Reduce motor load
	Incorrect fuses or circuit breakers.	Install correct fuses or circuit breakers.

BLADE TROUBLES AND SOLUTIONS



DISCONNECT POWER CORD TO MOTOR BEFORE ATTEMPTING ANY REPAIR OR INSPECTION.

TROUBLE	PROBABLE CAUSE	SUGGESTED REMEDY
Teeth strippage	Too few teeth per inch	Use finer tooth blade
	Loading of gullets	Use coarse tooth blade or cutting lubricant.
	Excessive feed	Decrease feed
	Work not secured in vise	Clamp material securely
Blade breakage	Teeth too coarse	Use a finer tooth blade
	Misalignment of guides	Adjust saw guides
	Dry cutting	Use cutting lubricant
	Excessive speed	Lower speed. See Operating Instructions "Speed selection."
	Excessive speed	Reduce feed pressure. Refer to Operating Instructions "Adjusting Feed."
	Excessive tension	Tension blade to prevent slippage on drive wheel while cutting.
Blade line Run-out or Run-in	Wheels out of line	Adjust wheels
	Guides out of line	For a straight and true cut, realign guides, check bearings for wear.
	Excessive pressure	Conservative pressure assures long blade life and clean straight cuts.
	Support of blade insufficient	Move saw guides as close to work as possible.
	Material not properly secured in vise	Clamp material in vise, level and securely.
Blade twisting	Blade tension improper	Loosen or tighten tension on blade.
	Blade not in line with guide bearings	Check bearings for wear and alignment.
	Excessive blade pressure	Decrease pressure and blade tension
Premature tooth wear	Blade binding in cut	Decrease feed pressure
	Dry cutting	Use lubricant on all materials, except cast iron
	Blade too coarse	Use finer tooth blade
	Not enough feed	Increase feed so that blade does not ride in cut
	Excessive speed	Decrease speed

SAWING PROBLEMS AND SOLUTIONS

Other than this manual, the manufacturer also provides some related technical documents listed as follows:

Sawing Problems and Solutions

					Vibration during cutting	Failure to cut	Short life of saw blade	Curved cutting	Broken blade		
✓	✓	✓	✓	✓						Use of blade with incorrect pitch	Use blade with correct pitch suited to workpiece width
✓	✓	✓	✓	✓						Failure to break-in saw blade	Perform break-in operation
✓	✓	✓								Excessive saw blade speed	Reduce speed
			✓	✓						Insufficient saw blade speed	Increase speed
✓		✓	✓	✓						Excessive saw head descending speed	Reduce speed
✓		✓	✓							Insufficient saw head descending speed	Increase speed
		✓	✓							Insufficient saw blade tension	Increase tension
✓		✓	✓	✓						Wire brush improperly positioned	Relocate
✓		✓	✓							Blade improperly clamped by insert	Check and correct
✓	✓	✓	✓	✓						Improperly clamped workpiece	Check and correct
	✓	✓	✓							Excessively hard material surface	Soften material surface
		✓	✓	✓						Excessive cutting rate	Reduce cutting rate
	✓	✓								Non-annealed workpiece	Replace with suitable workpiece
✓		✓	✓	✓						Insufficient or lean cutting fluid	Add fluid or replace
✓		✓	✓	✓						Vibration near machine	Relocate machine
		✓	✓							Non-water soluble cutting fluid used	Replace
✓		✓	✓							Air in cylinder	Bleed air
✓		✓		✓						Broken back-up roller	Replace
✓	✓	✓	✓	✓						Use of non-specified saw blade	Replace
✓	✓	✓	✓	✓						Fluctuation of line voltage	Stabilize
✓		✓	✓							Adjustable blade guide too far from workpiece	Bring blade guide close to workpiece
✓		✓	✓	✓						Loose blade guide	Tighten
		✓		✓						Blue or purple saw chips	Reduce cutting rate
✓		✓		✓						Accumulation of chips at inserts	Clean
	✓									Reverse positioning of blade on machine	Reinstall
✓		✓	✓							Workpieces are not bundled properly	Re-bundle
✓		✓		✓						Back edge of blade touching wheel flange	Adjust wheel to obtain clearance
✓	✓	✓								Workpiece of insufficient diameter	Use other machine, suited for diameter of workpiece
	✓	✓	✓							Saw blade teeth worn	Replace

SOLUTIONS TO SAWING PROBLEMS

Table Of Contents

#1. Heavy Even Wear On Tips and Corners Of Teeth	#11. Uneven Wear Or Scoring On The Sides Of Band
#2. Wear On Both Sides Of Teeth	#12. Heavy Wear And/Or Swagging On Back Edge
#3. Wear On One Side Of Teeth	#13. Butt Weld Breakage
#4. Chipped Or Broken Teeth	#14. Heavy Wear In Only The Smallest Gullets
#5. Body Breakage Or Cracks From Back Edge	#15. Body Breaking – Fracture Traveling In An Angular Direction
#6. Tooth Strippage	#16. Body Breakage Or Cracks From Gullets
#7. Chips Welded To Tooth Tips	#17. Band is Twisted Into A Figure "8" Configuration
#8. Gullets Loading Up With Material	#18. Used Band Is "Long" On The Tooth Edge
#9. Discolored Tips Of Teeth Due To Excessive Frictional Heat	#19. Used Band Is "Short" On The Tooth Edge
#10. Heavy Wear On Both Sides Of Band	#20. Broken Band Shows A Twist In Band Length.

#1. Heavy Even Wear On Tips and Corners Of Teeth

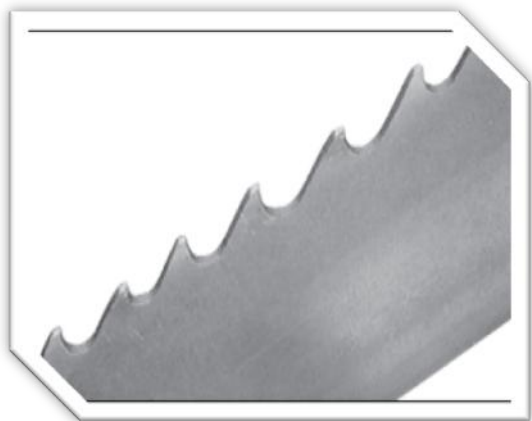

Probable Cause :

- A.** Improper break-in procedure.
- B.** Excessive band speed for the type of material being cut. This generates a high tooth tip temperature resulting in accelerated tooth wear.
- C.** Low feed rate causes teeth to rub instead of penetrate. This is most common on work hardened materials such as stainless and toolsteels.
- D.** Hard materials being cut such as "Flame Cut Edge" or abrasive materials such as " Fiber Reinforced Composites".
- E.** Insufficient sawing fluid due to inadequate supply, improper ratio, and/or improper application

#2. Wear On Both Sides Of Teeth

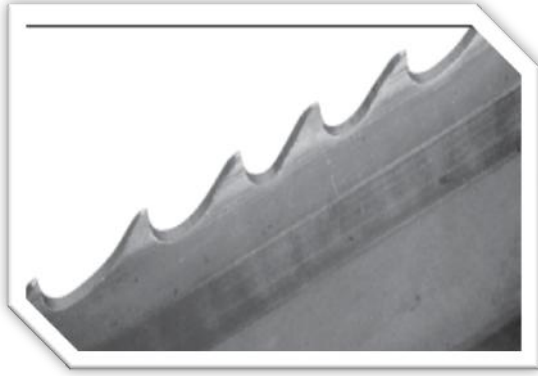

Probable Cause :

- A. Broken, worn or missing back-up guides allowing teeth to contact side guides.
- B. Improper side guides for band width.
- C. Backing the band out of an incomplete cut.

#3. Wear On One Side Of Teeth

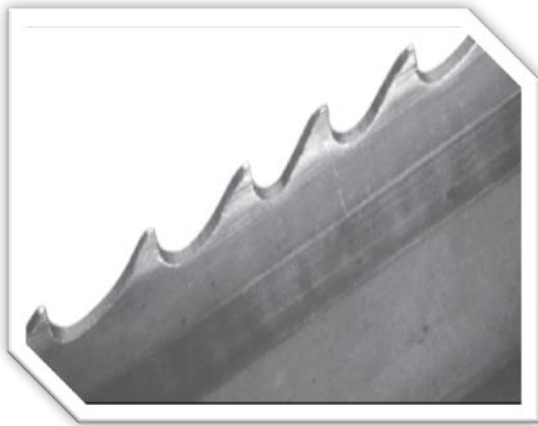

Probable Cause :

- A. Worn wheel flange, allowing side of teeth to contact wheel surface or improper tracking on flangeless wheel.
- B. Loose or improperly positioned side guides.
- C. Blade not perpendicular to cut.
- D. Blade rubbing against cut surface on return stroke of machine head.
- E. The teeth rubbing against a part of machine such as chip brush assembly, guards, etc.

#4. Chipped Or Broken Teeth

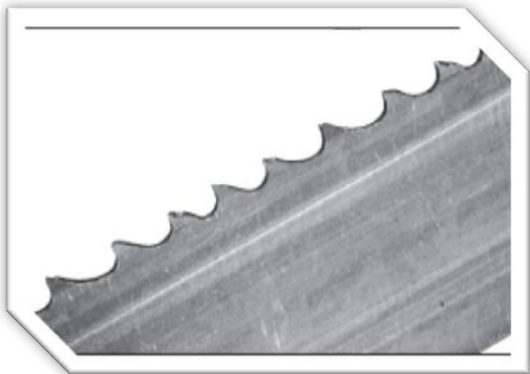

Probable Cause :

- A. Improper break-in procedure.
- B. Improper blade selection for application.
- C. Handling damage due to improper opening of folded band.
- D. Improper positioning or clamping of material.
- E. Excessive feeding rate or feed pressure.
- F. Hitting hard spots or hard scale in material

#5. Body Breakage Or Cracks From Back Edge

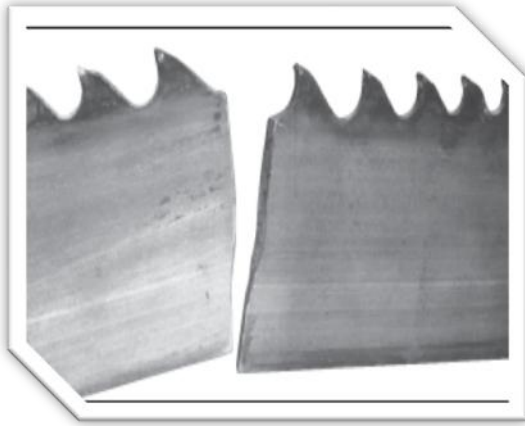

Probable Cause :

- A. Excessive back-up guide "preload" will cause back edge to work harden which results in cracking.
- B. Excessive feed rate.
- C. Improper band tracking – back edge rubbing heavy on wheel flange.
- D. Worn or defective back-up guides.
- E. Improper band tension.
- F. Notches in back edge from handling damage

#6. Tooth Strippage



Probable Cause :

- A. Improper or lack of break-in procedure.
- B. Worn, missing or improperly positioned chip brush.
- C. Excessive feeding rate or feed pressure.
- D. Movement or vibration of material being cut.
- E. Improper tooth pitch for cross sectional size of material being cut.
- F. Improper positioning of material being cut.
- G. Insufficient sawing fluid due to inadequate supply, improper ratio and/or improper application.
- H. Hard spots in material being cut.
- I. Band speed too slow for grade of material being cut.

#7. Chips Welded To Tooth Tips

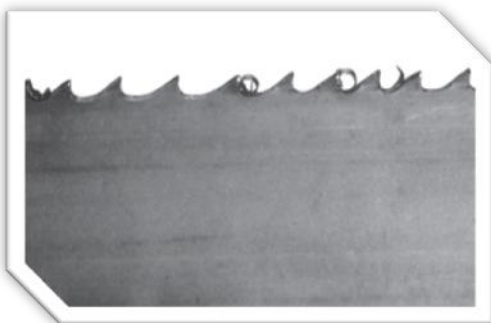

Probable Cause :

- A. Insufficient sawing fluid due to inadequate supply, improper ratio and/or improper application.
- B. Worn, missing or improperly positioned chip brush.
- C. Improper band speed.
- D. Improper feeding rate.

#8. Gullets Loading Up With Material

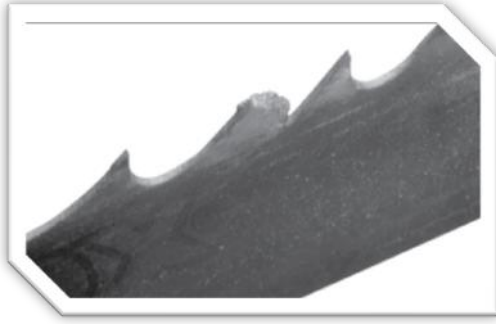

Probable Cause :

- A. Too fine of a tooth pitch – insufficient gullet capacity.
- B. Excessive feeding rate producing too large of a chip.
- C. Worn, missing or improperly positioned chip brush.
- D. Insufficient sawing fluid due to inadequate supply, improper ratio and/or improper application.

#9. Discolored Tips Of Teeth Due To Excessive Frictional Heat

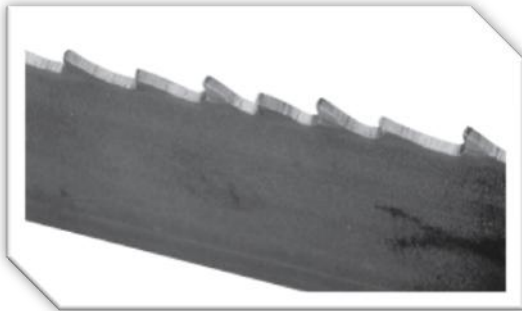

Probable Cause :

- A. Insufficient sawing fluid due to inadequate supply, improper ratio and/or improper application.
- B. Excessive band speed.
- C. Improper feeding rate.
- D. Band installed backwards.

10. Heavy Wear On Both Sides Of Band

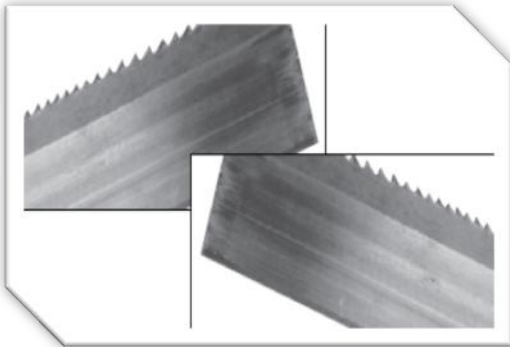

Probable Cause :

- A. Chipped or broken side guides.
- B. Side guide adjustment may be too tight.
- C. Insufficient flow of sawing fluid through the side guides.
- D. Insufficient sawing fluid due to inadequate supply, improper ratio and/or improper application.

#11. Uneven Wear Or Scoring On The Sides Of Band

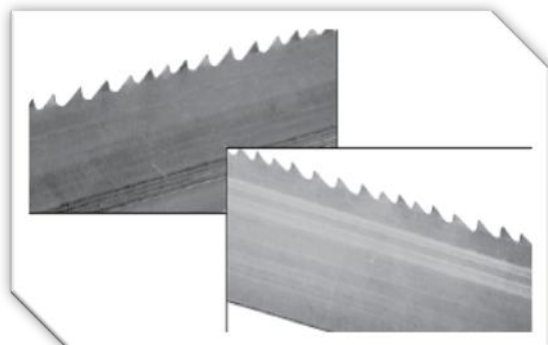

Probable Cause :

- A. Loose side guides.
- B. Chipped, worn or defective side guides.
- C. Band is rubbing on part of the machine.
- D. Guide arms spread to maximum capacity.
- E. Accumulation of chips in side guides.

#12. Heavy Wear And/Or Swagging On Back Edge



Probable Cause :

- A. Excessive feed rate.
- B. Excessive back-up guide "preload".
- C. Improper band tracking – back edge rubbing heavy on wheel flange.
- D. Worn or defective back-up guides.

#13. Butt Weld Breakage



Probable Cause :

- A. Any of the factors that cause body breaks can also cause butt weld breaks.
- (See Observations #5, #15 and #16)**

#14. Heavy Wear In Only The Smallest Gullets



Probable Cause :

- A. Excessive feeding rate.
- B. Too slow of band speed.
- C. Using too fine of a tooth pitch for the size of material being cut.

#15. Body Breaking – Fracture Traveling In An Angular Direction



Probable Cause :

- A. An excessive twist type of stress existed.
- B. Guide arms spread to capacity causing excessive twist from band wheel to guides.
- C. Guide arms spread too wide while cutting small cross sections.
- D. Excessive back-up guide "preload".

#16. Body Breakage Or Cracks From Gullets

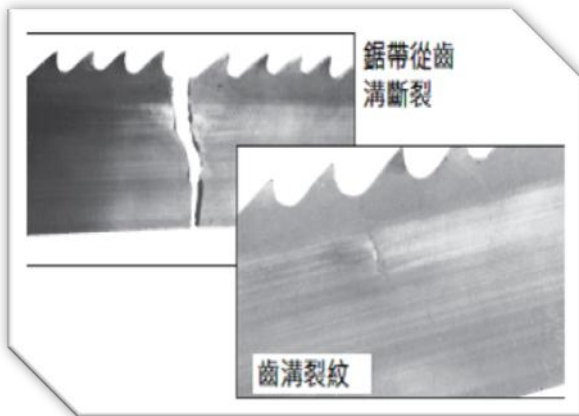

Probable Cause :

- A. Excessive back-up guide "preload".
- B. Improper band tension.
- C. Guide arms spread to maximum capacity.
- D. Improper beam bar alignment.
- E. Side guide adjustment is too tight.
- F. Excessively worn teeth.

#17. Band is Twisted Into A Figure "8" Configuration

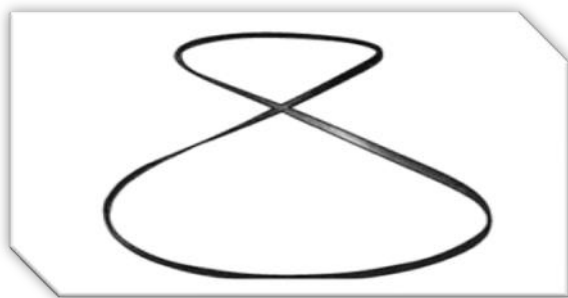

Probable Cause :

- A. Excessive band tension.
- B. Any of the band conditions which cause the band to be long (#18) or short (#19) on tooth edge.
- C. Cutting a tight radius.

#18. Used Band Is "Long" On The Tooth Edge



Probable Cause :

- A. Side guides are too tight – rubbing near gullets.
- B. Excessive "preload" – band riding heavily against back-up guides.
- C. Worn band wheels causing uneven tension.
- D. Excessive feeding rate.
- E. Guide arms are spread to maximum capacity.
- F. Improper band tracking – back edge rubbing heavy on wheel flange.

#19. Used Band Is "Short" On The Tooth Edge



Probable Cause :

- A. Side guides are too tight – rubbing near back edge.
- B. Worn band wheels causing uneven tension.
- C. Guide arms are spread too far apart.
- D. Excessive feeding rate.

#20. Broken Band Shows A Twist In Band Length

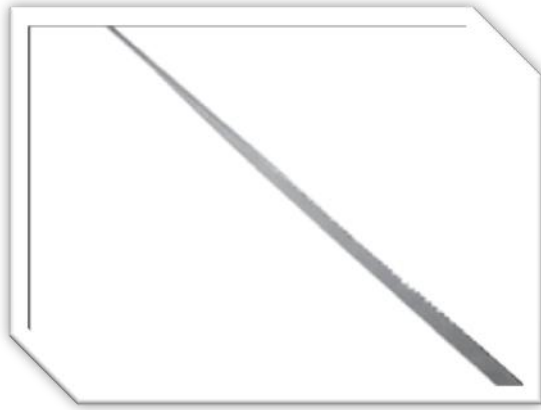

Probable Cause :

- A. Excessive band tension
- B. Any of the band conditions which cause the band to be long (#18) or short (#19) on tooth edge.
- C. Cutting a tight radius.

RE-ADJUSTING THE ROLLER TABLE

If the feeding table suffers the huge stroke and the alignment is effected, follow the below procedure to adjust.

TOOL, measuring

Measurement, Horizontal balance

Procedure

1. Screw or loosen the adjusting bolt to attain the horizontal balance (leveling) between the roller table and the machine frame.
2. Ensure that the machine frame is not struck by the loaded material on the feeding table.
3. Check the leveling by the measuring tool.
4. After finished the adjusting, fix the roller table.



If the feeding table and the machine frame are not positioned under the horizontal balance, the loaded material may be going up gradually and affect the cutting effect.

PARTS

SPARE PARTS RECOMMENDATIONS

PART LIST

SPARE PARTS RECOMMENDATIONS

The following table lists the common spare parts we suggest you purchase in advance:

Part Name	Part Name
Saw blade	Coolant tank filter
Wire brush	Steel plates
Carbide inserts	Rollers
Bearings	Belt
Hydraulic tank leak-proof gasket	Duster seal
Rubber washer	Snap ring
Oil seal	O-ring

高度譯碼器組

Height encoder assembly
エンコーダアセンブリ

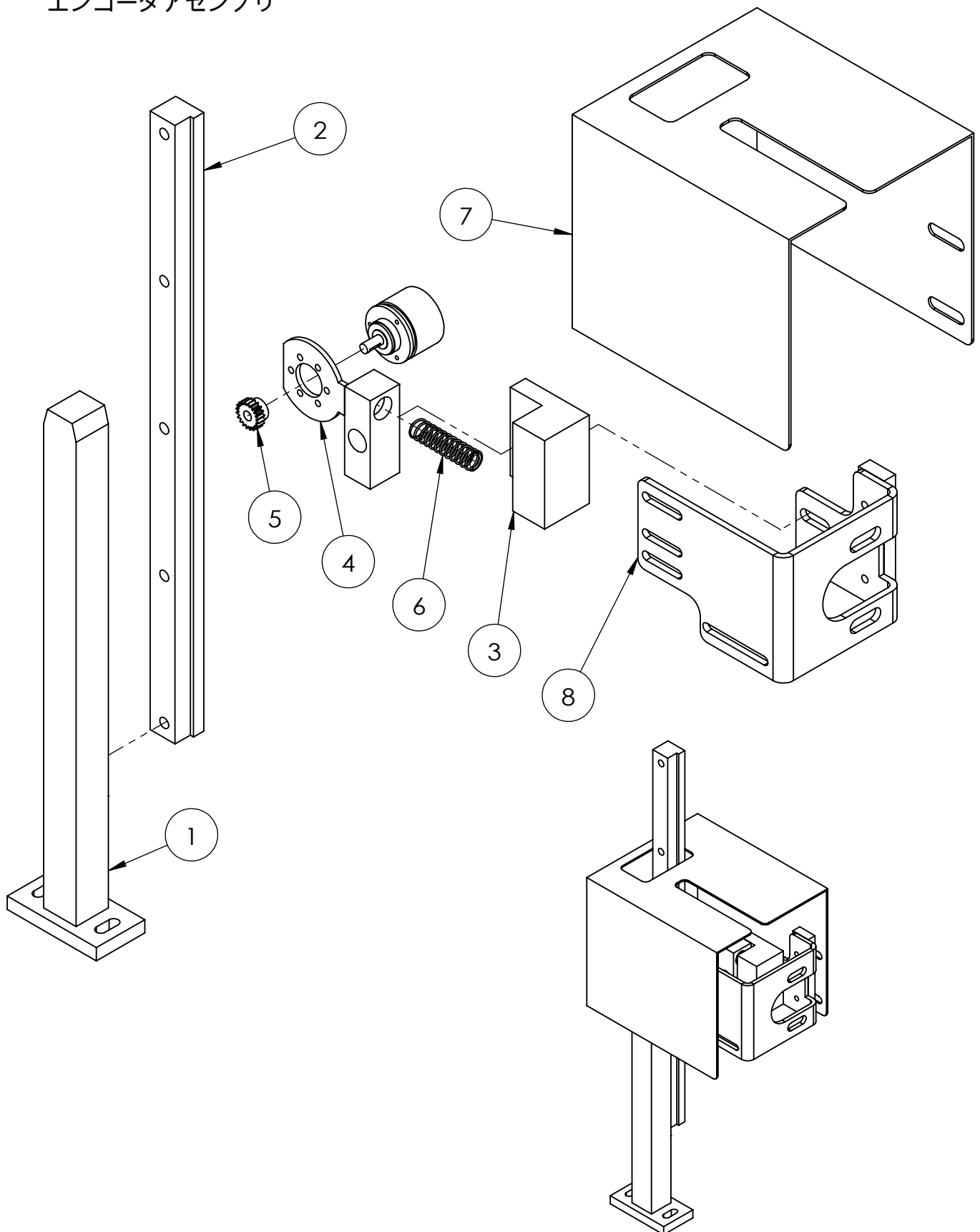

高度譯碼器 Height encoder assembly エンコーダアセンブリ						
ITEM	PART NO.	PART NAME	PART NAME IN CHINESE	PART NAME IN JAPAN	PART SPEC.	QTY
1	C320G-1116	Middle limit switch sliding bar	中限滑桿	ミドルリミットスイッチ スライドバー		1
2	C360L-2109A	Tooth bar	定寸齒條	インチラック		1
3	C320G-2103	encoder movable seat	譯碼器活動座	エンコーダ可動部品		1
4	C320G-70536	Encoder fixed seat	譯碼器固定座	エンコーダ固定部品		1
5	C560L-2105	Gear	定寸齒輪	ギア		1
6	M3L-9-10	Spring	微動彈簧	スプリング (バネ)		1
7	C320G-2104	Encoder cover	譯碼器護蓋	エンコーダカバー		1
8	C320G-1117A	Limit switch holder	限動開關固定座	リミットスイッチ ホルダー		1

護欄組

Safety Fence Assembly
セーフティフェンス

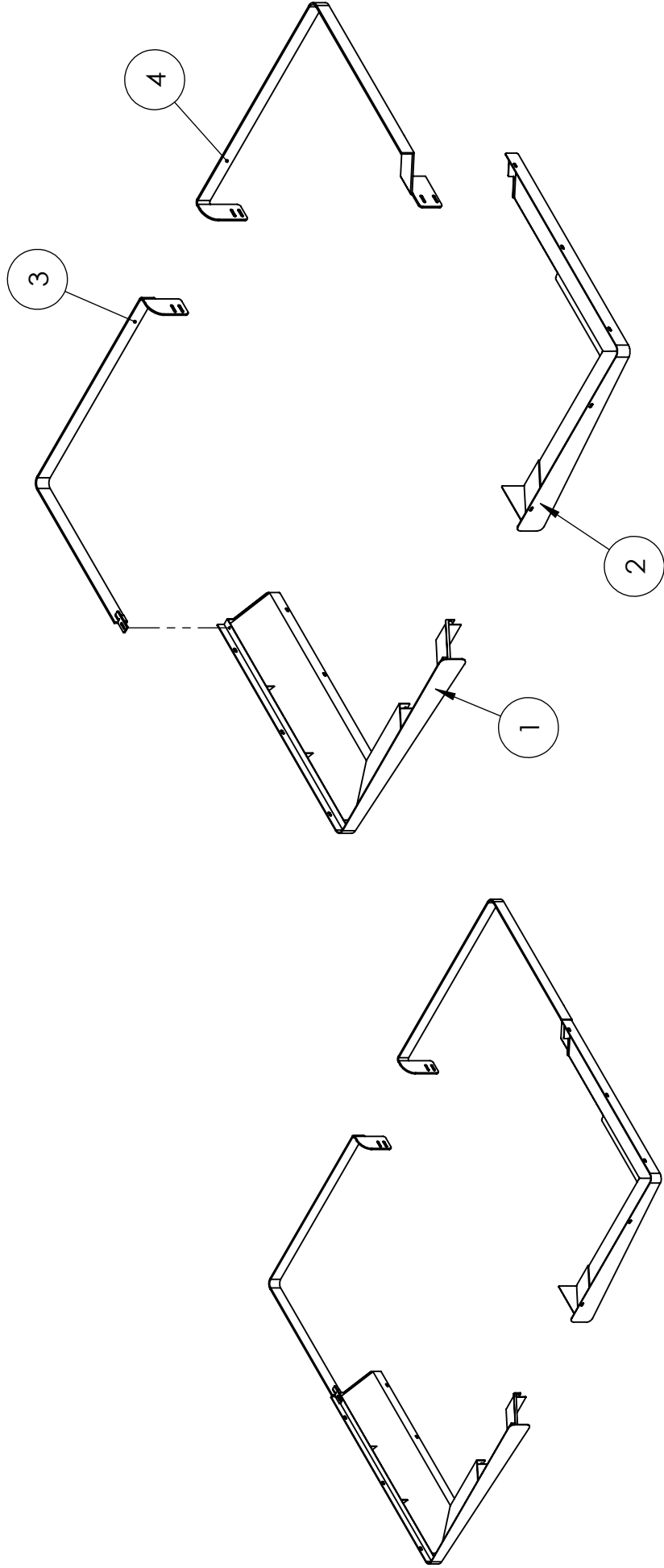



G320-AM55

20170321

護欄組 Safety Fence Assembly

ITEM	PART NO.	PART NAME	PART NAME IN CHINESE	PART SPEC.	QTY
1	C320G-1023C	Left splash shield	左防濺板		1
2	C320G-1025C	Right splash shield	右防濺板		1
3	C320G-1031A	Left safety fence	左扁鐵護欄		1
4	C320G-1033A	Right safety fence	右扁鐵護欄		1

馬達組

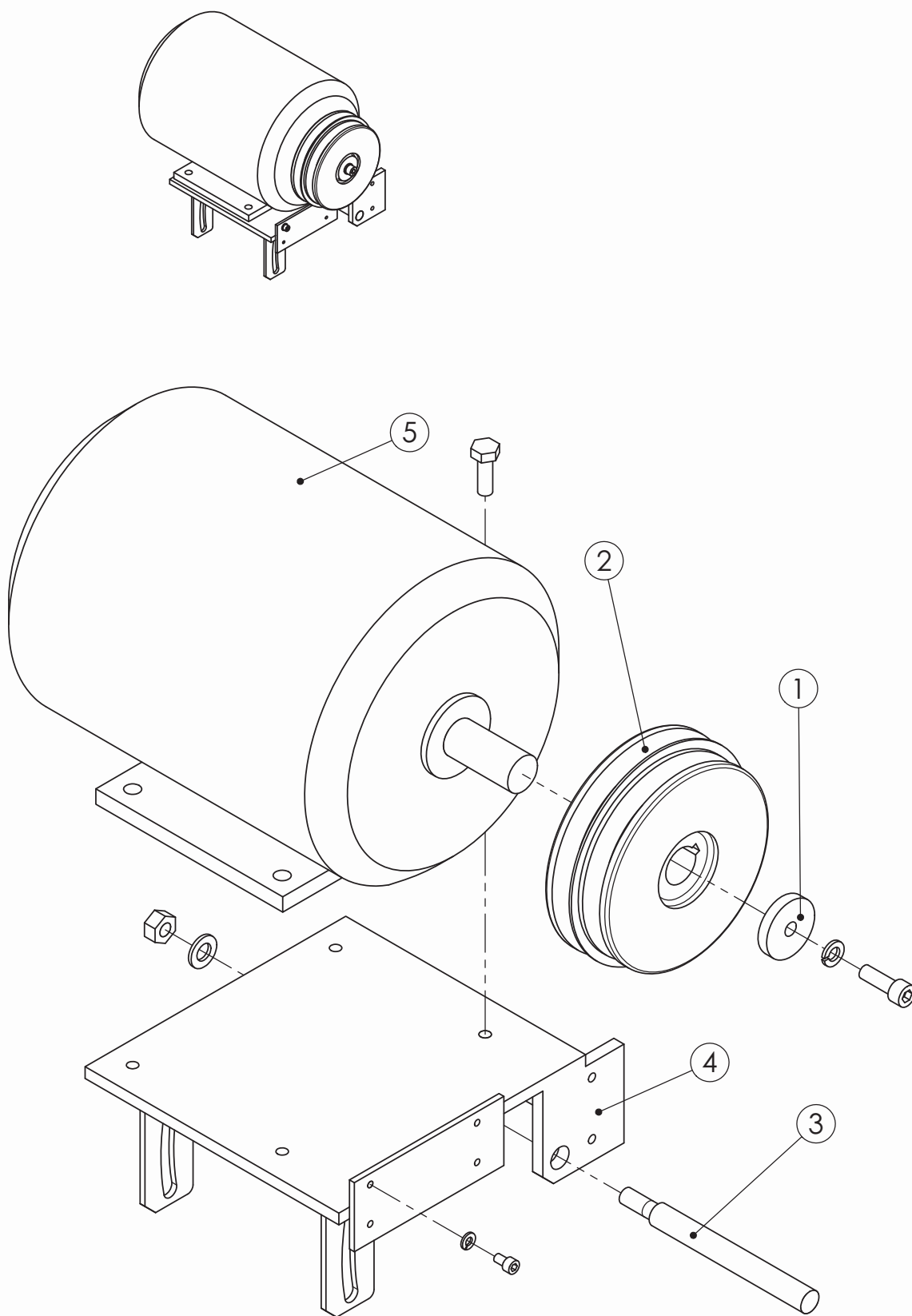



G320-EU168/AM55

20150209

馬達組 Motor Assembly

ITEM	PART NO.	PART NAME	PART NAME IN CHINESE	PART SPEC.	QTY
1	AHA-0525	Washer	墊圈		1
2	AHC-0538	Motor pulley	馬達普利		1
3	C250H-3082	Motor movable shaft	馬達活動軸		1
4	C325H-3081	Motor base plate	馬達底板		1
5	PBH5-C408-P	Motor	馬達		1

AHA-12110-1 鋼刷軸承座組

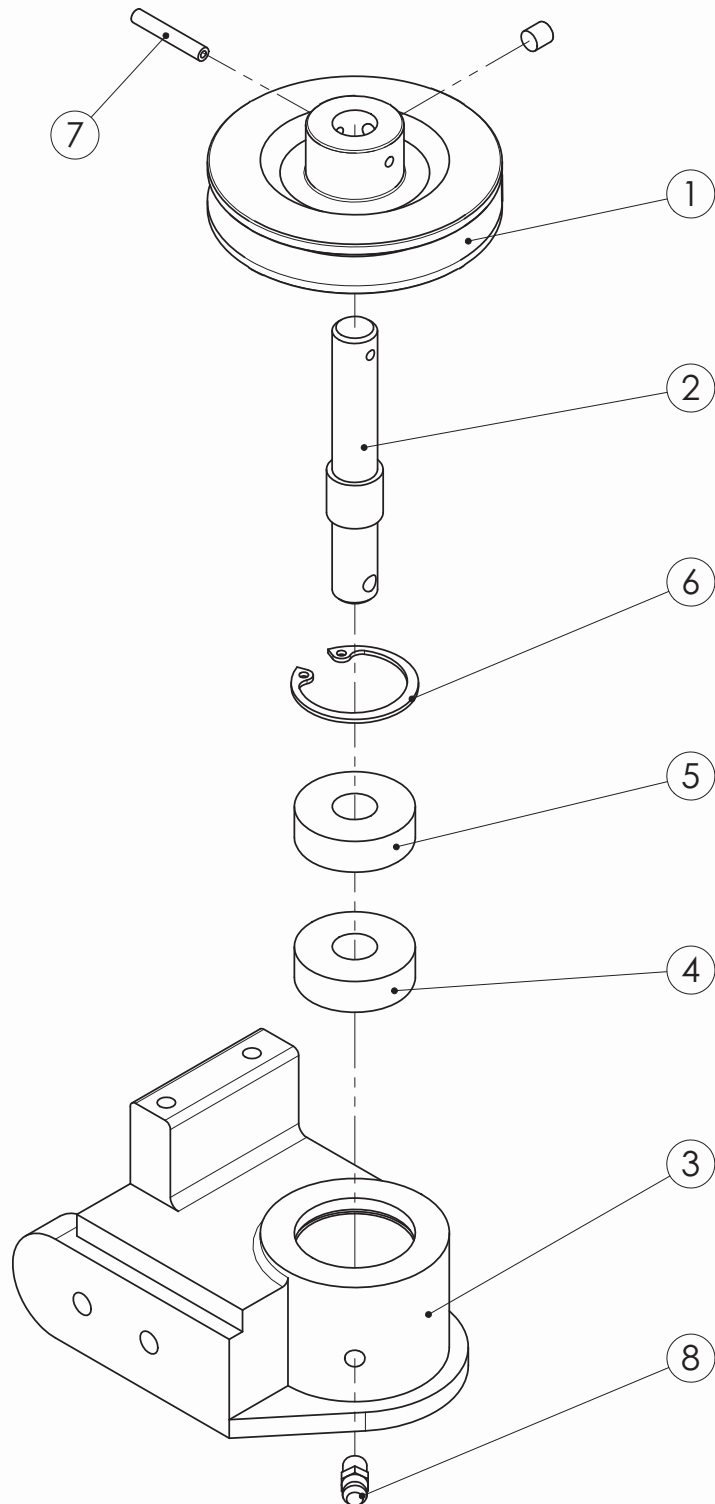
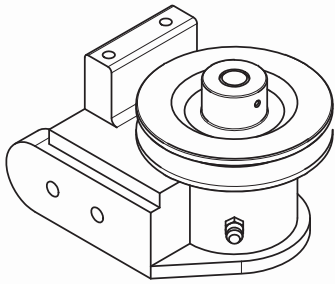



G320-EU168/AM55

20150209

AHA-12110-1 鋼刷軸承座組 Wire Brush Bearing Seat Assembly

ITEM	PART NO.	PART NAME	PART NAME IN CHINESE	PART SPEC.	QTY
1	AHA-1202	Belt wheel	鋼刷皮帶輪		1
2	AHA-1207	Belt wheel shaft	皮帶輪軸		1
3	AHA-1211	Bearing seat	軸承座		1
4	PP-14272	Bearing	軸承		1
5	PP-14272	Bearing	軸承		1
6	PP-58109	Snap ring	扣環		1
7	PRA-4-25	Spring pin	彈簧銷		1
8	PUC-020	Grease nipple	油嘴	1/4"-28UNF	1

C250H-28000 雙動虎鉗油壓缸組

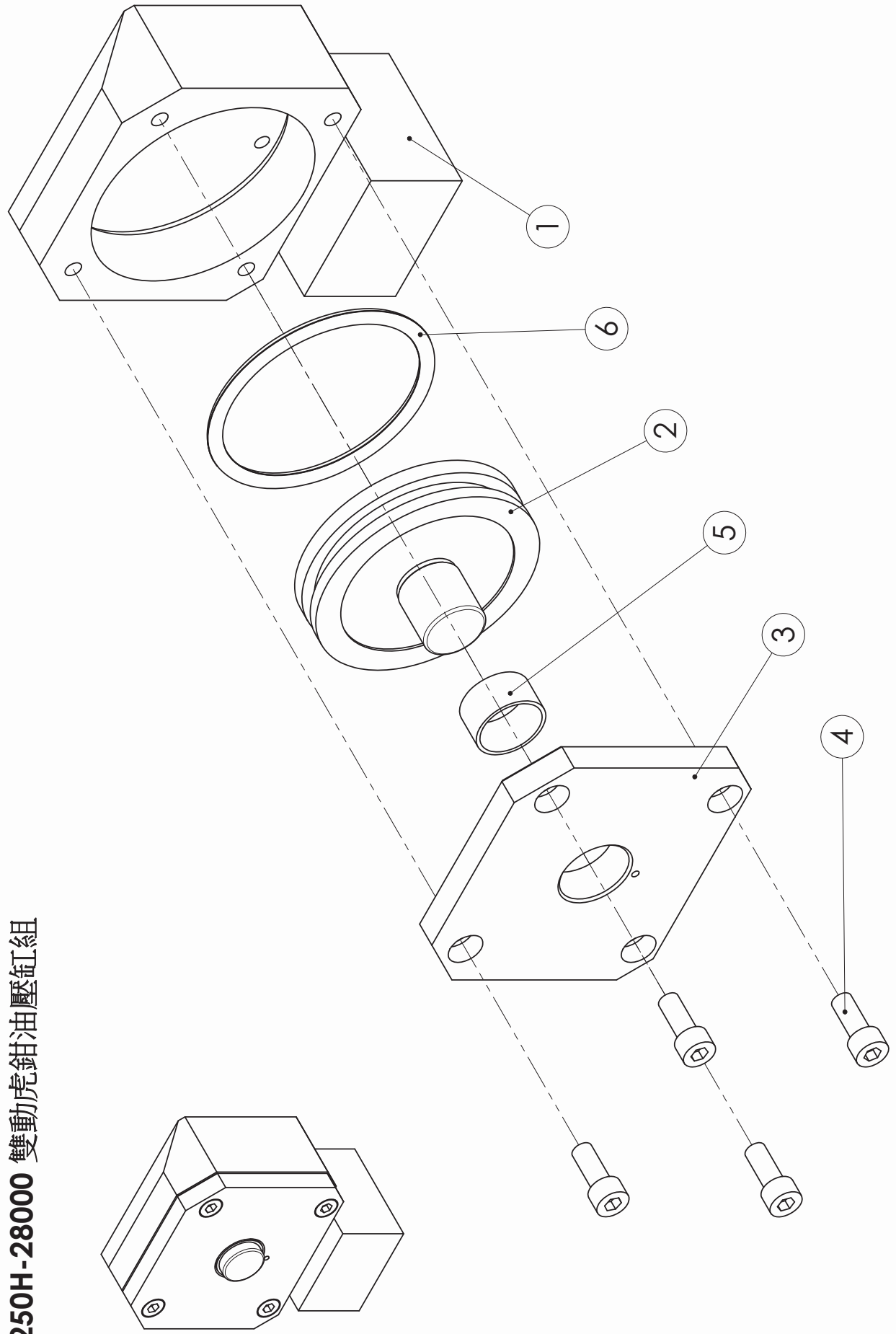



G320-EU168/AM55

20150209

C250H-28000 雙動虎鉗油壓缸組 Double Retracting Vise Hydraulic Cylinder Assembly

ITEM	PART NO.	PART NAME	PART NAME IN CHINESE	PART SPEC.	QTY
1	C250H-2801	Rear fixed vise cylinder	油缸本體		1
2	C250H-2803	Piston	活塞		1
3	C250H-2805	Piston rear cover	活塞後蓋		1
4	PBA-8-20	Hex soc cap screw	有頭內六角螺絲(公)		4
5	PP-13165	DU bushing	乾式軸承		1
6	PP-59801	O-ring	O型環		1

左導輪座組 C250H-31300

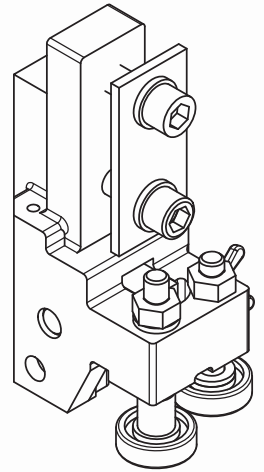
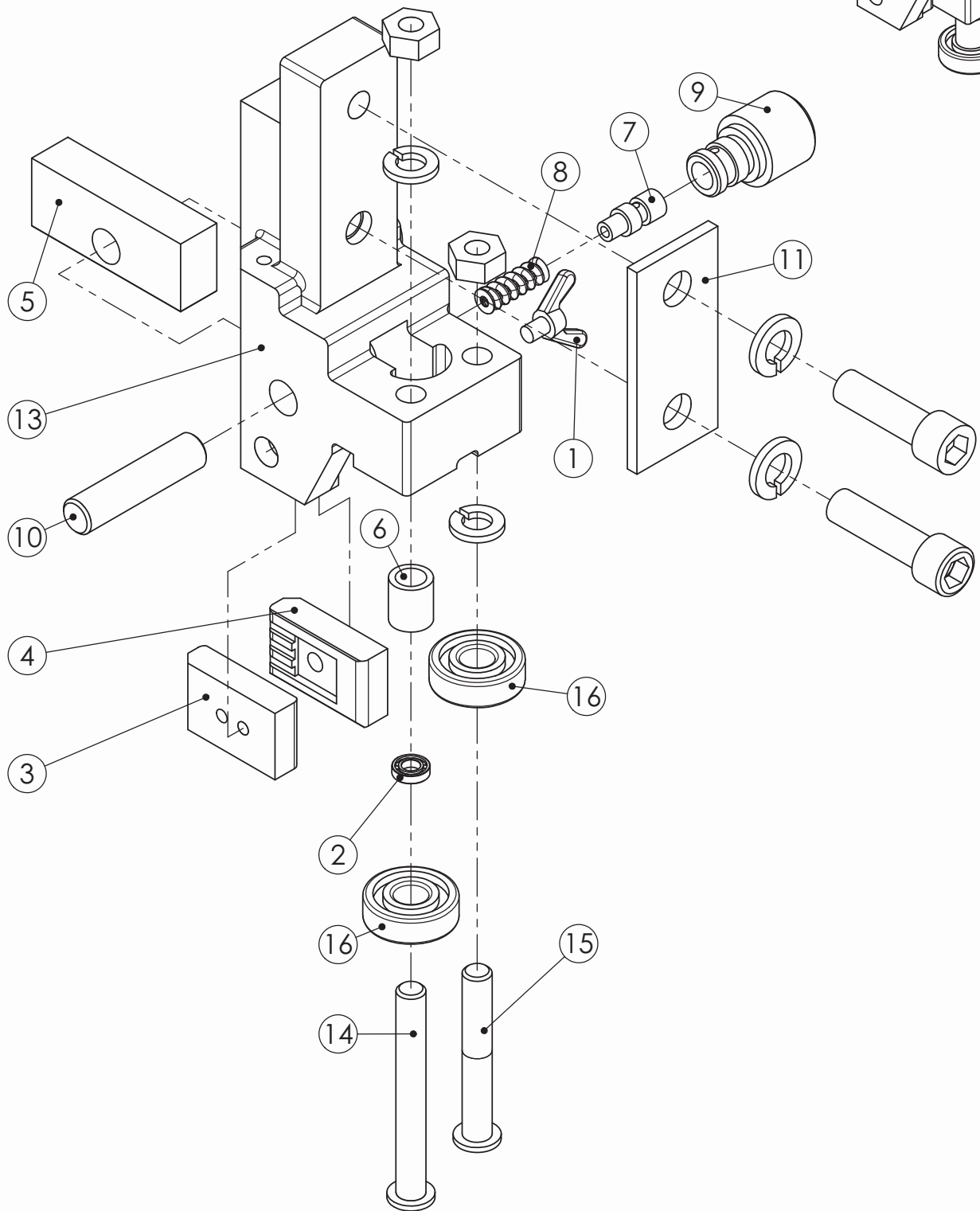

C250H-31300 左導輪座組 Left Guide Roller Assembly

ITEM	PART NO.	PART NAME	PART NAME IN CHINESE	PART SPEC.	QTY
1		Thumb screw	蝶型螺絲		1
2		Bearing	軸承		1
3	AHA-0701B	Left Fixed Insert	左固定鎢鋼片1 1/4		1
4	AHA-0702B	Left movable insert	左活動鎢鋼片1 1/4		1
5	AHA-0704A	Pressure block	下壓座(EU79用)		1
6	AHA-0708B	Washer	導輪墊圈1 1/4		1
7	AHA-0709	Left Spring plug	左簧塞		1
8	AHA-0710	Carbide insert spring	鎢鋼片彈簧		1
9	AHA-0711	Left adjusting screw	左調整螺絲		1
10	AHA-0713-1	Fixed shaft	軸承座固定軸		1
11	AHA-0719	Spacer	導輪座墊片		1
12	C250H-3013-CE	Idle wheel blade cover	上輪鋸帶護蓋		1
13	C250H-3131	left guide roller seat	左導輪座		1
14	C250H-3141	Guide roller shaft (1)	導輪軸(一)		1
15	C250H-3143A	Guide roller shaft (2)	導輪軸(二)		1
16	PP-14270	Bearing	軸承		2

C250H-31600 右導輪座組

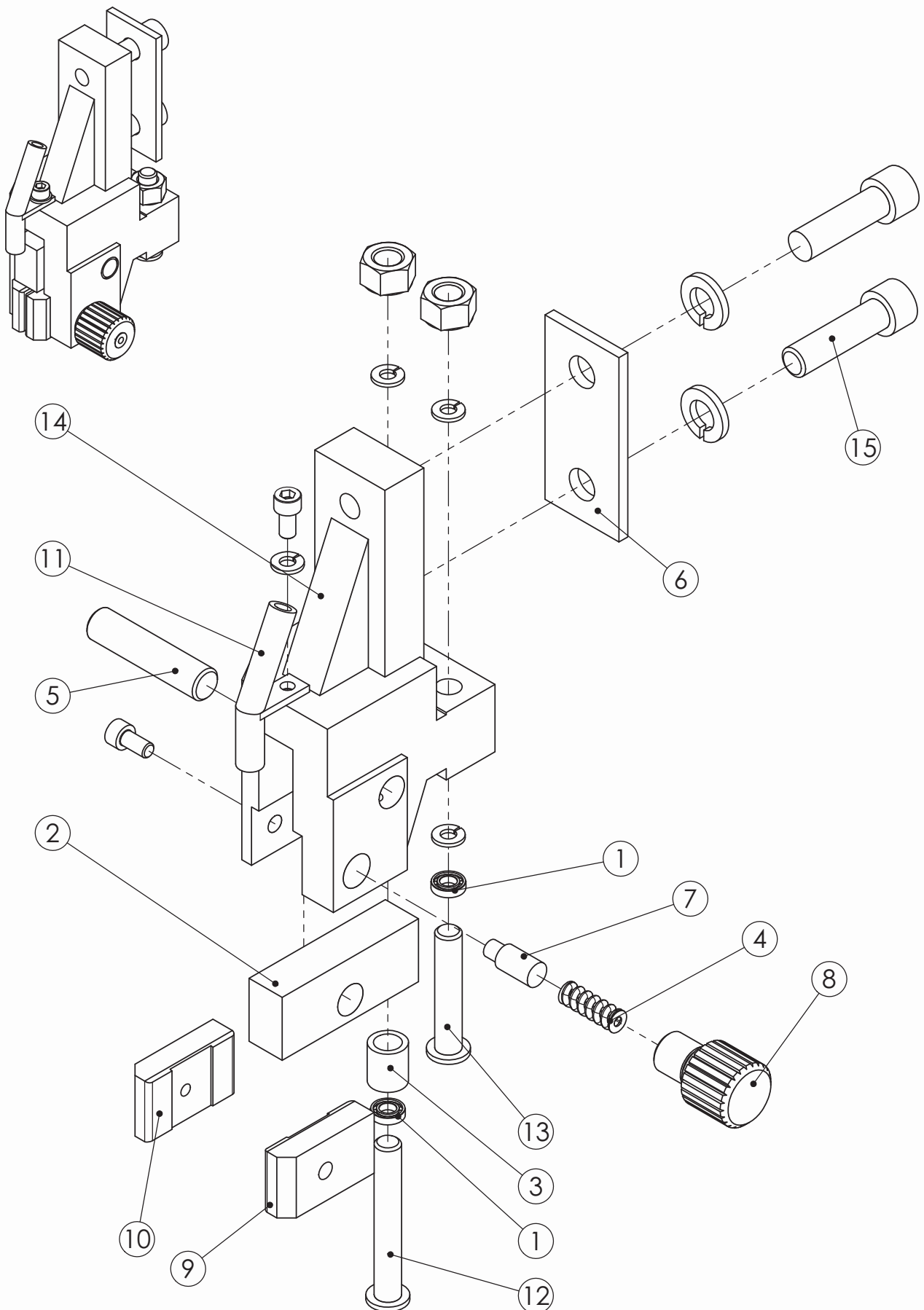

C250H-31600 右導輪座組 Right Guide Roller Assembly

ITEM	PART NO.	PART NAME	PART NAME IN CHINESE	PART SPEC.	QTY
1		Bearing	軸承		2
2	AHA-0704A	Pressure block	下壓座		1
3	AHA-0708B	Washer	導輪墊圈1 1/4		1
4	AHA-0710	Carbide insert spring	鎢鋼片彈簧		1
5	AHA-0713-1	Fixed shaft	軸承座固定軸		1
6	AHA-0719	Spacer	導輪座墊片		1
7	AHA-0741	Right Spring plug	右簧塞		1
8	AHA-0742	Right adjusting screw	右調整螺絲		1
9	AHA-0743B	Right Movable Insert	右活動鎢鋼片1 1/4		1
10	AHA-0744B	Right Fixed Insert	右固定鎢鋼片1 1/4		1
11	AHA-0745	Spray nozzle	冷卻水噴嘴		1
12	C250H-3141A	Guide roller shaft (1)	導輪軸(一)		1
13	C250H-3143A	Guide roller shaft (2)	導輪軸(二)		1
14	C250H-3161	Right guide roller seat	右導輪座		1
15	C250H-3167	Position pin	導輪座定位銷		1

C250H-33000 張力滑座滑板組

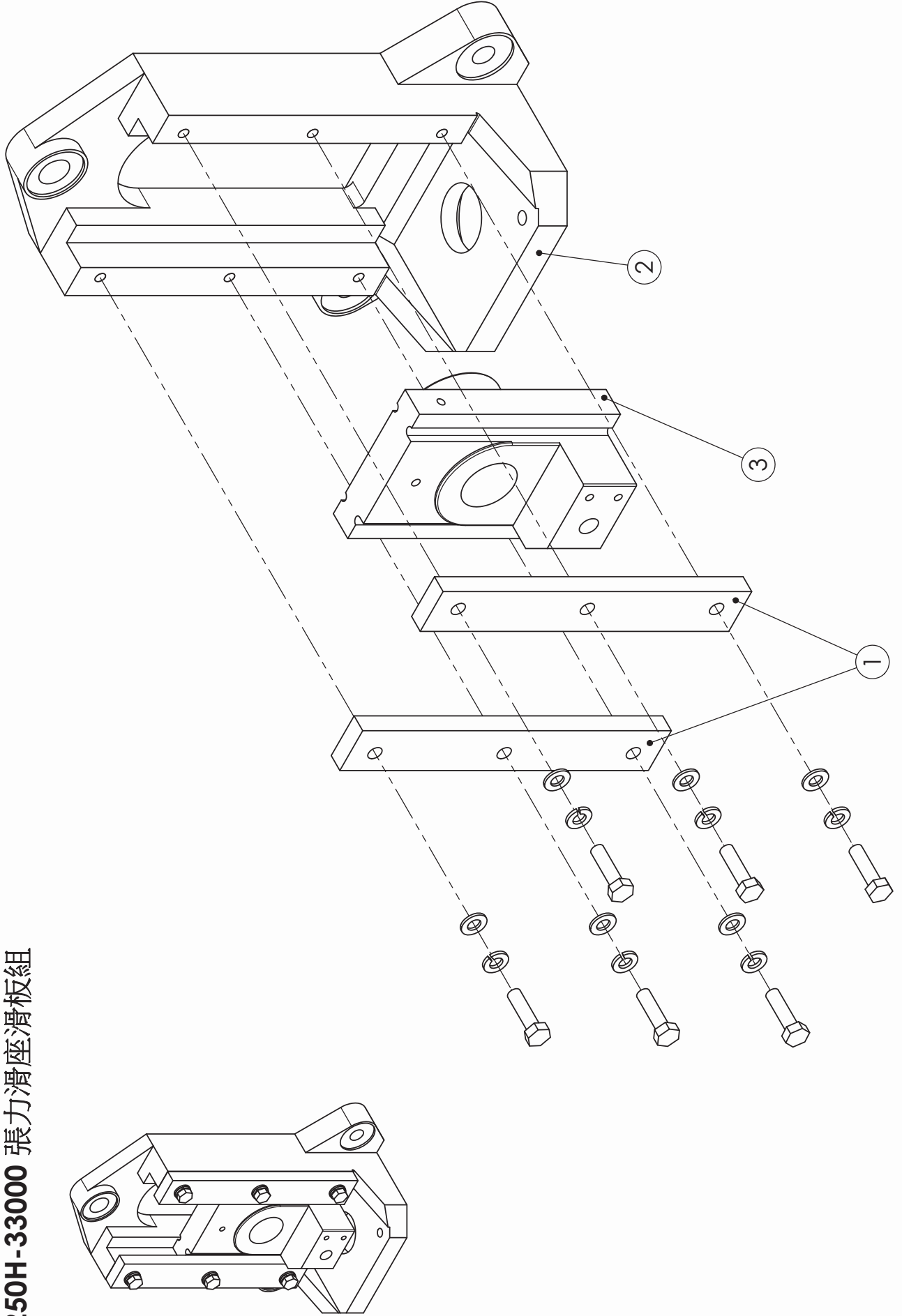



G320-EU168/AM55

20150209

C250H-33000 張力滑座滑板組 Tensioner Sliding Plate Assembly

ITEM	PART NO.	PART NAME	PART NAME IN CHINESE	PART SPEC.	QTY
1	AHA-0603	Pressure plate	導板壓條		2
2	C250H-3301	Tensioner sliding seat	張力滑座		1
3	C250H-3303	Tension adjusting sliding plate	張力調整滑板		1

C250H-33200 張力油壓缸組

ITEM	PART NO.	PART NAME	PART NAME IN CHINESE	PART SPEC.	QTY
1	C250H-3321	Cylinder front cover	張力油缸前蓋		1
2	C250H-3325	Piston and shaft	活塞及桿		1
3	C250H-3327	Tube	缸筒		1
4	C250H-3329	Spring	彈簧		1
5	PLA-10-140	Hexagon screw	外六角頭螺絲	M10XP1.5X140	2
6	PLA-10-160	Hexagon screw	外六角頭螺絲	M10XP1.5X160	2
7	PP-51037	Oil seal	油封	32.45.7VB	1
8	PP-59030	O-ring	O型環	P-9	1
9	PP-59120	O-ring	O型環	P-32	1
10	PP-59801	O-ring	O型環		1
11	PP-59802	O-ring	O型環	P-90	1

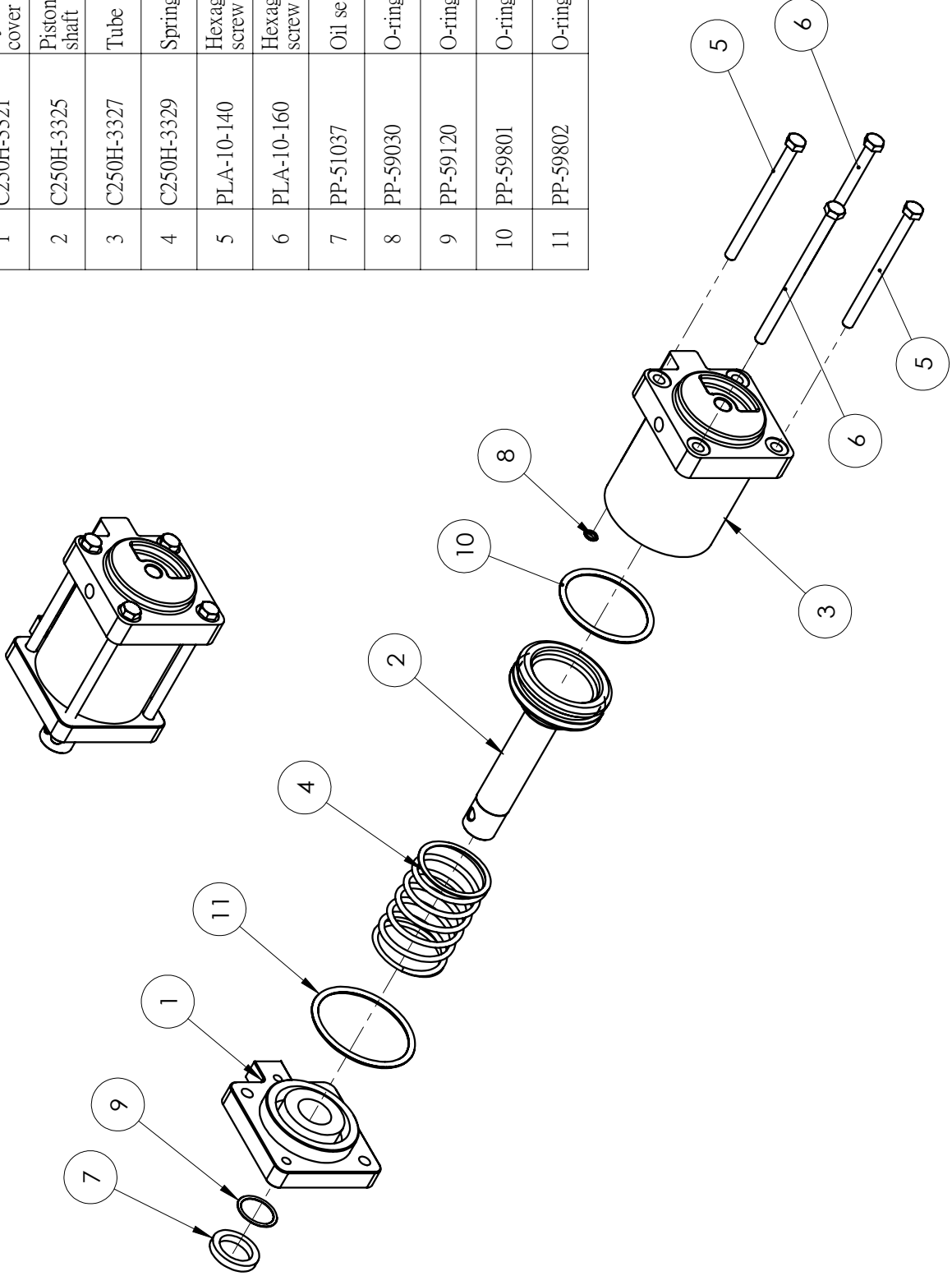

C250H-40000 除屑機組 Chip conveyor assembly

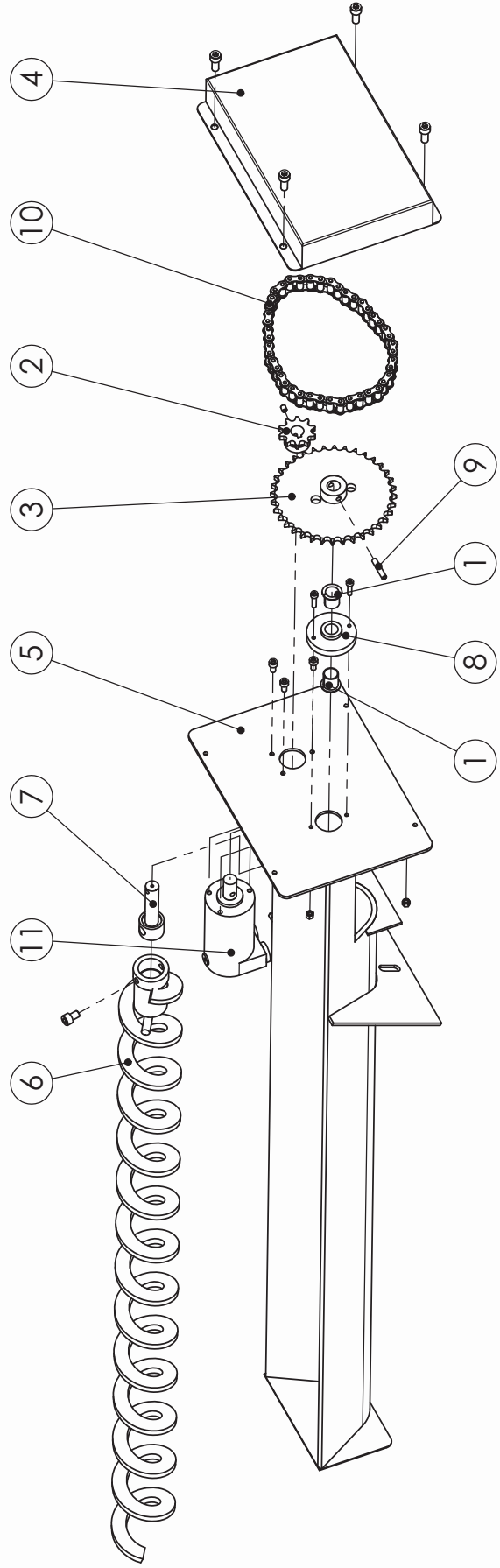
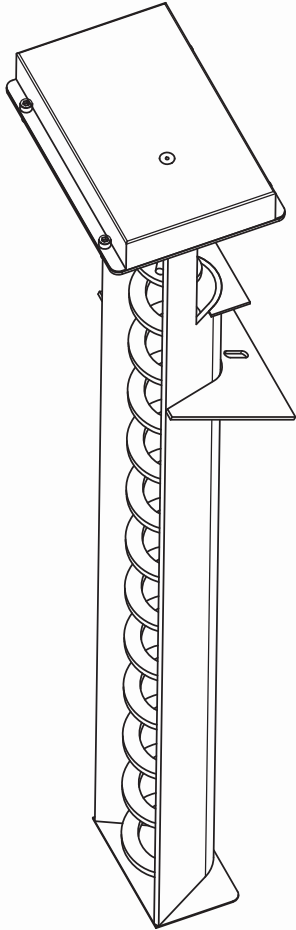

C250H-40000 除屑機組 Chip conveyor assembly

ITEM	PART NO.	PART NAME	PART NAME IN CHINESE	PART SPEC.	QTY
1	PP13374	Oil-less bushing	凸緣自潤襯套		2
2	PP-10000	Drive sprocket <small>(small)</small>	傳動鏈輪-小		1
3	PP-10001	Sprocket	鏈輪		1
4	PP-10002	Cover	鏈齒蓋板		1
5	PP-10003	Receiving hopper	除屑槽		1
6	PP-10004	Chip spiral	除屑螺旋		1
7	PP-10005	Drive shaft	傳動軸心		1
8	PP-10006	Shaft seat	軸座		1
9	PP-10007	Pin	插銷		1
10	PP-19061	Roller chain	鍊條		*
11	PP-31640-1	Hydraulic motor	油壓馬達		1

C320G-11000 主軸組

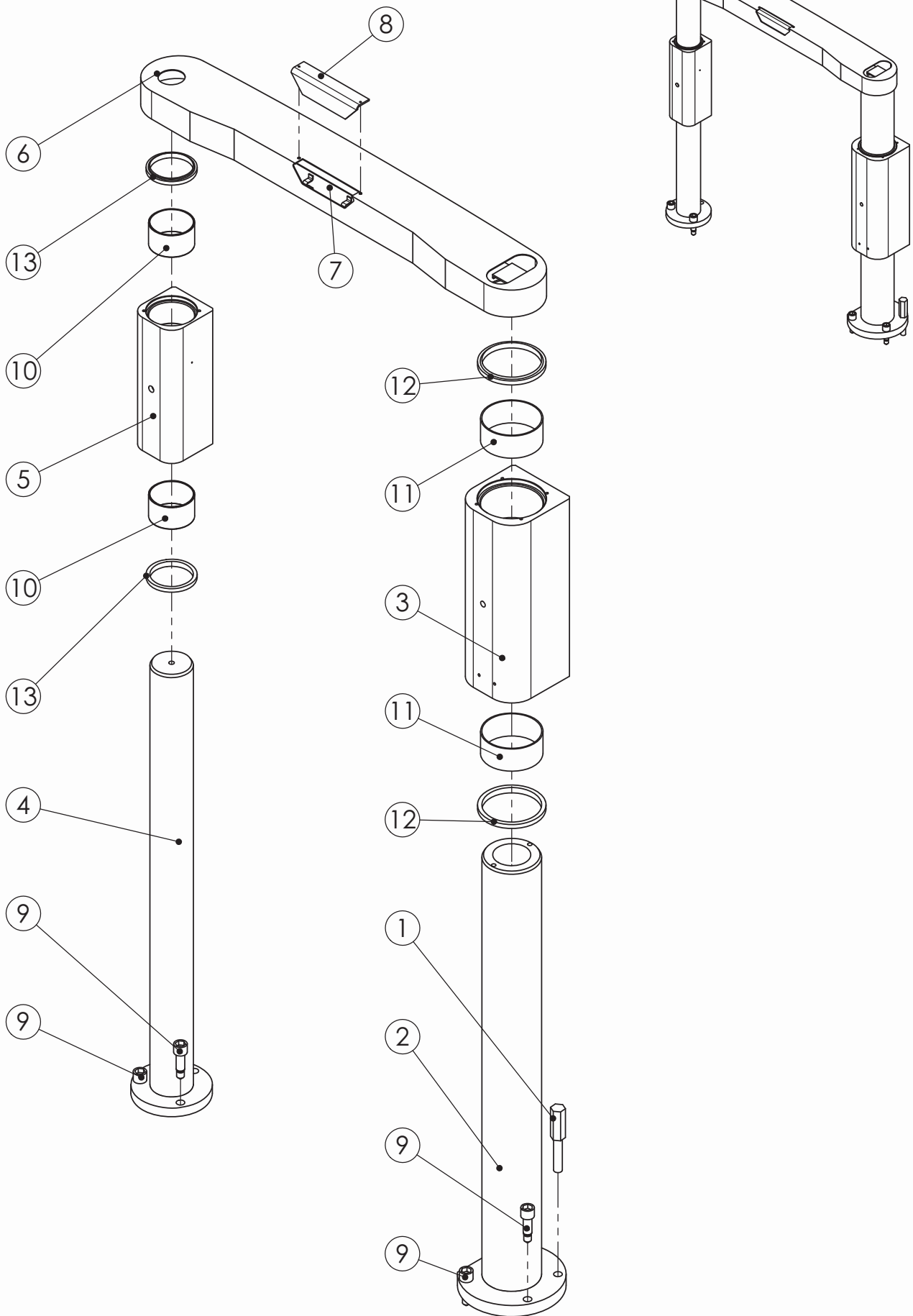

C320G-11000 主軸組 Main Shaft Assembly

ITEM	PART NO.	PART NAME	PART NAME IN CHINESE	PART SPEC.	QTY
1	AGC-1030	Lower limit positioning rod	下限定位支桿		1
2	C320G-1101	Main shaft	大主軸		1
3	C320G-1103	Main shaft assembly	大軸套		1
4	C320G-1121	Sub shaft	小主軸		1
5	C320G-1123	Sub shaft sleeve	小軸套		1
6	C320G-1131A	Cross beam	橫梁		1
7	C320G-1134A	Cross beam rear cover	橫梁後蓋板		1
8	C320G-1136A	Acrylic lamp shade	壓克力燈罩		1
9	C320G-1154	Fixed hex soc bolt	內六角固定螺栓		5
10	PP-13281	DU bushing	乾式軸承		2
11	PP-13310C	DU bushing	乾式軸承		2
12	PP-51140	duster seal	防塵套		2
13	PP-51196A	duster seal	防塵套(軟橡皮)		2

C320G-33500 減速機整組

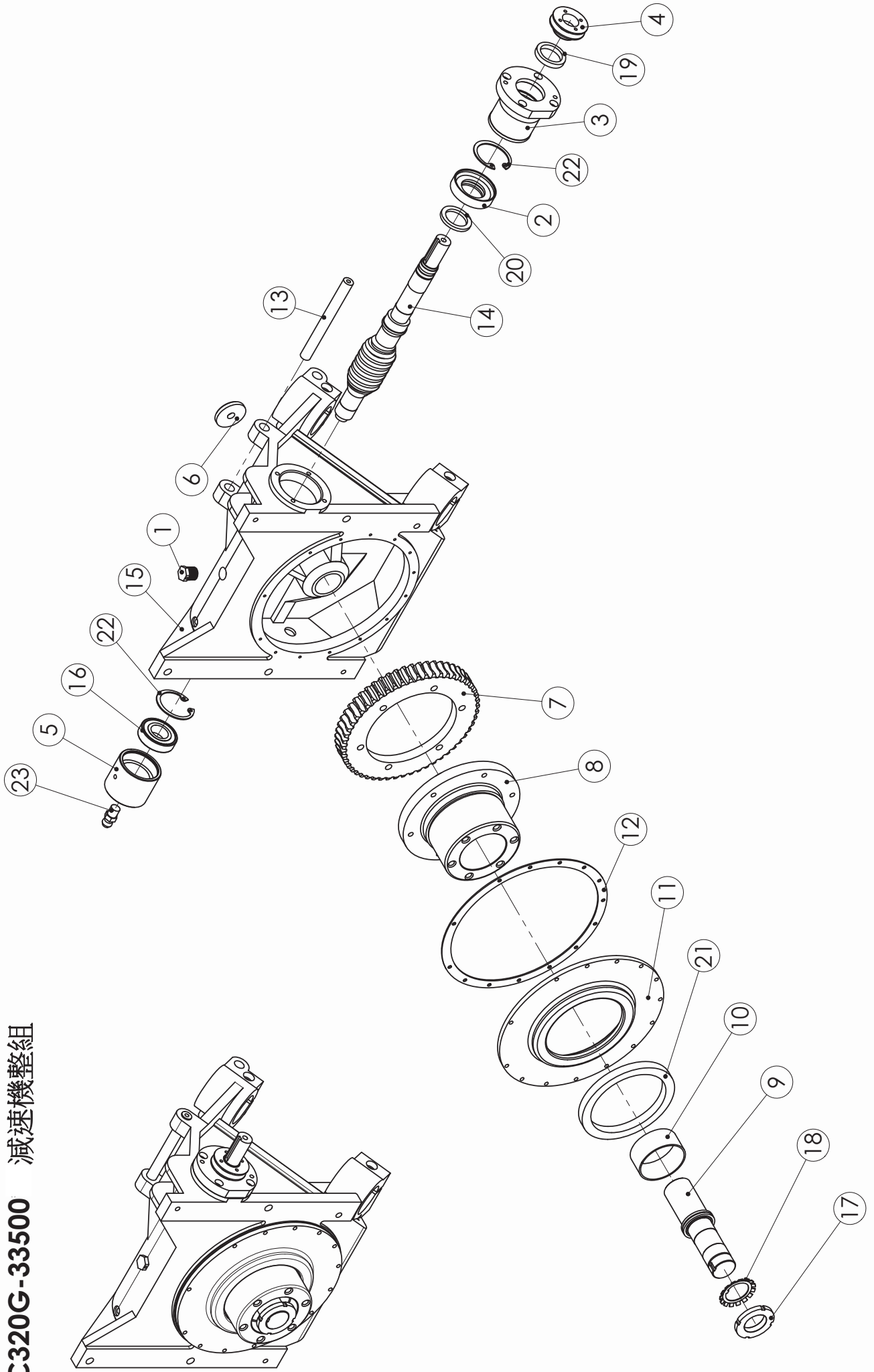

C320G-33500 減速機整組 Gear Reducer Assembly

ITEM	PART NO.	PART NAME	PART NAME IN CHINESE	PART SPEC.	QTY
1	AHA-0307	Plug	透氣塞頭		1
2	AHA-0314	Fixed seat cover	固定座蓋		1
3	AHA-0319	Fixed seat (1)	固定座(一)		1
4	AHA-0320	Wire brush pulley	鋼刷普利		1
5	AHA-0326	Fixed seat (2)	固定座(二)		1
6	AHA-0403	Washer	下輪鎖緊墊圈		1
7	AHA-0404-1	Worm gear	蝸輪		1
8	AHA-0406	Worm gear fixed seat	蝸輪固定座		1
9	AHA-0407	Drive wheel shaft	下輪軸		1
10	AHA-0431	Bearing washer	軸承墊圈		1
11	AHA-0433	Oil fixed plate	油封固定盤		1
12	AHA-0454	Rubber asher	耐油墊圈		1
13	C250H-3085	Motor position shaft	馬達定位軸		1
14	C300H-3353	Worm shaft	蝸桿		1
15	C320G-3351	Gear reducer body	減速機本體		1
16	PP-14131	Bearing	軸承		1
17	PP-14908	Fixed nut	固定螺母		1
18	PP-14958	Stop ring	止動環		1

19	PP-51070	Oil Seal	油封		1
20	PP-51080	Oil Seal	油封		1
21	PP-51090A	Oil Seal	油封		1
22	PP-58103	Interlock	內鎖		2
23	PUC-005	Grease nipple	油嘴		1

C325H-32000 急降桿組

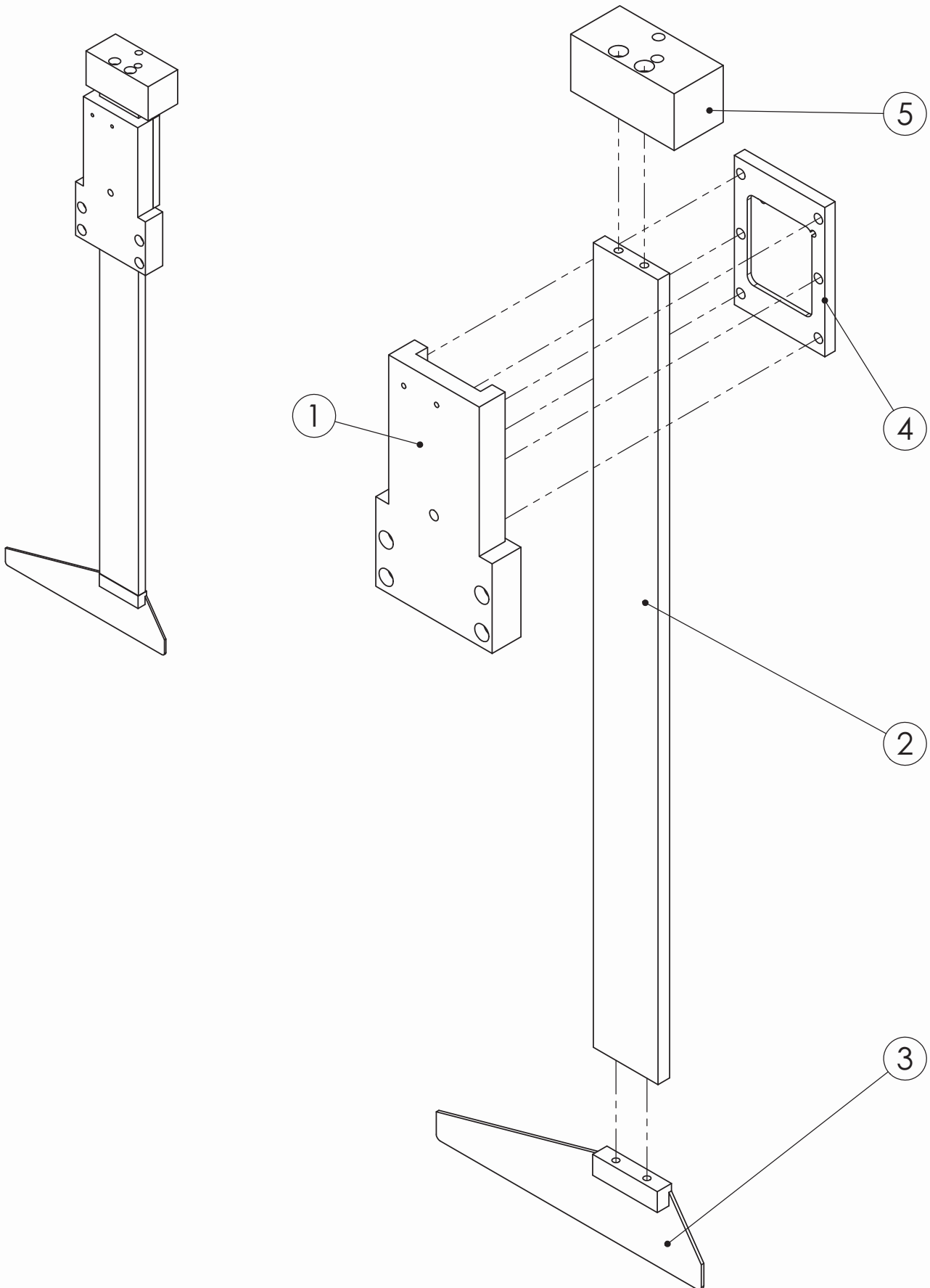

C325H-32000 急降桿組 Quick Approach Assembly

ITEM	PART NO.	PART NAME	PART NAME IN CHINESE	PART SPEC.	QTY
1	C250H-3205	Quick approach fixed seat	急降桿固定座		1
2	C325H-3201	Quick approach bar	急降桿		1
3	C325H-3203	Quick approach stopper	急降桿擋板		1
4	AHA-1754	Quick approach bar seat	急降桿座蓋		1
5	AHA-1756	Limit switch seat	限動開關座		1

上輪組

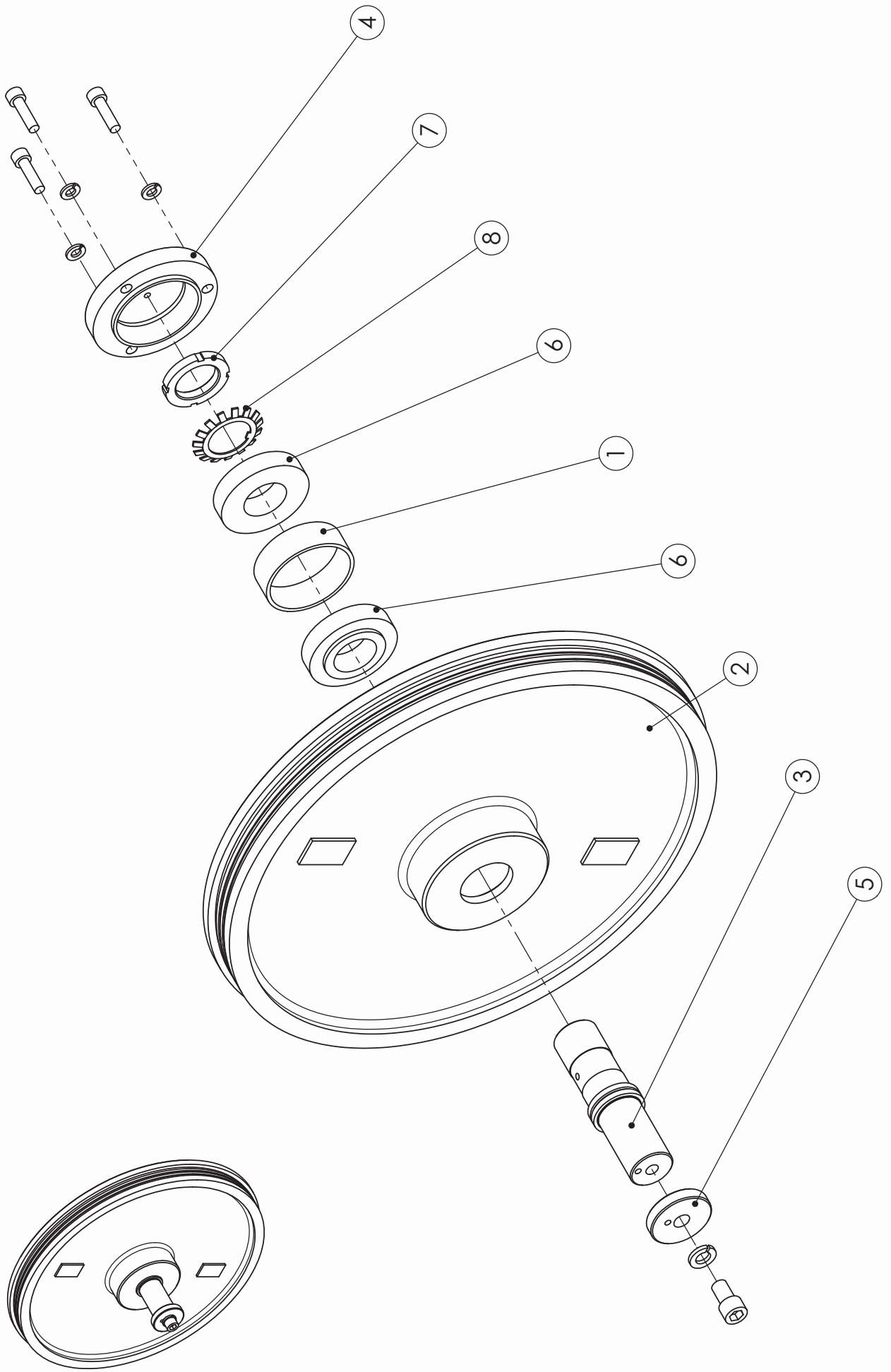



G320-EU168/AM55

20150209

上輪組 Idle Wheel Assembly

ITEM	PART NO.	PART NAME	PART NAME IN CHINESE	PART SPEC.	QTY
1	AHA-0637	Idle wheel bearing washer	上輪軸承墊圈		1
2	C250H-3031	Idle wheel	上輪		1
3	C250H-3033	Idle wheel shaft	上輪軸		1
4	C250H-3037	Idle wheel shaft cover	上輪軸蓋		1
5	C250H-3045	Fixed washer	上輪軸固定華司		1
6	PP-14613	Ball bearing	滾錐軸承		2
7	PP-14907	Fixed nut	固定螺母		1
8	PP-14957	Stop ring	止動環		1

托架組

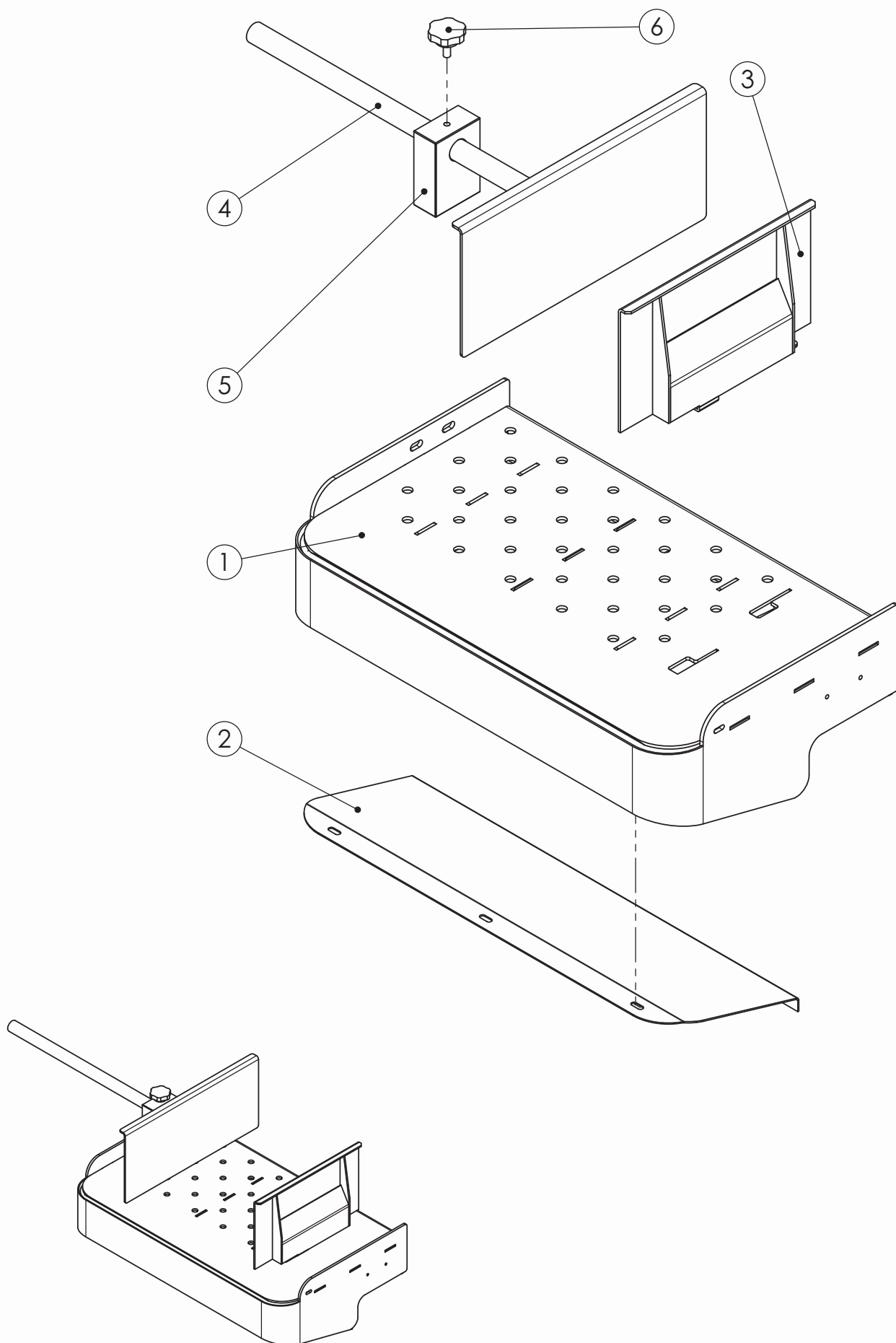



G320-EU168/AM55

20150209

托架組 Tray Assembly

ITEM	PART NO.	PART NAME	PART NAME IN CHINESE	PART SPEC.	QTY
1	C320G-1201A	Bracket	托架		1
2	C320G-1208A	Bracket splash shield	托架遮水板		1
3	C320G-1209A	Right bracket	托架右板		1
4	C320G-1211A	Left bracket	托架左板		1
5	C320G-1215A	Bracket guiding rod fixed seat	托架導桿固定座		1
6	PP-53010	Knob screw	梅花螺絲 (含塞銅)		1

固定床面組

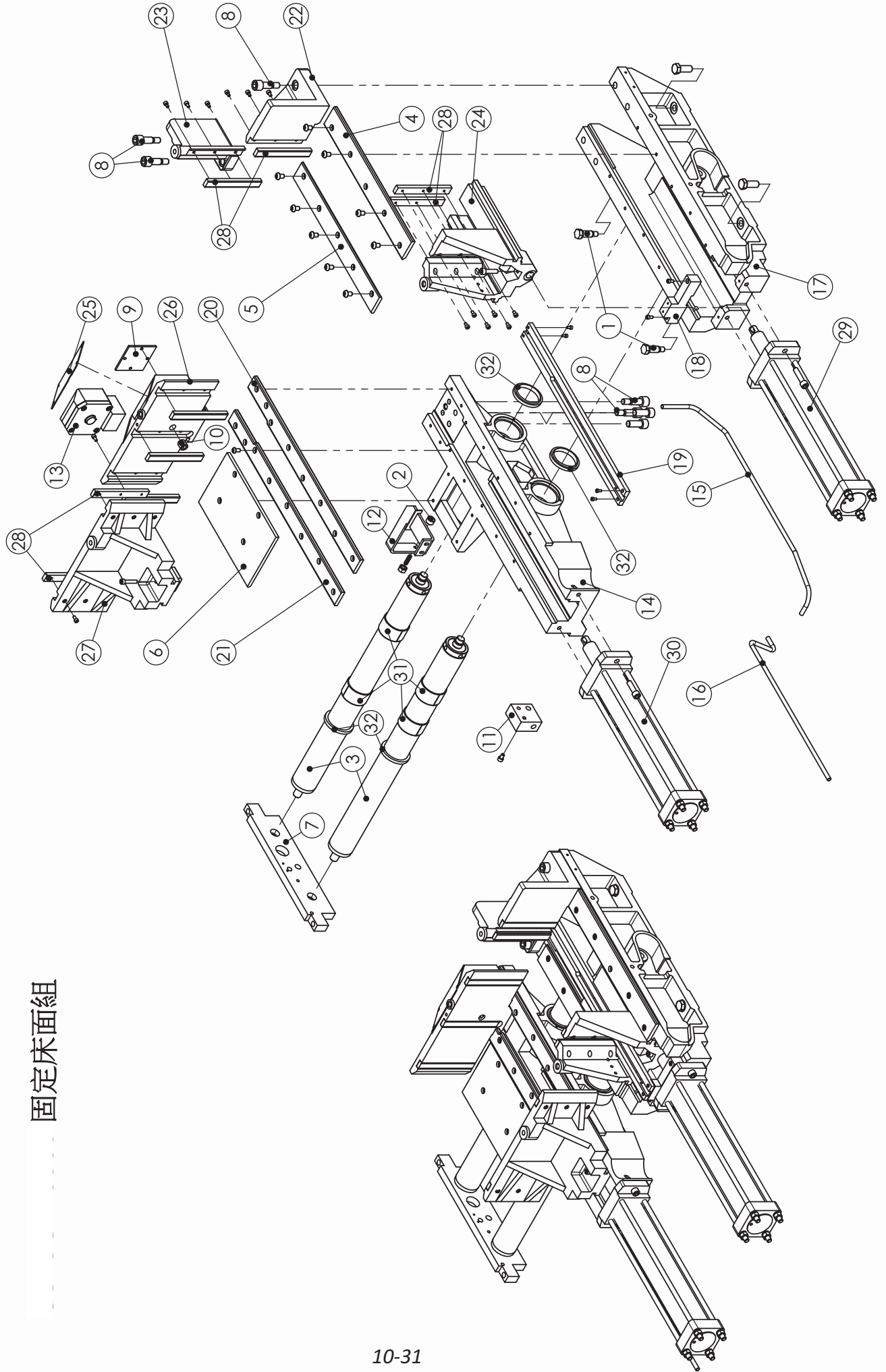

固定床面組 Fixed Bed Assembly

ITEM	PART NO.	PART NAME	PART NAME IN CHINESE	PART SPEC.	QTY
1	AHA-0122D	Fixed hexagon bolt	外六角固定螺栓		2
2	AHA-1539	Screw (sensor)	感應器螺桿M8		1
3	AHA-1601B	Feeding shaft	送料軸		2
4	AHC-0234A	Bed steel plate	床面鋼板(一)大		1
5	AHC-0234B	Bed steel plate 2	床面鋼板(二)小		1
6	AHC-1524Y2	cover	遮板		1
7	C250H-2029	Fixed bracket	送料軸固定板		1
8	C250H-2807	Position pin	雙動虎鉗定位銷		6
9	C250H-2809	Spring shield	彈簧擋板		1
10	C250H-2811	Stop screw	止動螺絲 後固定虎鉗		1
11	C250H-2815	Vise manifold plate	虎鉗油路板		1
12	C250H-2885A	Feeding front limit sensing seat	送料前限感應座		1
13	C250H-28000	Double retracting vise hydraulic cylinder assembly	雙動虎鉗油壓缸組		1
14	C320G-2011	Feeding bed	送料床面		1
15	C320G-2813	Double retracting vise tube	雙動虎鉗鋼管		1
16	C320G-2861A	Feeding seat tube	送料座鋼管		1
17	C325H-2001	Bed	床面		1
18	C325H-2006	Fixed plate	前鋸線鋼板固定座		1

19	C325H-2008	Blade plate	前鋸線鋼板		1
20	C325H-2013	Feeding bed plate 1	送料床面鋼板(一)		1
21	C325H-2015	Feeding bed plate 2	送料床面鋼板(二)		1
22	C325H-2201	Front fixed vise	前固定虎鉗(前)		1
23	C325H-2203	Front fixed vise	前固定虎鉗(後)		1
24	C325H-2215	Front movable vise	前活動虎鉗		1
25	C325H-2220	Feed double retracting vise	送料雙動虎鉗蓋		1
26	C325H-2221	Rear fixed vise	後固定虎鉗		1
27	C325H-2223	Rear movable vise	後活動虎鉗		1
28	C325H-2241	Vise Plate	虎鉗鋼板		9
29	C325H-23000	Vise hydraulic cylinder	虎鉗油壓缸		1
30	C325H-23000	Vise hydraulic cylinder	虎鉗油壓缸-1		1
31	PP-13260	DU bushing	乾式軸承6540		4
32	PP-51146	duster seal	防塵套		4

底座組

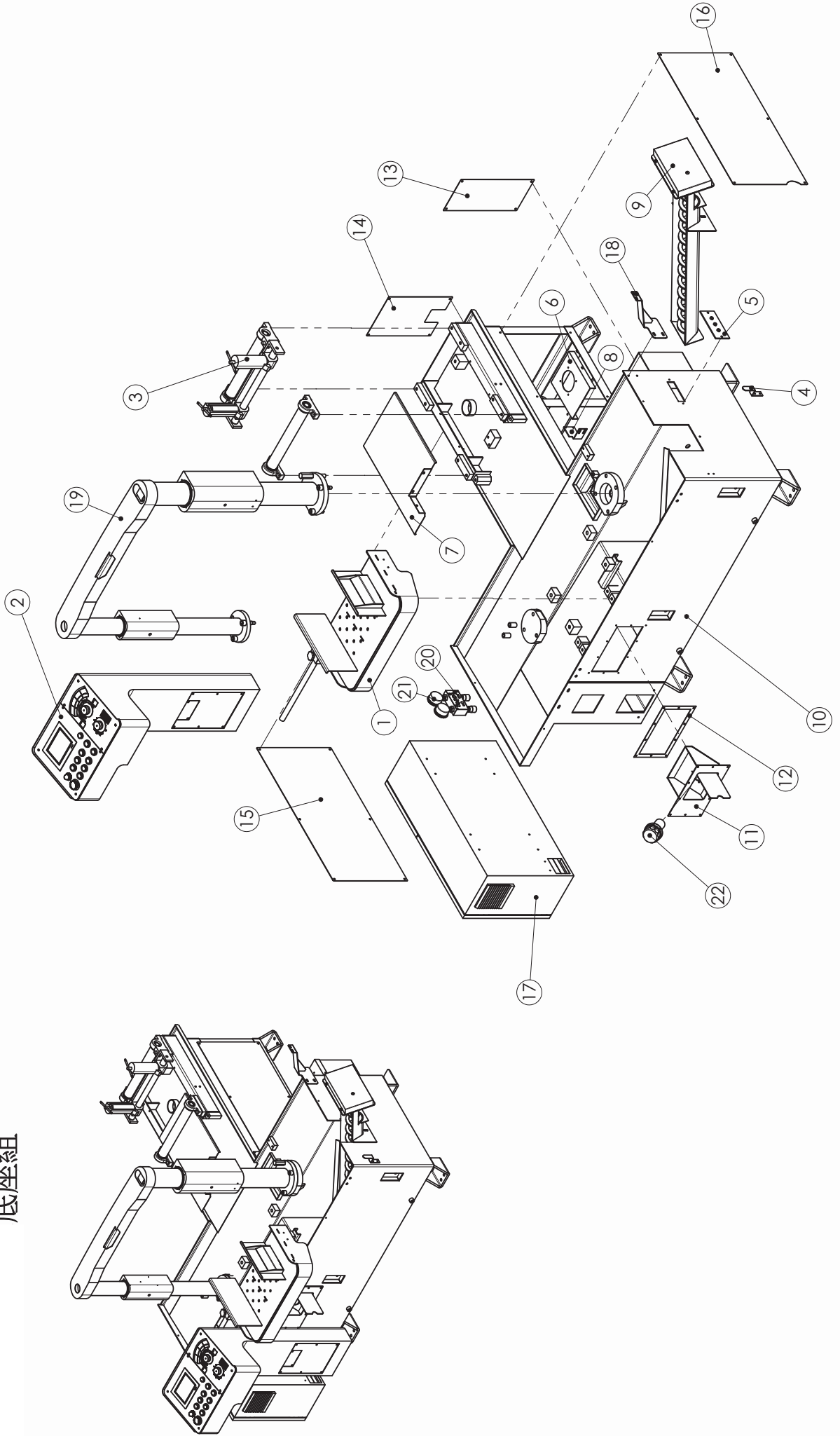



G320-EU168/AM55

20150209

底座組 Base Assembly

ITEM	PART NO.	PART NAME	PART NAME IN CHINESE	PART SPEC.	QTY
1		Tray assembly	托架組		1
2		Control box assembly	操作箱組		1
3		Vertical roller assembly	側邊滾輪組		1
4	AHA-1309	Hose bracket	軟管架		1
5	AHG-0138A	Fitting seat	水管接頭座		1
6	C250H-0136	Pump fixed seat cover	泵浦固定座蓋		1
7	C250H-1281	Feeding shaft cover	送料軸護蓋		1
8	C250H-2030B	Limit switch seat	限動開關座(CE用)		1
9	C250H-40000	Chip conveyor assembly	除屑機組合		1
10	C320G-1001A-2	Base	底座		1
11	C320G-1003A	Oil tank cover	油箱蓋		1
12	C320G-1004A	Oil tank gasket	油箱墊片		1
13	C320G-1060	Cover	右後蓋		1
14	C320G-1061A	Left rear cover	左後蓋		1
15	C320G-1063A	Base side cover - L2	後左前蓋		1
16	C320G-1067	Cover	後右後蓋		1
17	C320G-1310	Control box door	控制箱門		1
18	C320G-1858A	Safety fence fixed plate	防護欄固定板		1

19	C320G-11000	Main shaft assembly	主軸組		1
20	PP-43127A	Pressure regulator	減壓閥	RSW-902	1
21	PP-43311	Pressure gauge	壓力表		2
22	PP-43320	Filler breather filter	注油器		1

側邊滾輪組

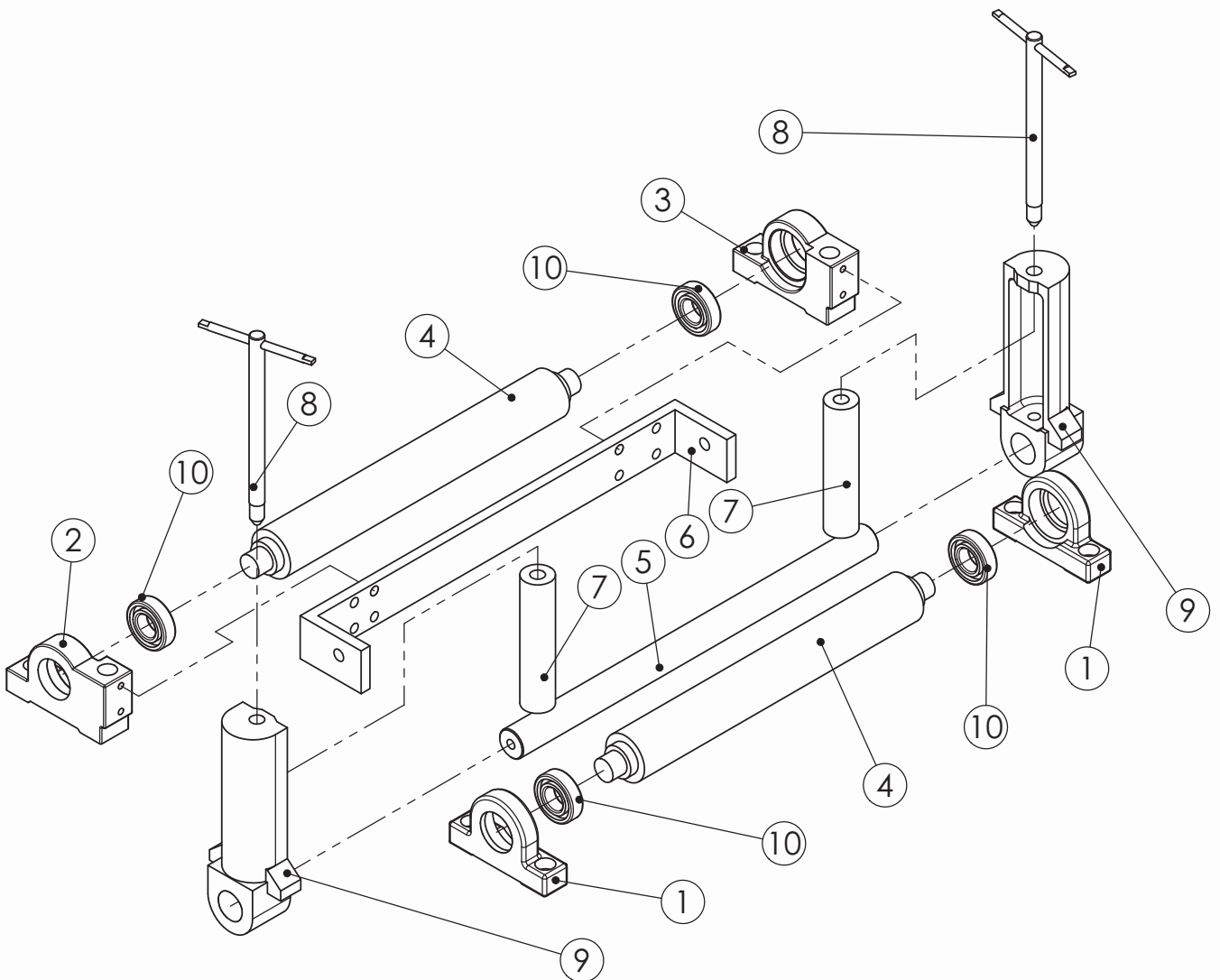
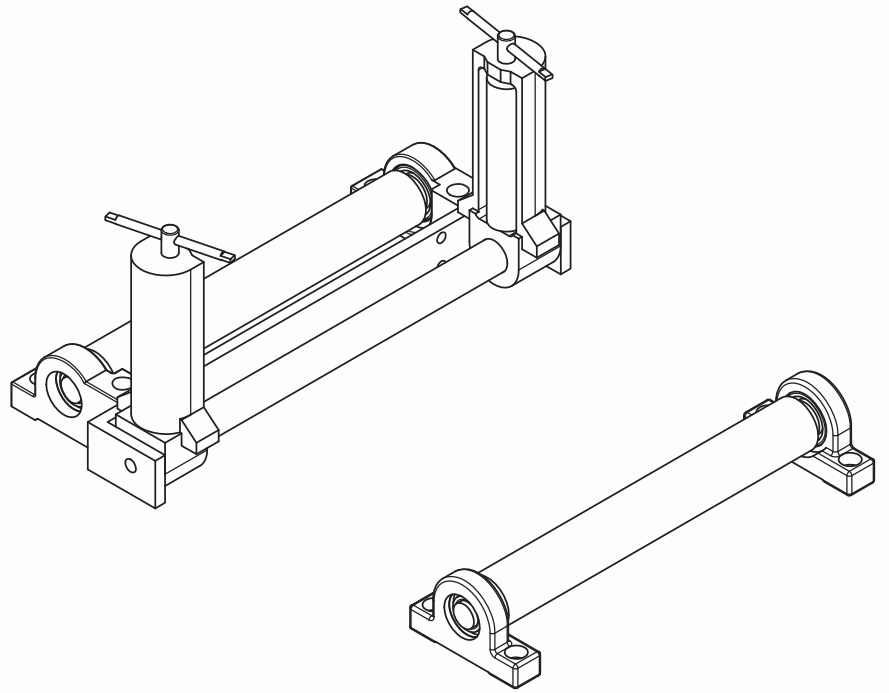

側邊滾輪組 Vertical Roller Assembly

ITEM	PART NO.	PART NAME	PART NAME IN CHINESE	PART SPEC.	QTY
1	C325H-1253	Roller fixed shaft	滾輪固定座		2
2	C325H-1257	Roller fixed seat (right)	滾輪固定座(右)		1
3	C325H-1255	Roller fixed seat (left)	滾輪固定座(左)		1
4	AHC-1625	Roller	滾輪		2
5	AHC-1662A	Fixed shaft	側滾輪固定軸		1
6	AHC-1675A	Vertical roller stopper	側滾輪擋板		1
7	OPR-5013C	Vertical roller	側滾輪		2
8	OPR-5014B	Vertical roller shaft and handle	側滾輪軸及把手		2
9	OPR-5015C	Vertical roller seat	側滾輪座		2
10	PP-14275	Bearing	軸承		4

減速機/馬達組

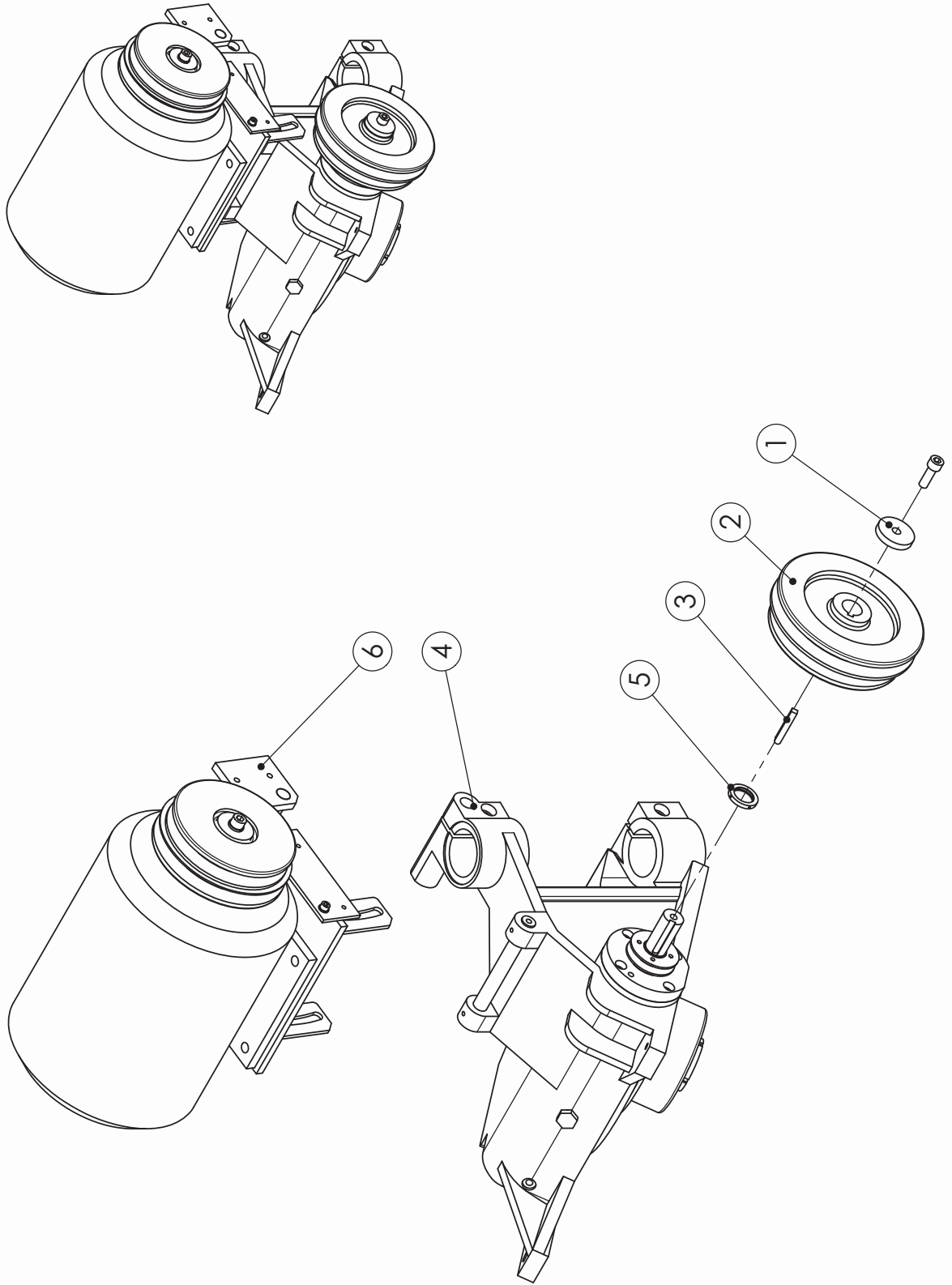



G320-EU168/AM55

20150209

減速機/馬達組

ITEM	PART NO.	PART NAME	PART NAME IN CHINESE	PART SPEC.	QTY
1	AHA-0525	Washer	墊圈		1
2	AHC-0514	Gear reducer pulley	減速機普利		1
3	C250H-3354	Gear reducer pulley key	減速機普利方鍵		1
4	C320G-33500	Gear reducer assembly	減速機組		1
5	MAE-2025	Idle wheel shaft washer	上輪軸墊圈		1
6	PBH5-C408	Motor assembly	馬達組		1

電器箱組

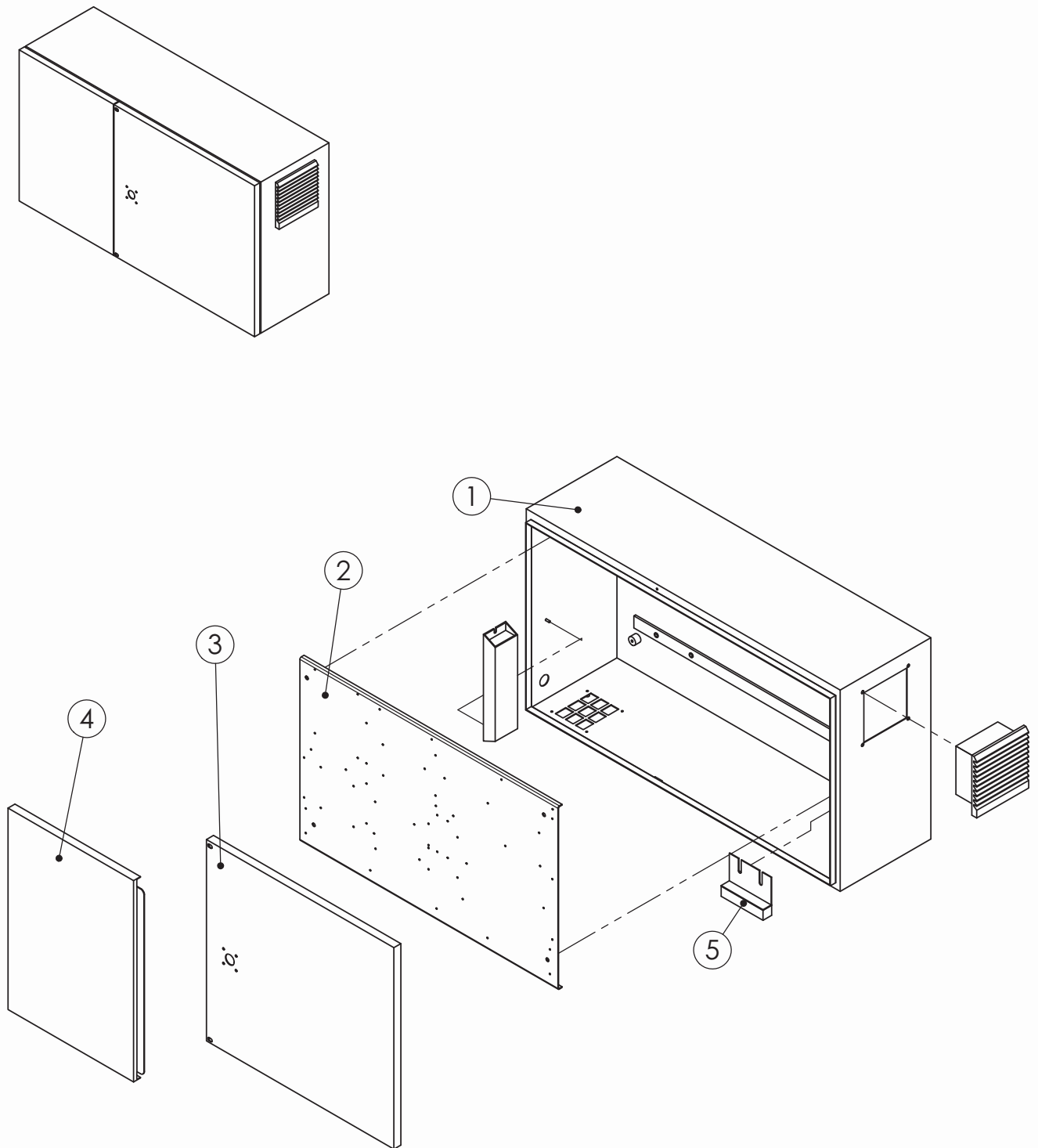



G320-EU168/AM55

20150209

電器箱組 Electrical Compartment

ITEM	PART NO.	PART NAME	PART NAME IN CHINESE	PART SPEC.	QTY
1	C320G-1301A	Control box	控制箱		1
2	C320G-1305A	Control box base plate	控制箱底板		1
3	C320G-1310A-P1	Control box door-P1	控制箱門-P1		1
4	C320G-1310A-P2	Control box door-P2	控制箱門-P2		1
5	C320G-1320A	Wire fixed Board	電線固定板		1

操作箱組

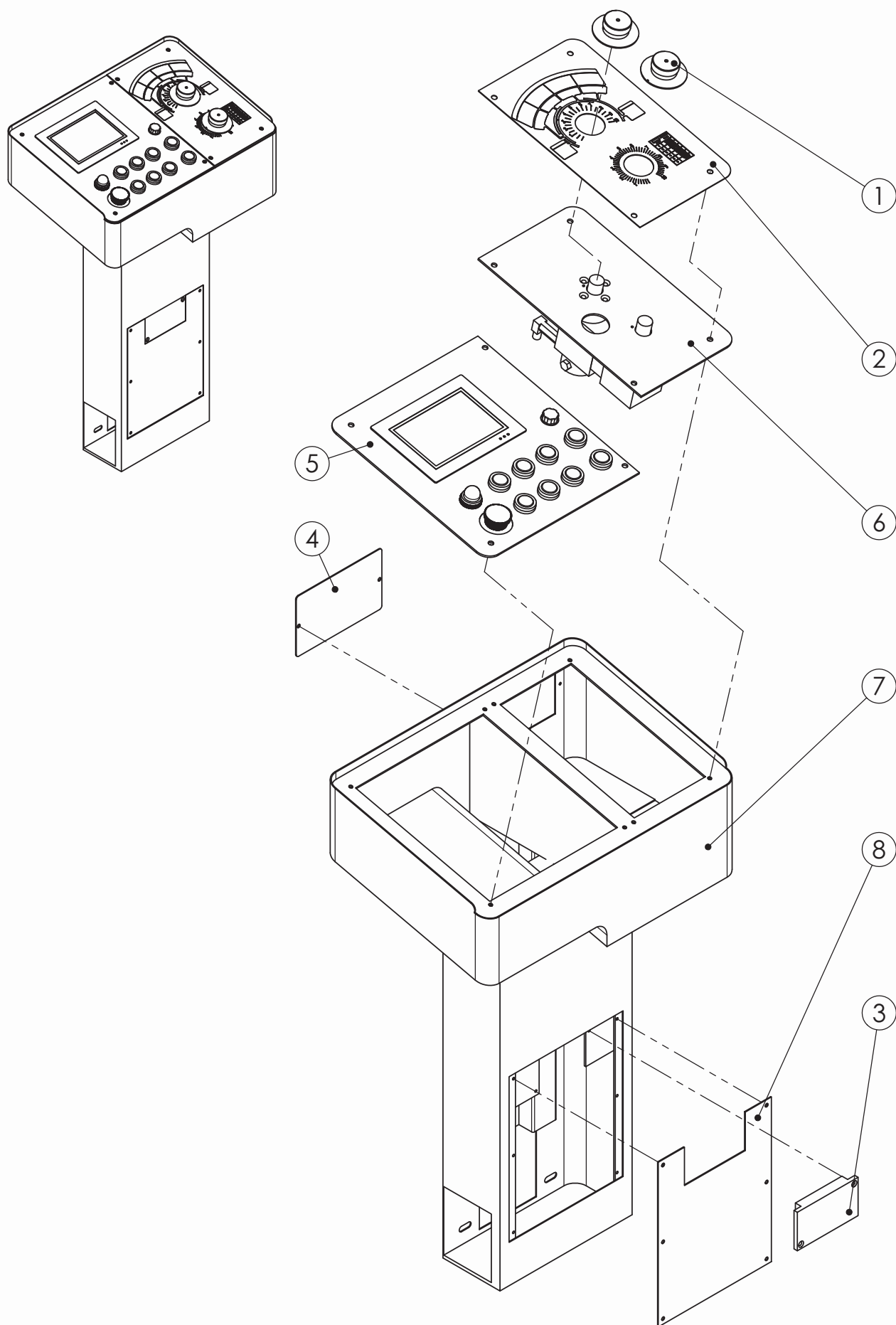



G320-EU168/AM55

20150209

操作箱組 Control Box Assembly

ITEM	PART NO.	PART NAME	PART NAME IN CHINESE	PART SPEC.	QTY
1	AHA-1806	Control knob	流量閥旋鈕		2
2	C250H-1325	Flow valve control panel	流量控制面板(AISI)		1
3	C320G-1072A	Reserved fixed seat	減壓閥預留固定座		1
4	C320G-1308A	Control box rear cover	操作箱後蓋		1
5	C320G-1321A	Control panel	控制面板板(5.7吋)(全行程)		1
6	C320G-1328A	Flow control base plate	流量控制底板		1
7	C320G-1337A	Control box	操作箱		1
8	C320G-1338A	Control box front cover	操作箱前蓋板		1

鋸弓組合圖

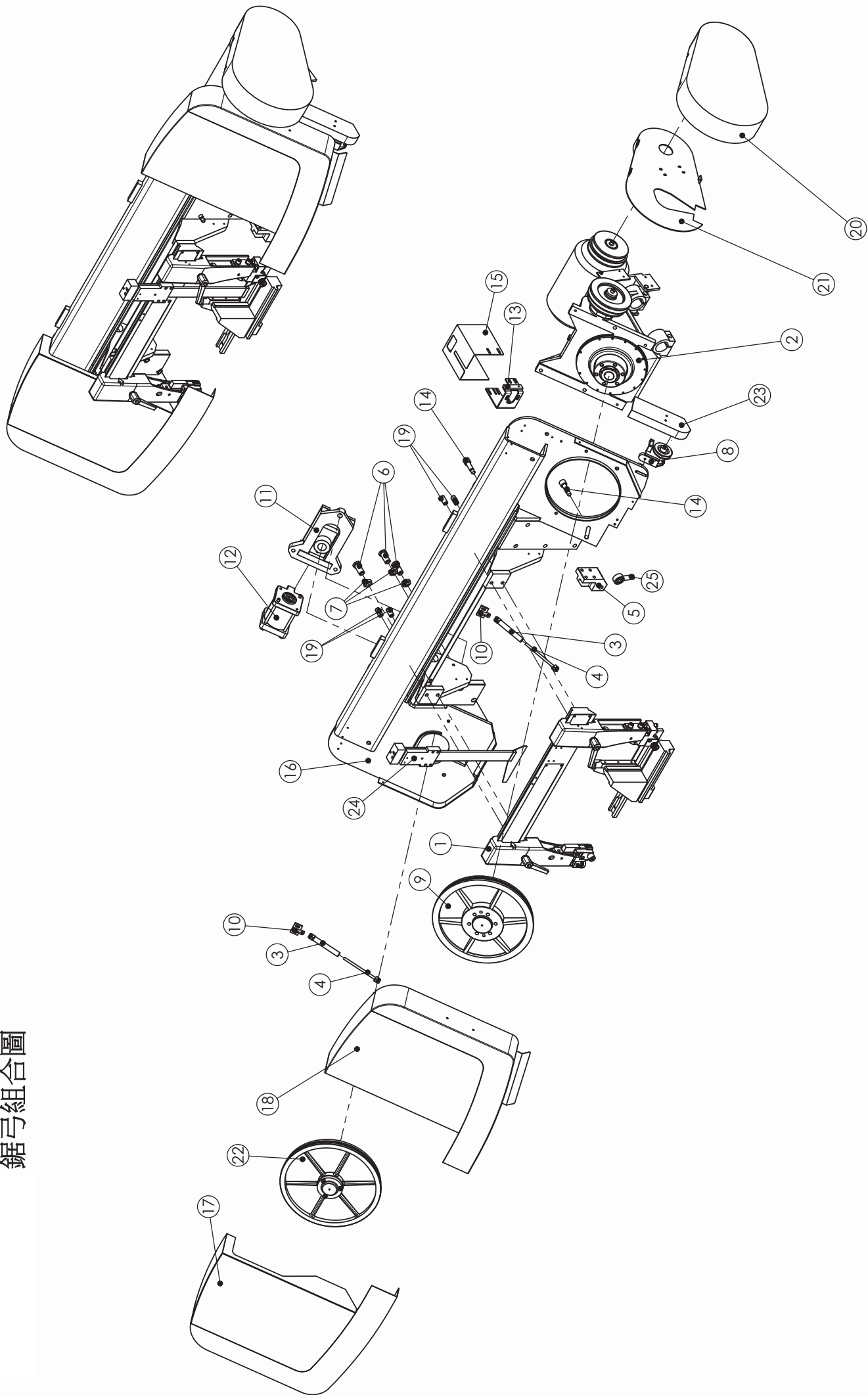

鋸弓組合圖 Saw Bow Assembly

ITEM	PART NO.	PART NAME	PART NAME IN CHINESE	PART SPEC.	QTY
1		Saw arm and sliding plate assembly	鋸臂滑板組		1
2		Gear reducer/motor assembly	減速機 / 馬達組		1
3		Nitrogen cylinder body	氮氣缸本體		2
4		Nitrogen cylinder shaft	氮氣缸心軸		2
5	AGC-3011	Saw bow cylinder ear	鋸弓油缸上耳		1
6	AHA-0610	Adjusting bolt	調整螺絲		3
7	AHA-0611	Adjusting nut	調整螺母		3
8	AHA-12110-1	Wire brush bearing seat assembly	鋼刷軸承座組		1
9	C250H-3041	Drive wheel	下輪		1
10	C250H-3460	Nitrogen cylinder fixed seat	氮氣缸固定座		2
11	C250H-33000	Tensioner sliding plate assembly	張力滑座滑板組		1
12	C250H-33200	Tensioner cylinder assembly	張力油壓缸組		1
13	C320G-1117A	Limit switch holder	限動開關固定座		1
14	C320G-1154	Fixed hex soc bolt	內六角固定螺栓		2
15	C320G-2104	Encoder cover	譯碼器護蓋		1
16	C320G-3001-2	Saw bow	鋸弓加工圖(一)		1
17	C320G-3003A	Idle wheel cover	上輪箱蓋		1
18	C320G-3005A	Drive wheel cover	下輪箱蓋		1

19	C320G-3021	Sliding plate adjusting bolt	滑板調整螺絲		4
20	C325H-3071	Pulley cover	普利護蓋		1
21	C325H-3073	Pulley cover base plate	普利護蓋底板		1
22	C320G-30300	Idle wheel assembly	上輪組		1
23	C325H-3237	Pulley cover	鋼刷普利護蓋		1
24	C325H-32000	Quick approach assembly	急降桿組		1
25	PP-14480	Connecting rod bearing	連桿軸承		1

鋸臂滑板組

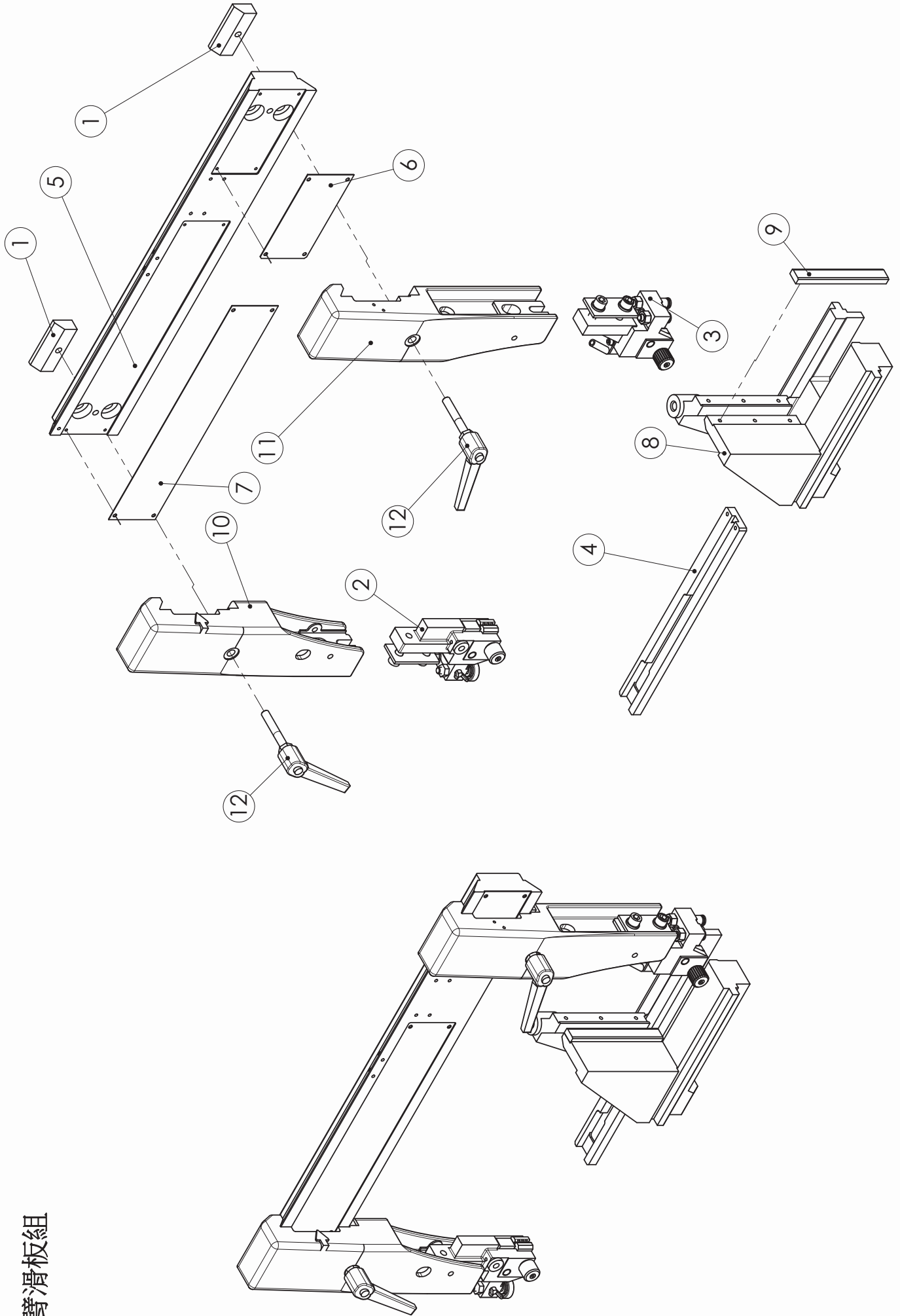

鋸臂滑板組 Saw Arm and Sliding Plate Assembly

ITEM	PART NO.	PART NAME	PART NAME IN CHINESE	PART SPEC.	QTY
1	AHA-0737	guide arm fixed block	鋸臂固定塊		2
2	C250H-31300	Left guide roller assembly	左導輪座組		1
3	C250H-31600	Right guide roller assembly	右導輪座組		1
4	C320G-2008-CE	Blade plate	前鋸線鋼板		1
5	C320G-3101	Guide arm sliding plate	鋸臂滑板		1
6	C320G-3111	Nameplate	右鋸臂銘牌		1
7	C320G-3112	Nameplate	左鋸臂滑板銘牌		1
8	C325H-2215	Front movable vise	前活動虎鉗		1
9	C325H-2241	Vise Plate	虎鉗鋼板		1
10	C325H-3103A	Left guide arm	左鋸臂		1
11	C325H-3105A	Right guide arm	右鋸臂		1
12	PP-52111E	Saw arm handle	鋸臂把手		2

C320G-42000 防震導輪組
C320G-42000 Vibration damper

C320G-42000防震導輪機構

ITEM	PART NO.	PART NAME	PART NAME IN CHINESE	PART SPEC.	QTY
1	C320G-4221	Vibration damper seat	防震座		1
2	C320G-4225	Spring holder	防震彈簧座		1
3	C510M-4231A	roller shaft	防震導輪軸		1
4	C460H-4206	Bearing washer	軸承墊圈		1
5	PP-14270B	Bearing	軸承		2
6	AHA-3301	Vibration damper roller	防震導輪		1
7	AGB-3308	Rubber ring	遮水橡皮		1
8	PP-14507	Bearing	軸心調承		1
9	PRD-8-50	Pin	平行銷		1
10	AGB-3307A	Grease cover	牛油擋		1
11	C320G-3397A	Vibration damper roller cover	防震導輪護蓋		1
12	C320G-3143A	Guide roller shaft	導輪軸		2
13	C320G-4222	Bearing washer	軸承墊圈		1
14	PUC-020	Grease nipple	油嘴	1/4"-28UNF	1
15	PP-57403	Spring	彈簧	TH-1625	1
16	C510M-3143	Guide roller shaft (2)	導輪軸(二)		1
17	PP-58111	Snap ring	扣環		2

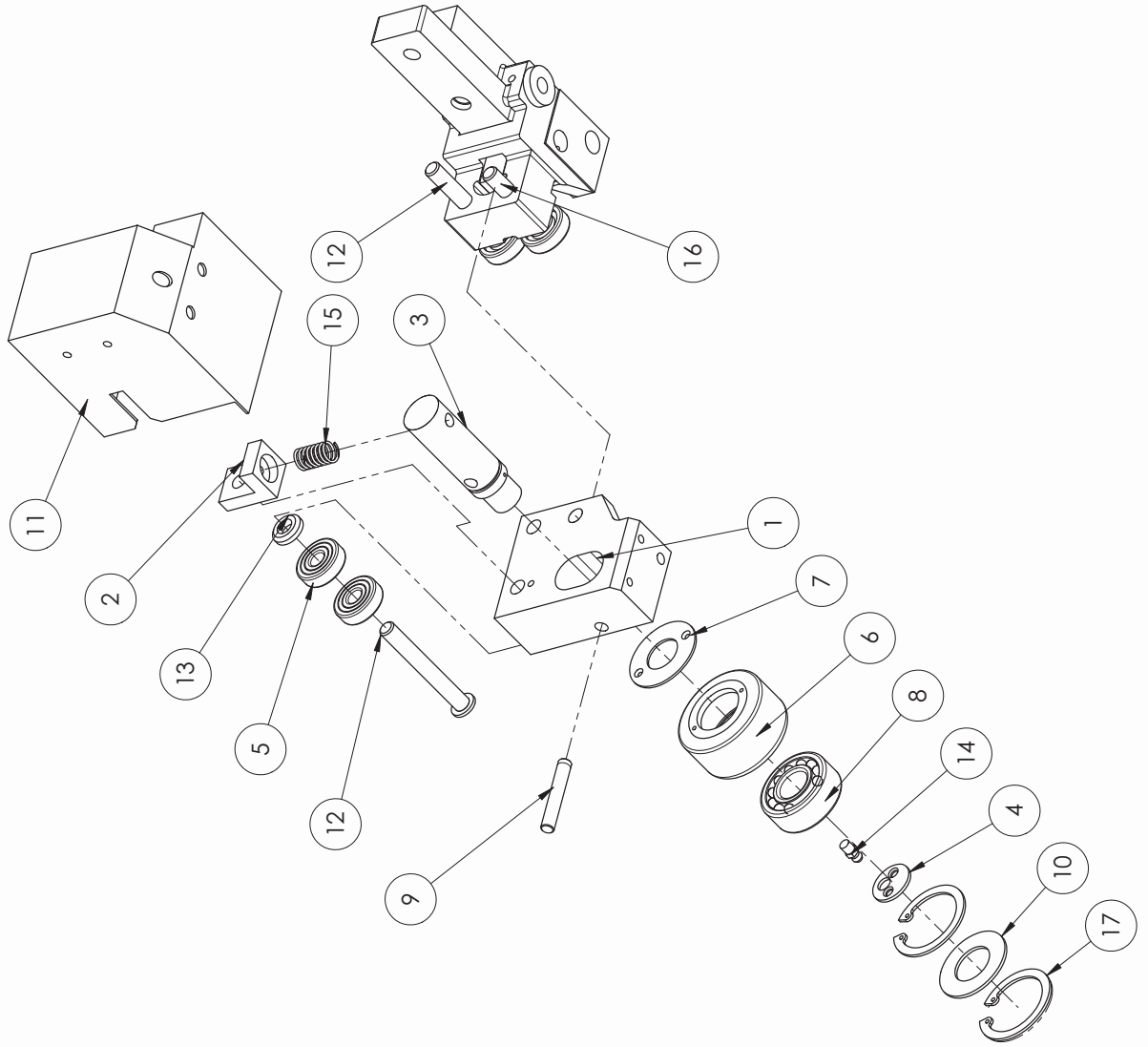

Warranty

Warranty

New machines are warranted to be free from defects in workmanship and material for a period of one (1) year from the date of shipment by Seller. The warranty period is based on normal usage of two thousand eighty hours (2080) per year and is reduced proportionately for any excess usage. Products, which under normal operating conditions in Buyer's plant are defective in workmanship or material, will be repaired or replaced at the option of Seller.

This warranty does not cover shipping freight charges for either the return of the defective part or for the shipping of the replacement or repaired part.

Seller will have no obligation to repair or replace perishable parts, or materials or parts damaged by misuse, negligence or failure of Buyer to provide appropriate maintenance and service as stated in the operator's manual or industry standard and normally acceptable practices.

This warranty does not apply if the machine has been altered or modified without our prior written consent.

In the case of components or units purchased by Seller including work holding devices, tool holders, motors and controls, the warranty shall not exceed that received by Seller from the supplier of such components or units.

Seller will not assume responsibility for products or components returned to Seller without prior consent or for unauthorized repairs to its products, even though defective.

Electrical Equipment: The warranty available for all electrical components to the Buyer will be voided if the voltage supplied to the machine is found to be outside the stated voltage of the machine by +/- 10% and/or grounded at machine.

Accessories Supplied with Manufacturer's Equipment: The warranties available to the Buyer are those extended by the accessory manufacturer, if any, to the extent they are in force and effect. The ACCESSORY MANUFACTURER'S WARRANTY, if any, is exclusive and is in lieu of all other warranties whether written, oral or implied.



Vertical Plate Saws
Horizontal Billet Saws
NC/CNC Band Saws
Structural Miter-Cutting Saws
Automatic Band Saws

Visit our website at
www.cosen.com

COSEN MECHATRONICS CO., LTD.