

Ironwood P500

User Manual

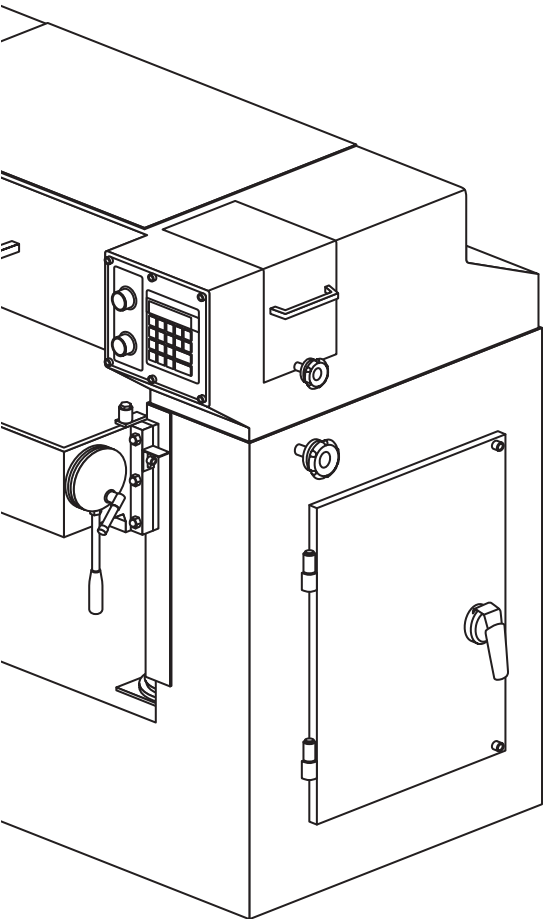

general information. features.

technical specifications. safety considerations.

delivery and installation. inspection.

remove machine from pallet. level.

safety. **operation and adjustments.**

machine controls. machine operation.

tool adjustments. troubleshooting.

electrical print. **maintenance.**

periodic maintenance. **safety.**

IRONWOOD

stiles

Table of Contents

1.0	General Information.....	3
1.1	Thank You!	
1.2	Before Contacting Stiles	
1.3	Features	
1.4	Intended Use	
1.5	Technical Specifications	
1.6	Safety Considerations	
2.0	Facility Preparation.....	6
2.1	Floor	
2.2	Work Space	
2.3	Power	
3.0	Delivery and Installation ...	7
3.1	Receiving Your Machine	
3.2	Unpack the Machine	
3.3	Inspection	
3.4	Move Machine to Final Position	
3.5	Remove Machine from Pallet	
3.6	Level	
3.7	Pre-Operation Cleaning	
4.0	Connect to Power.....	11
5.0	Safety.....	12
6.0	Operation and Adjustments	13
6.1	Machine Controls	
6.2	Machine Operation	
6.3	Tool Adjustments	
7.0	Maintenance.....	19
7.1	Lubrication	
7.2	Inspection	
7.3	Periodic Maintenance	
8.0	Troubleshooting	20
8.1	Electrical Print	

 **PLEASE REVIEW AND OBSERVE ALL SAFETY INFORMATION / DIRECTIVES BEFORE INSTALLING, OPERATING, OR PERFORMING MAINTENANCE ON THIS MACHINERY.**

1.0 General Information

1.1 Thank You!

Thank you for your purchase of the Ironwood P500 Planer. At Stiles Machinery, our goal is to ensure that you are fully satisfied with your purchase. This manual is provided so that you may properly assemble, operate, and maintain your P500. Should you need help, our team of dedicated service personnel are available to answer your questions and provide any resource recommendations you may need.

Warranty and Support

All Ironwood machines are designed to meet the exacting standards demanded by craftsmen like you. Ironwood machines include a one (1) year parts warranty and two (2) years of free 24/7 technical support beginning at date of shipment. Standard technical support remains in effect for free for the lifetime of the machine thereafter. Warranty service work is not covered by manufacturer's warranty. Stiles' service team is available for an additional charge.

1.2 Before Contacting Stiles

Please have your machine model and serial number available when contacting Stiles Machinery with questions. The machine's model and serial number are listed on the metallic plate located on the machine's frame.

For specific information regarding the electrical system and pneumatic supply, please refer to the data that is stamped on the metallic plate.

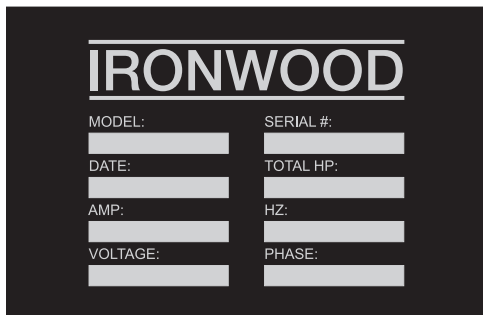

Machine information plate

Stiles Technical Support
616.698.6615

Stiles Parts
800.PARTS.80 (800.727.8780)

Website
www.stilesmachinery.com/ironwood/p500

Machine Model _____

Machine Serial Number _____

1.3 Features

- Iron machine base
- Four heavy-duty jack screws enable precise and vibration-free performance
- Cast iron table is heat treated and precision ground for rigidity and stability
- Conveniently located controls
- Segmented infeed roller and pressure shoe ensure positive contact on workpieces of varying thickness
- Spiral cutterhead has six rows of 13 carbide inserts, providing high chip-removal rate, superior surface finishing, and reduced noise levels
- 1/4-hp motor raises and lowers table
- 1-hp feed motor with variable speed controls
- Variable feed speeds from 19-39 feet per minute
- Heavy-duty 7.5-hp cutterhead motor
- Enclosed micro-adjustment dial for accurate positioning of the table
- Bed roller for planing of rough or finished lumber or glued panels adjusts quickly from 0.0-0.5"

1.4 Intended Use

The Ironwood P500 is designed for planing raw stock to achieve a desired thickness and/or remove defects. Planing typically follows jointing (flattening and straightening) in the woodworking process.

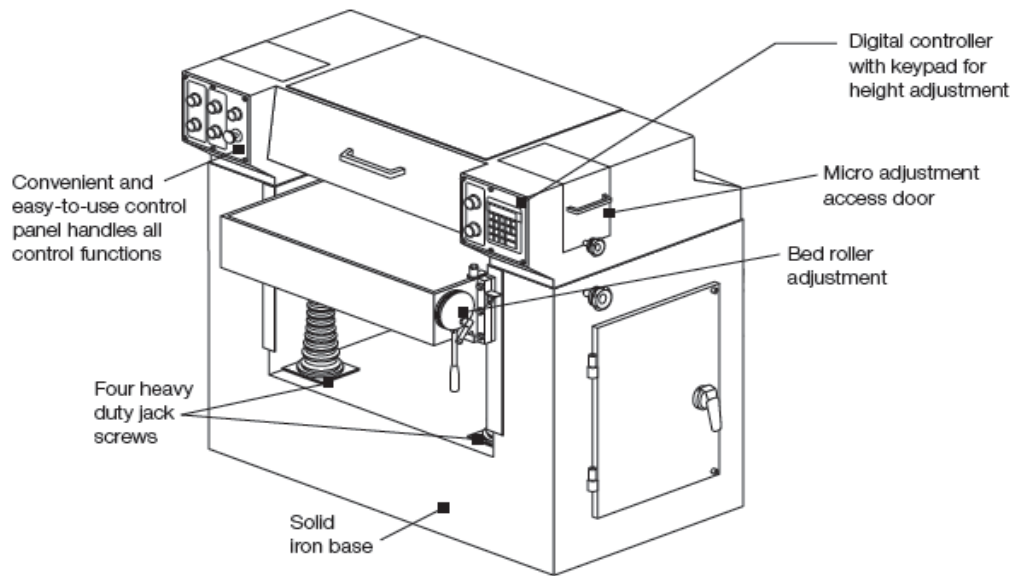

1.5 Technical Specifications

Description	Ironwood P500
Work-Table Size	22" x 29½" (560mm x 750mm)
Table Height	46¾" (1180mm)
Machine Size	29½" x 48" (750mm x 870mm)
Max Width of Workpiece	20" (508mm)
Max Thickness of Workpiece	11¾" (300mm)
Min Thickness of Workpiece	¾" (10mm)
Max Cutting Depth	⅝" (8mm)*
Min Length of Workpiece	8⅝" (220mm)
Cutterhead	Helical
Cutterhead Diameter	3⅞" (100mm)
Number of Knives	75
Cutterhead Motor	7.5 hp
Cutterhead Speed	4,800 rpm
Infeed Roller	(1) 3" (76mm) segmented infeed roller
Outfeed Rollers	(2) 2⅞" (60mm) rollers
Table Rollers	(2) 2⅜" (55mm) rollers
Table Adjustment	Motorized
Table Position Display	Analog with mechanical digital readout
Electrical	230v / 460v (3 phase)
Amperage	23.1 amps @230v / 11.3 @ 460v
Dust Port Diameter	6" (150mm)
Dust Extraction Requirements	800 cfm @ 4,500 feet/min.
Shipping Dimensions (W x L x H)	34" x 49" x 52" (863mm x 1244mm x 1320mm)
Shipping Weight	1800 lbs. (815 kg)

* Maximum cutting depth is determined by wood characteristics

1.6 Safety Considerations

For your safety, read these instructions thoroughly before you install and operate this machine. Always have these instructions available at the machine for reference.

Observe all codes and regulations that apply to the installation and operation of this machine.

Keep visitors at a safe distance from the work space.

Keep children away from this and all machines. Childproof your work area!

Familiarize yourself with the safety notices used in this manual.

CAUTION

If cautions are ignored, personal injury and/or machine damage may result.

WARNING

Never use the P500 for purposes other than its intended use. Do not modify or remove any guards or other safety features. Improper use or modifications may affect your warranty or result in serious injury or death.

Training

This machine is intended for use by authorized, well-trained operators only.

Do not operate until you have a complete working knowledge of the machine and have been properly trained for its safe operation, correct adjustment, and use. All operators should thoroughly read and understand this manual and the workings of this machine prior to operation.

It is essential that all operators be aware of the following:

- The dangers associated with the operation of this machine.
- The use of personal protective equipment for ear and eye protection.
- The proper positioning of the operator and operator's hands relative to the cutterhead.
- The principles of machine operation.
- The safe handling of the workpiece when planing.
- The safe stacking of the workpiece before and after planing.

2.0 Facility Preparation

Prior to uncrating your machine confirm that your location can accommodate the Ironwood P600. Follow these guidelines:

2.1 Floor

- The floor must be flat and level.
- Although no special foundations are required, a concrete floor is recommended.
- All floors must have a load-bearing strength suitable for the machine weight of approximately 2,100 pounds (959 kg).
- If anchoring the machine to the floor, purchase high quality anchor bolts appropriate to the floor construction and material.

2.2 Work Space

- Provide adequate work space surrounding the machine.
- Provide proper non-glare, overhead lighting.
- Place the machine so that any potential kickback area is not in line with aisles, doorways, or other work and traffic areas.
- Provide adequate dust extraction system.
The dust extraction system should have a flow of 4,500 feet per minute at 800 cfm.

Standard machine clearance requirements

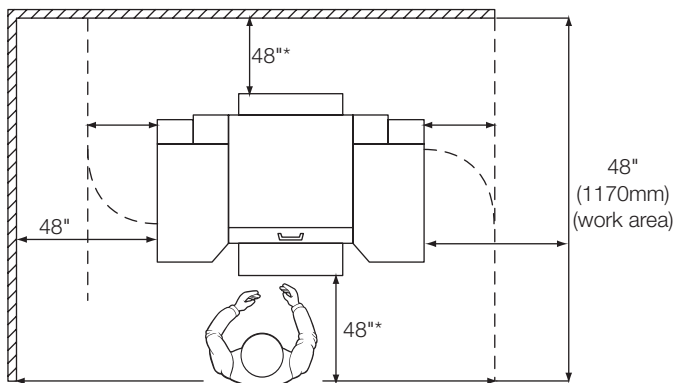

Machine clearance requirements*

*Actual clearance requirements may vary depending on length of material to be cut.

2.3 Power

⚠ WARNING

A licensed electrician must connect the P500 to the building power source.

- Do not use extension cords.
- Be sure that the electrical voltage of the power source is of the same characteristics as the electrical system supplied with your machine. If other machine voltage capabilities are required, contact Stiles Machinery.

	P500
Planer Motor	7.5 HP
Feed Motor	1 HP
Table Lift Motor	1/2 HP
Power	230v / 460v (3 phase)
Total Required Amperage	23.1 amps / 11.3 amps

- Ensure the machine is protected with an external over-current protective device per your local electrical codes.
- Electrical equipment operating conditions:
Air temperatures between +41°F (+5°C) and +113°F (+45°C).
Relative humidity not to exceed 50% at a maximum temperature of +113°F (+45°C).
- Electrical equipment is designed and protected to withstand the effects of transportation and storage temperatures within a range of -13°F (-25°C) to +131°F (+55°C), and for short periods of time not exceeding 24 hours at up to +158°F (+70°C).
- Ensure connection to factory ground system is wired correctly (according to IAW local electrical codes and NEC) and not connected to any electromagnetic interference source such as welders.

3.0 Delivery and Installation

3.1 Receiving Your Machine

You will be contacted to arrange delivery. Your machine will be delivered by truck to your location. If there is no loading dock, be sure that you have informed the carrier in advance so that they deliver using a truck with a lift gate to lower the machine to ground level.

Before accepting the machine and signing the bill of lading from the carrier, please inspect crating and machine condition, note potential damage on the bill of lading, take pictures of potential damage, and contact Stiles Machinery immediately at 616.698.7500.

The machine will arrive fully crated and secured to a pallet. Use a hand truck or fork lift to move the machine on its pallet as close to its final position as possible.

If you do not intend to install the machine immediately after delivery, store it in a protected, cool, and dry location.

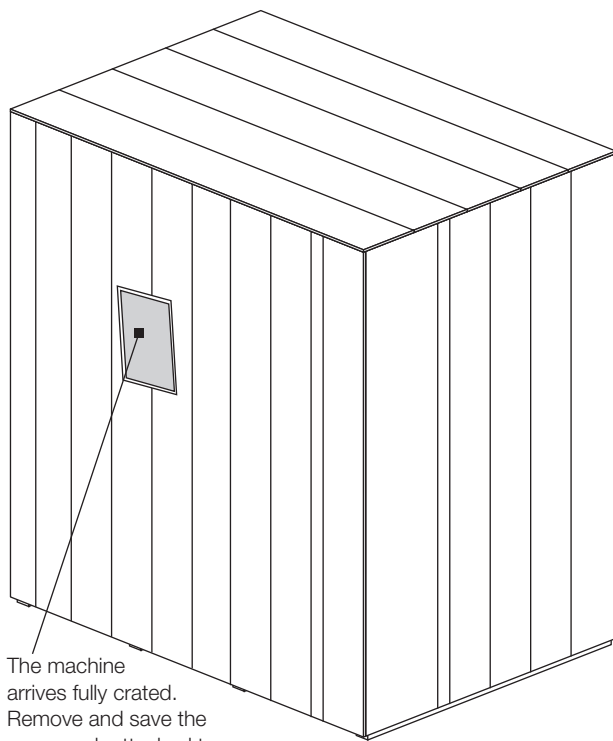

The machine arrives fully crated. Remove and save the paperwork attached to the outside.

3.2 Unpack the Machine

TOOLS REQUIRED:

- Hammer
- Crowbar

Unpack as follows:

Do not remove the machine from the pallet.

1. Remove and save all paperwork attached to the outside of the crate.
2. Remove the crating, starting with the top, then remove the four sides. Use caution to avoid personal injury and prevent damage to the machine's finish.
3. Remove the protective plastic from the machine, starting at the bottom.

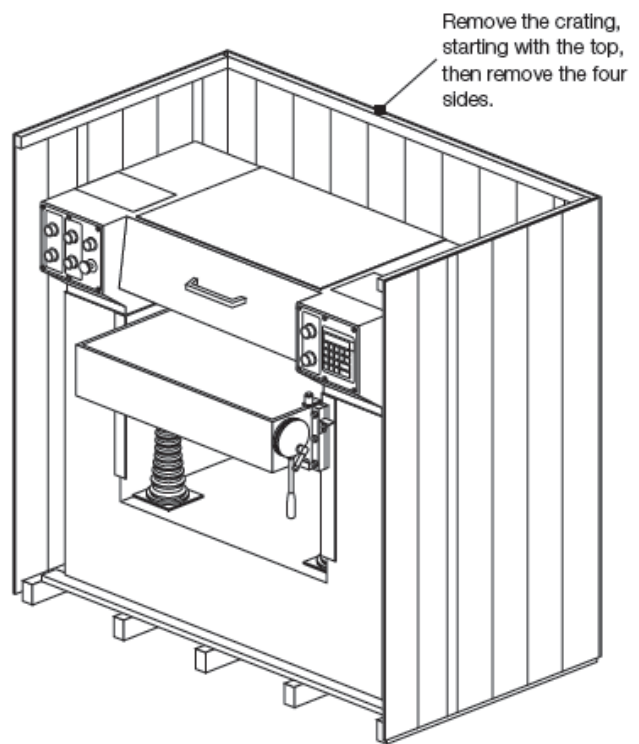

Remove the crating, starting with the top, then remove the four sides.

4. Remove the plastic sleeve from the side access door handle. A second access door is located on the opposite side. The door is locked when the handle is in the vertical position. Turn the handle to the right to unlock and open the access door.

5. Check inside the access doors for any hardware or accessories. Remove the hardware, accessories, and a tool kit that may be shipped inside the machine. If additional accessories are ordered, they may be delivered separately.

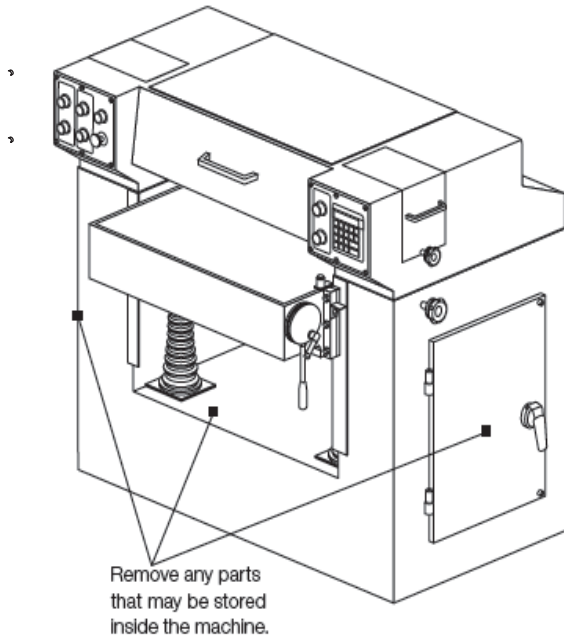

6. Ensure all rotating components turn by hand.
7. Close and lock the side access door.

3.3 Inspection

Save all containers and packing materials until you are satisfied that your machine has arrived in good condition. If you discover the machine is damaged after you've signed for delivery, immediately call Stiles Customer Service at 616.698.7500.

When you are completely satisfied with the condition of your equipment, you should inventory its parts.

Open and check the contents of all containers to ensure all tools, hardware, and accessories are included. The tool kit should contain the following items:

1. 3-piece open end wrench set
2. 4mm, 5mm, 6mm and 8mm short handle Allen wrenches
3. 5mm long handle Allen wrench
4. Handle key for locking/unlocking side access doors
5. Two (2) 5mm T-handle Allen wrenches
6. Five (5) extra carbide inserts (30 x 12 x 1.5mm)
7. Five (5) extra gibs for cutterhead
8. Five (5) extra nuts for cutterhead
9. Five (5) extra set screws for cutterhead
10. Four (4) leveling pads
11. Four (4) leveling bolts with nut
12. Touch-up paint (2 color set)
13. User manual

3.4 Move Machine to Final Position

Be sure the site is properly prepared. Refer to section 2.0 for details.

Be sure the cabinet doors are closed and locked before transporting.

TOOLS REQUIRED:

- Hand truck or fork lift

Use a hand truck or fork lift to move the machine on its pallet to its final location. If using a fork lift, make sure fork travel is clear of any obstacles.

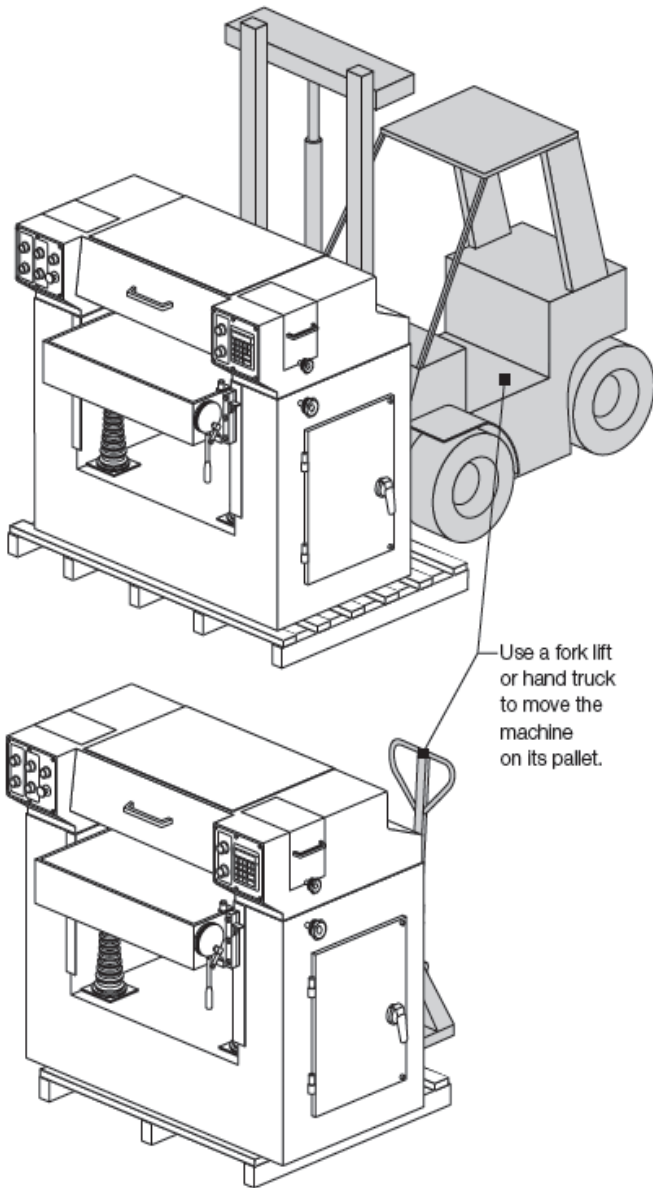

3.5 Remove Machine from Pallet

CAUTION

The P500 weighs approximately 1,800 pounds (815kg). For this procedure, we recommend using a fork lift.

TOOLS REQUIRED:

- Adjustable wrench
- Machine-door key

When the machine has been placed at its final location, carefully remove the machine from the pallet.

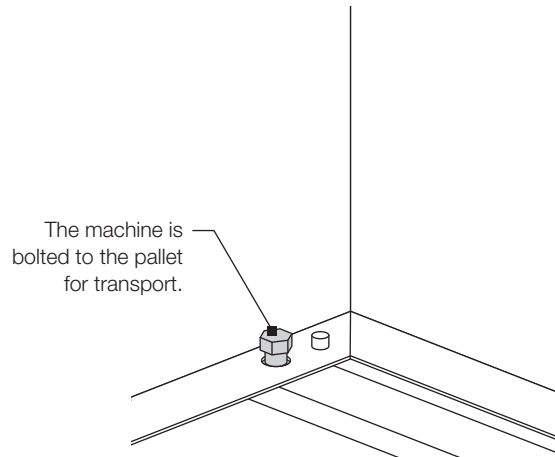

1. From inside the cabinet, remove the four bolts that secure the machine to the pallet at the interior corners.
2. Lift the machine from the pallet by one of 2 methods:
 - a. Slide machine onto forks of fork lift.
 - b. With a fork lift or crane, use a hoist hook and lift strap secured to the hooks on the side of the machine to move and place the machine.
3. Carefully slide or set the machine into final position.

If vibration moves the machine from its position during operation, mount the machine to the floor. Purchase high quality anchor bolts appropriate to the floor construction, and anchor through the mounting holes on the base. After anchoring the machine to the floor, recheck the machine to make sure it is level and adjust anchors and leveling bolts if necessary.

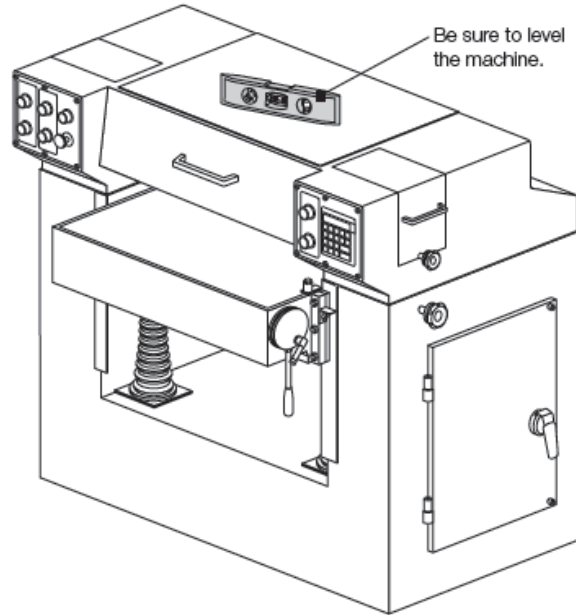
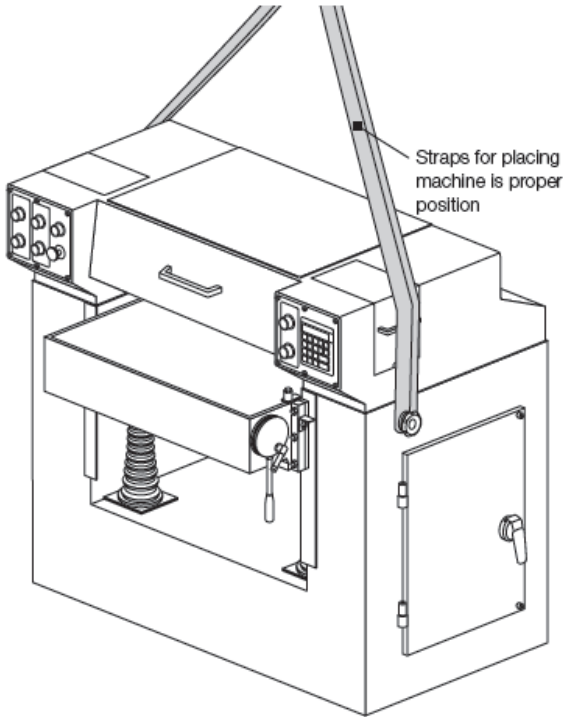

3.6 Level

TOOLS REQUIRED:

- Bubble Level
- Adjustable wrench

Use a bubble level along the length and width of the tabletop surface to check for level. Use an adjustable wrench to adjust leveling bolts to level the machine.

3.7 Pre-Operation Cleaning

⚠ WARNING

Use proper cleaning agents and methods described below. Do not use gasoline or other petroleum-based solvents. There is a risk of explosion and burning if these products are used. Serious personal injury may occur.

Machine Tabletop Surface

Remove and discard any projective materials from the top of the machine. Remove the rust-preventative oil that coats the machine using a soft cloth and nonflammable degreasing agent, such as Simple Green or other citrus-based cleaners. Do not use abrasive pads.

Table Rollers, Feed Rollers, and Cutterhead

⚠ CAUTION

Use extreme care when cleaning or working with the cutterhead. The knives are very sharp.

4.0 Connect to Power

- Voltage – Steady state voltage +/- 10% of nominal voltage.
- Machine needs steady voltage at all times.

WARNING

Before connecting power to the machine, make sure all screws and fasteners are tightened, all mechanical functions work freely, and the cutterhead and rollers turn freely.

WARNING

All connections to electrical power should be completed by a licensed electrician.

Before connecting to a power source, confirm that the electrical current of the power source is the same as the electrical system supplied with your machine. Ensure the machine is protected with an external over current protective device per your local regulating authorities.

Machine must be properly grounded to prevent electric shock. Never connect the yellow/green wire to a live terminal.

Once connected to power source, terminals are electrified even while the power switch is off.

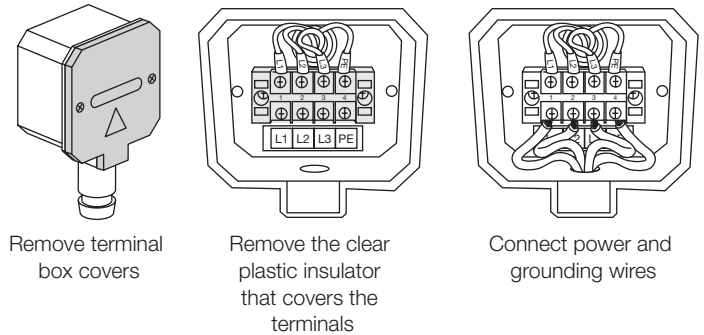
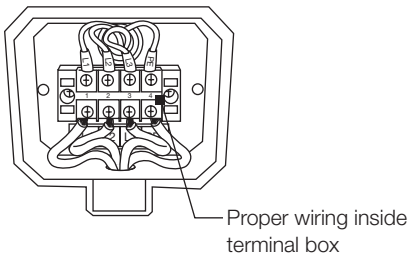

WARNING

Always shut off power at source before removing terminal box cover. Failure to comply with this action may result in electric shock.

CAUTION

We have covered some basic electrical requirements for the safe installation of your machine. These requirements may not cover all installation requirements. You must confirm that your particular electrical configuration complies with all local codes. Ensure compliance by checking with your local municipality and a licensed electrician.

To connect source power to the machine:

1. Remove two screws and remove terminal box cover.
2. Remove clear plastic insulator that covers the terminals.
3. Insert source power cables through opening of terminal box.
4. Connect the three power cables to terminals L1, L2 and L3, and the yellow/green ground wire to ground terminal.
5. Replace clear plastic insulator and power box cover.

5.0 Safety

WARNING

Like all power equipment, there is danger associated with the Ironwood P500. Use caution and follow all safety instructions. Take every precaution to protect yourself, others around you, and the machine itself from improper use. Safety is a combination of common sense, training, and being alert at all times while operating your machine. If instructions, warnings, and cautions are not followed, serious personal injury or death may occur.

EYE PROTECTION: Always wear approved safety glasses, or a face shield when operating this machine. Only use eye protection that meets or exceeds the standards of the American National Standards Institute (ANSI).

EAR PROTECTION: Always wear ear protection during machine operation.

DRESS CODE: Do not wear loose clothing, neckties, jewelry, or gloves that can get caught in moving parts. Confine long hair and keep sleeves above the elbow.

ELECTRICAL GROUNDING: Your machine must be electrically grounded. If a cord and plug are used, make certain the machine is properly grounded. Follow the grounding procedure indicated by the National Electric Code and local regulating authorities. Keep power tools in dry areas and free from moisture.

GUARDS: Make certain that machine guards are in place and in good working order. Do not operate the machine if guards are not in place.

TOOLING AND ACCESSORIES: Use only recommended tooling and accessories. Improper tooling and accessories may cause damage to your machine or personal injury. Always run at the correct speed and feed rate. Never force a tool or accessory to perform a job for which it was not designed. Maintain your tools and accessories. Knives should be sharp and clean for safe and optimal performance. Follow instructions for lubricating and changing tooling and accessories.

POWER: On machines equipped with a manual starter, make sure that the main on/off switch is in the "OFF" position before connecting power to the machine.

Make certain the machine is either unplugged or electrically disconnected and locked out when performing all maintenance, cleaning, or machine adjustments. Never leave the machine running unattended. Always turn the power off and stay by the machine until the cutterhead comes to a complete stop.

HOUSEKEEPING: Before turning machine on, remove all extra items on or around the machine. Keep the work area clean and free of scrap material, sawdust and other debris to minimize the danger of slipping. Use compressed air or a brush to remove chips or debris. NEVER use your hands.

6.0 Operation and Adjustments

6.1 Machine Controls

Push-button controls are conveniently located on the front of the machine. A feed speed control is located on the upper left-side panel. Familiarize yourself with the controls before operating the machine.

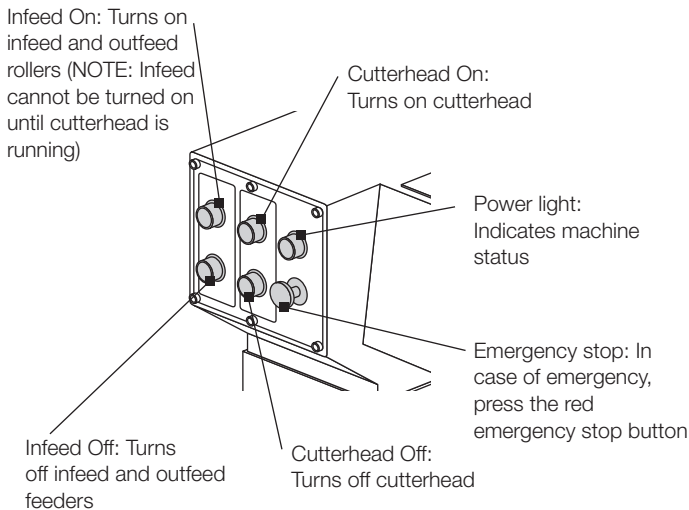

6.2 Machine Operation

Prior to machine set-up or performing any adjustments, repair work, or trouble shooting, it is very important to check the applicable safety functions to ensure they are all in proper working condition.

To operate and adjust the machine, follow these steps.

⚠ WARNING

Disconnect the machine from its power source.

Step 1: Check the Cutterhead

⚠ WARNING

The planing knives in the cutterhead are very sharp. Handle with extreme care when cleaning, sharpening, or replacing.

The spiral cutterhead is equipped with a set of 75 carbide inserts that house the planing knives.

The cutterhead should be inspected before each operation. Be sure the carbide inserts are secure and not fractured or chipped in any place. Loose or damaged inserts may be thrown from the machine and pose extreme danger. If knives are damaged or missing, they should be replaced immediately to maintain cutterhead balance.

Also check the knives for sharpness. The knives are two sided and can be rotated when dull. Once both sides of a knife are dull, the carbide inserts should be replaced. To obtain replacements, call Stiles Parts Dept. at 1-800-727-8780. Reference part # 56-010-12005.

To remove and replace inserts, proceed as follows:

1. Loosen the knife gib by turning the Allen head screw into the gib.
2. Remove the gib and knife.
3. Remove the remaining knives in the same manner.
4. Thoroughly clean the knife slots and knife gibs.
5. Check the screws. If they appear worn or stripped, replace them.
6. In sequence, insert the knife and knife gib into the slot of the cutterhead.
7. Fasten the knife and gib with spacer and Allen head screw.
8. Repeat process until all knives are set in position and tight.

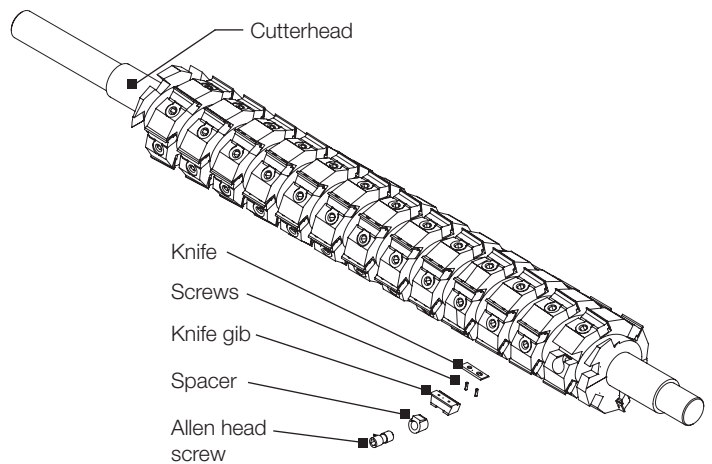

Step 2: Machine Alignment

NOTE: The P500 comes pre-aligned from the factory. Do not adjust unless you are experiencing cutting issues. Call Stiles Machinery Technical Support at 616.698.6615 prior to attempting any machine adjustments.

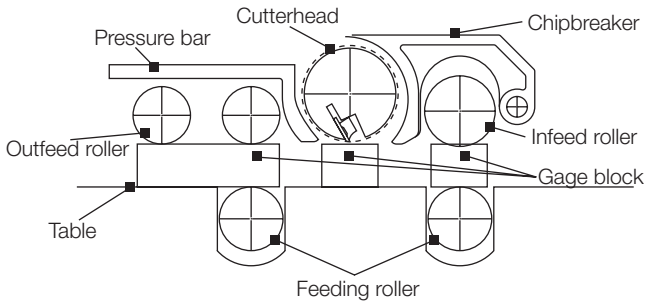

Rollers and chipbreakers should be positioned in proper relation to the cutterhead. Use a dial indicator if necessary to check positions and make proper adjustments.

1. The cutterhead is used as the zero line reference on the dial indicator.
2. Move the dial indicator to the segmented infeed roller. The roller should be 1.0mm below the cutterhead. To adjust, loosen lock nut and turn the adjustment bolt located at the position listed below.

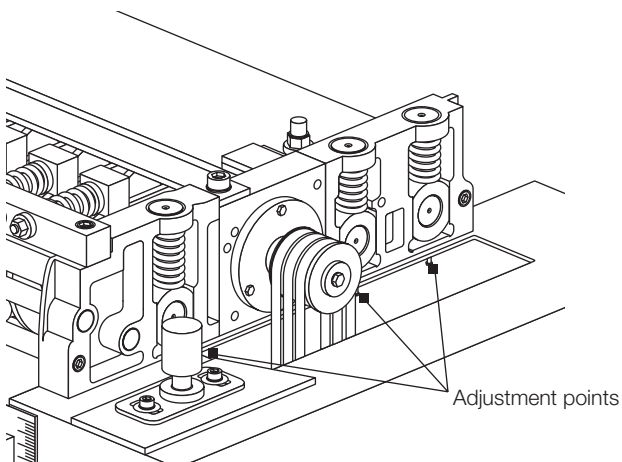
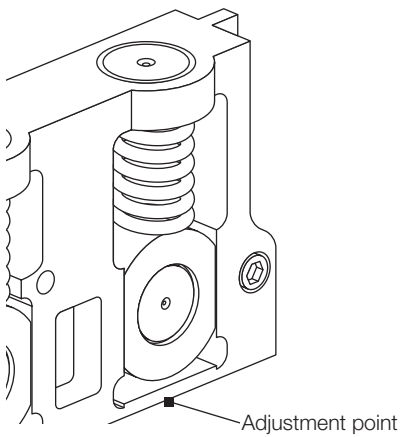

3. Move the dial indicator under each segment of the front chipbreaker. Each segment should be 0.5mm below the cutterhead. To adjust, turn the bolt that presses against each spring until the chipbreaker is 0.5mm below the cutterhead.
4. Move the dial indicator to the rear chipbreaker. The bar should be even with the cutterhead. To adjust, turn the two rear screws in the back of the machine.
5. Move the dial indicator to the outfeed rollers. Each roller should be 0.7mm below the cutterhead. To adjust, loosen lock nut A and turn bolt B.

Step 3: Adjust Table Rollers

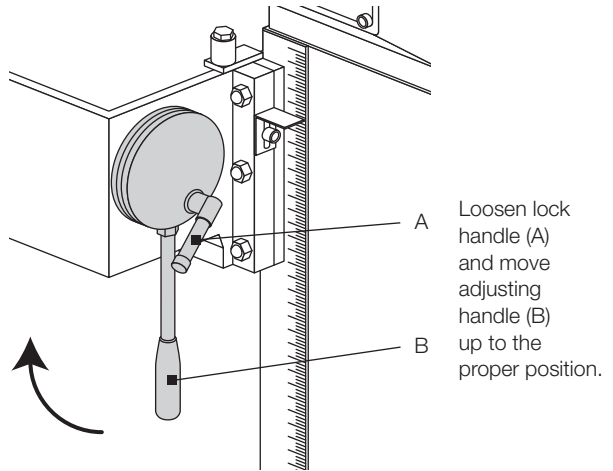
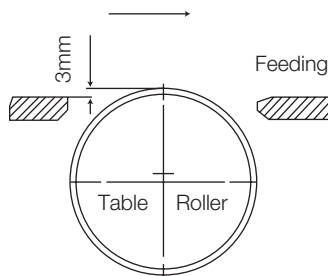

Table rollers are adjusted to the proper height using the quick-set handle mounted on the right side of the work table. As a general rule, when planing rough stock, table rollers should be set at a high position; when planing smooth stock, table rollers should be set at a low position. Normal height is set 0.1mm above the main table.

NOTE: Table rollers must always be set parallel to the work table. The maximum roller adjustment is 0.125"/3mm.



Step 4: Check Spring Tension of Infeed and Outfeed Rollers

Over time, the roller spring tension may decrease. To adjust the spring tension, turn the spring tension adjustment screw.

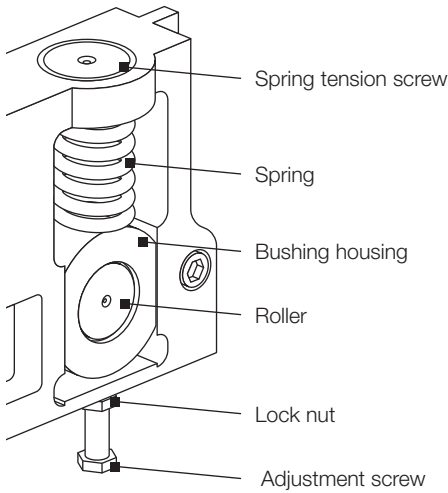

Step 5: Check Belt and Chain Tension

Maintain proper v-belt tension to the cutterhead. New belts must be checked weekly for the first 3 months of operation until they are stretched.

Increase v-belt tension by lowering the adjustment bracket.

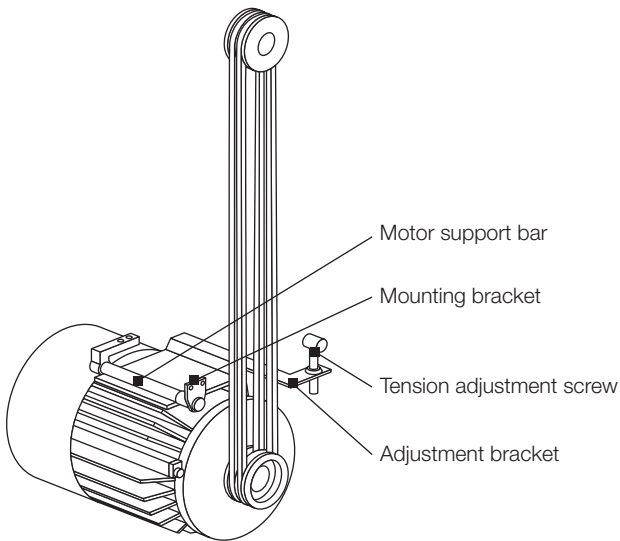

When the feed drive belt becomes loose, adjust the tension adjustment screw.

CAUTION

Never place the v-belt under excessive strain, as this can overload the motor and damage the bearings, cutterhead, or belt.

Step 6: Turn on the Machine

WARNING

Do not operate this machine with the safety guard(s) removed.

WARNING

Before starting the machine, inspect it to ensure it is free of all debris.

WARNING

Never start the machine with the workpiece in contact with the cutterhead.

Connect the machine to the power source. Turn on the red main on/off switch on the control panel.

Step 7: Table Height Adjustment

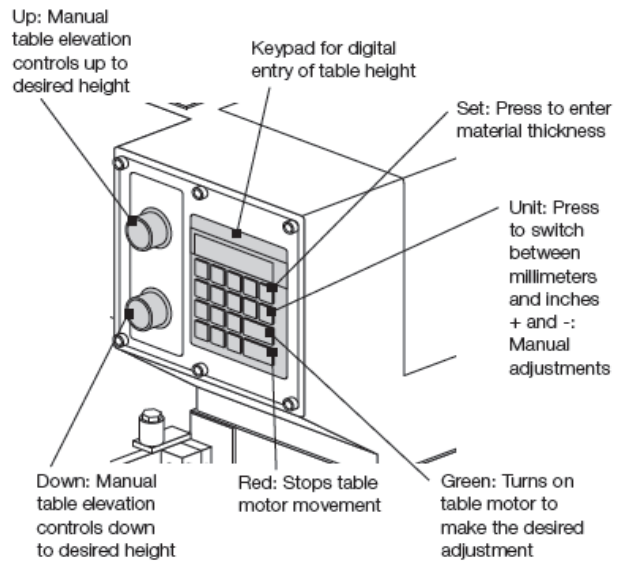

To set material thickness, use the keypad entry. The digital display displays increments of 001".

The work table is mounted on the machine frame. The desired depth of cut is achieved by adjusting the table height. The table raises and lowers on four jack screws mounted on thrust bearings.

This planer is equipped with easy-to-read digital thickness display. There is also a thickness scale to the right of the table.

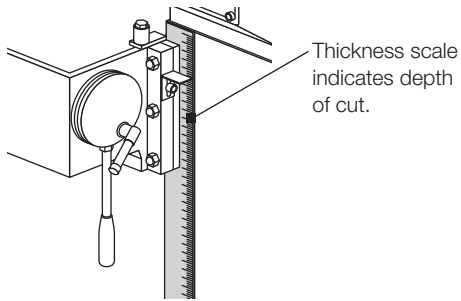

To set the table height, use the buttons on the front of the machine, as follows:

1. Press the up or down button to bring the table up or down.
2. To fine-tune material thickness, turn the micro-adjustment control knob located under the lift cover on the top right side of the machine.

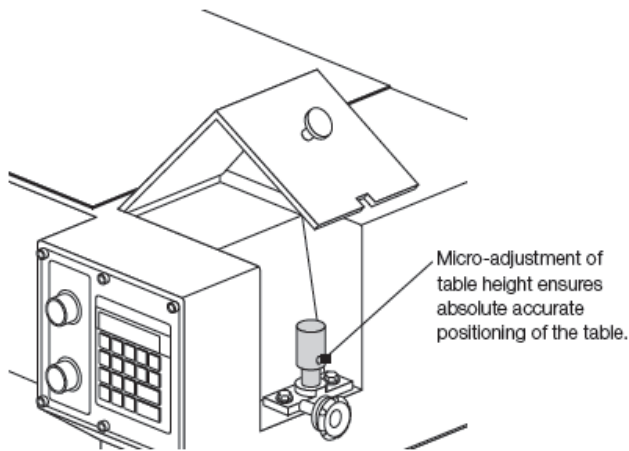

Change Table Height

To move the table up or down, press the Up or Down button (or +/- buttons on the keypad) on the control panel.

Table Height Limits

A limit switch defines how far the table will raise or lower. When a limit switch stop on the table comes in contact with a limit switch, the table motor switches off to prevent damage in maximum high and low positions.

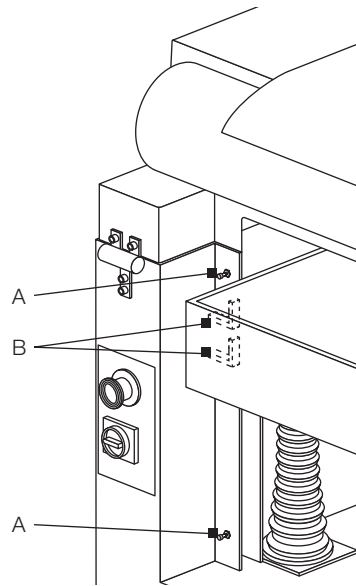

Limit switches (A) turn off the table motor when contacted by the switch blocks (B).

Step 8: Turn Cutterhead On

Press the green Cutterhead On button to start the cutterhead.

Step 9: Turn Infeed On

Press the green Infeed On button to start the infeed.

Step 10: Set Feed Speed Control

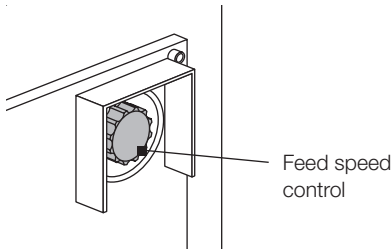

Controls the rate of feed through the planer, measured in feet per minute.

CAUTION

Only make feed speed adjustments with the Infeed roller on. If feed speed adjustment is changed while infeed is not running, damage will occur to the speed adjustment device.

The P500 is equipped with a 1 hp feed motor and variable feed speed control system.

Turn the feed speed adjustment knob to control the speed.

Set the feed rate between 19 feet per minute (fpm) to 39 fpm to meet the different requirements of your material:

- Turn the variable speed adjustment dial clockwise to decrease the feed rate to accommodate harder material stock and prevent chipping.
- Turn the dial counterclockwise to increase the feed rate to accommodate rough stock or softer material.

Step 11: Feed the Workpiece Through the Planer

WARNING

Make sure the workpiece is free of nails, loose knots, and other defects that could cause personal injury or damage the knives.

Keep fingers and hands away from the cutting area. Keep hands away from the top surface of the board near the feed rollers.

Remove wood chips and shavings only with the power off. The main on/off power switch should be turned to the off position before any maintenance is performed on the machine.

Stand to the side of the workpiece when feeding it through the planer to avoid potential injury from kickback and loose chips.

If it is necessary to stop a workpiece before it is entirely fed through the machine, hit the emergency stop button. WAIT until the cutterhead has completely stopped. Reset the emergency stop button before lowering the table to remove material. Do not attempt to start the feed or the cutterhead until material has been removed from the planer. Attempted removal while cutterhead is turning may cause kickback.

Avoid Kickback

It is very important that each workpiece be carefully inspected for stock condition and grain orientation before running through the machine. "Pull-out" and the dangerous kicked back material can result when the workpiece has knots, holes, or foreign materials such as nails. Kickback can also occur when the material is fed against the grain on the cutterhead.

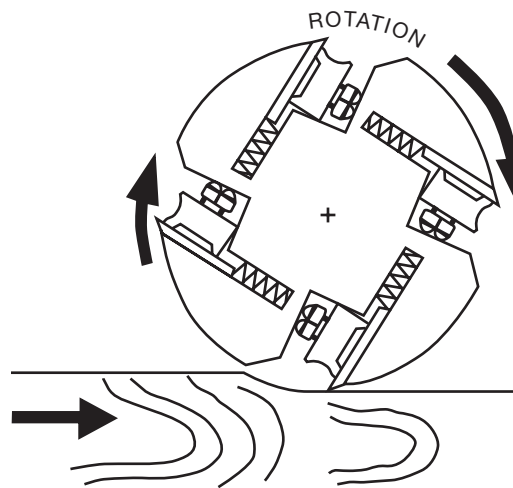

Always feed the workpiece against the cutter rotation.

The maximum depth of cut is 5/16" (8mm)*, so it may be necessary to pass the workpiece through several times to achieve the desired depth of cut.

Step 12: Normal Machine Stop

1. Press the red Infeed Off button.
1. Press the red Cutterhead Off button.
2. Turn the red Power knob to Off.
3. Make sure the work area is clean.

6.3 Tool Adjustments

 **WARNING**

Tools are extremely sharp. Be careful when working with tooling as serious injury may occur.

 **CAUTION**

Always disconnect the machine from its power source before making any adjustments.

To reduce kickback, use only tools that conform to EN 848-1:2005 and EN 848-2:2001, and that are marked MAN.

Refer to the tool manufacturer's recommendations for clamping and setting of tools.

To ensure safe and efficient cutting, the tooling should be suitable for the material being cut. The tools should be sharp and properly set.

Use extra precautions when handling tools and always use tool carriers.

*Maximum cutting depth is determined by wood characteristics.

7.0 Maintenance

⚠ WARNING

Before performing any type of maintenance or adjustments, make certain that the machine is disconnected from its power source and turned completely off.

⚠ WARNING

Never operate the machine until it has been properly lubricated and all necessary maintenance work has been completed.

NOTE: After changing a setting, making an adjustment, performing repair/maintenance work, or troubleshooting, please check that all applicable safety functions are working properly before performing another operation.

Clean all machinery parts and surrounding areas every day.

Keep a maintenance record and perform recommended maintenance checks.

7.1 Lubrication

Lubricate at the points listed below:

Index	Position	Interval	Type of Oil
A	Feed roller bushings	Oil daily	SAE-30
B	Table lift screws (4)	Weekly	Grease
C	Table slide ways (4)	Weekly	SAE-30

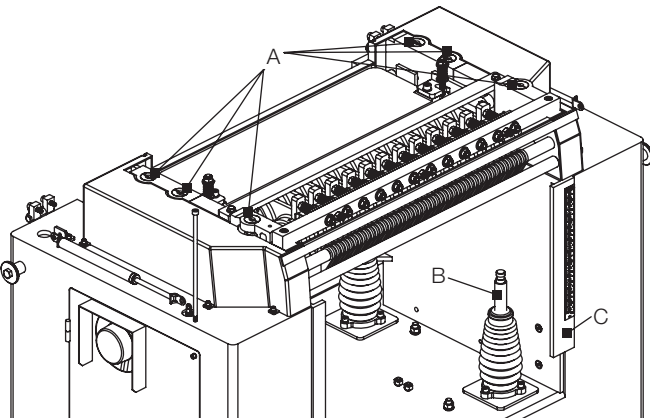

Do not get oil on the pulleys and belts. If they are dirty, use a paper towel or a soft rag to clean and dry them.

7.2 Inspection

Feature	Interval/Situation
Cutterhead	Daily
Belt	Every 1,000 hours of use or check belt whenever it becomes frayed
Emergency stop	Daily—by functional test
Safety guard/dust hood	Daily—by functional test
Roller tension	Daily
Electrical cabinet/system	Monthly—check wiring, loose terminals, insulation deterioration, voltage checks

7.3 Periodic Maintenance

It is important to periodically vacuum the inside of the machine, as wood shavings, dust, or other debris may accumulate. Take care to prevent dust from embedding on moving parts. Periodic machine cleaning increases the life of the machine and enhances its performance.

To replace ball bearings, please contact Stiles Parts Dept. at 1-800-727-8780.

8.0 Troubleshooting

Trouble	Possible Cause	Solution
Machine will not start.	<ol style="list-style-type: none"> 1. Fuse is blown or circuit breaker is tripped. 2. Electrical cable is damaged. 	<ol style="list-style-type: none"> 1. Replace fuse or reset circuit breaker. 2. Have cable replaced by authorized electrician.
Overload kicks out frequently.	<ol style="list-style-type: none"> 1. Feeding stock too quickly. 2. Cutterhead blades are dull or have debris build-up. 3. Removing too much stock. 	<ol style="list-style-type: none"> 1. Feed stock at a slower rate. 2. Clean, sharpen, or replace cutterhead knives. 3. Multiple passes.
Tool does not come up to speed.	<ol style="list-style-type: none"> 1. Low current / single phasing. 2. Motor is not wired for the correct voltage. 3. Poor v-belt tension. 	<ol style="list-style-type: none"> 1. Contact authorized electrician. 2. Refer to the motor nameplate for correct machine voltage. 3. Adjust v-belt tension.
Poor cut quality.	<ol style="list-style-type: none"> 1. Dull insert cutters. 2. Gum or pitch on cutter. 3. Gum or pitch on table causing erratic feed. 4. Feeding workpiece in wrong direction. 	<ol style="list-style-type: none"> 1. Replace inserts. 2. Remove inserts and clean. 3. Clean table. 4. Feed workpiece against cutter rotation.
Stock burns.	<ol style="list-style-type: none"> 1. Dull cutterhead inserts. 2. Cutting depth too deep. 3. Forcing workpiece. 	<ol style="list-style-type: none"> 1. Replace inserts. 2. Take shallow cuts on hardwoods; make a full depth cut with several passes. 3. Slow down feed speed.
Machine vibrates excessively.	<ol style="list-style-type: none"> 1. Damaged tooling. 2. Machine set on uneven floor. 3. Bad v-belts. 4. V-belt does not have proper tension. 5. Improper motor mounting. 	<ol style="list-style-type: none"> 1. Inspect cutterhead and replace inserts. 2. Reposition on flat, level surface. 3. Replace v-belts. 4. Adjust v-belt tension. 5. Check and adjust motor mounting.
Blowout	<ol style="list-style-type: none"> 1. Feed direction. 2. Tooling. 3. Tooling / cutterhead direction. 	<ol style="list-style-type: none"> 1. Make cross-grain cuts first and then finish with grain. Use scrap block to support at end of cut. 2. Inspect and replace inserts. 3. Check cutterhead rotation.
Snipe	<ol style="list-style-type: none"> 1. Chipbreakers set too high. 2. Outfeed rollers set too high. 3. Outfeed rollers set too low. 4. Stock not butted together. 5. Bed rollers set too high. 6. Grain running against knives. 	<ol style="list-style-type: none"> 1. Adjust chipbreakers and rollers. 2. Smaller materials may need to be butted together. 3. Adjust bed rollers. 4. Work in the direction of the grain whenever possible.
Tear out	<ol style="list-style-type: none"> 1. Feed is set too fast. 2. Moisture content is out of spec. 3. Cut is too deep. 4. Cutting angle is too large / worn inserts. 5. Grain running against insert knives. 	<ol style="list-style-type: none"> 1. Adjust feed speed. 2. Be sure stock has an acceptable moisture content. 3. Make shallow passes. 4. Replace inserts. 5. Work in the direction of the grain whenever possible.
Thickness of workpiece varies.	<ol style="list-style-type: none"> 1. Pressure springs on feed roller and hold down are too light. 2. Cutterhead or bed not aligned. 	<ol style="list-style-type: none"> 1. Adjust spring pressure. 2. Call Stiles Technical Support.
Chip marks on stock.	<ol style="list-style-type: none"> 1. Insufficient dust collection. 2. Feed is set too fast. 3. Inserts are dull. 	<ol style="list-style-type: none"> 1. Provide adequate dust collection. 2. Adjust feed speed. 3. Replace inserts.

Continued

Trouble	Possible Cause	Solution
Panels are tapered across width.	<ol style="list-style-type: none"> 1. Planer bed is out of parallel with cutterhead. 2. Knives not set evenly in cutterhead. 	<ol style="list-style-type: none"> 1. Call Stiles Technical Support. 2. Check cutterhead carbide inserts and reinstall if not set evenly.
Undesired glossy finish.	<ol style="list-style-type: none"> 1. Inserts are dull. 2. Feed is set too slow. 	<ol style="list-style-type: none"> 1. Replace inserts. 2. Adjust feed speed.

If you cannot resolve your issue, contact Stiles Technical Support at 616.698.6615.

8.1 Electrical Print

