

SLIDING TABLE SAW

SL 200

ORIGINAL OPERATING MANUAL



- Before you use the machine , please carefully read the manual and obey all related notes for safety and instructions.
- This manual is a part of the machine , so please make sure to include this manual when the machine is moved , transferred and sold.

PLEASE CAREFULLY READ THIS OPERATING MANUAL BEFORE USE

Thank you very much for your purchasing our SCORING TABLE SAW.

For personal safety and excellent performance of the machine, please first carefully read the Operating Manual and other attachments to be familiar with the machine's functions, safe instructions and notes.

- NOTES
1. The contents in this Operating Manual may be changed without pre-notice. Sorry.
 2. The contents in this Operating Manual have been carefully noted. In case there is a mistake that directly or indirectly results in damage, sorry our company will not be responsible for it.
 3. This Operating Manual is a part of the machine, so please make sure to include it when the machine is moved, transferred and sold.
-

SAFE INSTRUCTIONS

1. If you are not fully familiar with the machine's operation, you must be instructed by your supervisor or qualified person.
2. If the running direction of the saw is wrong, it will cause danger.
3. The anti-skid floor cushion is put at the operator's standing area and the machine's working area. There should be a proper working space around the machine.
4. When the saw doesn't completely stop, please don't use extra pressure to stop it.
5. Don't operate the machine until the saw guard is well installed.
6. Please wear the approved safety glasses to protect eyes.
7. Before you repair or maintain the machine or change saw, please first shut down the machine's power.
8. When you rip small work piece (<120mm), please use the push stick or wood block.
9. When the saw hasn't completely stopped, please don't adjust the saw guard.
10. When power is ON, don't clean saw and don't use hands to clean sawdust and use brush to clean chips.
11. Confirm if the machine is well installed with the earth wire.
12. When you finish the job or operator leave the working area, please make sure to turn the power to OFF.
13. While working, don't fail to pay full attention. Looking around, talking and clamoring are careless behaviors and will incur serious injury.
14. While operating the machine, please keep stable, balanced and coordinated gesture. Operator and others can't stand at the same line with the saw or the work piece.
15. While the machine is running, no matter if the guard is installed, don't go near the saw or attach yourself to the machine.
16. The weight of work piece can't exceed 70kgs.
17. Before you replace parts, maintain or repair the machine, please first shut down the machine's power.
18. Only tools made in conformity to EN 847-1 : 1997 shall be used on the machine.
19. It should have enough lights and lighting around the machine's place location.
20. Machine use for cutting for small amount or quantity and various working piece, it may cut the wood, aluminum, imitation marble...non metal material. Prohibit to cutting the steel metal stuffs.



EXPLANTION OF WARNING SIGN

To secure safety

Please make sure to carefully read the safe instructions to be familiar with the machine's functions, safe information and notes before you start, run & start the machine.

Please carefully read the trouble-shooting guide to be familiar with the machine's functions, safe information and notes before you repair or check the breakdown.

If you wrongly operate the machine, different degrees of personal injury or damage may happen. So, to avoid such wrong operation, we list the following 3 classes of warning signs:

WARNING SIGN	WARNING CLASS	WARNING CONTENTS
 DANGER	DANGER	If you wrongly operate it, assume the user to be dead or seriously injured with high danger.
 WARNING	WARNING	If you wrongly operate it, assume the user to be dead or seriously injured.
	NOTE	Remind the user to surely close power.

It's listed as “ **CAUTION** ”, but the related serious damages may happen as per different situations.

The definition of “ seriously injured ”, “ lightly injured “, “ property damaged “ shown in the above contents is as follows :

Seriously injured : Because of becoming blind, injury, electric shock, bone fracture, there is an after-effect that requires to stay hospital or go to hospital for treatment for a long time.

Lightly injured : Don't need to stay hospital or go to hospital for treatment for a long time.

Property damaged : Property and machine are directly or indirectly damaged.

CATALOG

SAFE INSTRUCTIONS	1
EXPLANATION OF WARNING SIGN	2
1. BRIEF INTRODUCTION TO MACHINE	
1-1 SPECIFICATION	1-1
1-2 MACHINE DIMENSION	1-1
1-3 FEATURES	1-2
1-4 INDICATION	1-3
1-5 RIVING KNIFE SPECIFICATION	1-4
1-6 PROTECT SWITCH ON THE END OF SLIDIN TABLE	1-5
2. SPARE PARTS ASSEMBLY UNIT	
2-1 TRANSPORT	2-1
2-2 SLIDING TABLE UNIT	2-3
2-3 CROSSCUT TABLE UNIT	2-5
2-4 CROSSCUT FENCE UNIT	2-6
2-5 RIP FENCE UNIT	2-7
2-6 EXTENSION TABLE	2-8
2-7 DUST GUARD UNIT	2-10
2-8 MITER FENCE UNIT	2-14
2-9 RIVING KNIFE UNIT	2-15
2-10 MAIN SAW UNIT	2-16
2-11 SCORING SAW UNIT	2-19
3. OPERATING UNIT	
3-1 POWER CONNECTION	3-1
3-2 OPERATION OF CONTROL PANEL	3-3
3-3 PRESENT SIZE CORRECTION	3-4
3-4 PARAMETER SETTING	3-5
4. CLEAN & MAINTAIN UNIT	
4-1 MAINTENANCE OF THE SLIDING TABLE	4-1
4-2 MAINTENANCE OF ANGLE SLIDE RAIL	4-1
4-3 SAFETY CHECK 【CE】	4-2
5. TROUBLE SHOOTING GUIDE	5-1
6. 3D SYSTEM DRAWING	
6-1 BODY UNIT	
MACHINE BODY	6-1
SUPPORTING ROCKER ARM	6-3
ROTARY BASE	6-4
6-2 SAW BLADE UNIT	
MAIN SAW	6-6
MAIN SAW ELEVATOR AND TILT	6-8
SCORING SAW	6-10
6-3 MOTOR UNIT	
MAIN SAW MOTOR	6-12
SCORING SAW MOTOR	6-14

6-4 TABLE UNIT	
MAIN TABLE	6-15
SLIDING TABLE	6-16
CROSSCUT TABLE	6-19
EXTENSION TABLE	6-20
6-5 FENCE UNIT	
RIP FENCE	6-21
RIP FENCE DIGITAL DISPLAY	6-23
CROSSCUT FENCE	6-25
CROSSCUT FENCE DIGITAL DISPLAY	6-27
MITER FENCE	6-30
6-6 SAFETY GUARD UNIT	
SIMPLE TYPE SAW GUARD	6-31
DUST-COLLECTING FASTENING RACK	6-32
SAFETY GUARD CONNECTING ARM	6-33
LUX SAW GUARD	6-34
6-7 OPTION ACCESSORIES UNIT	
RAPID CLAMP BASE	6-36
AUXILIARY CROSSCUT CARRIAGE	6-37
PNEUMATIC CLAMP	6-39
ON/OFF SWITCH ON THE END OF SLIDING TABLE	6-41

1. BRIEF INTRODUCTION TO MACHINE ▶▶▶

1-1 SPECIFICATION

Technical data , Standard and optional equipment

Unit : mm

ITEM	MODEL	SL200
Rectified cast iron fixed table dimension		570 × 1000
Sliding table dimension		380 × 2600
Main saw blade \varnothing 305 (12")		●
Main saw blade \varnothing 355 (14") / Max.		✓
Main saw bore		\varnothing 30 (\varnothing 25.4)
Max. cutting height with bade at 90°		105
Max. cutting height with bade at 45°		73
Main motor power 5hp (3.7kw)		●
Main motor power 7.5hp (5.5kw)		✓
Main blade speed		3000 / 4000 / 5000 RPM
Scoring swa blade \varnothing 120		●
Scoring swa blade bore		\varnothing 22
Scoring motor power 1hp (0.75kw)		●
Scoring blade speed 8000 rpm		●
Cutting width 1000mm		●
Cutting width 1300mm		✓
Cutting width 1500mm		✓
Cutting width adjustment		Manual
Saw table extension 370 mm		●
Saw table extension 720 mm (CE)		✓
Blade titing adjustment		Manual (0°~ 45°)
Main saw height adjustment		Manual
Scoring saw height adjustment		Manual
Scoring saw +/- direction adjustment		Manual
Blade titing angle show		Simple / Digital display
Main blade speed show		LED exhibit
Overhead saw guard		Simple / Luxurious
Crosscut fence digital display		✓
Rip fence digital display		✓
Rapid clamp		✓
Tool frame		✓
Noise level		78dB
Dust colection system		Main channel 4" , Simple guard 60 , Luxurious 3"

● = Standard ✓ = Additional extras

1-2 MACHINE DIMENSION

Space requirements

	SL200
A	3200
B	850 mm (1200 mm for CE)
C	1500
D	1725
E	1820
F	max.3230
G	3525
H	3470

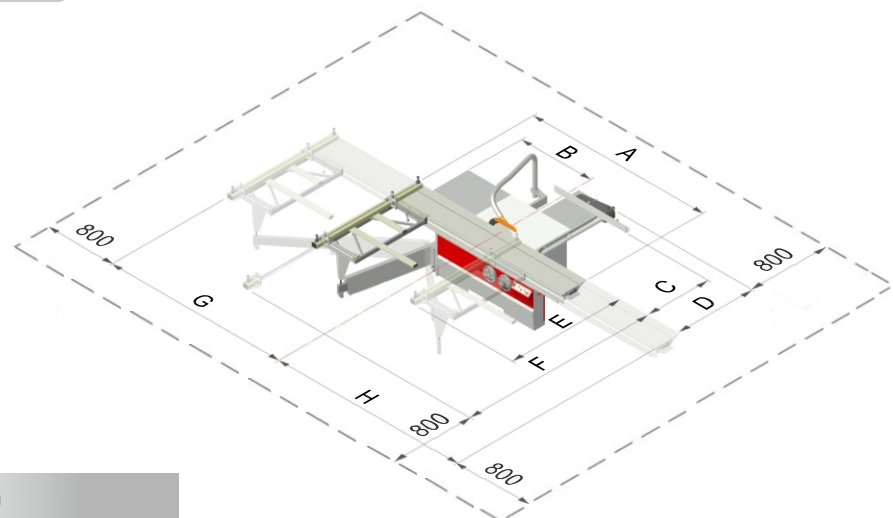

⚠ WARNING

A free space of minimum 800 mm around the external dimensions of the machine should be provided in order to prevent crushing and bumping danger.

Cutting depths

Saw blade diameter	255(10")	305(12")	355(14")
Cutting depths at 90°	0~55 mm (0~2.16 in)	0~80 mm (0~3.15 in)	0~105 mm (0~4.13 in)
Cutting depths at 45°	0~38 mm (0~1.5 in)	0~56 mm (0~2.2 in)	0~73 mm (0~2.87 in)

Cutting depths

Sliding table cutting lengths	With or without scoring saw blade
1900 mm (74.8 in)	1800 mm (70.87 in)
2600 mm (102.36 in)	2500 mm (98.53 in)
3200 mm (126 in)	3100 mm (122.05 in)

Machine weight

Mode	P-32		
Cutting width	1000 mm	1300 mm	1500 mm
Main crate N / W	760 / 810	770 / 820	780 / 830
Sliding table length	1900 mm	2600 mm	3200 mm
	103 / 153	157 / 217	187 / 247

1-3 FEATURES



- A : Dust guard**----- Not only reduce dust produced by chips while cutting, but also warning the operator where the saw-blade position.
- B : Main table**----- Main working table.
- C : Rip fence**----- Reference positioning while ripping.
- D : Sliding table**----- Table for main feeding while cutting.
- E : Controlling panel**----- Control the machine' s running, indication, stop etc.
- F : Main saw tilting adjusting hand wheel** ----- Hand wheel for adjusting main saw tilting 0~45°.
- G : Main saw lifting adjusting hand wheel** ----- Hand wheel for adjusting main saw up/down.
- H : Cross cut table**----- Used to put the workpiece while cross cutting.
- I : Cross cut fence**----- To position the size of the movable positioning board.
- J : Movable positioning stops**----- To position while cross cutting.

1-4 INDICATION

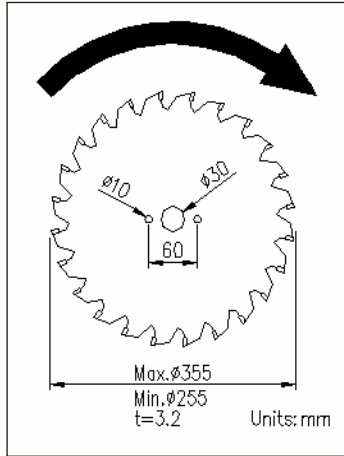

Fig.1

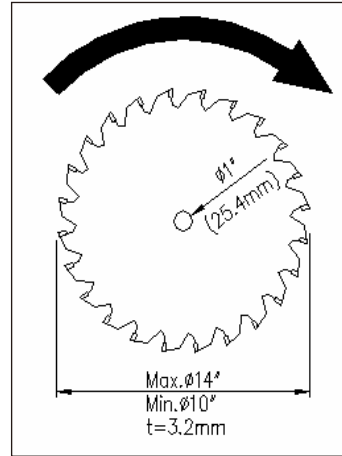

Fig.2

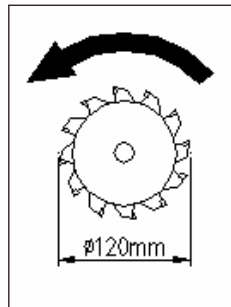

Fig.3

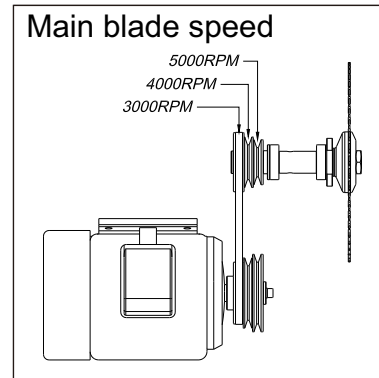

Fig.4

Note

Fig.1 : the main saw's size and running direction.

Fig.2 : the main saw's size and running direction.

1-5 RIVING KNIFE SPECIFICATION

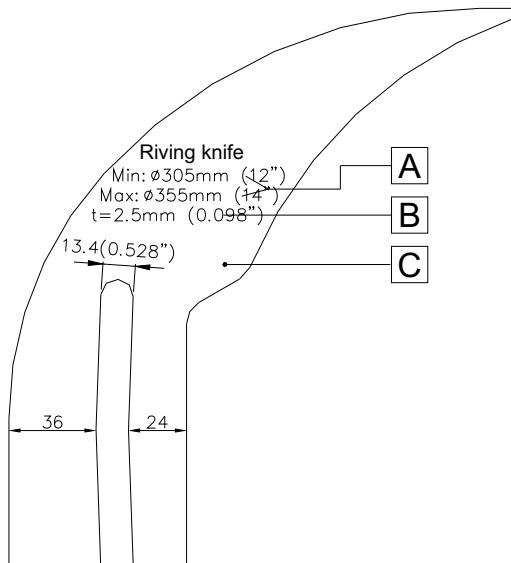

- A : Available Main Saw diameter range.
- B : Riving knife depth.
- C : Luxurious riving knife.

WARNING

Prior to setting the riving knife, check whether it matches the saw blade diameter and body thickness.
Always switch off the main switch prior to setting the riving knife preventing cause danger.

The machine is delivered as standard with the following riving knives.

305~355 / 2.5 specification : Saw blade diameter 305~355mm.

Saw blade basic body thickness up to maximum : 2.5mm.

Diameter range and thickness are both engraved at the bottom end of the riving knife.

The thickness of the riving knife was selected so that they match the commercially available saw blade thickness in the respective diameter

A: Should you accidentally press the ON button when changing saw blade, this protect switch is able to keeps the saw blade standstill so that the operator won't get hurt.

B: Fig. 1 is the default installation



Default Installation

Fig. 1

C: How to adjust this protect switch

- (a) Make the limit switch touches on the fix bracket touches the touch block
- (b) Please refer to Fig. 2

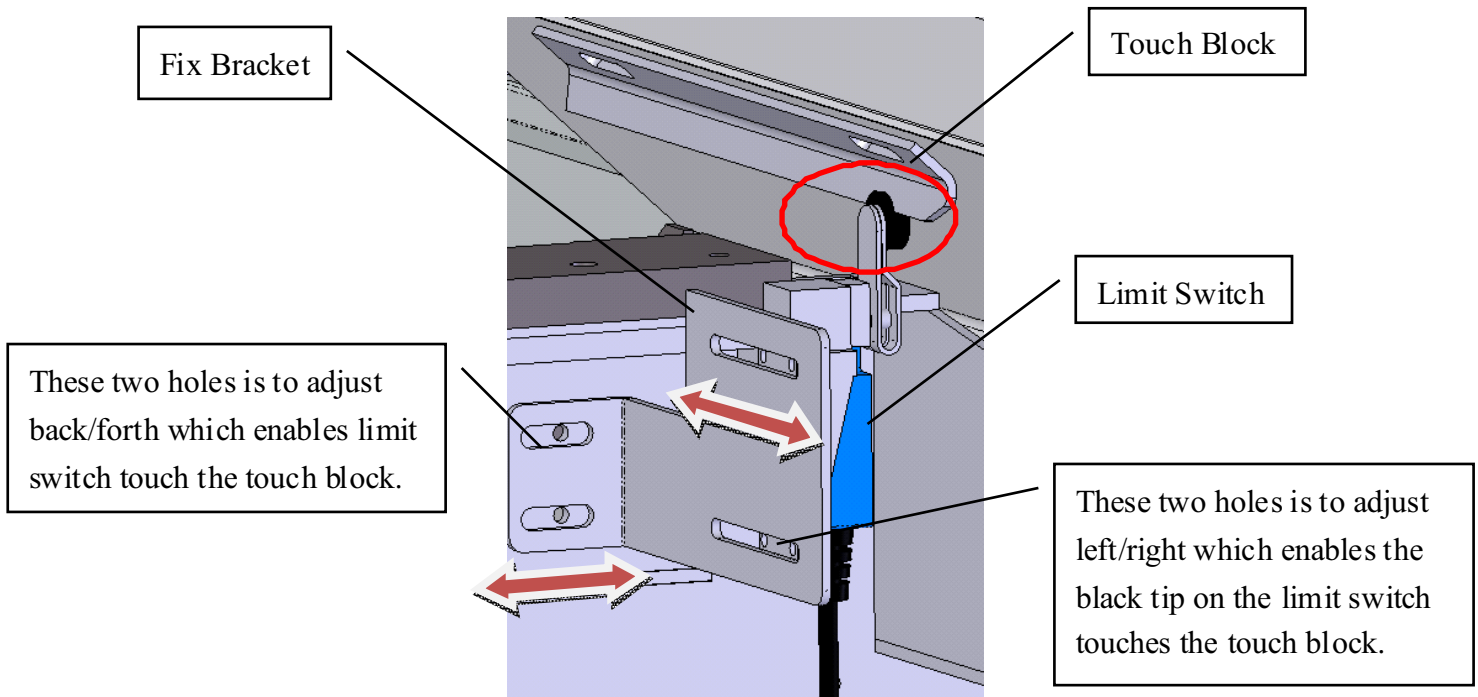

Fig. 2

2. SPARE PARTS ASSEMBLY UNIT ▶▶▶

2-1 TRANSPORT

TRANSPORT WOODEN CRATE

⚠ WARNING

To transport the machine, please request the person who has licenses of gantry, crane, lift truck, etc, to operate. The weight of machine is listed in the chapter 2-1 and 2-2. After confirming, please proceed as per the weight. To suspend and move the machine, please follow Notes of Chapter 2-1 and 2-2 to operate. During transport, if the machine collapses or drops, it will cause an accident. While transporting or assembling, please don't damage the wiring. After assembly is completed, please execute protective measures to avoid the workers, other persons or lift truck damaging the wiring.

The machine's gross weight is about :

Body box(Cutting width 1m) : 810kgs

Body box(Cutting width 1.3m) : 820kgs

Body box(Cutting width 1.5m) : 830kgs

Please refer to Chapter 1-2 for detailed data.

1. USE CRANE TO MOVE WOODEN CRATE

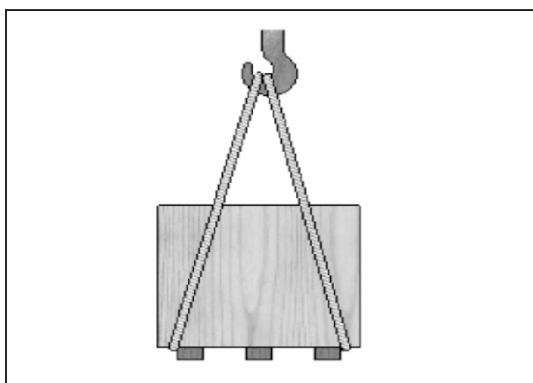

⚠ WARNING

The crane's rope must be able to bear the machine's gross weight to prevent its breaking from happening danger.

2. USE LIFT TRUCK TO MOVE WOODEN CRATE

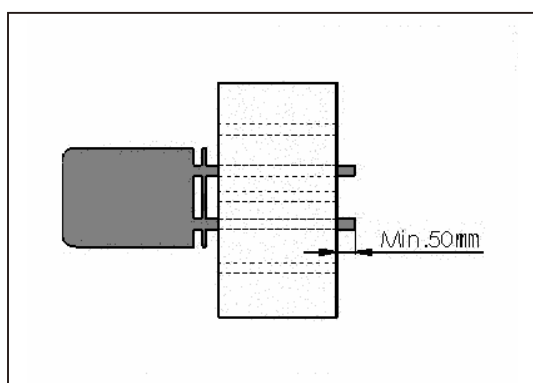

⚠ WARNING

Please put the wooden crate in the middle of the forks and keep over 50mm distance between the front of the forks and the wooden crate to avoid the case collapsing and secure safe transport.

TRANSPORT MACHINE

The machine's net weight is about :

Body (Cutting width 1m) : 760kgs

Body (Cutting width 1.3m) : 770kgs

Body (Cutting width 1.5m) : 780kgs

Please refer to Chapter 1-2 for detailed data.

1. USE LIFT TRUCK TO TRANSPORT MACHINE



WARNING

- The lift truck must be able to bear to least 5tons.
- Make sure the machine is balanced. While transporting, please don't vibrate it and keep at least 2m safe distance away from the transport area.
- The machine is equipped with the slots as shown in left Fig. that are specially designed for transport of

2. USE GANTRY OR CRANE TO MOVE MACHINE AWAY PALLET



Fig.1

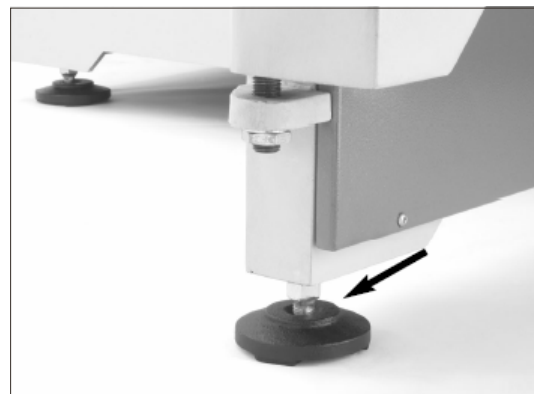

Fig.2

WARNING

- Before the machine is put on the floor, please first install level adjusting bases (as shown in Fig. 2 arrow marked) and adjust the level of the machine's working table to secure the sliding table's smooth movement and the machine's balanced running.
- Fig. 2 as marked is the machine after adjustment should be fixed to the floor.

2-2 SLIDING TABLE UNIT

ASSEMBLE



★Prior to setting sliding table , release the trimming planks (Fig.2-2-1). Ensure the trimming planks releasing before 1st working operation or the machine damaged.

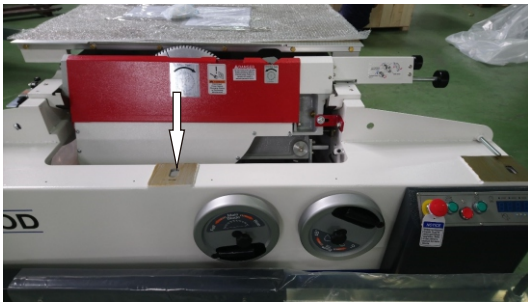

Clean the contact surface of the machine and the sliding table (Total 3 contact surfaces).

Put the sliding table on the contact surface and tightly against the adjusting screw.
Note : Ask persons to move the sliding table onto the machine to prevent hitting from influencing level during transportation. As per different size, the required manpower is 4-6 persons.

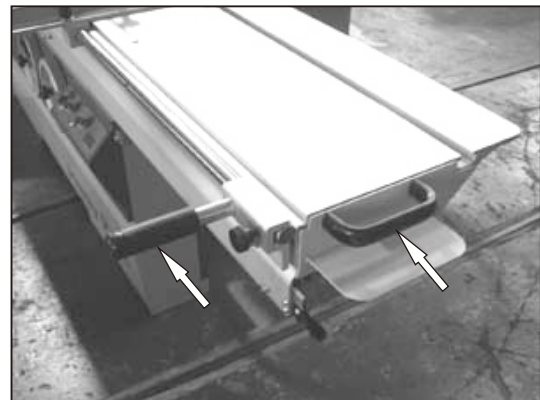
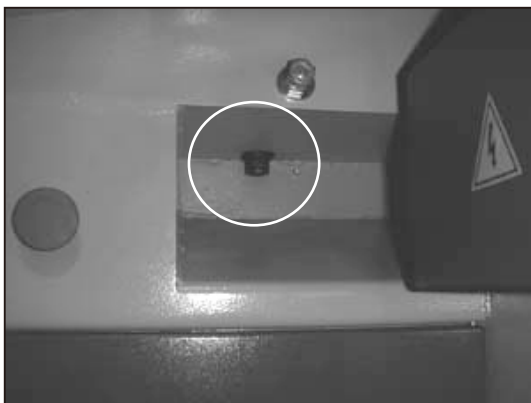

Tighten the fixing screw of the machine and the sliding table.

Put the handle and the sliding table handle onto the sliding table.
Note : After assembly of the sliding table is completed, the parallelism of the sliding table and the saw blade must be first adjusted.

ADJUST



Loosen 3 fixing screws.



Adjust the adjusting screws at two sides of the machine to make the sliding table parallel to the saw blade and keep the gap as shown in the left drawing with the working table. After assembling, tighten the fixing screws.

Note : The sliding table must 0.3mm higher than the working table (The height has been set before delivery, so don't freely adjust the height of the sliding table or the working table).

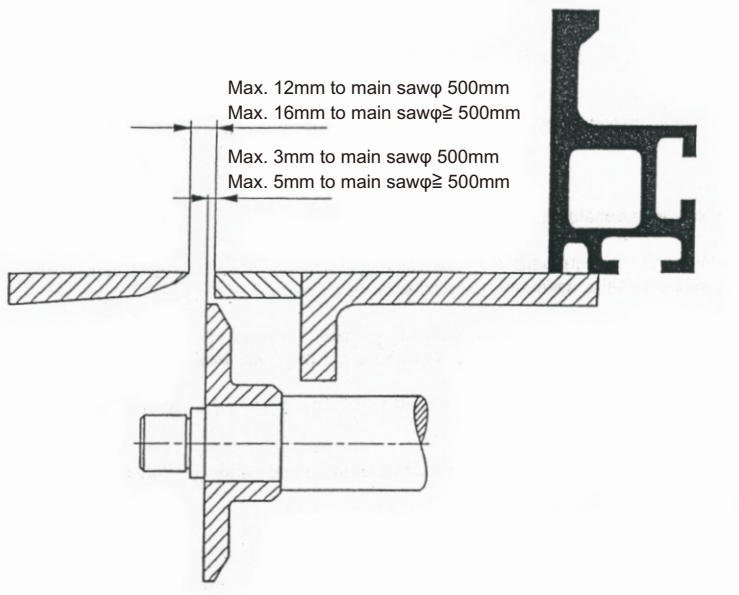
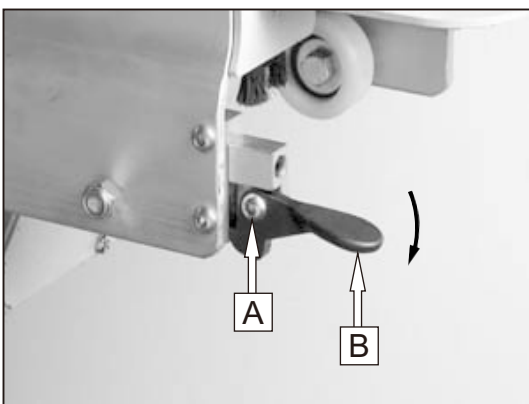

Fig. 1

How to Use the Sliding Table Lock



- Due to limitation of packing, Part A & B in the left drawing are put in the tool box before delivery.
- After the sliding table is installed at the back of the machine, please first install Part A & B at the position of the end of the sliding table in the left drawing.
- The safety lock can fasten the sliding table in the middle and the end.

Note : Before the sliding table is moved, make sure the safety lock is unlocked. Part Bin the left drawing is

2-3 CROSSCUT TABLE UNIT

ASSEMBLE



Put one end of the crosscut table into the projected round rod of the expansion pipe (apply the lubricating oil to the balls to prevent friction from



Put the other end on the round rod of the sliding table and put the locking bar under the round rod of the sliding table.

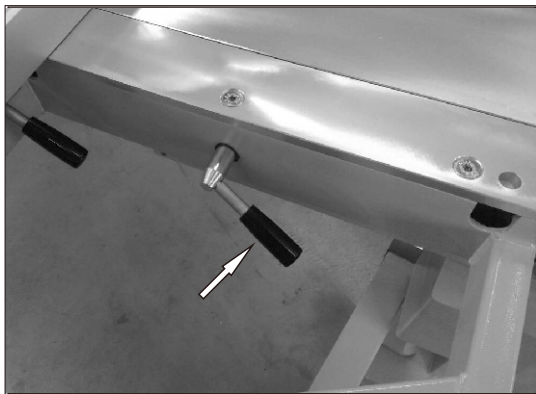

Tighten the handle to fasten the crosscut table.

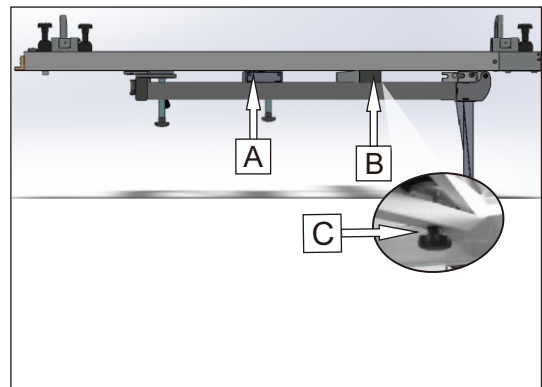

Put two C-shaped aluminum pipes into the crosscut table.

A aluminum pipe is the fixing aluminum pipe .
B aluminum pipe is the moving aluminum pipe (Use hand to tighten for fixing. Loosen **C** to make **B** aluminum pipe be movable).

ADJUST

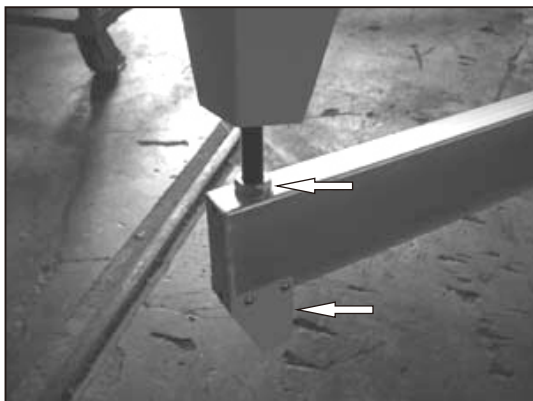

If the crosscut table isn't parallel to the working table, adjust the nut of the crosscut table and the expansion pipe and also adjust the nut in the cover plate. (See the left drawing.)

2-4 CUOSSCUT FENCE UNIT

ASSEMBLE

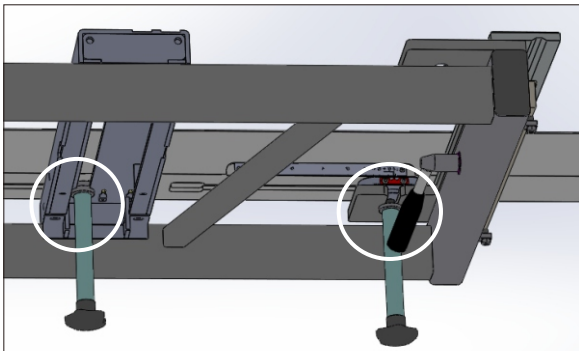

Put the crosscut fence into the positioning point of the crosscut table.

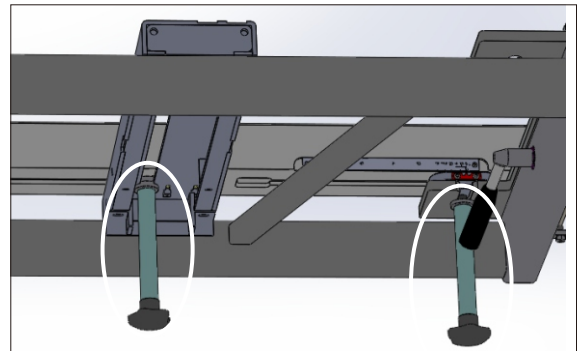

Press down the handle to fix the crosscut fence.

Note : If the crosscut fence is moved, please first adjust the perpendicularity of fence and saw blade before use.

ADJUST

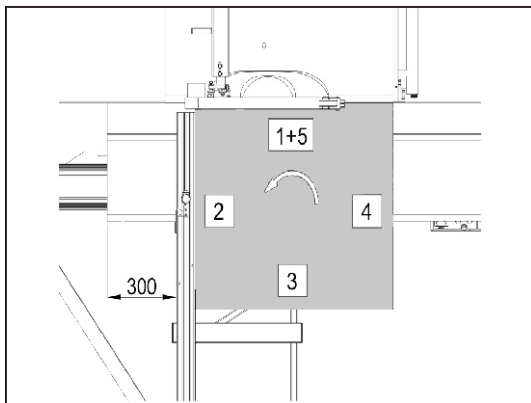

Fig.1

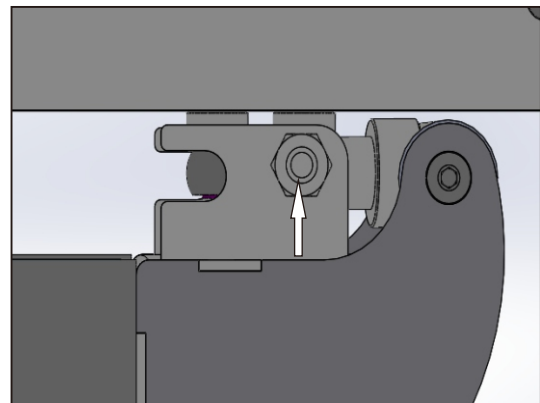

Fig.2

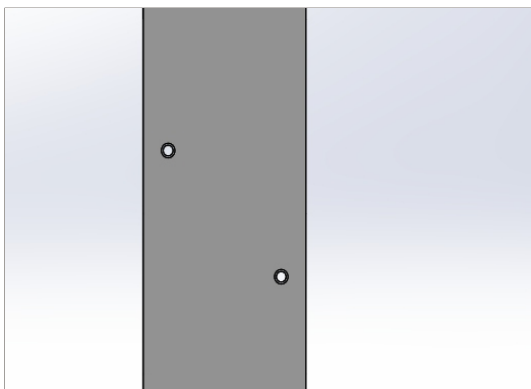

Fig.3

Adjusting Way :

- 1 . Please keep 300mm distance between the fence and the sliding table. While cutting, please use saw in dia. 350mm/3.2t/100T, at 5000 r.p.m speed and wood board in 1000x1000x19 or (6/8") for trial cut.
2. Sequentially cutting NO.1~5 as Fig.1.
3. Measure the diagonal's error of the wood board to proceed adjustment parts, lock the nut Fig.2 after adjustment.
4. The two knobs in the Fig.3 is to fasten the scale on the crosscut fence.

2-5 RIP FENCE UNIT

ASSEMBLE

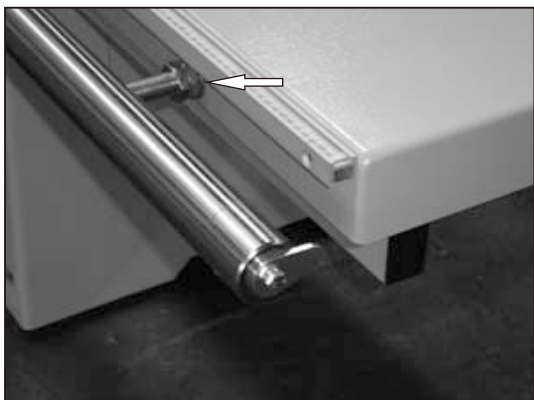

Lock the screw on the round rod into the right side of the working table, put into the rip fence base, adjust three nuts on the round rod to make rip fence parallel to the saw blade.

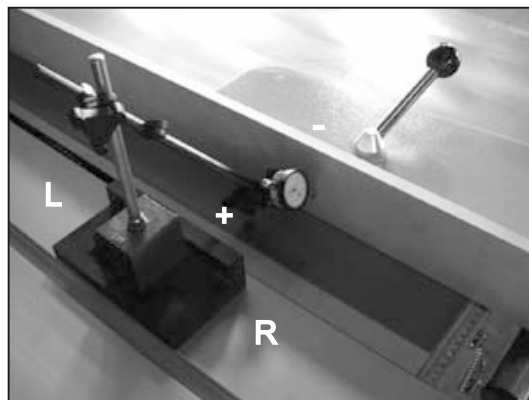

Use the gage to measure the parallelism of the rip fence and the main saw blade.
Measuring way : The rip fence is fixed and the sliding table is pushed to the left.
Measured tolerance is 0~0.1mm from the left to the right as the direction shown in the above drawing. (parallelism of the sliding table and the main saw blade must be first adjusted within tolerance.)



Adjust the eccentric wheel of the front end of the fence base to make the fence base parallel to the working table.



Adjust two eccentric wheels at the side of the fence base to make the aluminum fence parallel to the working table.



- Tighten the rip scale, adjust the limit screw on the stop block. The safe gap between the fence and the saw blade is suggested at 0.5mm.
- The screw at the left side of above drawing is the limit for cutting 90 degree.
- The screw at the right side of above drawing is the limit for cutting angle.

ADJUST

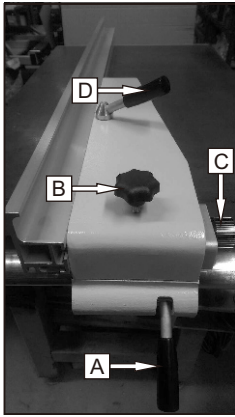

After the rip fence is moved, if the moving size and the target size have slight difference, the following is the operating way of the micro-knob :

1. Pull the handle (Part A) upwards, move the rip fence to near the target size.
2. Loosen the knob (Part B).
3. Turn the micro-knob (Part C) to the target size. To fasten rip fence, do above steps in reverse order. Clockwise turn micro-knob : - direction movement Anti-clockwise turn micro-knob : + direction movement. To change the aluminum fence, loosen the handle (Part D).

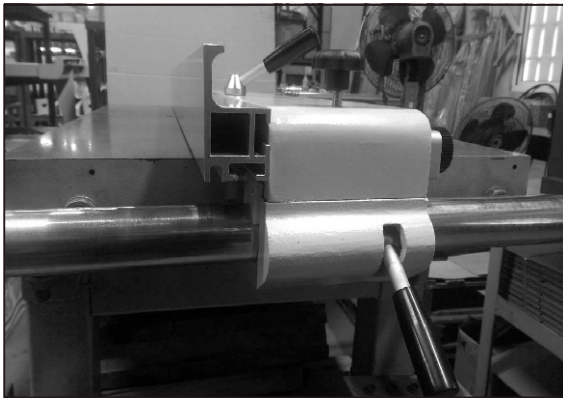

Above drawing is the position of aluminum fence at 90 degree cutting.

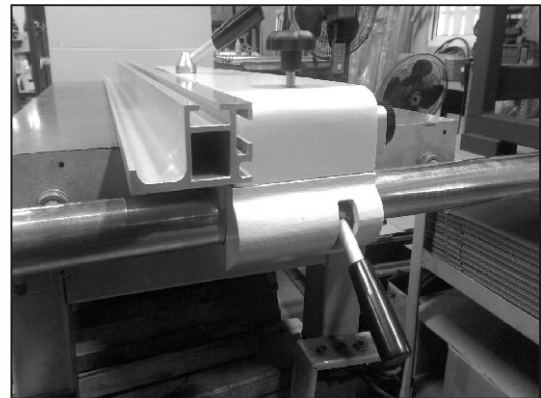

Above drawing is the position of aluminum fence at cutting angle.

2-6 EXTENSION TABLE

ASSEMBLE MAIN TABLE EXTENSION

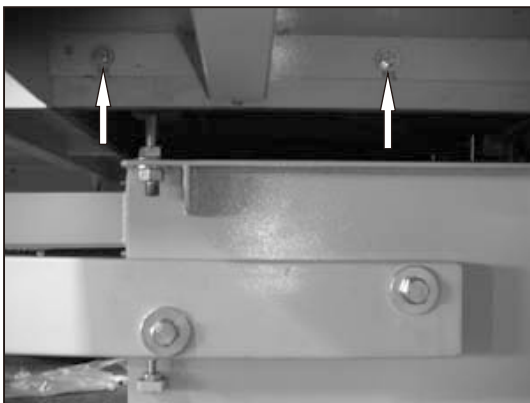

Loosen about 3~5mm of 3 metal sheet fixing screws at the left side of the machine, put extension metal sheet on the fixing screws and slightly tighten the screws.

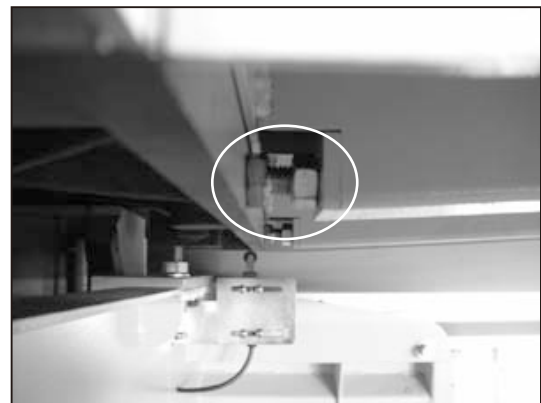

Adjust 2 adjusting bolts of the extension metal sheet to make the metal sheet and the main working table become a plane.

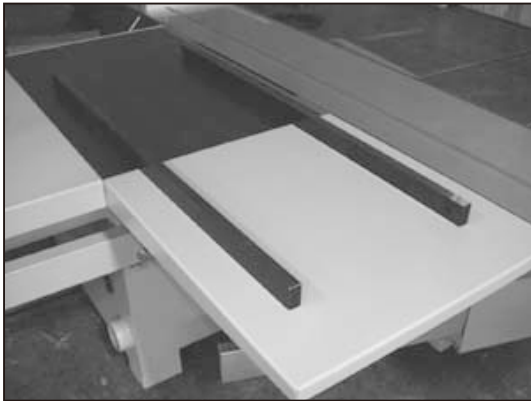

Measure if the main table extension and the main table become a plane.

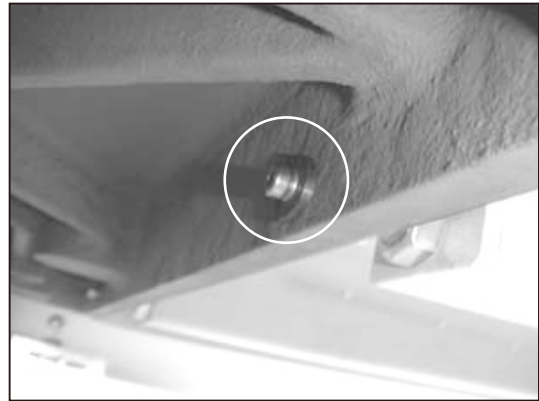

Adjust and fasten 2 adjusting bolts and 3 metal sheet fixing screws.

ASSEMBLE WIDTH EXTENSION TABLE



Lock the support into the back of the machine.

Note : The opening of the support must be outwards as shown in above drawing.



Loosen 3~5mm of 4 metal sheet fixing screws at the left side of the machine, put width extension table on the fixing screws, slightly tighten the screws.



Put the adjusting bolt on the metal sheet onto the support and adjust the nut to make width extension table and main table become a plane.



Measure if the width extension table and the main table become a plane.

2-7 DUST GUARD UNIT

SIMPLE TYPE SAW GUARD



Install the dust collection fixing rack and the dust collection pipe onto the left side of the machine as shown in above drawing.



Install the dust collecting hood on the ribbing knife, connect dust collection hose, use clamp to fix the hose as shown in above drawing.

Diameter of dust collection hose is ϕ 60mm.



Put the dust collection hose into the dust collection hole under the fixing rack.

Diameter of the fixing rack's hose is ϕ 60mm.



Put the dust collection hose into the dust collection hole .

Diameter of hose is 4".

WARNING

Before the machine is used to cut workpiece, Please make sure the dust collector work normally.

Note1 : The required air speed at the end of flexible tube is 30~34m/sec. The required air volume of the machine is 1220~1390 m³/hr. (43,000~49,000 cuft/hr)

Note2 :Antistatic and electrically conductive hoses only.

LUX SAW GUARD

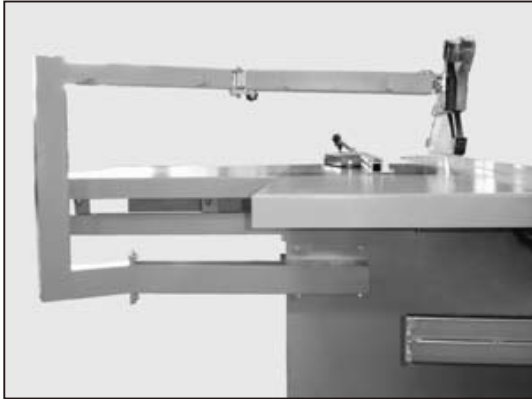

Install the dust collection fixing rack onto the left side of the machine as shown in above drawing.

WARNING

Before you install the safety guard, please lower the saw under the table.

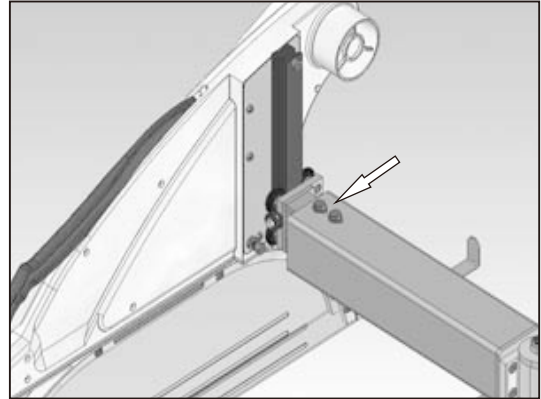

Adjust the guard parallel with the saw and tighten the screw as shown in above drawing.

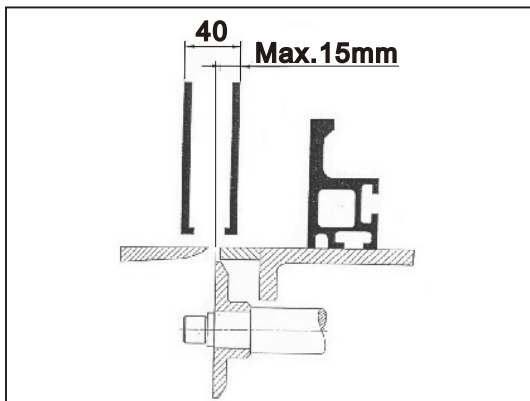

Please keep safe distance between the safety guard and the saw as shown in above drawing.

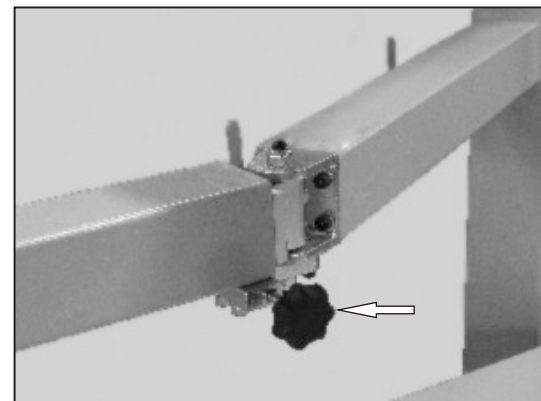

Tighten the knob to fix the guard. Loosen the knob, the guard can be moved as shown in above drawing.

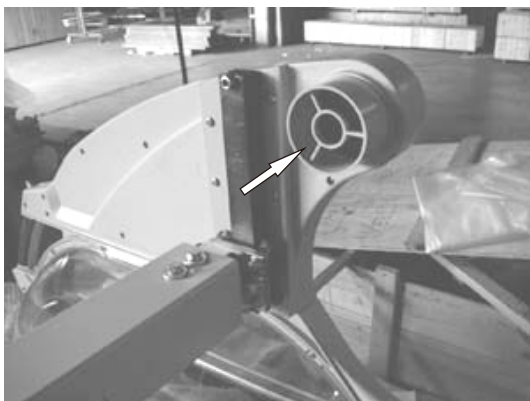

Put the dust collection hose into the dust collection hole at the back of the guard.
Diameter of hose at the back of machine is 3".



Put the dust collection hose into the dust collection hole .
Diameter of hose is 4".

⚠ WARNING

Before the machine is used to cut workpiece, Please make sure the dust collector work normally.

Note1 : The required air speed at the end of flexible tube is 30~34m/sec. The required air volume of the machine is 1220~1390 m³/hr. (43,000~49,000 cuft/hr)

Note2 : Antistatic and electrically conductive hoses only.

PUSHING STICK INSTALLING

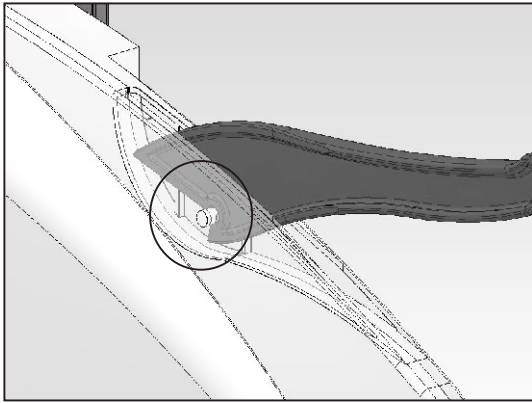

Install the pushing stick on the holder by degree 45.

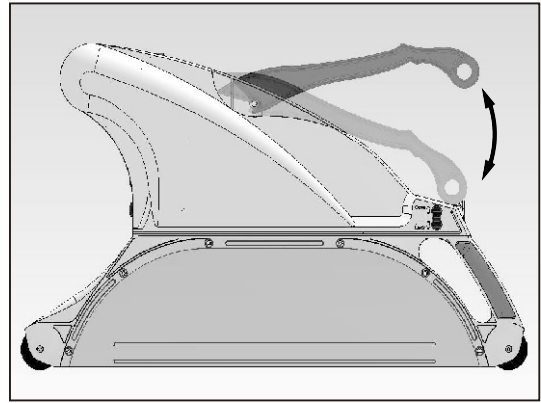

Lightly put down the pushing stick, then the pushing stick can be fixed.

ADJUST SAFETY GUARD

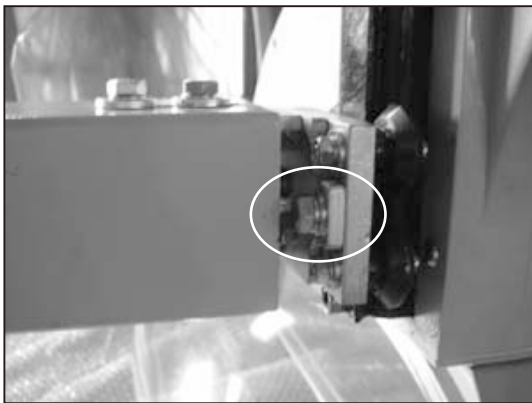

- Use hand to slightly move the saw guard up or down.
- The screw shown in left drawing is to adjust the tightness/looseness of up / down movement of the saw guard.
- The safety guard can be moved up to any place but must be firmly tightened at that place to avoid it moving down. After it's used for a long time, the part will be worn. So, please adjust its tightness again.

CHANGE SAFETY GUARD

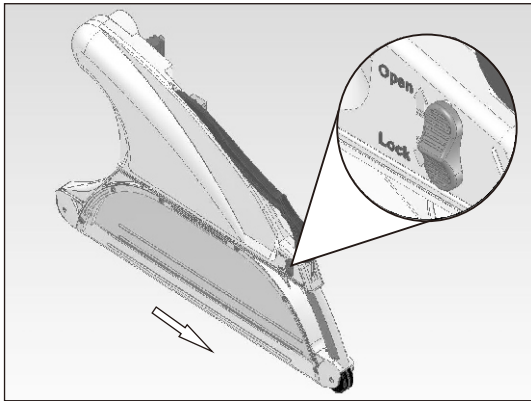

Push up the lock button on the saw guard loosen the saw blade shield to outward can be replacement.

WARNING

- In order to prevent the saw blade touch the saw shield during the replacement, kindly downward the saw blade to the bottom and move the saw guard unit to the upward.

- While cutting workpiece :

- At 90° cutting, 90° special safety guard must be used as Fig. 1.

- At angular cutting, special angular safety guard must be used as Fig. 2.

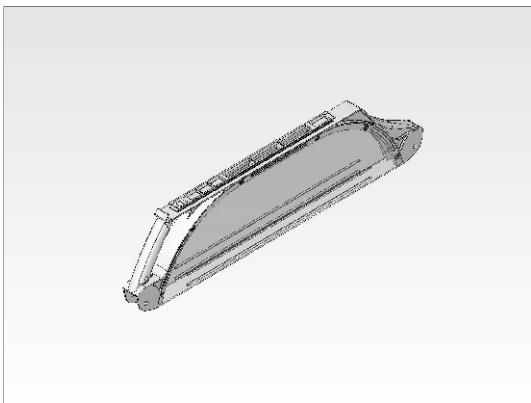

Fig.1

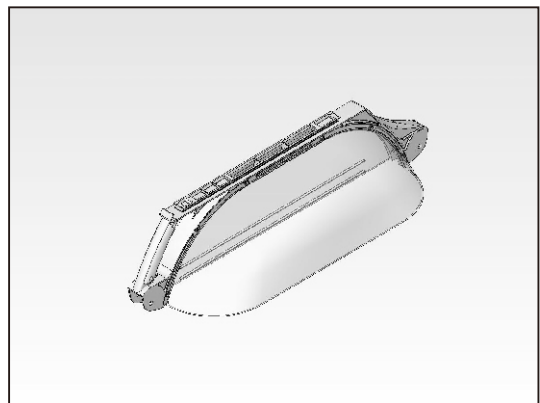
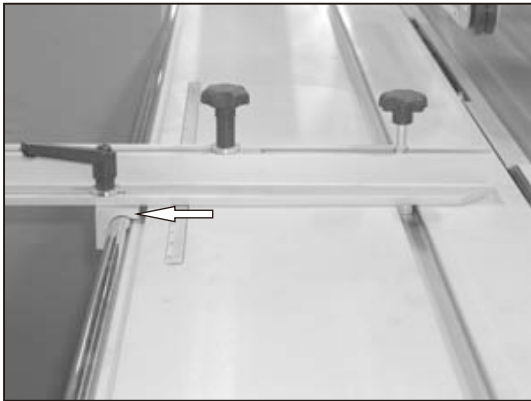

Fig.2

2-8 MITER FENCE UNIT

ASSEMBLE



Put the slide block on the bevel cutting fence into the round rod of the sliding table.

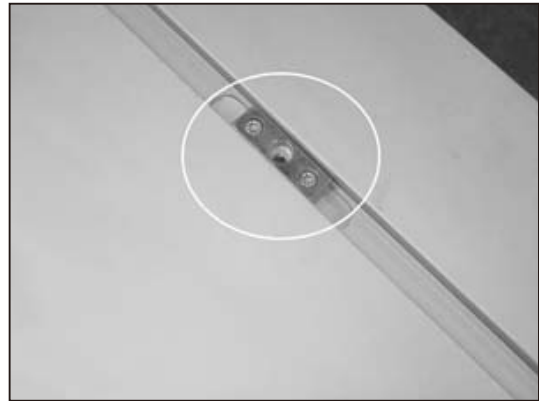

Lock the fixing block on the sliding table.

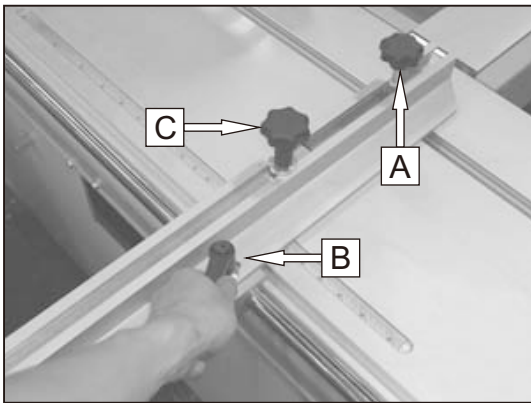

- Tighten knob A to fasten the center point of bevel cutting fence.
- Tighten handle B to fasten the bevel cutting fence. Loosen it to make the bevel cutting fence become an arc movement.
- Loosen knob C and push outwards to extend the bevel

2-9 RIVING KNIFE UNIT

ADJUST

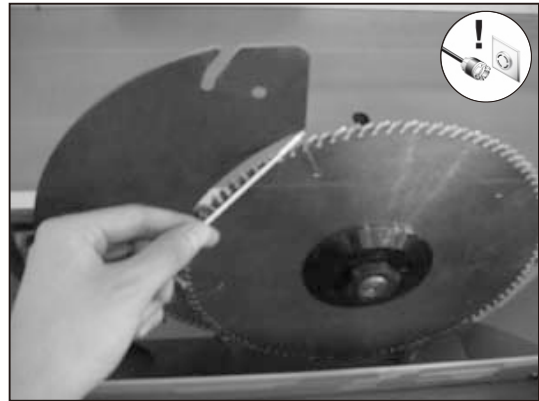
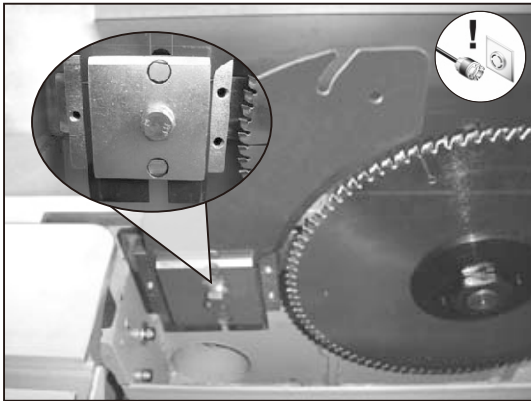

- Loosen the fixing screw on the riving knife base.
- Adjust the 3 adjusting screws at the two sides of the fixing screws as the projected place shown in the above drawing.

Note : Before adjusting the riving knife, please first open the saw blade guard. Please refer to 2-10 for detailed operation.

Measure the relative size of the riving knife and saw blade.

! WARNING

After adjustment of the riving knife is completed, please make sure to tighten the fixing screw on the riving knife base.

RELATIVE SIZE OF THE RIVING KNIFE AND MAIN SAW BLADE

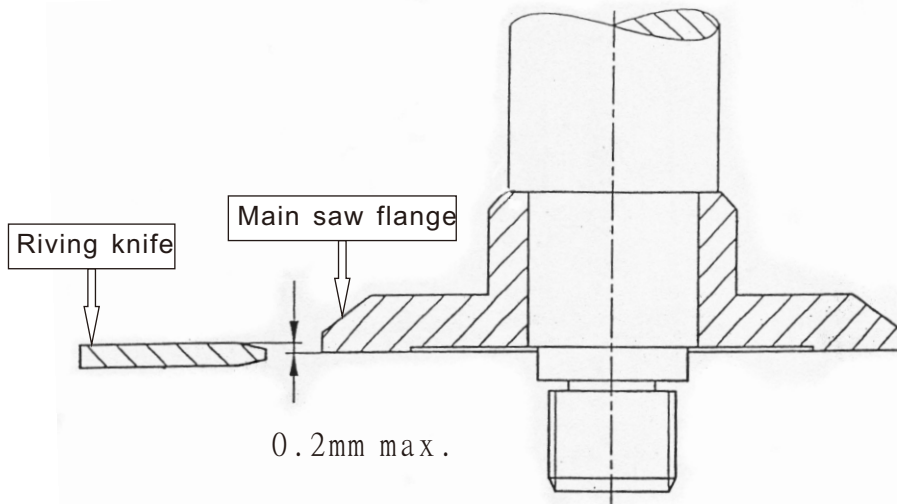
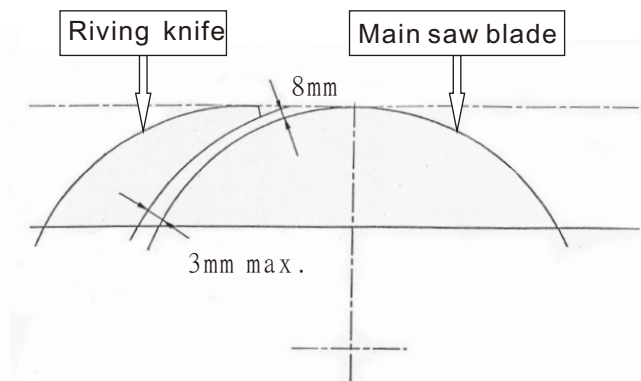
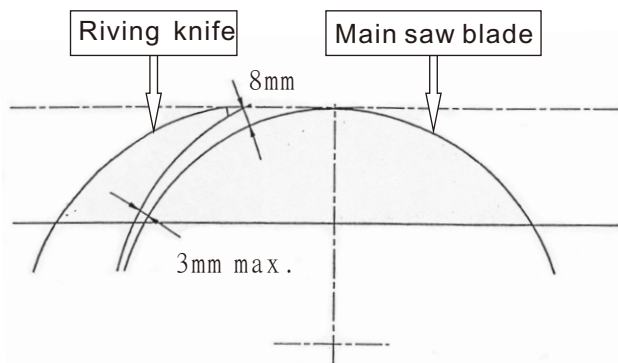

2-10 MAIN SAW UNIT

CHANGE MAIN SAW BLADE

⚠ DANGER

- Before changing saw blade, please confirm if power is closed.
- At changing saw blade, please put on the protective film to avoid any damage during changing.

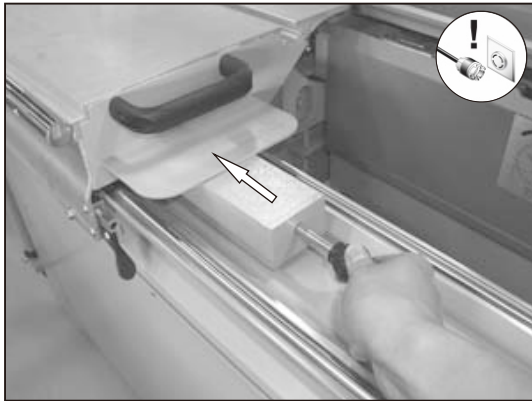

Push the sliding table towards the bottom. When the pusher rod is seen, push the ball on the pusher rod inwards to push the sliding table to the bottom.

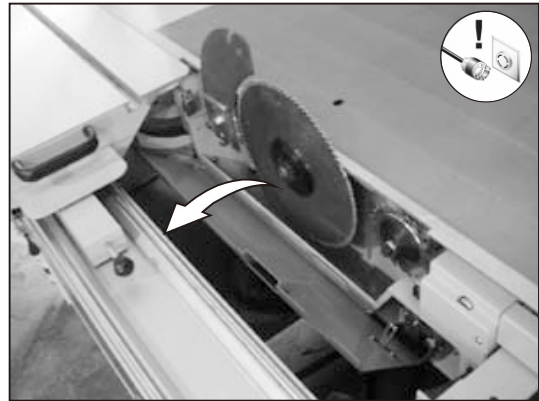

Open the saw blade guard.



Raise the main saw blade to the highest position. Turn the saw blade until the fixing pin is inserted into the spindle fixing hole.

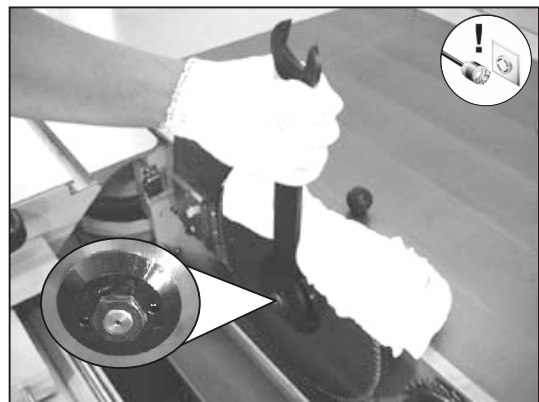

Use wrench to clockwise loosen the nut, clean the flange and new saw blade and then install them back to the spindle.

⚠ DANGER

The flange fixing nut of main saw blade must be tightened by torque 300kg/cm.

CHANGE SPINDLE'S ROTATING SPEED

⚠ DANGER

Change spindle's rotating speed, please confirm if power is closed.



Turn the saw blade's lifting hand wheel to lower main saw blade to the bottom.

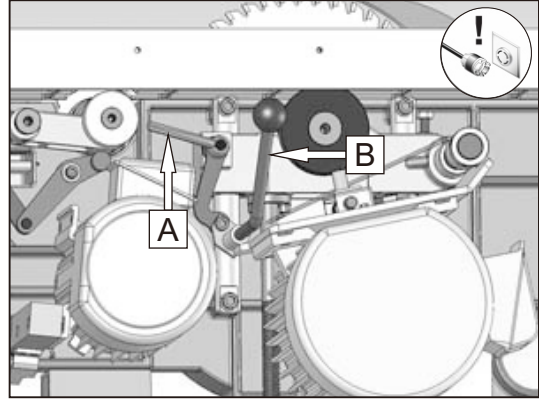

Open the service door at the back of the machine, loosen the adjust handle (Part A), press down the handle (Part B) to raise the motor.

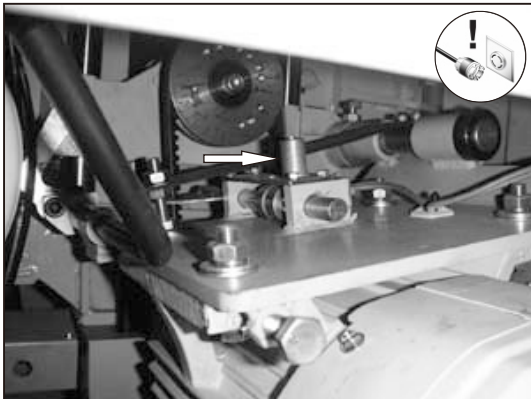

Pull the rotating speed knob upwards as shown in above drawing. Change the rotating speed knob and belt as per the motor's rotating speed list. After that, push the handle upwards to make belt produce tension. Tighten adjust handle. The change of rotating speed is completed.

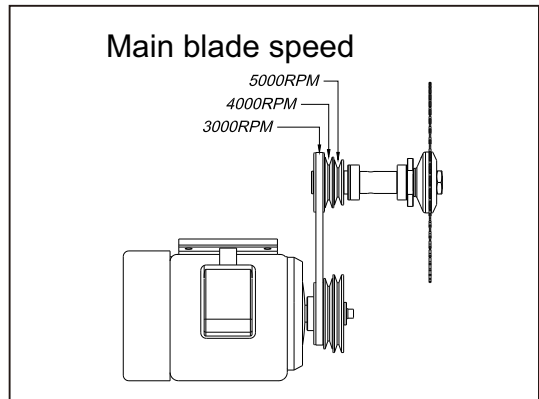

Above drawing is motor's rotating speed list. Speed in order of main blade to motor is 5000rpm、4000rpm、3000rpm.

ADJUSTMENT FOR MAIN SAW HEIGHT AND TILTING.

Hand wheel operation

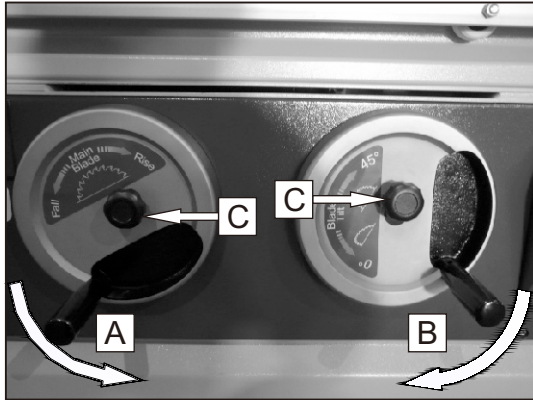

A. Hand wheel for main saw blade height adjustment. (As displaying in the diagram, the arrow direction is downward, on the contrary, upward.)

B. Hand wheel for main saw blade tilting adjustment. (As displaying in the diagram, the arrow direction is tilting angle increasing, on the contrary, tilting angle decreasing.)

C. After adjusting the hand wheel, please lock up the knob as the C part in the diagram for fixing the hand wheel.

Digital display

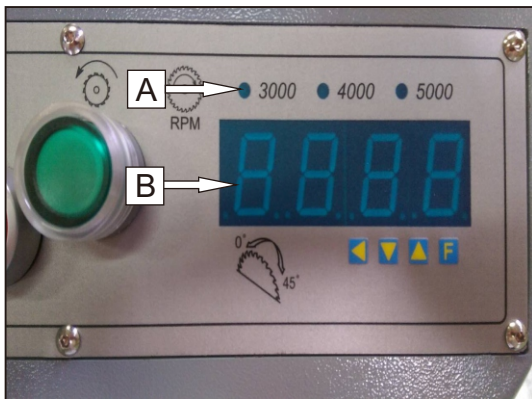

A : Speed display for main shaft.

B : Tilting angle display for main saw blade.

2-11 SCORING SAW UNIT

OPERATE

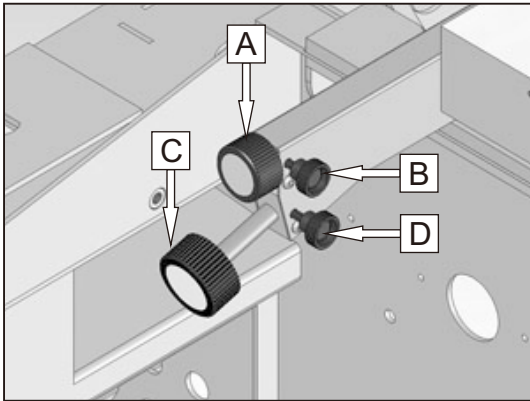

A : Forward/backward adjusting knob.

B : Forward/backward fixing knob.

C : Lifting displacement knob.

D : Lifting fixing knob.

CHANGE

⚠ DANGER

- Before changing the saw, please make sure if the power is closed to void danger.
- Before changing the saw, please install the protective film to protect the saw and avoid danger while change.

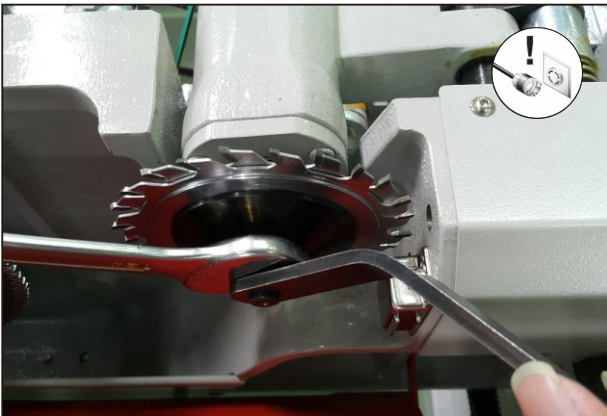

Push the sliding table to the bottom, open the saw blade guard (refer to 2-8 for detailed operation), use the handle to remove the flange fixing nut, clean the flange and new saw blade and then install them back to the scoring saw's arbor.

⚠ DANGER

The flange fixing nut of the scoring saw must be tightened by torque 250kg/cm.

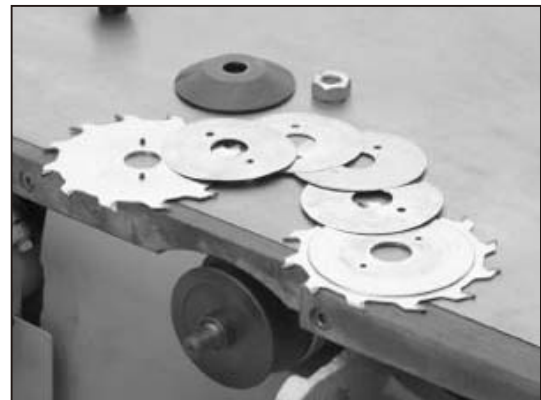

- The cushion in above drawing is used to adjust the cutting width of the scoring saw being bigger than the cutting width of the main saw blade to make the cutting workpiece look nicer.
- Thickness of the attached scoring saw is 2.8mm but it can be adjusted to 4.3mm.
- Cushion's size & quantity :
 - 0.1mm → 1pcs.
 - 0.2mm → 1pcs.
 - 0.3mm → 4pcs.

3-1 POWER CONNECTION**⚠ DANGER**

- Power connection must be done by the qualified electronic engineer.
- The machine must have an earth wire to prevent electric leakage from happening electric shock and even death.

Connect the wiring step :

1. Make sure the voltage of the machine conforms to your company's power.
2. Use the specific tool to open the power controlling box to connect power.
3. Connect three power wires to terminal L1 ,L2 ,L3 as shown in the Fig.1 . Connect the earth wire (green-yellow) to PE terminal.
4. Start motor to check if the rotating direction of the main saw blade and the scoring saw is the same direction as indicated in chapter 1-4.
5. If the saw blade rotates in reverse direction , please stop rotating and shut power off , exchange terminal L1 position for L2 position and

POWER DISTRIBUTION UNIT CE TYPE

Fig.1



Fig.2



Fig.3

⚠ DANGER

The supply cable 3.5 mm² is secured for 25A

OPEN POWER CONTROLLING BOX



Use the specific tools enclosed in the tooling box.

⚠ DANGER

Please make sure the power is turned off before opening the electric cabinet door.

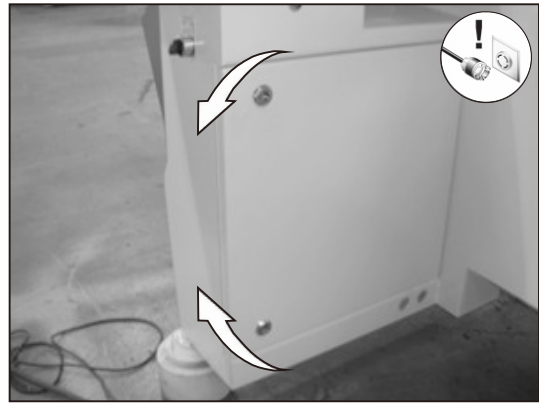

According to the Fig marked direction can be open the electric cabinet door.

Notes for wiring :

1. Power input : AC5V and AC12V / 50~60HZ.
2. Signal input : Standard proximity sensor or encoder A, B phase signal (DC12V)
3. Unit of measurement : Degrees.
4. Don't connect the shielded cable of the induction unit to circuit 0volt or GND.
5. Sensor shielded cable please direct connection to the controller.
6. For reducing controller interference. Please separate signal wire and power wire.
7. The programmable controller is intended of use in Zone B typical industrial environment.

⚠ DANGER

- The fuse in above NO. 6 can't exceed over 3A. Please choose proper fuse by yourself.
- Electrical technician and operator must obey above-mentioned items. If they are freely changed and hence causing controller burnt out or abnormally mechanical damage, the consequence will be borne by yourselves.

3-2 OPERATION OF CONTROL PANEL

EXPLANATION OF MAIN KEYS

Digital display

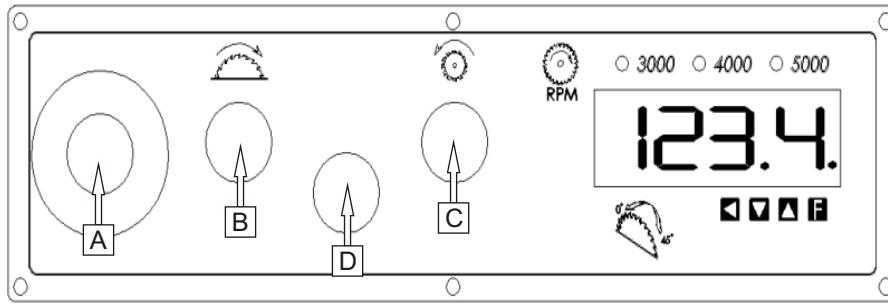

- A. Emergency stop button-----Urgently shut down the machine's power.
- B. Main saw start button----- Start main saw.
- C. Scoring saw start button ----- Start scoring saw.
- D. Saw blade stop button -----Stop the main saw and scoring saw..

EXPLANATION OF ANGLE MACHINE'S KEYS

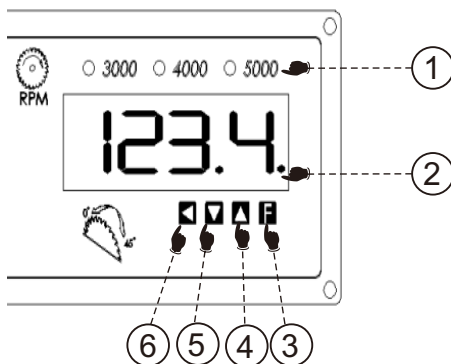

Functions :

1. R.P.M display 3000、4000、5000.
2. 4 Digits display, one decimal point.
3. Set button.
4. Set button.
6. Set button.

Notes for angle screen :

- The angle screen of the machine adopts micro-computer single chip controller, so it's stable and safe under long-term use. Please refer to chapter 3-3 for detailed operation.
- When power is closed, the angle screen doesn't have any display. After power is started, the angle that the angle screen shows is the angle when power was closed last time. After power is closed, please don't adjust the angle and tighten the fixing knob on the hand wheel.
- If the angle is adjusted accidentally while power is closed, please first return angle to zero to avoid the cutting angle and the actual angle being not the same after power is started. Please refer to chapter 3-3 for operation of returning zero.

OPERATING INSTRUCTION FOR CORRECTING CURRENT DIMENSION

Current figure show on the display is 21.5

To correct in 35.1, the steps to operate are as the following diagrams demonstrated.

DIAGRAM.3

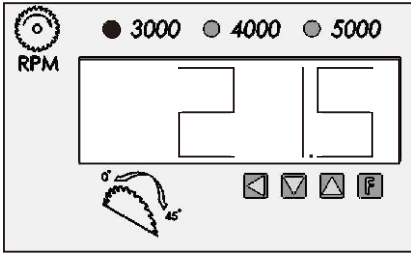

The display shows 21.5

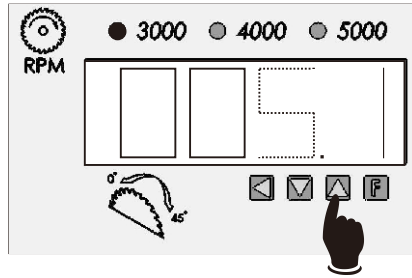

Step 4 : Press ◀ button once and press ▲ button 5 times. The display shows 005.1 and 3th digital (5) flash.

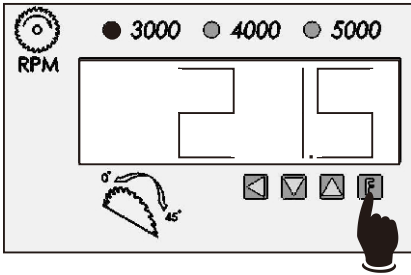

Step 1 : Press button F 2 seconds, unrelease button.

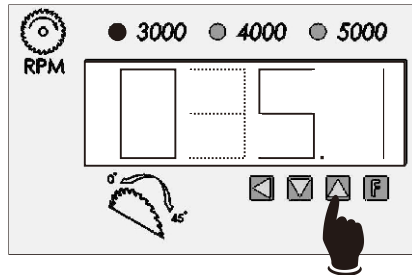

Step 5 : Press ◀ button once and press ▲ button 3 times. The display shows 035.1 and 2th digital (3) flash.

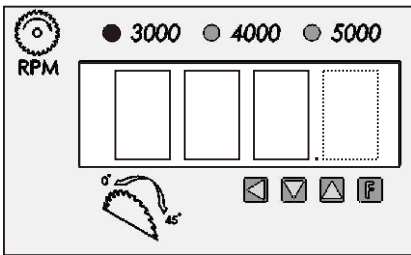

Step 2 : Release button F the display shows 000.0 and 4th digital flash.

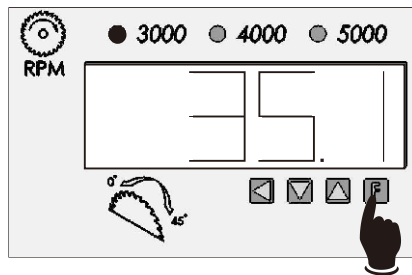

Step 6 : Press F button 2 seconds the display shows 35.1 and stop to flash.

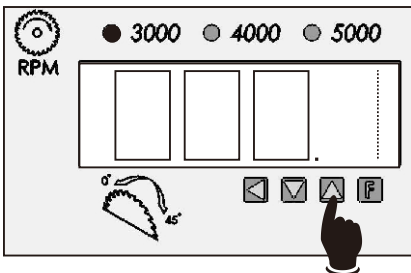

Step 3 : Press button ▲ once the display shows 000.1 and 4th is flash.

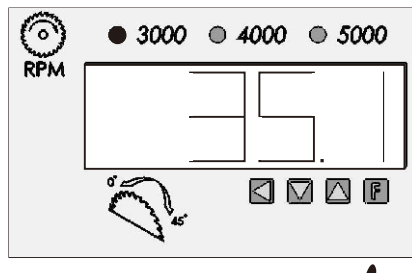

Step7 : Correcting completed.

3-4 5. DESCRIPTION OF PARAMETER SETTING

P2.P3 angle setting .P2 default parameter is 0111 which means 4 digits prior to decimal.P3 default parameter is 8300 which means 4 digits after decimals and therefore , the angle parameter is 0.011183.(should there be deviation for parameter please kindly adjust p3.)

! WARNING

- 1.The operators have to pay their attention not to make any change. Otherwise, the controller is possible to be unusual and damaged the machine, please caution.
- 2.Unless by authorized technicians, do not make any alteration or modification in operating the machinery, so as to avoid machinery operation in incorrect dimensions and to prevent any hazard.
- 3.P2.P3 can be set according to customers need.(please don`t change codes)

Setting for angle parameter :

It the setting is 1000 for P2 , change to 0111; setting for P3 is 0000, change to 8300, please refer to the delow diagram.

DIAGRAM.4

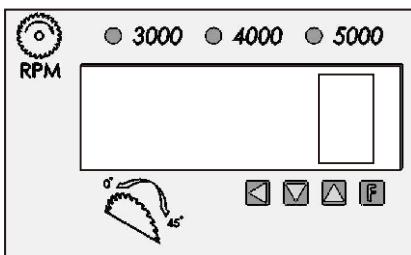

The display shows 21.5

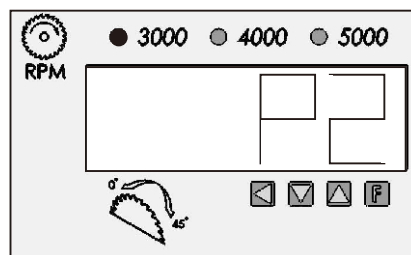

Step 3 :
Press button ▲ or ▼ , The display shows P2.

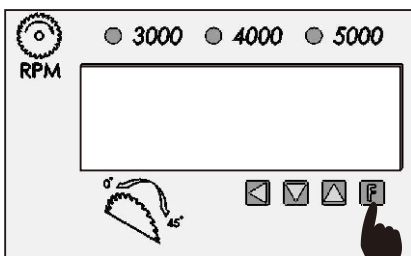

Step 1 :
Turn off the power. Press button F (unrelease button) then turn on the power.

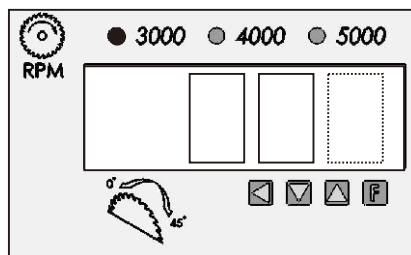

Step 4 :
Press button F , The display shows 100.0 and 4th digital is flashing.

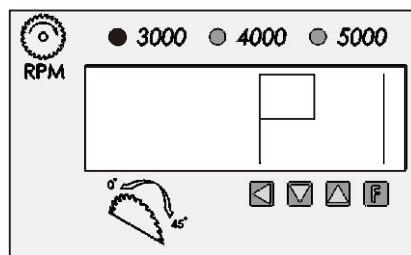

Step 2 :
release button F the display shows P1.

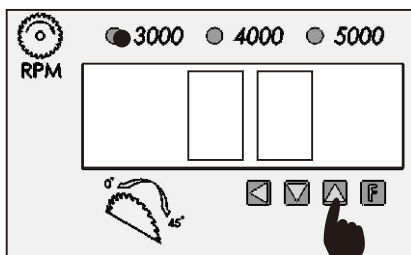

Step 5 :
Press button ▲ once, The display shows 000.1 and 4th digital is flashing.

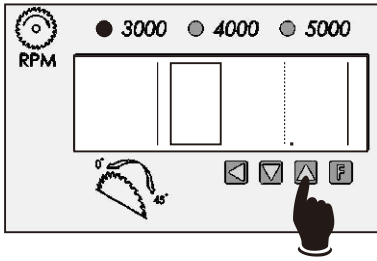

Step 6 :
Press button once and press button once.
The display shows 101.1 and 3th digital (1) flash.

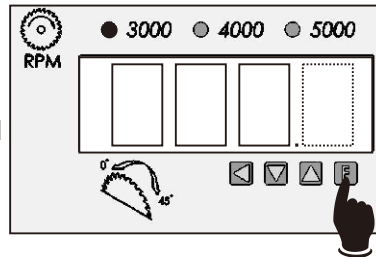

Step 11 :
Press button , The display shows 000.0 and 4th digital is flashing.

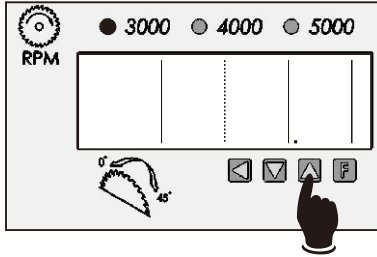

Step 7 :
Press button once and press button once.
The display shows 111.1 and 2th digital (1) flash.

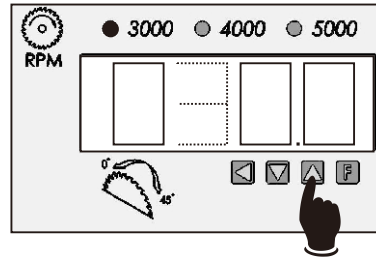

Step 12 :
Press button 2 times and press button 3 times.
The display shows 030.0 and 2th digital (3) flash.

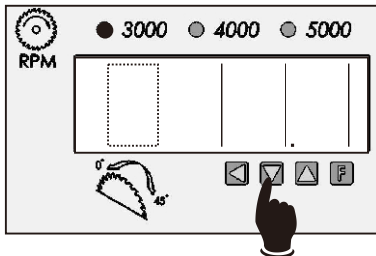

Step 8 :
Press button once and press button once.
The display shows 011.1 and 1th digital (0) flash.

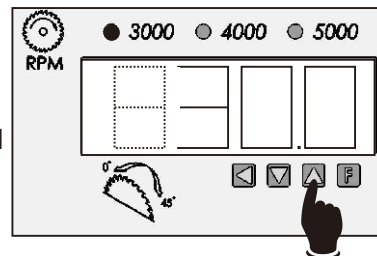

Step 13 :
Press button once and press button 8 times.
The display shows 830.0 and 1th digital (8) flash.

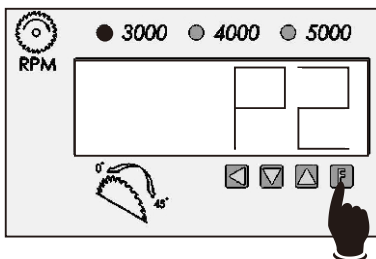

Step 9 :
Press button the display shows P2.

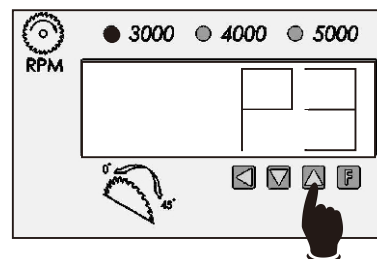

Step 14 :
Press button the display shows P3.

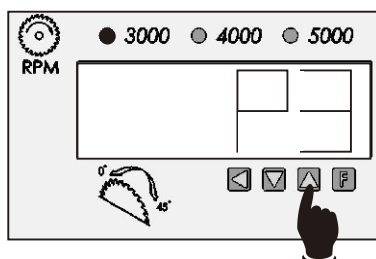

Step 10 :
Press button or , The display shows P3.

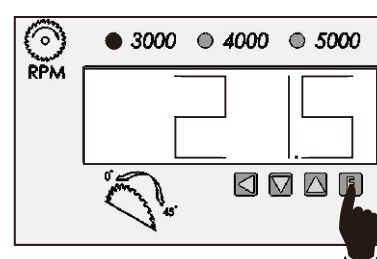

Step 15 :
Press button 2 seconds the display shows 21.5 and stop to flash.

4. CLEAN & MAINTAIN UNIT ▶▶▶

4-1 MAINTENANCE OF THE SLIDING TABLE

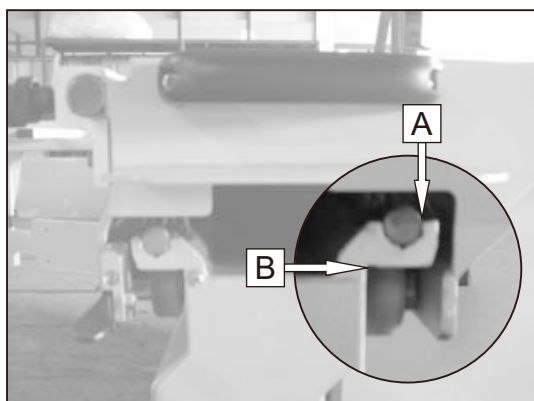

- Clean the contact surface (Surface A) of upper slide base and lower slide base.
- Clean the contact surface (Surface B) of lower slide base and the roller.
- Periodically clean above contact surfaces to keep long-term accuracy of machine.

4-2 MAINTENANCE OF ANGLE SLIDE RAIL

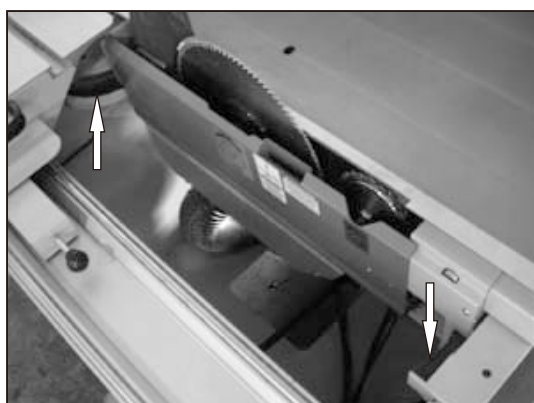

- Clean dust or wood chips on slide rail.
- After cleaning, apply the lubricating oil. Please refer to the following list to choose the lubricating oil.
- Periodically maintain above contact surfaces to keep long-term accuracy of machine.

ISO DIS-3498	LUBRICATING CYCLE	LUBRICATING WAY
XM2	6 months	Lubricate on the machine
BRAND		
MOBIL	ESSO	SHELL
MOBILUX 2	BEACON 2	ALVANIA R2

List 1

4-3 SAFETY CHECK [CE]

WARNING

Do safety check at least twice every week to secure emergency switch's normal function.

CHECK OF EMERGENCY STOP SWITCH

Steps of check :

1. Connect to power, start the main saw blade and the scoring saw to make the machine run.
2. Push each emergency stop of machine and check if the saw blade and the scoring saw completely stop within 7 seconds.
3. When the emergency stop starts, operate the machine to see if it works.

Remarks : When the emergency stop starts, the machine doesn't have any action.

4. If the emergency stop is out of order, please immediately stop operation and respond to the supplier.

CHECK OF SAFETY CONNECTION SWITCH

Steps of check :

1. Connect to power, open safety door (i.e. saw blade's guard and service door at the back of the machine).
2. Operate the machine. At this time, the machine doesn't have any action.
3. Close the safety door and operate the machine again.
4. If machine works normally, that means the safety connection switch is normal.
5. If machine doesn't have any action when the safety door is closed, please stop operation immediately and respond to the supplier.

CHECK OF BRAKE

Steps of check :

1. While the saw blade and the scoring saw are running, push the saw stop switch or the emergency stop switch.
2. At this time, the saw blade and the scoring saw should completely stop within 7 seconds.
3. If the brake time exceeds 7 seconds, please immediately stop operating machine and respond to the supplier.

5.TROUBLE SHOOTING GUIDE ▶▶▶

TROUBLE	CHECK CAUSE	ACTION
1. LED no any display	1. Check if power AC 5V and AC 12V are normal.	Input correct voltage.
	2. If voltage is normal, that means controller is damaged.	Respond to supplier for repairing.
LED's shown 2. value isn't the actual value	1. Check if the shown size is correct.	Correct controller's size as per actual size. Please refer to chapter 3-3 for detailed correction.
	2. Check if parameter is correct.	Respond to supplier to get correct parameter. Please refer to chapter 3-4 for detailed parameter.
LED displays normally but LED 3. value does not react when angle moves.	1. Check if spindle connecting device between encoder and machine comes off or is damaged.	If the spindle connecting device is damaged, please change the encoder.
	2. Use voltmeter to measure if A,B phase have DC 12V and OV reaction.	If A,B phase don't have any reaction, please change encoder.

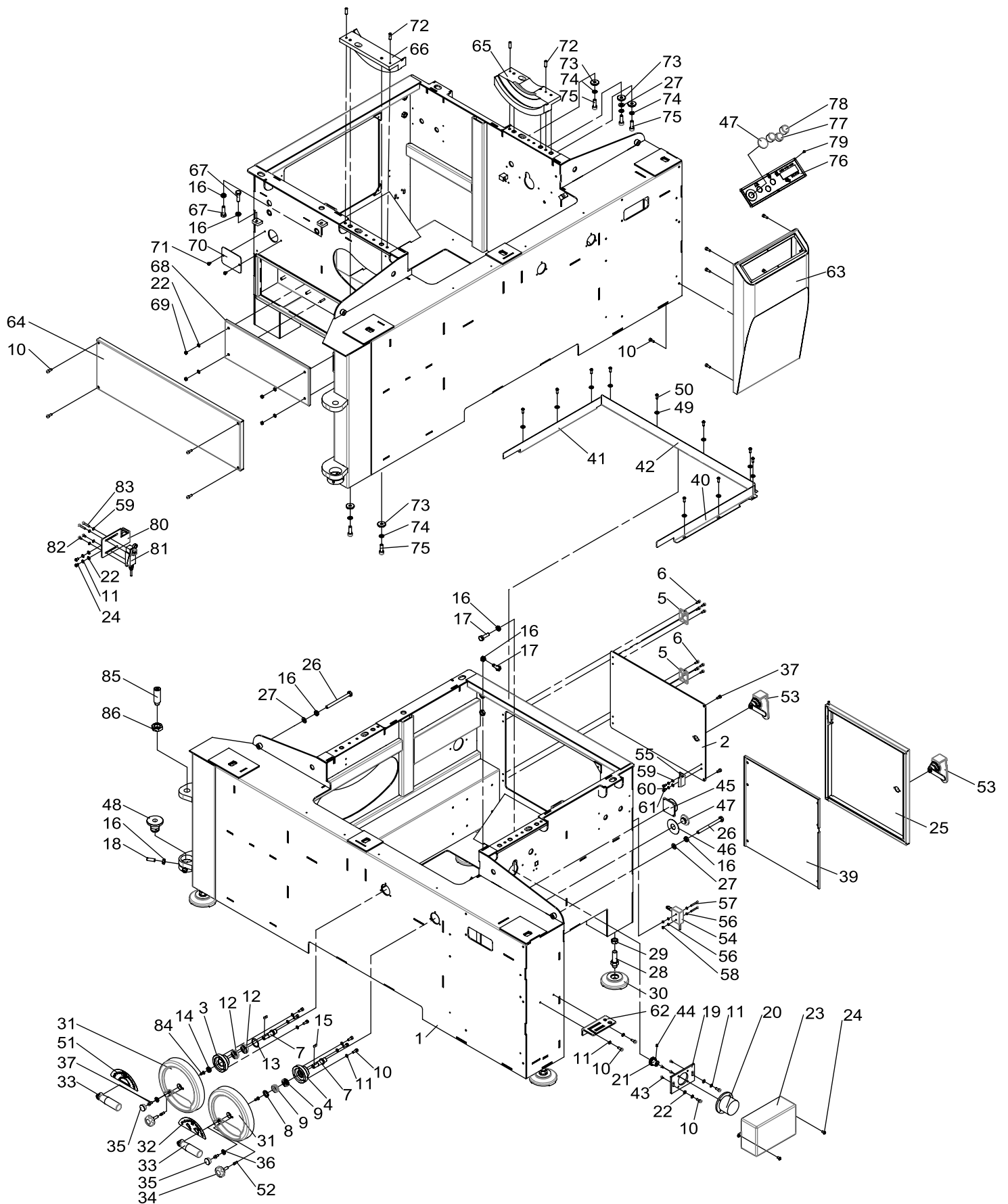

NO	FIG.NO.	DESCRIPTION	SPEC
1	20211001-0	Saw frame body	
2	20211002-0-56	Rear door	
3	20213002-0	Bearing base	
4	20413001-0	Bearing base	
5	402090002	Aluminum Hinges	CL-208
6	401022028	Cap scre	M5x12
7	NST-433-0-0	Shaft	
8	NST-434-0-0	Washer	
9	403060003	Thrust bearing	51102
10	401022053	Cap scre	M6x16
11	401150003	Lock Washer	
12	403017102	Ball Bearing	6002-LLB
13	401251024	C-shaped buckle	RTW-32
14	NST-437-0-0	Washer	
15	401230026	KEY	5x5x16
16	401101006	Hex nut	M10
17	401011014	Hex head bolt	M10x35
18	401072069	Set serew	M10x30
19	ST405-105	Fixed Board	
20	415071113	Encoder	HSK-XA074
21	ST405-104	Gear	
22	401140010	Washer	Ø6
23	ST-C005A	Cover	
24	401032029	Round head scre	M6x10
25	LST-A007E	Electron Door	
26	401010047	Hex bolt	M10x120
27	401140005	Washer	Ø10
28	LST-A017	Levelng pads	
29	401101012	Hex nut	M16
30	401260007	Adjust Base	
31	NST-403-1-0	Handwheels	
32	NST-430-0-0	Mark	
33	402010001	Revolving hadles	
34	402070007	Star Knobs	
35	414080001	Hole plugs	HP-22
36	NST-432-0-0	Washer	
37	401022053	Cap scre	M6x16
38	401010009	Hex Head Bolt	M6x20
39	LST-A010	Electron Part	
40	20211101-0	Shutter	
41	20211102-0	Shutter	
42	20211104-0	Shutter	
43	401042012	Phillips sunk head cap screw	M4x8

NO	FIG.NO.	DESCRIPTION	SPEC
44	401072033	Setscrew	M6X6
45	416010045	Power Switch	ZH-28-2-80-BY
46	LST-A011	Mark	
47	416010046	Emergency button	ZB4-BS844+ZB4-BZ102(1B)
48	20213005-0	Support adjusting baes	
49	401140010	Lock Washer	Ø6x13
50	401032032	Button head scre	M6x16
51	NST-429-0-0	Elevator mark	
52	NST-427-0-0	Set straight	
53	402010025	Handle	JHA-172-2H
54	416040002	Limit switch	TZ-7312
55	20213003-0	Touch block	
56	401140001	Washer	Ø4
57	401042015	Phillips Head Screw	M4x35
58	401101002	Hex nut	M4
59	401140002	Washer	Ø5
60	401150002	Lock Washer	Ø5
61	401022027	Cap scre	M5x10
62	ST-A110	Tool block	
63	20212002-0	Electric control box cover	
64	20212004-0	Electrical box cover	
65	LST-A002A	Right slide base	
66	LST-A003	Left slide base	
67	401010038	Hex Bolt	M10x35
68	20212005-0	Electrical box bottom plate	
69	401101004	Hex nut	M6
70	ST-T047A	Cover	
71	401032029	Round head hex	M6x10
72	401200034	Fixed Ring	
73	RH-2040	Washer	
74	401150005	Lock washer	Ø10
75	401022105	Cap scre	M10x30
76	415012001	Control panel	MH-130
77	416010048	Button, OFF	ZB4-BA4+ZB4-BZ102(1B)
78	416010047	Button, ON	ZB4-BW33+ZB4-BZ101(1A)
79	401032008	Button head serew	M4x8
80	LST-A013	Switch fixing plate	
81	416040005	Micro-motion witch	ME-8104
82	401042008	Phillips Head Serew	M5x10
83	401042105	Phillips sunk head cap screw	M5x30
84	401052131	Counter sunk head cap screw	M6x16
85	20213004-0	Lower positioning shaft	
86	401101010	Hex Nut	M24

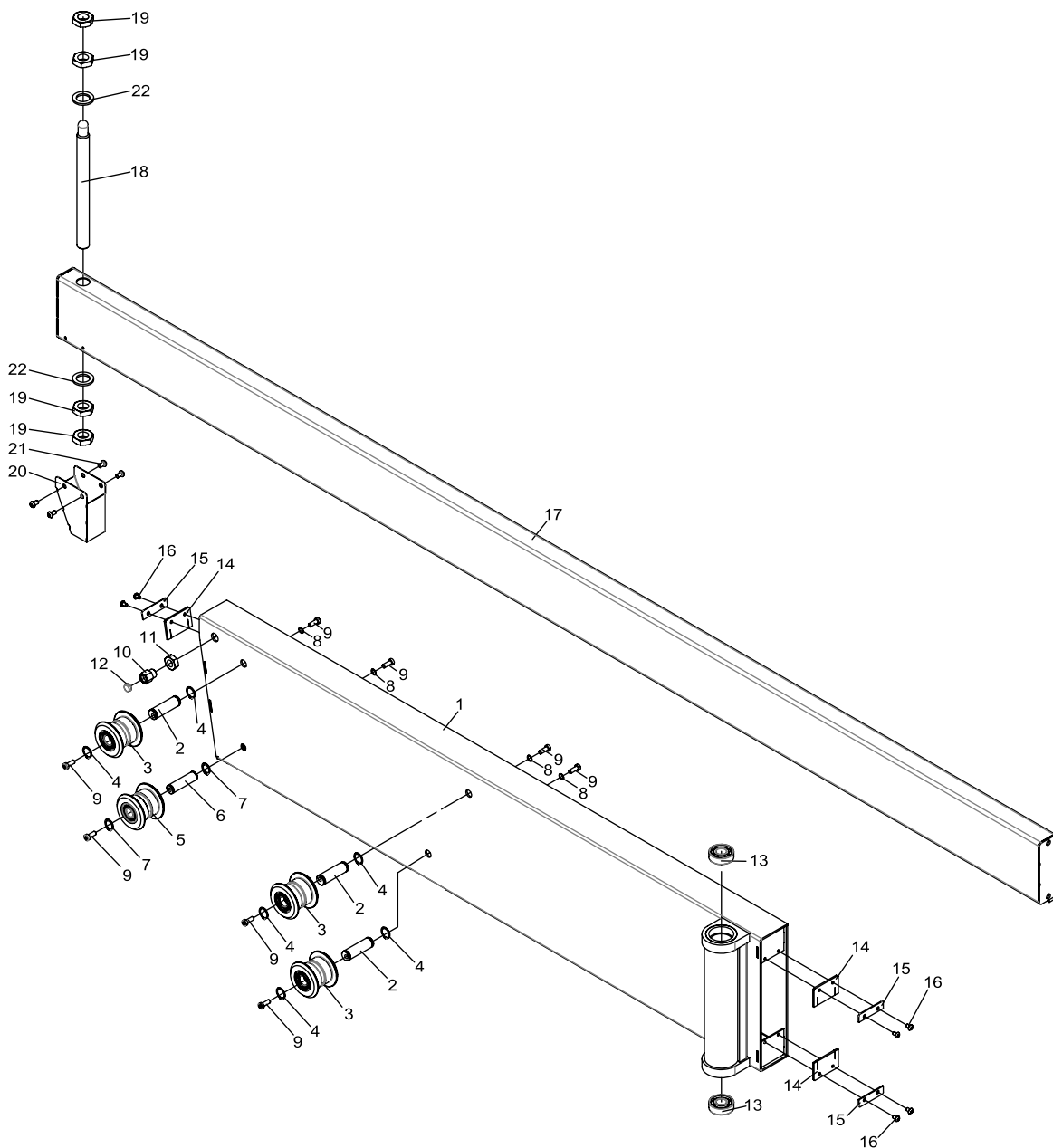

NO	FIG.NO.	DESCRIPTION	SPEC
1	LST-G001G	Crosscut Swing Arm	P26/P32
2	LST-G004	Adjustment shaft	
3	ST-J014K	Roller/Ball bearing	6003-ZZ TPI
4	401252012	Ext Retaining Ring	S-17
5	ST-J014L	Roller/Ball bearing	6202-ZZ TPI
6	ST-J015	Roller for shaft	
7	401252010	Retaining rings for shaft	S-15
8	401151002	Washer	Ø8
9	401212001	Low head cap screw	M8x16
10	LST-A008A	Housing for magnet	
11	401101008	Hex nut	M14

NO	FIG.NO.	DESCRIPTION	SPEC
12	402120001	Magnet	Ø12x5 S03302
13	403015133	Ball Bearing	6203-LLU TPI
14	LST-G003	Way wipers	
15	LST-G002	Locating plate	
16	401032016	Button Head Screw	M5x8
17	LST-G009B	Crosscut Swing Arm Extension(2220mm)	3.2
18	LST-G008	Threaded Shaft	M20xP2.5
19	401102002	Hex nut	M20-9.5t
20	ST-J023B	Cover plate	
21	401032029	Round head screw	M6x10
22	LST-G032	Washer	Ø22-Ø34-3t

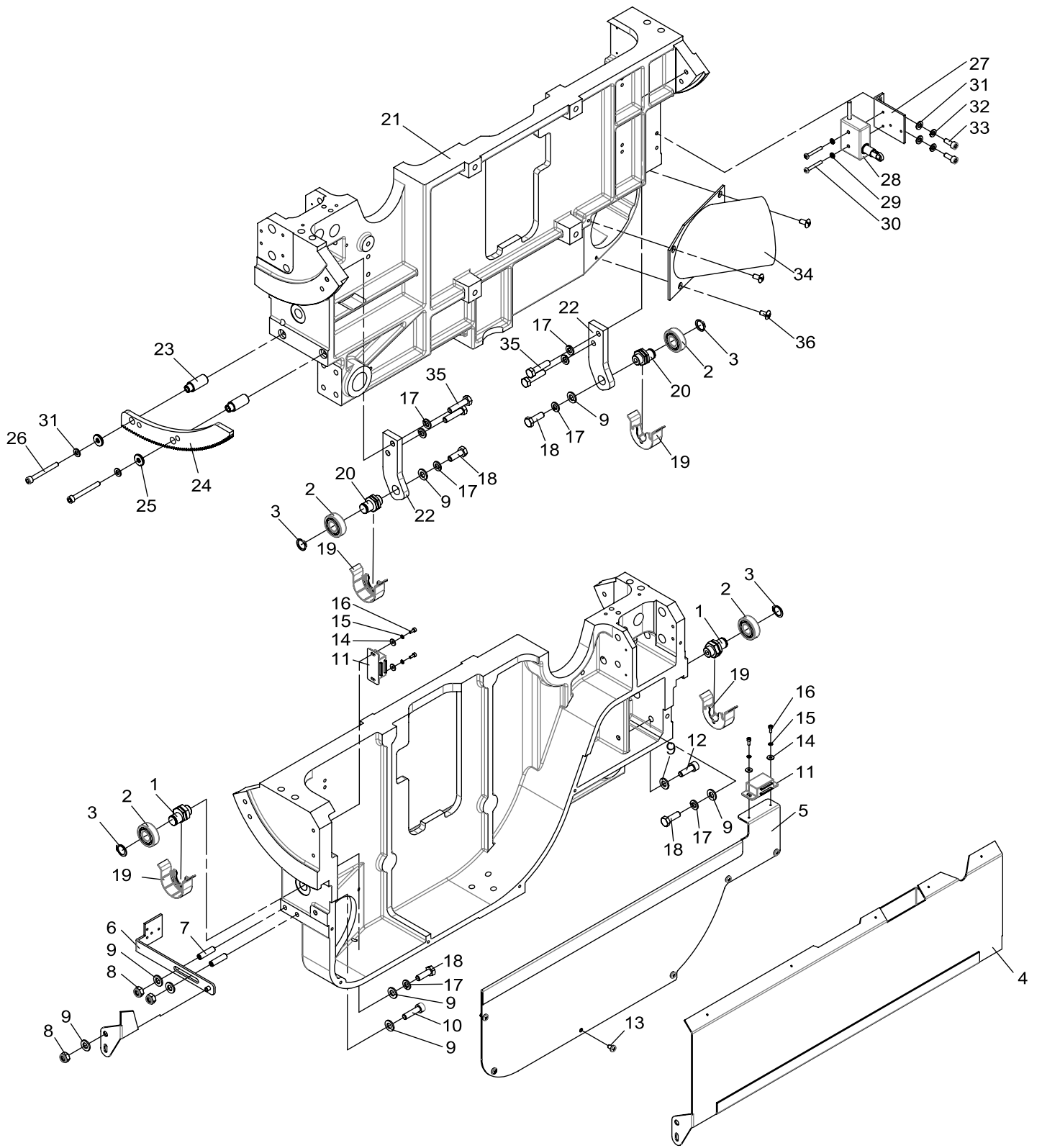

NO	FIG.NO.	DESCRIPTION	SPEC
1	LST-B002	Adjust shaft	
2	403015132	Ball Bearing	6202 ZZ
3	401252010	Retaining rings for shaft	STW-15
4	LST-B009	Cover	
5	20222005-A	Lower blade cover	
6	LST-B013A	Join bar	
7	401072056	Set serew	M8x30
8	401103001	Lock nut	M8
9	401151002	Safety Washer	Ø8
10	401022080	Cap screw	M8x30
11	402120004	Magnets	
12	401022079	Cap Screw	M8x25
13	401042107	Phillips sunk head cap screw	M5x8
14	401140015	Washer	Ø3
15	401150010	Lock washer	Ø3
16	401022002	Cap screw	M3x8
17	401150003	Lock nut	Ø8
18	401010020	Hex Bolt	M8x25

NO	FIG.NO.	DESCRIPTION	SPEC
19	20225001-0	Scraper	
20	LST-B002A	Adjust shaft	
21	LST-B001B	Rotary base	
22	LST-B004	Fixed block	
23	LST-B005	Fixed Pole	
24	LST-B006	Rack	
25	NST-432-0-0	Washer	
26	401022062	Cap Screw	M6x55
27	LST-B014A	Fixed sheet	
28	416040001	Limit switch	TZ7311
29	401140001	Washer,	Ø4
30	401042002	Phlp Hd Scr	M4x30
31	401140010	Washer	Ø6
32	401150003	Lock Washer	Ø6
33	401022053	Cap scre	M6x16
34	LST-B015	Exhaust pipe	
35	401010022	Hex head bolt	M8x35
36	401042101	Phillips Head Screw	M6x12

NO	FIG.NO.	DESCRIPTION	SPEC
1	20234001-A	Riving Knife	
2	20234002-0	Bulletproof claw	
3	20234003-0	Connect film	
4	20234004-0	The rings	
5	401052118	Counter sunk head cap screw	M5x12
6	LST-C001	Spindle Base	
7	20232005-A	Spindle	
8	20232006-A	Spindle flange	
9	20232007-A	Bearing Cover	
10	20232008-0	Spindle pulley	
11	20232012-0	Bearing inner cover	
12	20232013-0	Bearing cap	
13	20232015-0	Bearing cap	
14	20232016-0	Bearing cap	
15	20232016-A	Bearing cap	
16	403010317	Ball bearing	6207 VV CM
17	401110003	Precision nut	YSR-M35x1.5P-L
18	401230021	Key	8x7x40
19	LST-C007	Fixed ring	
20	401230016	Key	8x7x20
21	413101001	PRO-LOCK	
22	404020003	Linear bushing	UB30AWW
23	LST-C009	Dust guard	
24	LST-C010	Riving knife's slide rail	
25	ST-H070	Fixed Sheet	
26	NLST-C055	Riving knife adjusting block	

NO	FIG.NO.	DESCRIPTION	SPEC
27	NLST-C056	Riving knife's front fixed block	
28	NLST-C054	Riving knife's rear fixed block	
29	401200032	Roll Pin	D13x60
30	401022055	Cap scre	M6x20
31	401150003	Lock Washer	Ø6
32	401032029	Round head screw	M6x10
33	401022027	Cap scre	M5x10
34	401010007	Hex head bolt	M6x12
35	401010054	Hex head boit	M12x40
36	401010021	Hex head bolt	M8x10
37	401020030	Cap screw	M5x16
38	401022053	Cap scre	M6x16
39	401101005	Hex nut	M8
40	401150005	Lock washer	Ø10
41	401072035	Set screw	M6x10
42	408020010	Dust ring	
43	401150006	Lock washer	Ø12
44	401022105	Cap scre	M10x30
45	401022032	Cap scre	M5x20
46	410030004	Grease nipples	Straight-1/8"PT
47	401052118	Counter sunk head cap screw	M5x12
48	405150007	Multi-groove skin	6 PK 750
49	LST-B003	Slide rail	
50	401022131	Cap Screw	M12x50
51	401072065	Set Screw	M10x16

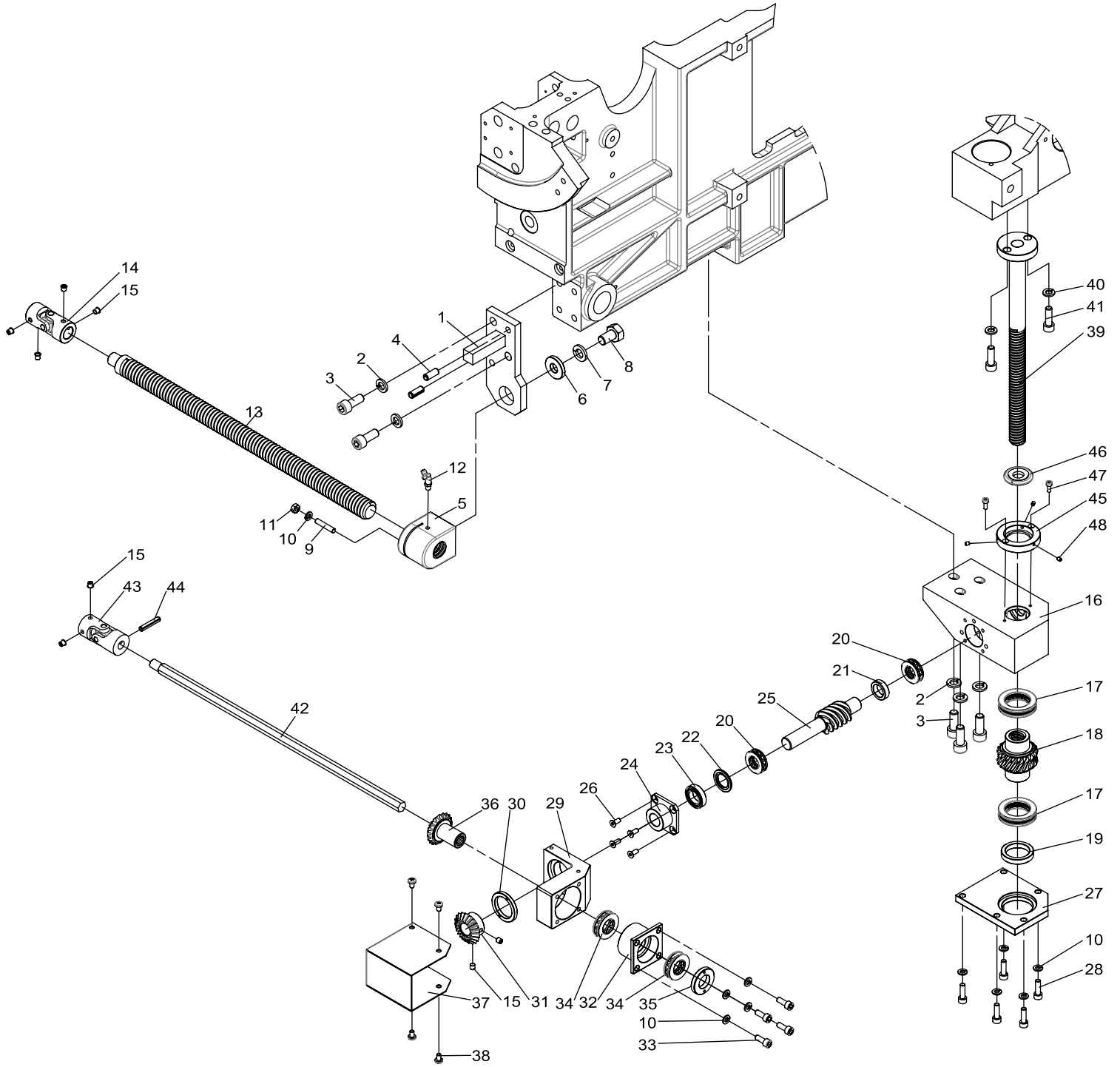

NO	FIG.NO.	DESCRIPTION	SPEC
1	LST-E015	Connecting block	
2	401150005	Lock washer	Ø10
3	401022104	Cap screw	M10x25
4	401200015	Fixed Ring	Ø8x20
5	NST-406-1-0	Nut	
6	RS-3021	Washer	
7	401150006	Lock washer	Ø12
8	401011019	Hex Head Bolt	M12x20
9	401072042	Set Screw	M6x30
10	401150003	Lock Washer	Ø6
11	401101004	Hex Nut	M6
12	410030002	Grease nipples	M6-45
13	NST-401-0-0	Screw	
14	NST-404-0-0	Universal joint	
15	401072033	Setscrew	M6X6
16	LST-E002	Gear hous	
17	403060009	Thrust Bearing	51106
18	LST-E003	Worm gear	
19	LST-E005	Adjustment nut	
20	403060002	Thrust Bearing	51103
21	NST-414-0-0	Collars	
22	LST-E007	Washer	
23	403017235	Ball Bearing	6903LLB
24	LST-E008	Gear hous bracket	

NO	FIG.NO.	DESCRIPTION	SPEC
25	LST-E006	Worm shaft	
26	401052118	Counter sunk head cap screw	M5x12
27	LST-E004	Cover	
28	401022055	Cap screw	M6X20
29	LST-E009A	Housing	
30	LST-E010	Adjustment nut	
31	LST-E011	Bevel gear	
32	LST-E016	Bearing with housing	
33	401022053	Cap screw	M6x16
34	403060001	Thrust Bearing	51104
35	LST-E017	Nut	
36	LST-E012A	Bevel gear	
37	LST-E013A	Cover	
38	401042107	Phillips sunk head cap screw	M5x8
39	LST-E014	Screw	
40	401150003	Lock nut	Ø8
41	401022079	Cap Screw	M8x25
42	LST-E001A	Hex material	
43	LST-E018	Universal joint	
44	401200019	Spring pin	Ø6x32
45	20223003-0	Brush holder	
46	20223002-0	Dust brush	
47	401022013	Cap screw	M4x10
48	401071013	Set screw	M4x5

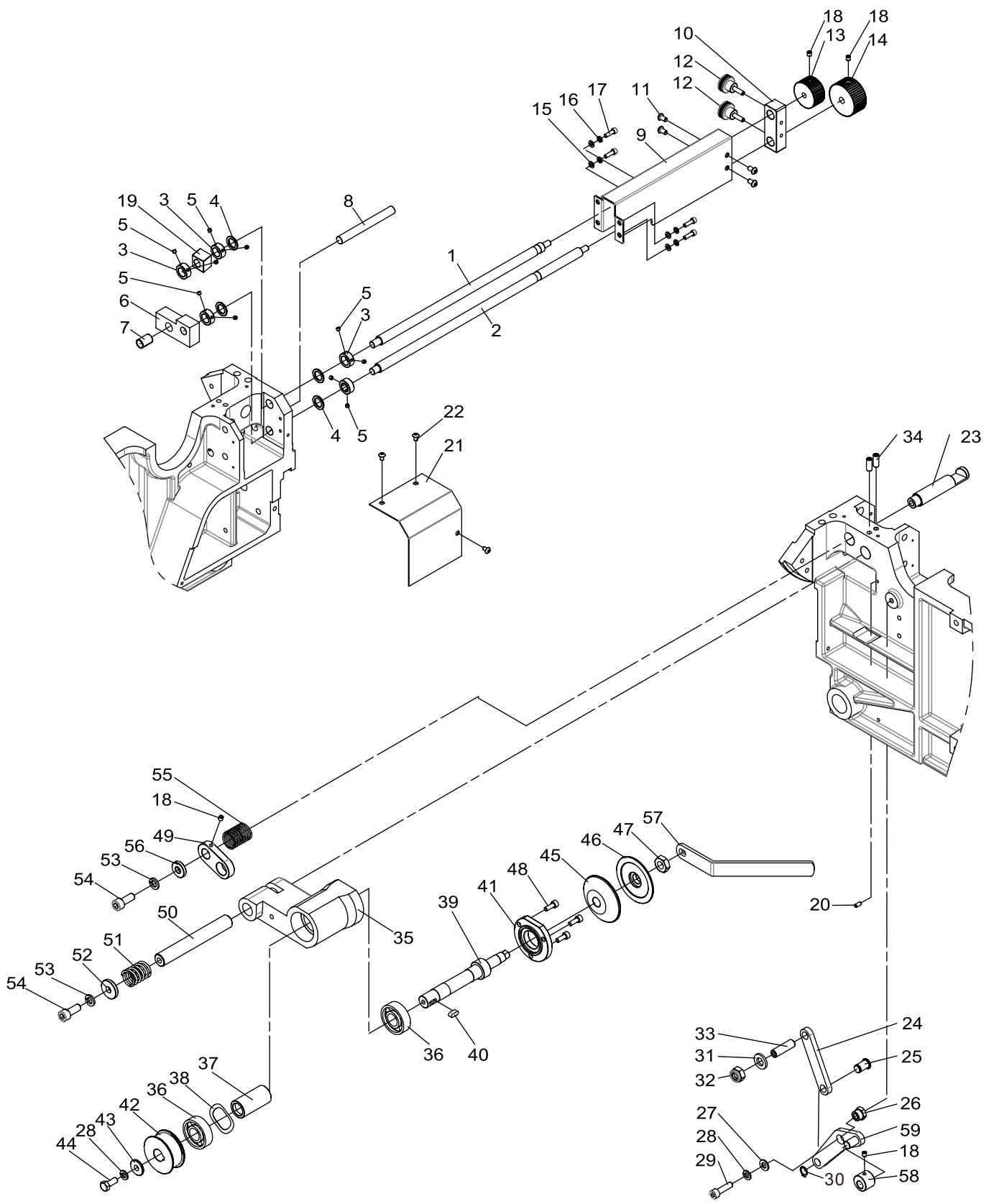

NO	FIG.NO.	DESCRIPTION	SPEC
1	LST-D008A	Adjustment shaft	
2	LST-D010A	Adjustment shaft	
3	LST-D014	Sleeve ring	
4	LST-D017A	Washer	
5	401072136	Set Serew	M5x4
6	LST-D022A	Caterpillar block	
7	403090016	Bush	MB1220
8	LST-D023	Guide	
9	LST-D019A	Block	
10	LST-D020A	Lock block	
11	401032029	Round head screw	M6x10
12	402100004	Embossing screw	8010-25-M6-20
13	402080007	Control knobs	7021-42-B8
14	402080008	Control knobs	7021-52-B8
15	401140023	Washer	Ø5
16	401150002	Lock Washer	Ø5
17	401020030	Cap screw	M5x16
18	401072033	Setscrew	M6X6
19	LST-D009	Caterpillar block	
20	401071025	Set serew	M5x10
21	LST-B010	Cover	
22	401032016	Button Head Serew	M5x8
23	LST-B007	Shaft	
24	NST-314-0-0	Links	
25	NST-315-0-0	Pivot axis	
26	NST-317-0-0	Pivot axis	
27	401140016	Washer	Ø8
28	401150004	Lock nut	Ø8
29	401022080	Cap screw	M8x30
30	401252007	Retain Ring	S12
31	401140014	Washer	Ø12

NO	FIG.NO.	DESCRIPTION	SPEC
32	401103003	Lock nut	M12
33	401072083	Set screw	M12x40
34	401072054	Set screw	M8x20
35	LST-D001	Scoring Spindle Housing	
36	403010305	Ball Bearing	6204-LLB-CM
37	LST-D003	Splndle Sleeve	
38	411050001	Wave washer	
39	LST-D002	Scoring Blade Spindle	
40	401230006	Key	6x6x15
41	NST-321-0-0	Bearing's front cover	
42	ST-I048C	Pulley	
43	ST-I039A	Fixing Ring	
44	ST-I038A	Left hex head bolt	
45	ST-I046	Rear cover	Ø22-t13
	ST-I046A	Rear cover	Ø19.05-t13
	ST-I046B	Rear cover	Ø22-t15
	ST-I046C	Rear cover	Ø20-t13
46	ST-I047	Front cover	
47	401102008	Hex nut	M14-8t
48	401022053	Cap scre	M6x16
49	LST-B008	Links	
50	LST-D004	Arbor Mount Shaft	
51	LST-D034	Spring	
52	RH-2040	Washer	
53	401150005	Lock washer	Ø10
54	401022104	Cap screw	M10x25
55	LST-D024	Spring	
56	LST-D006	Washer	
57	ST-I058	Scoring Blade Wrench	
58	NST-328-0-0	Adjustment collars	
59	LST-D018B	Elbow	

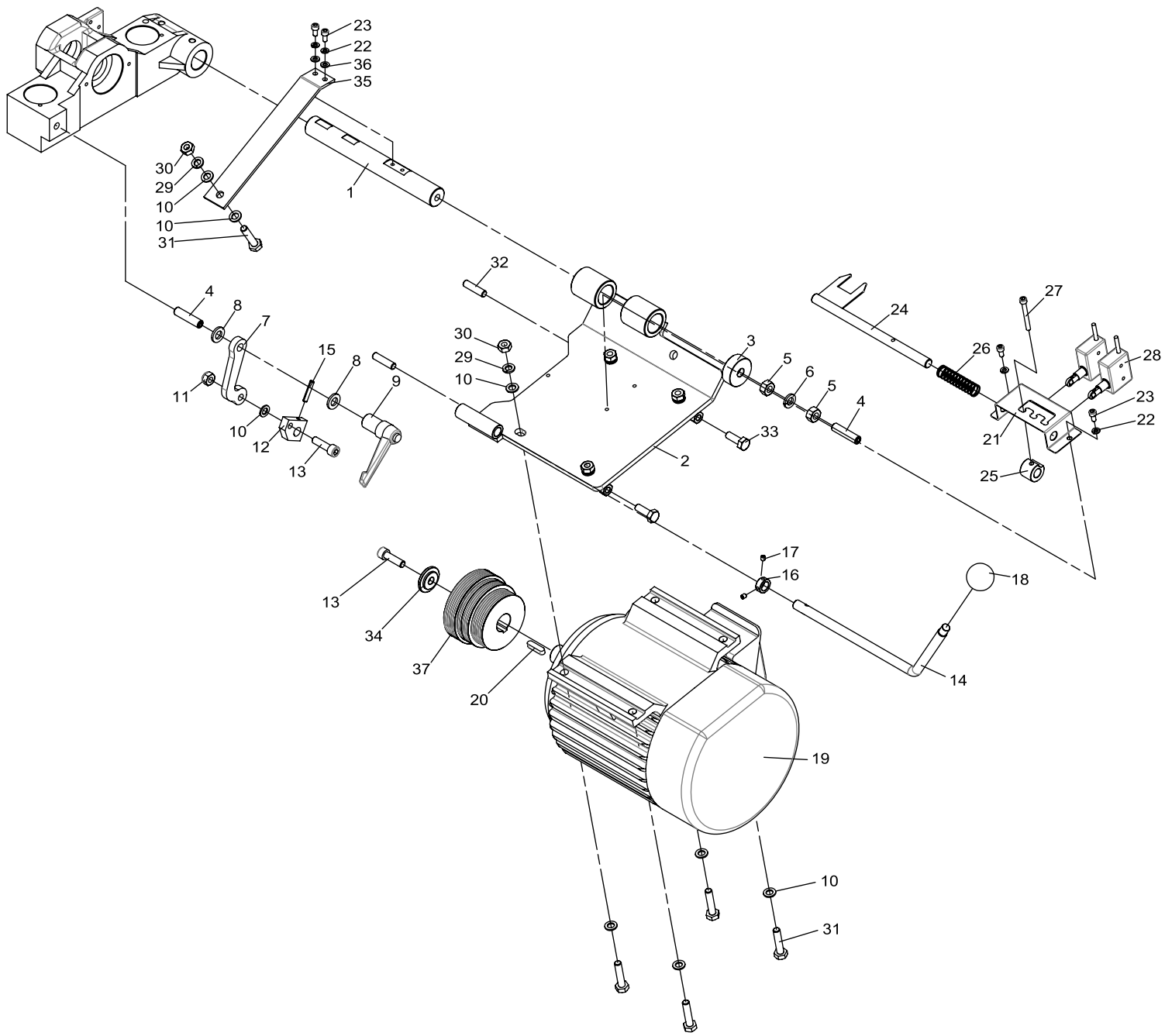

NO	FIG.NO.	DESCRIPTION	SPEC
1	LST-C015A	Shaft	
2	LST-C016A	Main Motor Pivot Plate	
3	LST-C033	End caps	
4	401072085	Sew serew	M12x50
5	401101007	Hex Nut	M12
6	401150006	Lock washer	Ø12
7	LST-C018	Elbow	
8	401140014	Washer	
9	402040024	Adjustable handle	92KA-M12-O
10	401140005	Washer	Ø10
11	401103002	Lock Nut	M10
12	LST-C019	Rotary Block	
13	401022106	Cap Screw	M10x35
14	LST-C020	Adjust Handle	
15	401200019	Spring pin	Ø6x32
16	LST-D014	Sleeve ring	
17	401072033	Setscrew	M6X6
18	402060006	Knob	1/2"
19		Motor	

NO	FIG.NO.	DESCRIPTION	SPEC
20	401230005	Key	8x7x32
21	20233011-0	Inspection seat	
22	401150003	Lock Washer	Ø6
23	401022051	Cap scre	M6x12
24	20233012-0	Belt position detector plate	
25	LST-C040	Sensing Block	
26	LST-C041	Compressed Spring	
27	401022062	Cap Screw	M6x55
28	416040001	Limit Switch	TZ7311
29	401150005	Lock washer	Ø10
30	401101006	Hex head bolt	M10
31	401010039	Hex Bolt	M10x40
32	401071071	Set screw	M10x40
33	401010037	Hex Bolt	M10x30
34	LST-C007	Fixed Ring	
35	LST-C026	Spring Sheet	
36	401140010	Washer	Ø6
37	20232022-A	Multi-slot pulley	

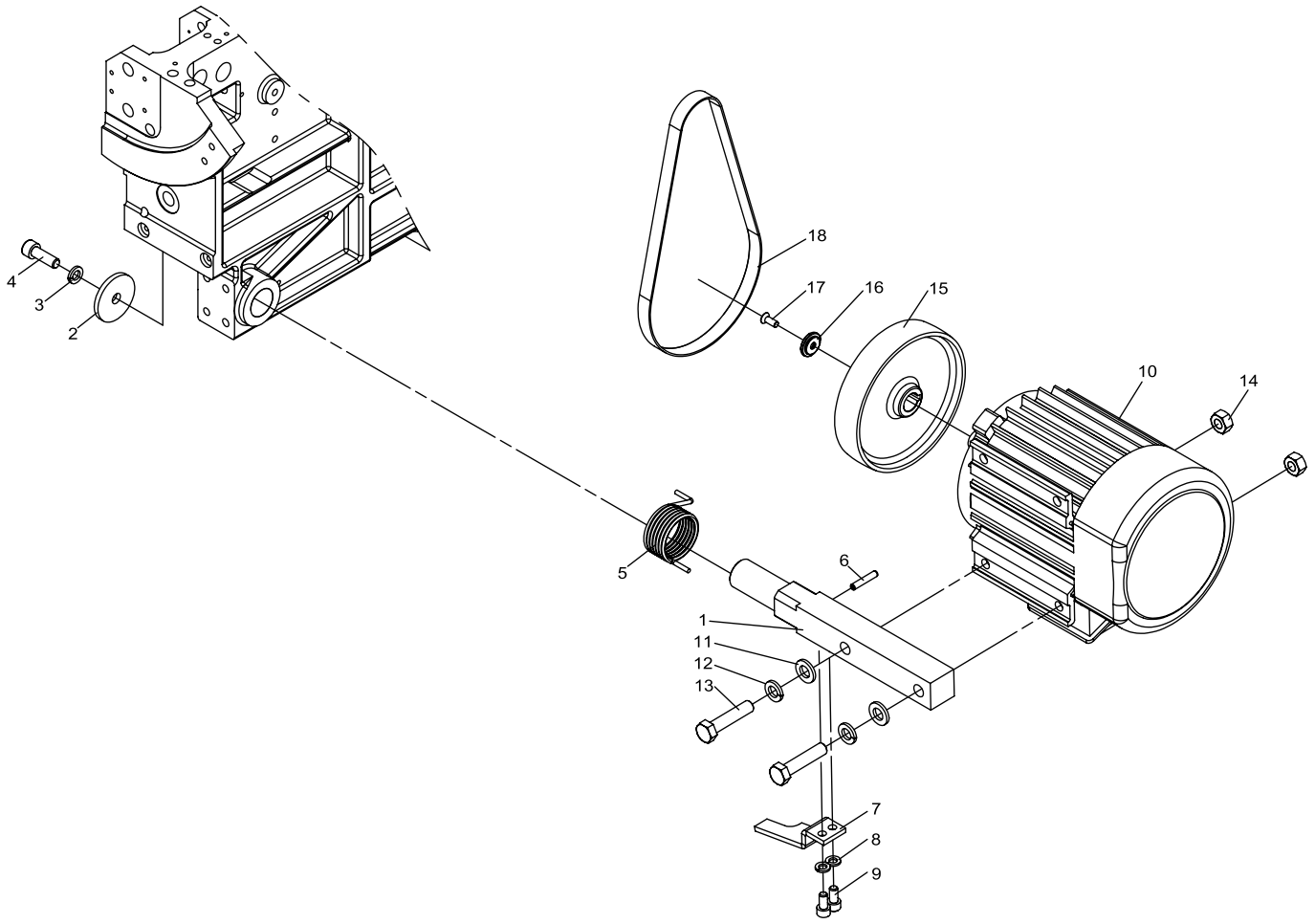

NO	FIG.NO.	DESCRIP TION	SPEC
1	LST-D005	Pivot axis	
2	LST-D007A	Washer	
3	401150005	Lock Washer	Ø10
4	401022105	Cap scre	M10x30
5	NST-104-0-0	Spring	
6	401200019	Spring pin	Ø6x32
7	LST-D025	Stop Board	
8	401150003	Lock nut	Ø8
9	401022076	Cap Screw	M8x16

NO	FIG.NO.	DESCRIP TION	SPEC
10		Motor	
11	401140014	Washer	Ø12
12	401150006	Lock Washer	Ø12
13	401011023	Hex Bolt	M12x55
14	401101007	Hex Nut	M12
15	ST-I032	Pulley	
16	ST-I040	Lock Ring	
17	401052131	Counter sunk head cap screw	M6x16
18	405040006	Belt	15x670x1.8t

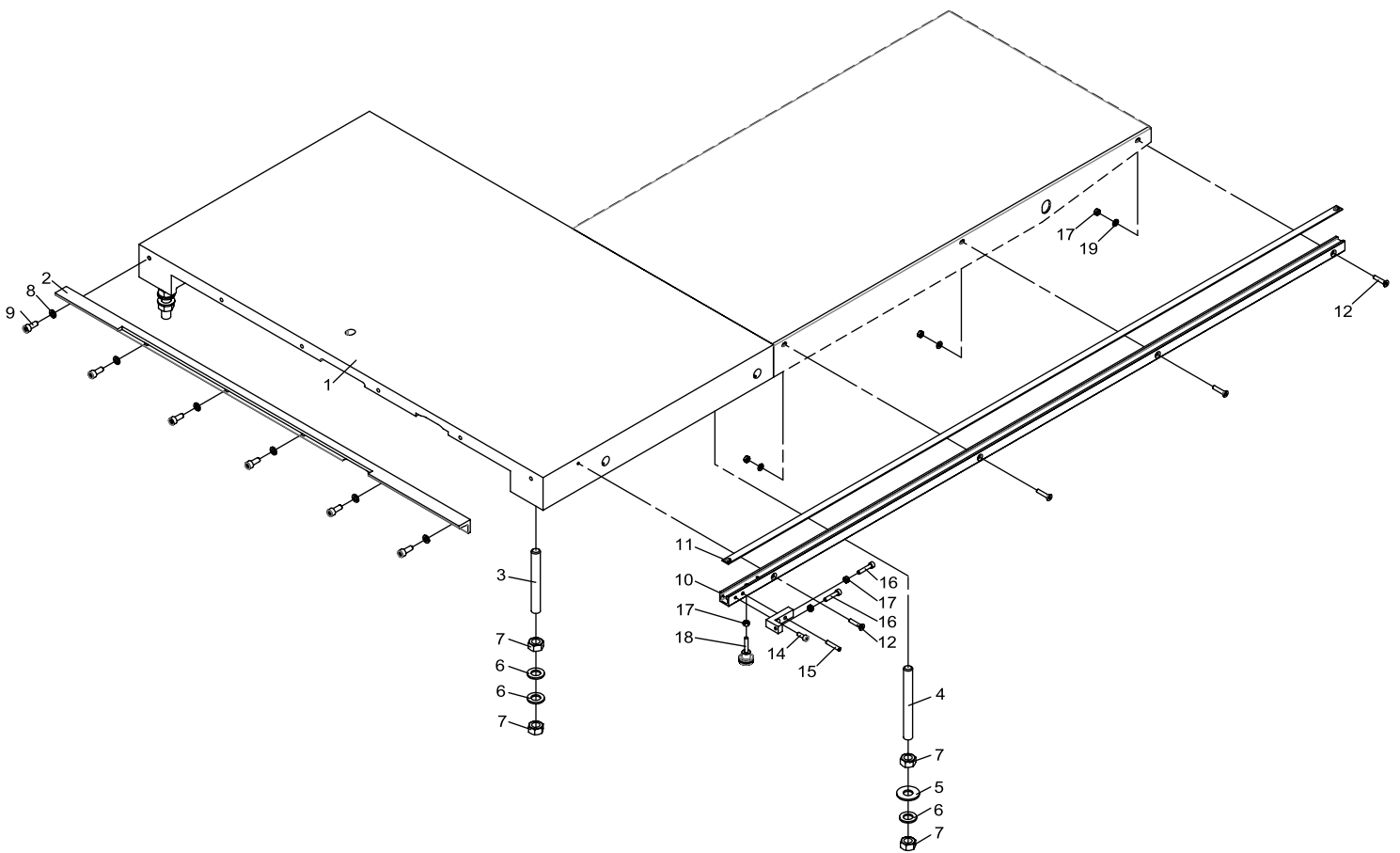

NO	FIG.NO.	DESCRIPTION	SPEC
1	LST-F001G	Main Table	Model 350
2	LST-F003A	Table Insert	
3	401072135	Set screw	M16x130
4	401071131	Set Screw	M16x150
5	401140007	Washer	Ø16x40
6	401140020	Washer	
7	401101012	Hex Nut	M16
8	401150003	Lock nut	Ø8
9	401080012	Hex head bolt	M8x15
10	ST-O016A	Scale base	1.3m

NO	FIG.NO.	DESCRIPTION	SPEC
11	ST-N436	Rip Fence Scale	1.3m · 1.5m
12	401052134	Counter sunk head cap screw	M6x30
13	ST-O026	Scale base rubber guide	
14	401022053	Cap scre	M6x16
15	401200019	Spring pin	Ø6x32
16	401022057	Cap screw	M6x30
17	401101004	Hex Nut	M6
18	402100001	Embossing screw	8010-25-M6-30
19	401140010	Washer	Ø6
20	401072035	Set screw	M6x10

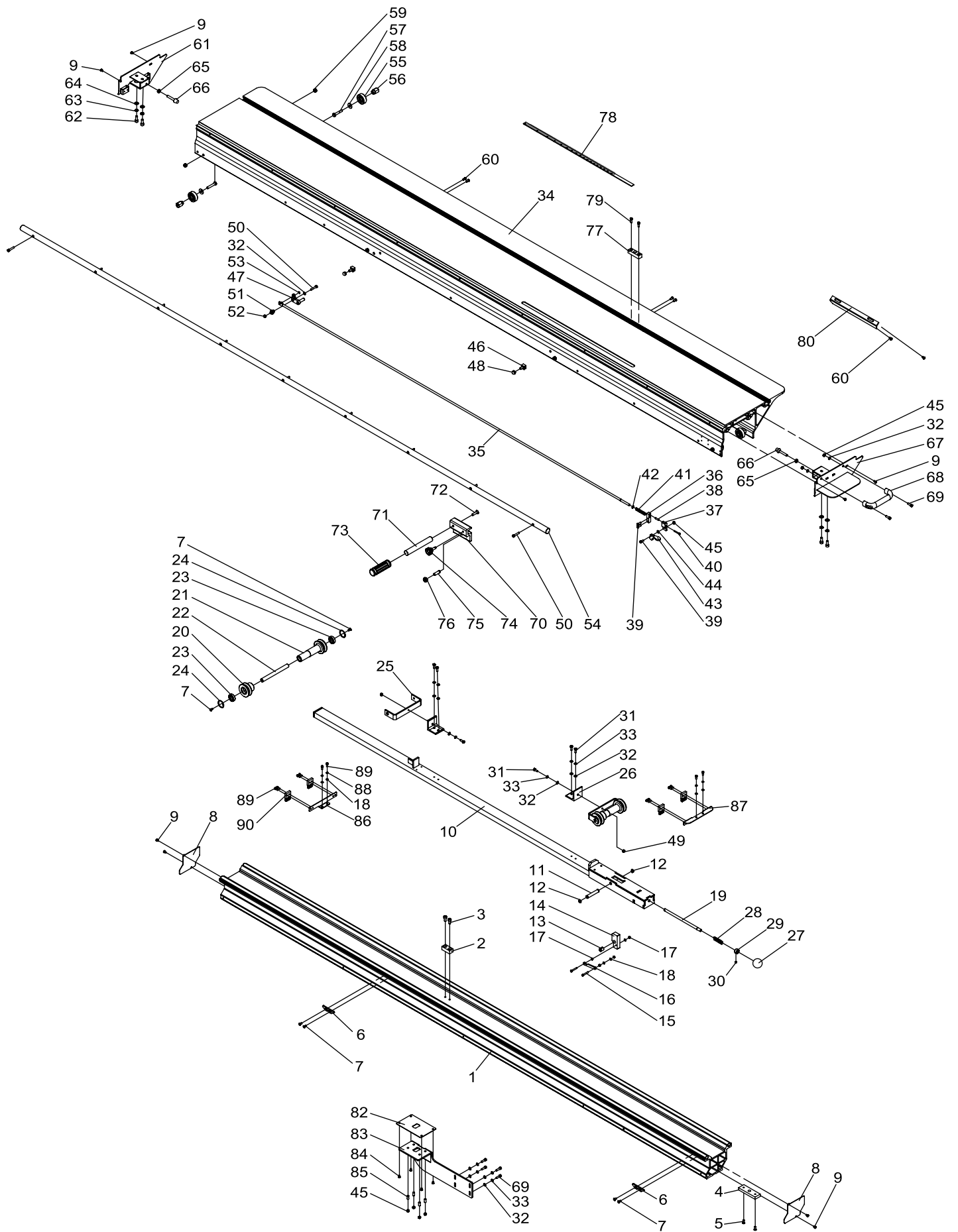

NO	FIG.NO.	DESCRIPTION	SPEC
1	ST-K302G	Support Base	3.2
2	ST-K041A	Stop block	
3	401022076	Cap screw	M8-16
4	ST-K002	Lock Block	
5	401052131	Counter sunk head cap screw	M6x16
6	ST-K316	Positioning block	
7	401052129	Counter sunk head cap screw	M6x12
8	ST-K320	Cover	
9	401042107	Phillips sunk head cap screw	M5x8
10	20261033-0	Slide Bar	3.2
11	ST-K071	Fixed Shaft	
12	401252007	Retain Ring	S12
13	403090013	Bush	LFB1215
14	ST-K069A	Stop Block	
15	401022034	Cap screw	M5x30
16	ST-K073	Join element	
17	401101003	Hex Nut	M5
18	401140002	Washer	Ø5
19	ST-K080	Pull bar	
20	ST-K095	Sliding wheel	
21	ST-K094	Slide Wheel	
22	ST-K096	Slide Wheel Shaft	
23	403017102	Ball bearing	6002LLB
24	401251024	Retaining rings for hole	R32
25	ST-K097A	Slide Wheel Base	
26	ST-K098A	Fixed Base	
27	402060005	Knob	
28	ST-K082	Spring	
29	ST-K083	Fixing ring	
30	401072033	Set Screw	M6X6mm
31	401010008	Hex head bolt	M6x16
32	401140010	Washer	Ø6
33	401150003	Lock Washer	Ø6
34	ST-K301B	Slide Table	3.2
35	ST-K323A	Connect Block	3.2
36	ST-K309A	Fixed Block	
37	ST-K308A	Stop block	
38	401200001	Spring Pin	Ø50x20
39	401032032	Button head screw	M6x16
40	401021020	Cap screw	M4x30
41	ST-K317	Spring	
42	401253012	Retaining Rings E Type	E6
43	ST-K307A	Handle	
44	ST-K322	Washer	
45	401101004	Hex Nut	M6

NO	FIG.NO.	DESCRIPTION	SPEC
46	ST-311	Fixed Pillar	
47	ST-K313A	Connect Block	
48	401104003	Cap Nup	M8
49	401103005	Lock Nut	M6
50	401022057	Cap screw	M6x30
51	ST-K312	Pivot Axis	
52	401104004	Cap Nut	M6
53	401253009	Retaining Rings E Type	E4
54	ST-K204	Slide Rall	3.2
55	ST-K043A	Sliding Wheel	
56	ST-K044	Adjust Block	
57	401010025	Hex head bolt	M8x45
58	401140028	Washer	8x23x3t
59	401103001	Lock nut	M8
60	401032030	Button Head serew	M6x12
61	ST-306	Cover	
62	401022078	Cap scre	M8x20
63	401151002	Spring washer	Ø8
64	401140004	Washer	Ø8
65	401101005	Hex Head Bolt	M8
66	402160002	Stop block	
67	ST-K305	Cover	
68	402020001	Handle	
69	401022055	Cap scre	M6x20
70	ST-K003A	Fixed Block	
71	ST-K004	Handle	
72	401052143	Counter sunk hear cap screw	M8x25
73	402010011	Handle sleeve	
74	402100002	Emboss sscrew	8010-30-M8-20
75	RS-4025	Screw	
76	401101006	Hex head bolt	M10
77	ST-L007	Positioning block	
78	ST-K010	Scale	
79	401022053	Cap scre	M6x16
80	ST-K318	Touch Block	
81	ST-K207	Support Stand	
82	LST-A052	Extended bracket spacer	
83	LST-A051	Extension bracket	
84	401032016	Button Head Serew	M5x8
85	401072052	Set screw	M8x16
86	20261031-0	Brush rack	
87	20261032-0	Brush rack	
88	401150002	Lock Washer	Ø5
89	401022028	Cap scre	M5x12
90	ST-K031B	Bristle brush	

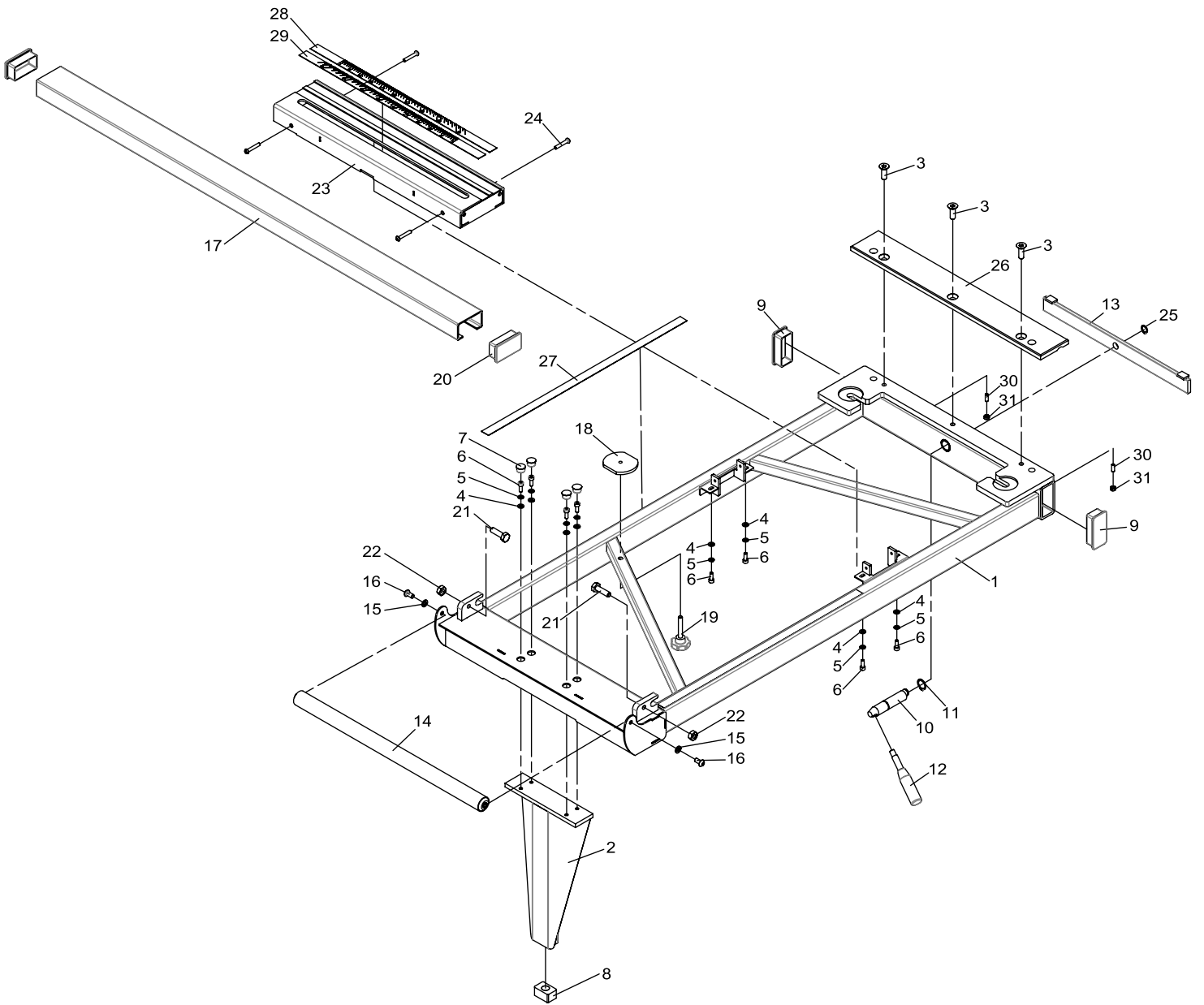

NO	FIG.NO.	DESCRIPTION	SPEC
1	20274005-0	Crosscut table	
2	LST-G027	Support frame	
3	401052152	Counter sunk head cap screw	M10x25
4	401140010	Washer	Ø6
5	401150003	Lock Washer	Ø6
6	401022053	Cap scre	M6x16
7	414080004	Hole plugs	HP-16
8	NST-713-0-0	Rubber guide	
9	ST-M037	Caps	80-40-4t
10	ST-M005	Fixed Shaft	
11	401252015	Retaining rings for shaft	S20
12	402010002	Round Knob	7108-M10-100
13	ST-M006	Lock Bar	
14	403140001	Roller element	U-318SC-RL524-12 M8x20
15	401150004	Lock Washer	Ø8
16	401032043	Button Head Screw	M8x16

NO	FIG.NO.	DESCRIPTION	SPEC
17	ST-M019	Long cross-support	
18	ST-M020	Clampingn element	
19	402070005	Knob bolt	HS50AM850
20	ST-M017	Square tube plug	70x40x3t
21	401010038	Hex Bolt	M10x35
22	401101006	Hex head bolt	M10
23	20274004-0	Scale seat	
24	401032036	Button head screw	M6x35
25	401252009	Retaing rings for shaft	STW-14
26	ST-M002C	Fixed Board	
27	ST-N095G	Avert Friction Sheet	
28	20274002-0	Scale	
29	20274003-0	Scale	
30	401072038	Set Screw	M6x16
31	401101004	Hex Nut	M6

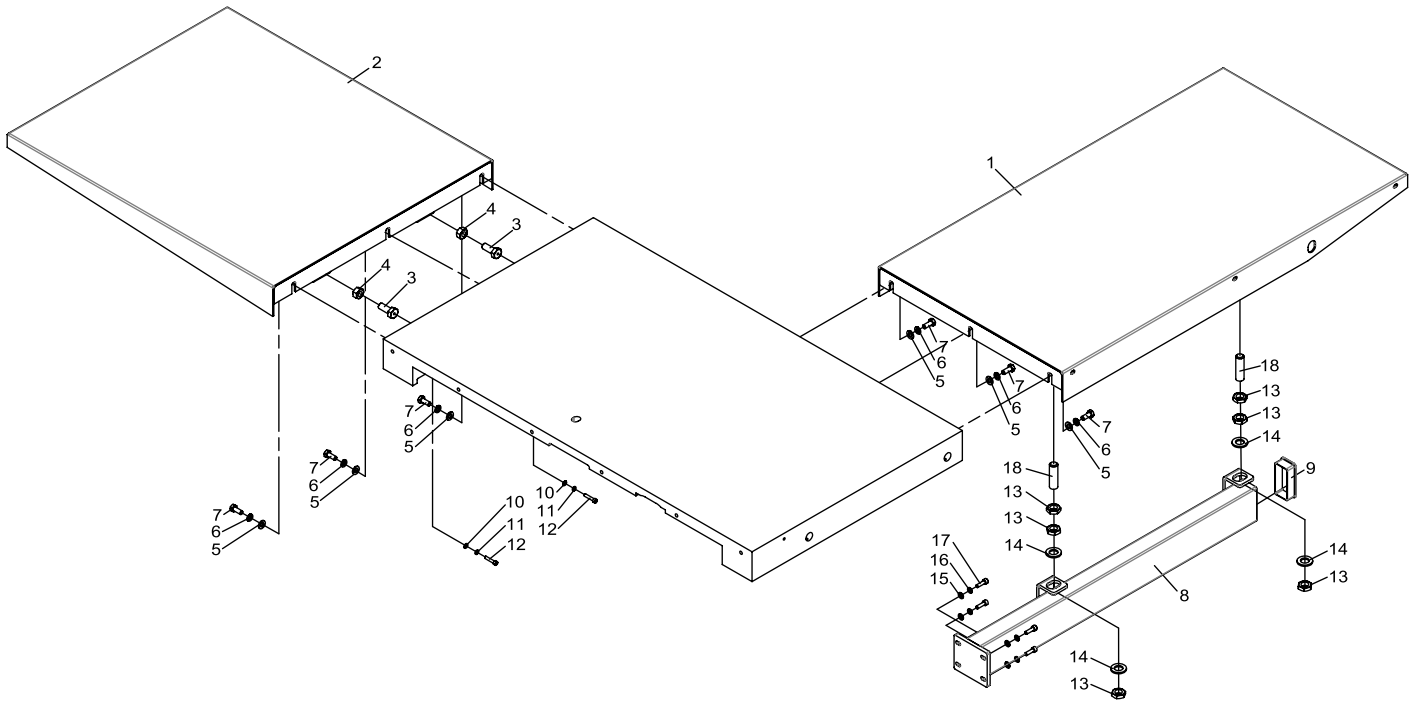

NO	FIG.NO.	DESCRIPTION	SPEC
1	LST-F014B	Width extension	1.3m
2	LST-F011	Small Extension Table	
3	ST405-505	Hex screw	
4	401101007	Hex Nut	M12
5	401151002	Safety Washer	Ø8
6	401150003	Lock nut	Ø8
7	401010019	Hex Head Bolt	M8x20
8	LST-F015A	Support rack	1.3m/1.5m
9	402130001	Square pipe plug	80-40-3t

NO	FIG.NO.	DESCRIPTION	SPEC
10	401140002	Washer	Ø5
11	401150002	Lock Washer	Ø5
12	401022033	Cap screw	M5x25
13	401101012	Hex Nut	M16
14	401140020	Washer	Ø16
15	401140010	Washer	Ø6
16	401150003	Lock Washer	Ø6
17	401022055	Cap screw	M6X20
18	401072086	Set screw	M12x55

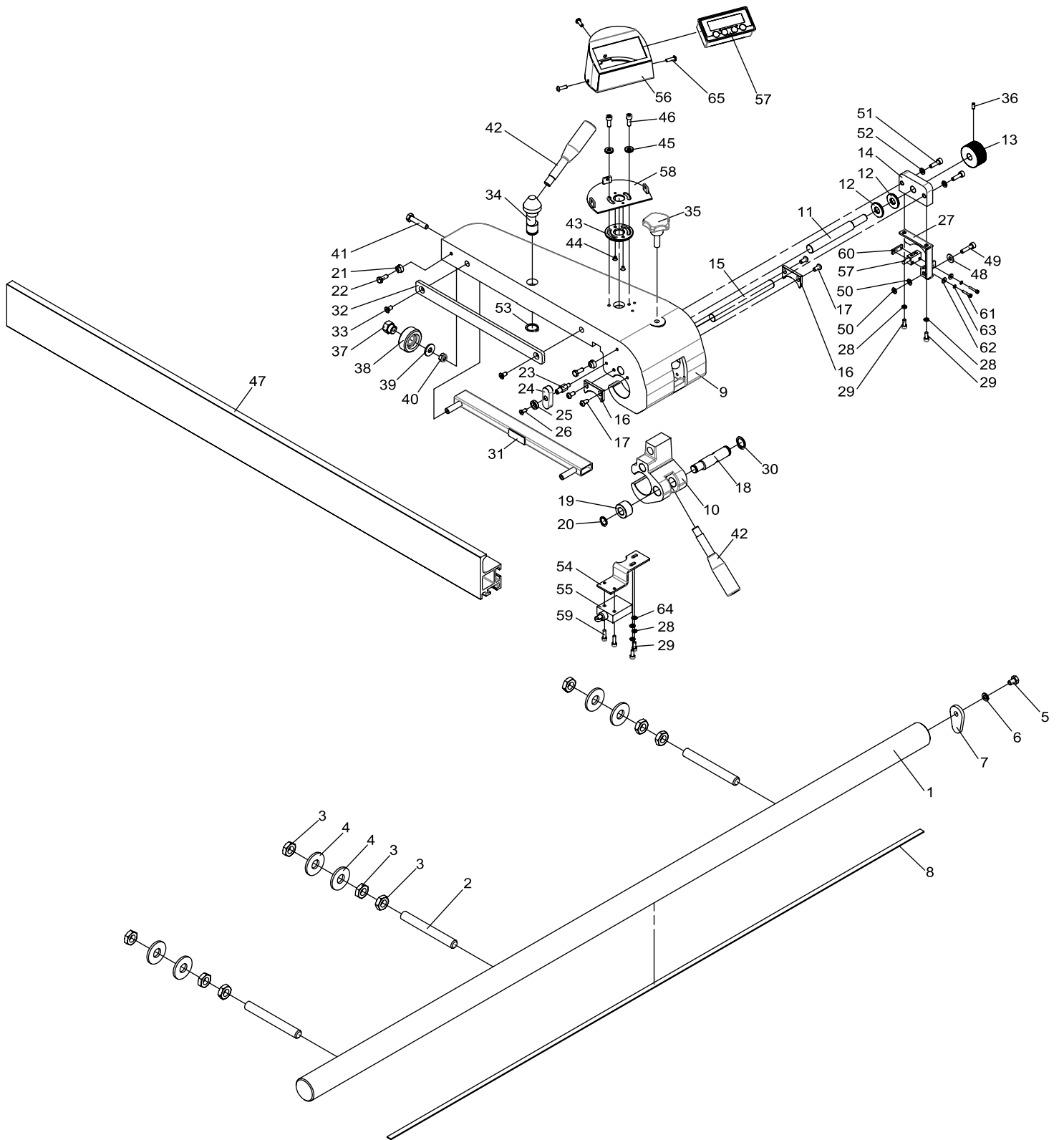

NO	FIG.NO.	DESCRIPTION	SPEC
1	LST-F002M	Slide rail	1.3M
2	401072135	Set screw	M16x130
3	401102001	Hexagon Thin Nut	M16x8t
4	401140007	Washer	Ø16
5	401011015	Hex Bolt	M8x12
6	401150003	Lock nut	Ø8
7	ST-Q077	Stop block	
8	415020005	Magnetic Ruler	1350mm
9	LST-F004	Fixed base	
10	LST-F005	Slide base	
11	ST-Q026	Adjust shaft	
12	ST-Q027	Washer	
13	402080003	Control knob	7021-42-B12
14	LST-F006	Fixed base	
15	LST-F007	Slide rail	
16	LST-F008	Dust scraper	
17	401032030	Button Head serew	M6x12
18	LST-F010	Fixed shaft	
19	ST-Q038	Lock ring	
20	401252009	Retaining rings for shaft	S14
21	ST-Q002	Guide wheel	
22	401010008	Hex head bolt	M6x16
23	ST-Q035	Hex head screw	
24	LST-F009	Guide key	
25	ST-Q033	Fixed Ring	
26	401052118	Counter sunk head cap screw	M5x12
27	LST-F018	Fixing frame	
28	401150002	Lock Washer	Ø5
29	401022028	Cap scre	M5x12
30	401252013	Retaining rings for shaft	S18
31	ST-Q010	Lashing bar	
32	ST-Q005	Lashing plate	
33	401052129	Counter sunk head cap screw	M6x12

NO	FIG.NO.	DESCRIPTION	SPEC
34	ST-Q011A	Fixed shaft	
35	402070006	Hand Knobs	HS50AM1030
36	401071025	Set serew	M5x10
37	ST-K044	Sliding wheel adjusting block	
38	ST-K043A	Sliding Wheel	
39	401140028	Washer	Ø8xØ23x3t
40	401103001	Anti-pine nuts	M8
41	401010023	Hex head bolt	M8x40
42	402010009	Handle	7107-M12-137
43	LST-F017	Washer	
44	401052108	Countersink Head Screw	M4x6
45	LST-F019	Washer	
46	401022053	Cap scre	M6x16
47	ST-Q014	Rip fence	
48	401140010	Lock Washer	Ø6xØ13x1t
49	401022056	Cap screw	M6x25
50	401102007	Hexagon Thin Nut	M6
51	401022055	Cap scre	M6x20
52	401150003	Lock Washer	Ø6
53	401252015	Retaining rings for shaft	S20
54	20255001-0	Fixed seat	
55	416040010	Micor switch	TZ-3112
56	20254002-0	Digital watch box	
57	415020024	Magnetic foot monitor	PT08 5cm
58	20254003-0	Connecting seat	
59	401020030	Cap screw	M5x16
60	ST-Q080	Fixed Base	
61	401022007	Cap Screw	M3x18
62	401140015	Washer	Ø3
63	401150010	Lock washer	Ø3
64	401140002	Washer	Ø5
65	401032020	Button Head serew	M5x16

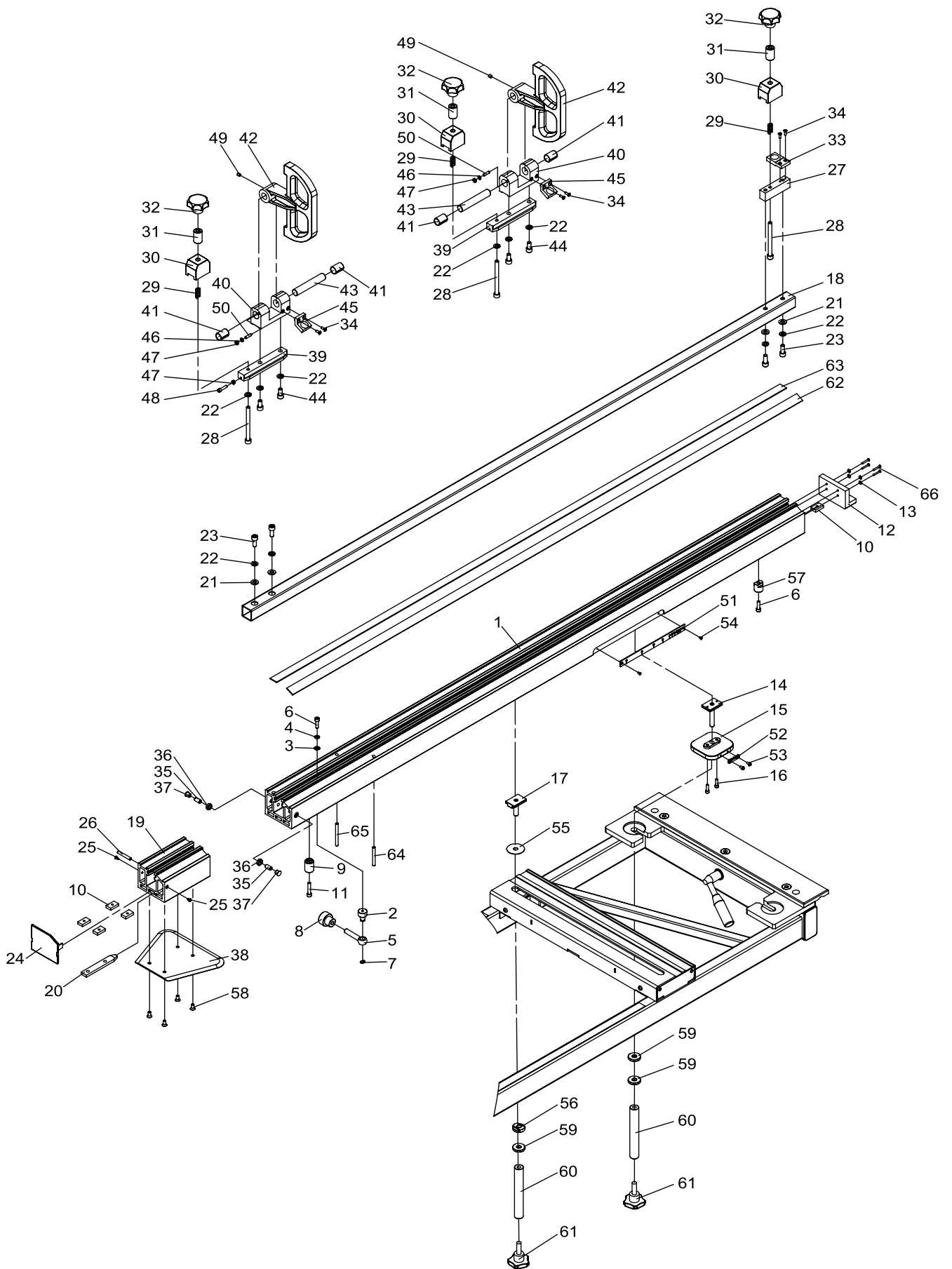

NO	FIG.NO.	DESCRIPTION	SPEC
1	ST-N058U-01	Fence scale base	
2	LST-G023	Fixed axis	
3	401140010	Washer	Ø6
4	401150003	Lock Washer	Ø6
5	402140001	Swing bolts	
6	401022055	Cap scre	M6x20
7	401252003	Retaining rings for shaft	STW-8
8	LST-G024	Emdossed nut	
9	LST-G022	Positioning column	
10	ST-N059	Fixing sheet	
11	401022057	Cap screw	M6x30
12	ST-N052	Lengthening scale base	
13	401140001	Washer	Ø4
14	20275005-0	T-slider	
15	20275006-0	Fixed block	
16	401020030	Cap screw	M5x16
17	20275004-0	T-slider	
18	ST-N006	Positioning pipe	
19	ST-N061	Scale Base	
20	ST-N055	Positioning pin	
21	401151002	Safety Washer	Ø8
22	401150004	Lock Washer	Ø8
23	401022078	Cap scre	M8x20
24	ST-N060	Left cover plate	
25	401060004	PLUG	1/8"-3/8"
26	401200008	Spring Pin6x40	Ø6x40
27	ST-N018	Locking lower slide block	
28	401021092	Cap screw	M8-90
29	ST-N022	Spring	
30	ST-N013	Locking slide block	
31	ST-N014	Locking bush	
32	402070002	Star-ahaped knob	HS50AM8
33	ST-N015	Magnifier	

NO	FIG.NO.	DESCRIPTION	SPEC
34	401051110	Counter sunk head cap screw	M4x12
35	ST-N107	Set screw	
36	401101005	Hex Head Bolt	M8
37	414080008	Hole plug	HP-9
38	ST-N054A	Butterly-shaped plate	
39	ST-N027	Locking lower slide base	
40	ST-N007	Adjusting block	
41	403090028	Bush	MB1625
42	ST-N008	Positioning plate	
43	ST-N011	Shaft	
44	401022076	Cap screw	M8-16
45	ST-N053	Magnifier	
46	401150002	Lock Washer	Ø5
47	401101003	Hex Nut	M5
48	401022032	Cap scre	M5x20
49	401072033	Setscrew	M6X6
50	LST-N091B	Set Screw	M5x16
51	20275007-0	Offset scale	
52	ST-M335A	Index	
53	401032008	Button head screw	M4x8
54	401053101	Countersink Hend Screw	M3x5
55	ST-N005	Washer	
56	20275003-0	Washer	
57	20275008-0	Positioning column	
58	401052129	Counter sunk head cap screw	M6x12
59	LST-G018A	Washer	
60	20275002-0	Locking handle	
61	402070006	Male hand knobs	HS50AM1030
62	ST-N434	Scale	
63	ST-N435	Scale	
64	401072046	Set serew	M6x50
65	401072144	Set serew	M6x60
66	401080011	Phillips sunk head cap scre	M3x20

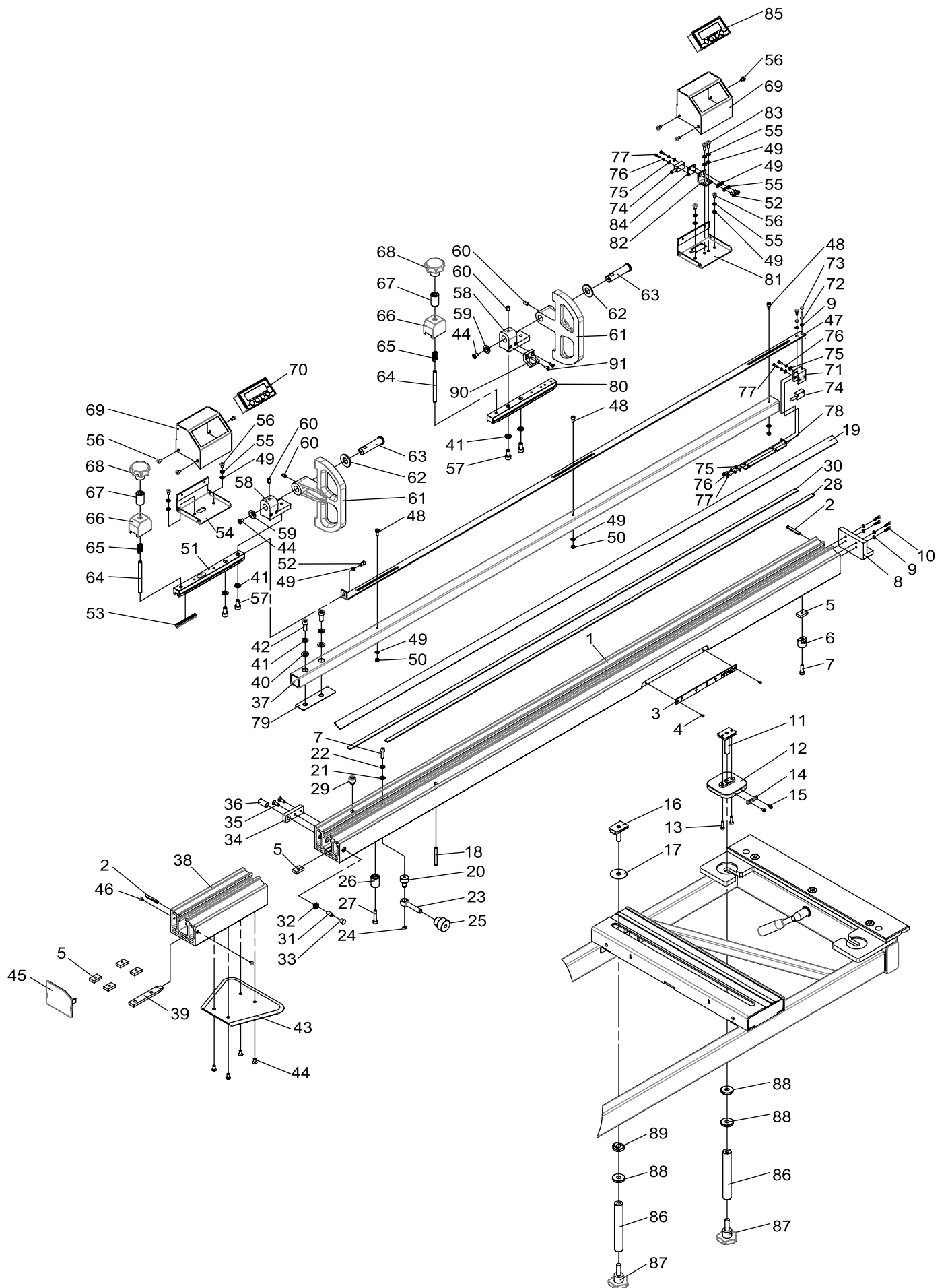

NO	FIG.NO.	DESCRIPTION	SPEC
1	ST-N058V-01	Fence Scale Base	
2	401200008	Spring Pin	Ø6x40
3	20275007-0	Offset scale	
4	401053101	Countersink Head Screw	M3x5
5	ST-N059	Fixing sheet	
6	20275008-0	Positioning column	
7	401022055	Cap screw	M6x20
8	ST-N052	Lengthening scale base	
9	401140001	Washer	Ø4
10	401080011	Phillips sunk head cap screw	M3x20
11	20275005-0	T-slider	
12	20275006-0	Fixed block	
13	401020030	Cap screw	M5x16
14	ST-M335A	Index	
15	401032008	Button head screw	M4x8
16	20275004-0	T-slider	
17	ST-N005	Washer	
18	401072046	Set screw	M6x50
19	ST-N028F	Scale	
20	LST-G023	Fixed axis	
21	401140010	Washer	Ø6
22	401150003	Lock Washer	Ø6
23	402140001	Swing bolts	
24	401252003	Retaining rings for shaft	STW-8
25	LST-G024	Embossed nut	
26	LST-G022	Positioning column	
27	401022057	Cap screw	M6x30
28	415020013	Magnetic ruler	1450mm
29	ST-N094	Stop screw	
30	415020014	Magnetic ruler	1520mm
31	ST-N107	Set screw	
32	401101005	Hex Head Bolt	M8
33	414080008	Hole plug	HP-9
34	ST-N438	Fixed block	
35	401052131	Counter sunk head cap screw	M6x16
36	401071080	Fixing screw	M12x25
37	ST-N006D	Position pipe	
38	ST-N058-02	Fence Scale Base	
39	ST-N055	Positioning pin	
40	401151002	Safety Washer	Ø8
41	401150003	Lock nut	Ø8
42	401022078	Cap screw	M8x20
43	ST-N054B	Butterfly-shaped plate	
44	401052129	Counter sunk head cap screw	M6x12
45	ST-N060	Left cover plate	
46	401060004	PLUG	1/8"-3/8"

NO	FIG.NO.	DESCRIPTION	SPEC
47	ST-N102	Link	
48	401022027	Cap screw	M5x10
49	401140002	Washer	Ø5
50	401101003	Hex screw	M5
51	ST-N066E	Lock slide base	
52	401022026	Cap screw	M5x8
53	408110003	Slot cover	
54	ST-N065D	Cover	
55	401150002	Lock Washer	Ø5
56	401042107	Phillips sunk head cap screw	M5x8
57	401022076	Cap screw	M8x16
58	ST-N073A	Fixed base	
59	ST-N101	Washer	
60	401072035	Set screw	M6x10
61	ST-N008	Positioning plate	
62	ST-N100	Washer	
63	ST-N099	Pivot axis	
64	401072138	Set screw	M8x90
65	ST-N022	Spring	
66	ST-N013	Locking slide block	
67	ST-N014	Locking bush	
68	402070002	Star-shaped knob	HS50AM8
69	ST-N064E	Cover	
70	415020025	Digital display	PT08 3m
71	ST-N103	Fixed block	
72	401150001	Lock washer	M4
73	401022013	Cap screw	M4x10
74	415020012	Digital display	
75	401140015	Washer	Ø3
76	401150010	Lock washer	Ø3
77	401022003	Cap screw	M3x10
78	ST-N112	Protective sheet	
79	ST-N113	Packing Up block	
80	ST-N066D	Lock slide base	
81	ST-N065C	Cover base	
82	ST-N067	Fixed Rack	
83	401022028	Cap screw	M5x12
84	ST-N068	Fixed board	
85	415020024	Digital display	PT08 5cm
86	20275002-0	Locking handle	
87	402070006	Male hand knobs	HS50AM1030
88	RH-2040	Washer	
89	20275003-0	Washer	
90	ST-N053	Magnifier	
91	401051110	Counter sunk head cap screw	M4x12

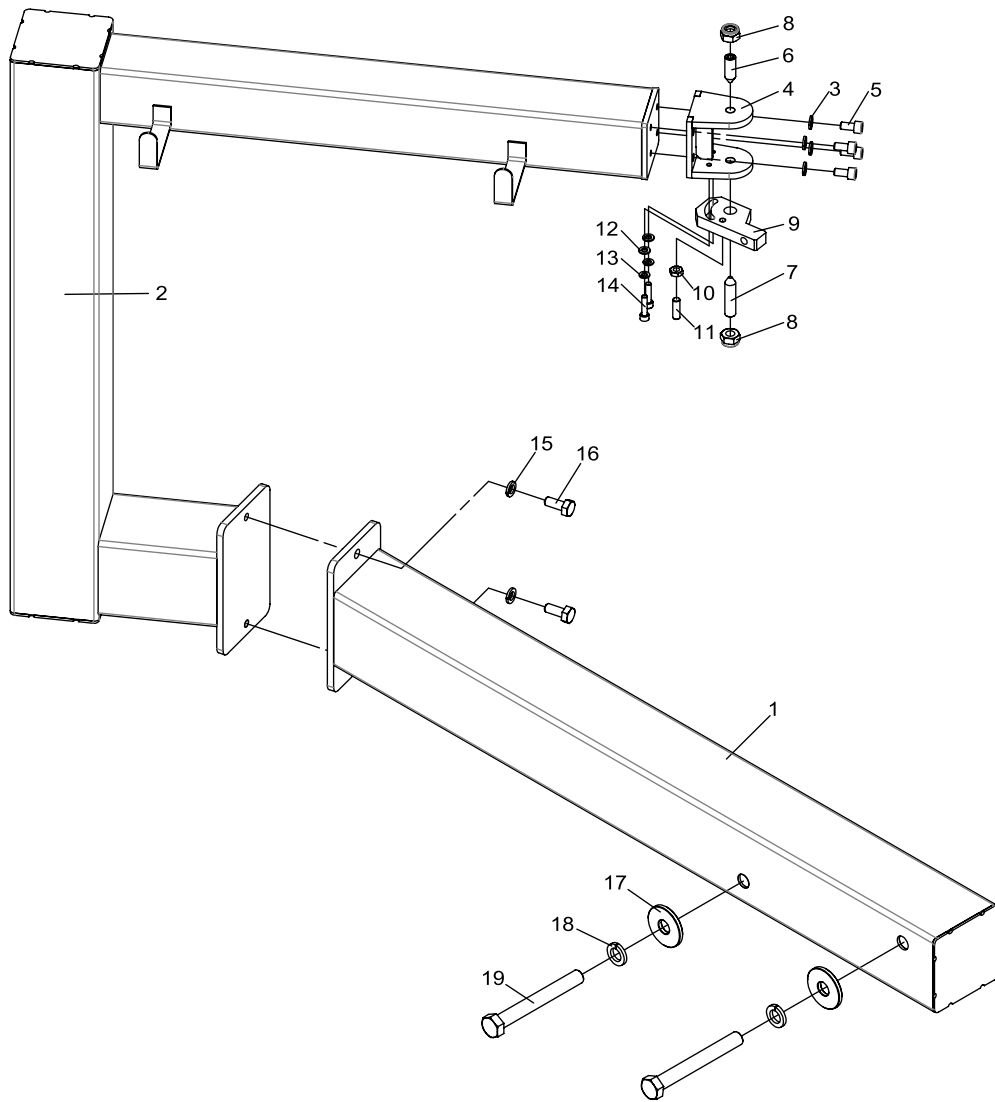

NO	FIG.NO.	DESCRIPTION	SPEC
1	LST-H004A	Lower Support Arm(350 · 400)	1.3m
2	LST-H005A	Upper Support Arm(350)	
3	401150003	Lock nut	Ø8
4	ST-D525-0-1	Fasten Base	
5	401022076	Cap screw	M8x16
6	ST-I023	Set Screw	
7	ST-D533-0-1	Set Screw	
8	401103003	Lock nut	M12
9	ST-D526-0-0	Adjust Block	
10	401101005	Hex Head Bolt	M8

NO	FIG.NO.	DESCRIPTION	SPEC
11	401072055	Set screw	M8x25
12	401140010	Washer	Ø6
13	401150003	Lock Washer	Ø6
14	401022056	Cap screw	M6x25
15	401150005	Lock washer	Ø10
16	401010037	Hexagon screw	M10x25
17	LST-H003	Washer	
18	401150008	Lock Washer	Ø8
19	401010075	Hex Head Bolt	M16x130

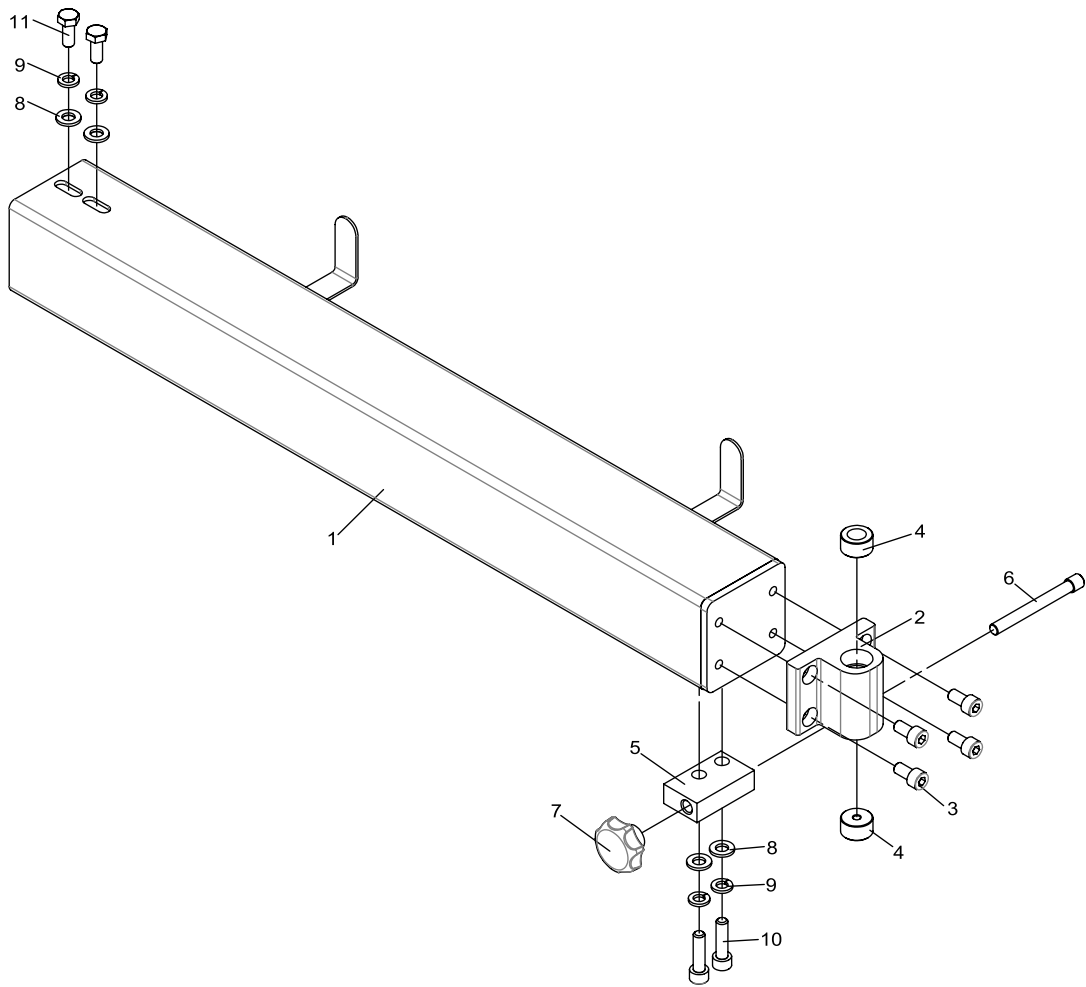

NO	FIG.NO.	DESCRIPTION	SPEC
1	ST405-609	Rotery Arm	1.3m
2	ST-D027B	Connect Block	
3	401022076	Cap screw	M8x16
4	ST-D527-0-0	Bush	
5	ST-D529-0-1	Fixed Base	
6	ST-D531-0-0	Lock Shaft	
7	402070002	Knob	HS50AM8
8	401140004	Washer	Ø8
9	401150003	Lock nut	Ø8
10	401022080	Cap screw	M8x30
11	401010019	Hex Head Bolt	M8x20

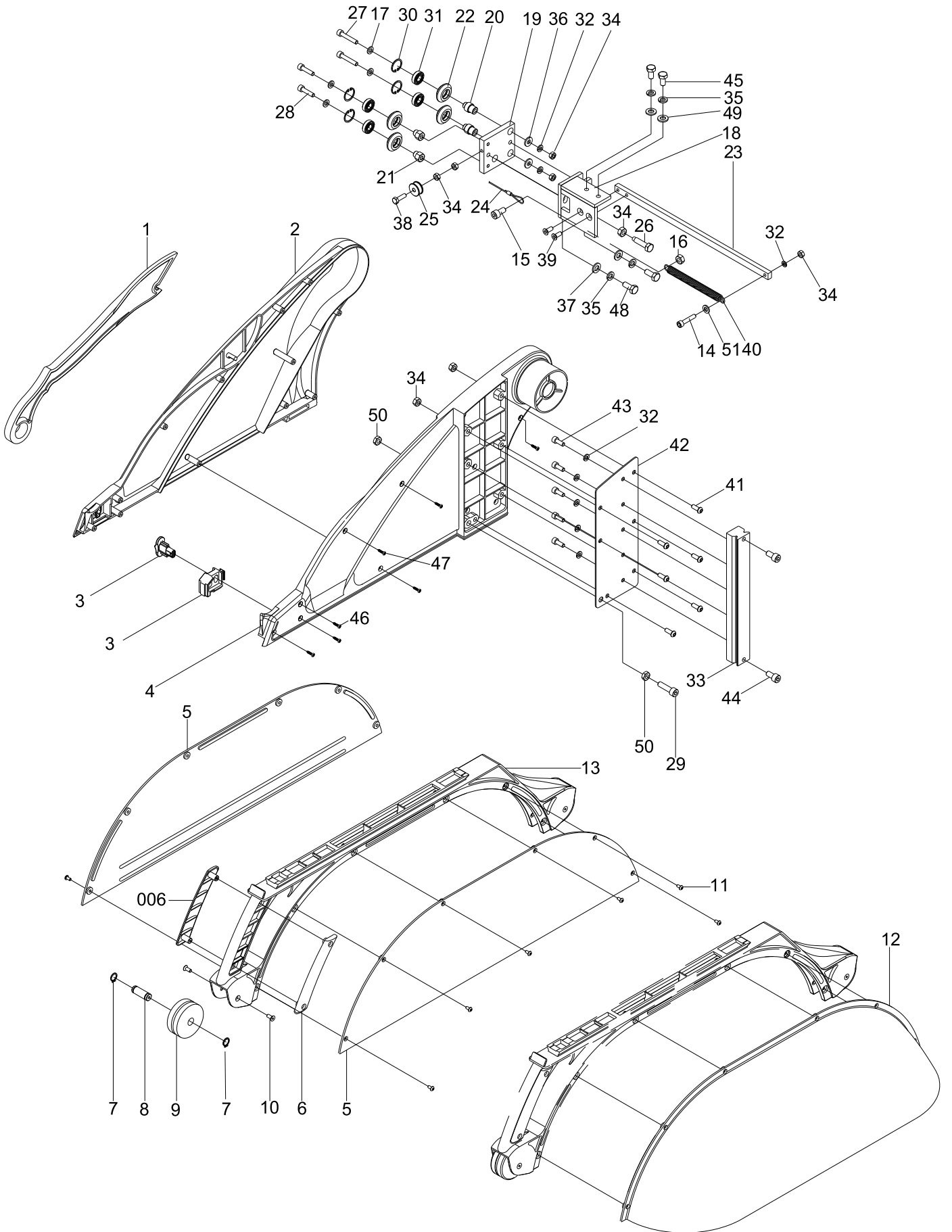

NO.	FIG. NO.	DESCRIPTION	SPEC
1	ST-Q047B	Push Stick	
2	ST-D311A	Left Safety Guard	
3	ST-D314	Open/Lock Button	
4	ST-D311B	Right Safety Guard	
5	ST-D303A	Chip Guard Cover	
6	ST-D313	Grip Cover	
7	401252007	Retain Ring	$\varnothing 12$
8	ST-D032A	Pin	
9	ST-D033A	Slide Wheel	
10	401052118	Countersink Head Screw	M5x12
11	401032008	Button Head Screw	M4x8
12	ST-D304A	Chip Guard Cover	
13	ST-D312	Grip Cover Base	
14	401022057	Cap Screw	M6x30
15	401022051	Cap Screw	M6x12
16	401103005	Lock Nut	M6
17	ST-D522-0-0	Washer	
18	ST-D512-0-1	Fixed Base	
19	ST-D513-0-1	Fixed Block	
20	ST-D514-0-1	Fixed Shaft	
21	ST-D515-0-1	Adjust Shaft	
22	ST-D516-0-1	Slide Wheel	
23	ST-D519-0-1	Spring Fixed Bar	
24	ST-D521-0-0	Wire Rope	
25	ST-D524-0-0	Slide Wheel	
26	ST-D520-0-1	Setscrwe	

NO.	FIG. NO.	DESCRIPTION	SPEC
27	401022058	Cap Screw	M6x35
28	401022056	Cap Screw	M6x25
29	401022082	Cap Screw	M8x40
30	401251017	Retain Ring	$\varnothing 22$
31	403013232	Ball Bearing	6900
32	401150003	Lock Washer	$\varnothing 6$
33	ST-D518-1-0	Slide Wheel	
34	401101004	Hex Nut	M6
35	401150004	Lock Washer	$\varnothing 8$
36	401140003	Washer	$\varnothing 6x \varnothing 16$
37	401140016	Washer	$\varnothing 8x \varnothing 23$
38	401032035	Button Head Screw	M6x30
39	401052129	Countersink Head Screw	M6x12
40	ST-D038A	Spring	
41	401032033	Button Head Screw	M6x20
42	ST-D315	Join Block	
43	401022015	Cap Screw	M6x12
44	401022076	Cap Screw	M8x16
45	401010019	Hex Head Bolt	M8x20
46	401060001	Phillips Head Screw	1/8"x3/4"L
47	401060003	Phillips Head Screw	1/8"x5/8"L
48	401010018	Hex Head Bolt	M8x16
49	401140016	Washer	$\varnothing 8x \varnothing 23x3t$
50	401103005	Hex Nut	M8
51	401140010	Washer	$\varnothing 6x \varnothing 13$

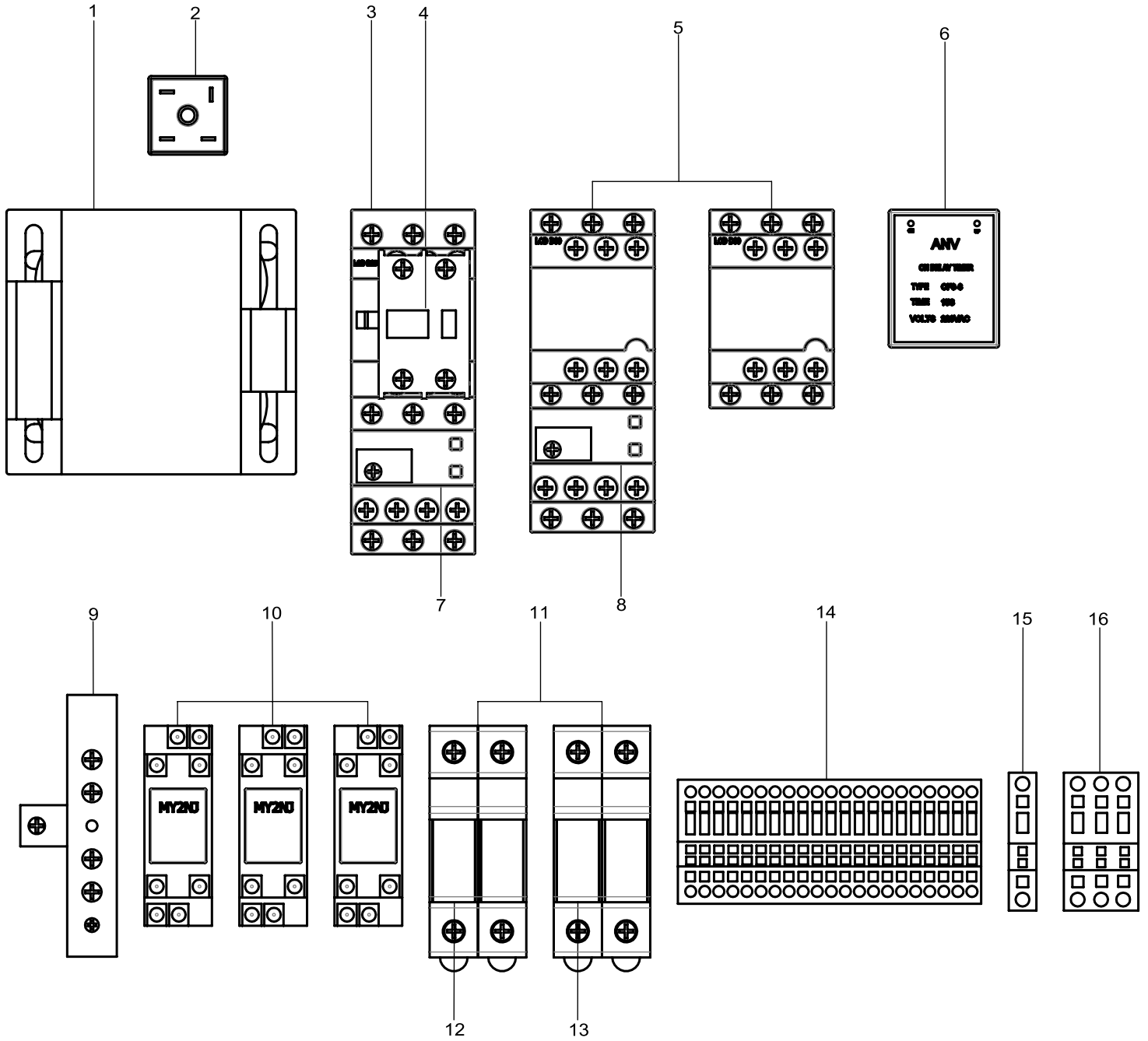

NO	FIG.NO.	DESCRIPTION	SPEC
1	416071037	transformer	160VA
2	416081001	Bridge Rectifier	KBPC 2506
3	416021128	Electromagnetic contactor	LC1-D25(M7)
4	416240001	Auxiliary contact	LADN11
5	416021109	Electromagnetic contactor	LC1-D09(M7)
6	416091008	Timer	CF3-3 6S(220V)
7	416220003	Thermal Relay	LR3-D22
8	416220001	Thermal Relay	LR3-D08

NO	FIG.NO.	DESCRIPTION	SPEC
9	416230001	Ground plate	5P
10	416023001	Relay	MY-2NJ AC220V
11	416051014	Fuse Holder	DF102 10x38 2P
12	416052025	Input fuses	4A GG
13	416052012	Input fuses	2A GG
14	414041017	Terminal Block	PT-2.5
15	414041019	Terminal Block	PT-6PE
16	414041018	Terminal Block	PT-6

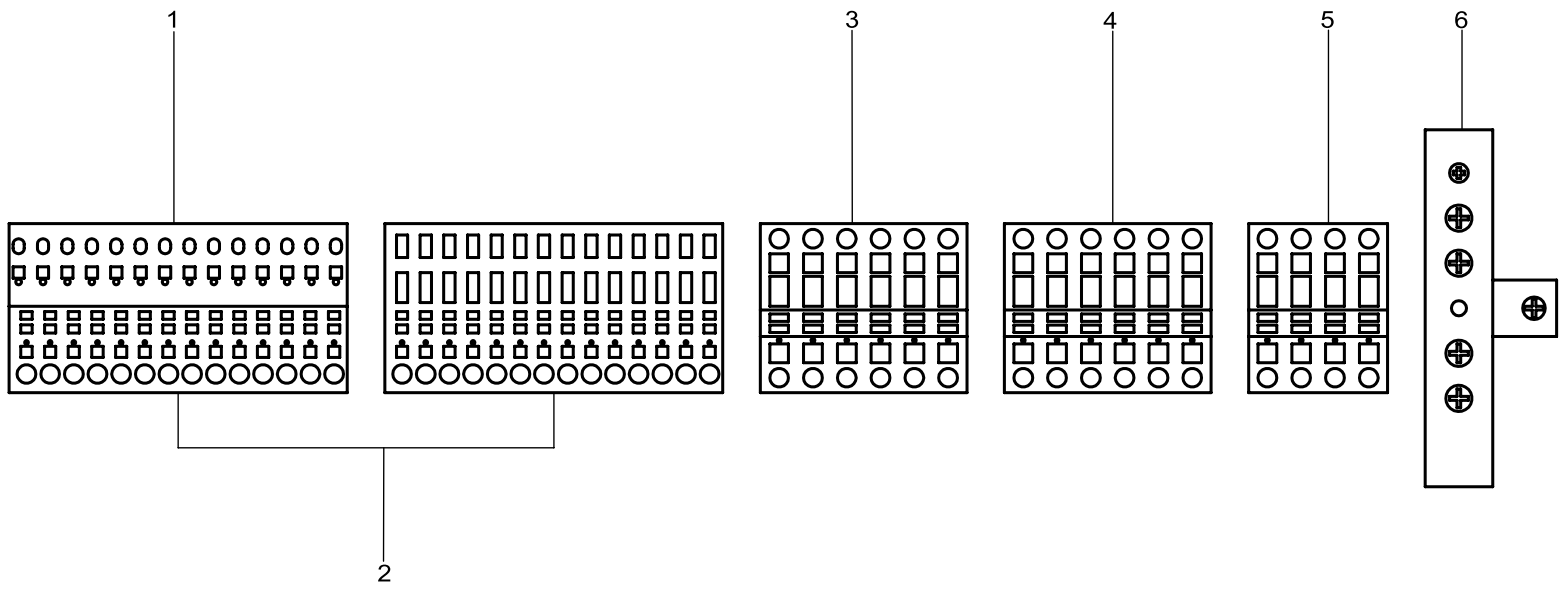

NO	FIG.NO.	DESCRIPTION	SPEC
1	414041022	Terminal Block(Active end)	PP-H4/14
2	414041021	Terminal Block	PT4/1P
3	414041018	Terminal Block	PT-6
4	414041020	Terminal Block	PT-4
5	414041017	Terminal Block	PT-2.5
6	416230001	Ground plate	5P