

Ironwood FX 550

User Manual

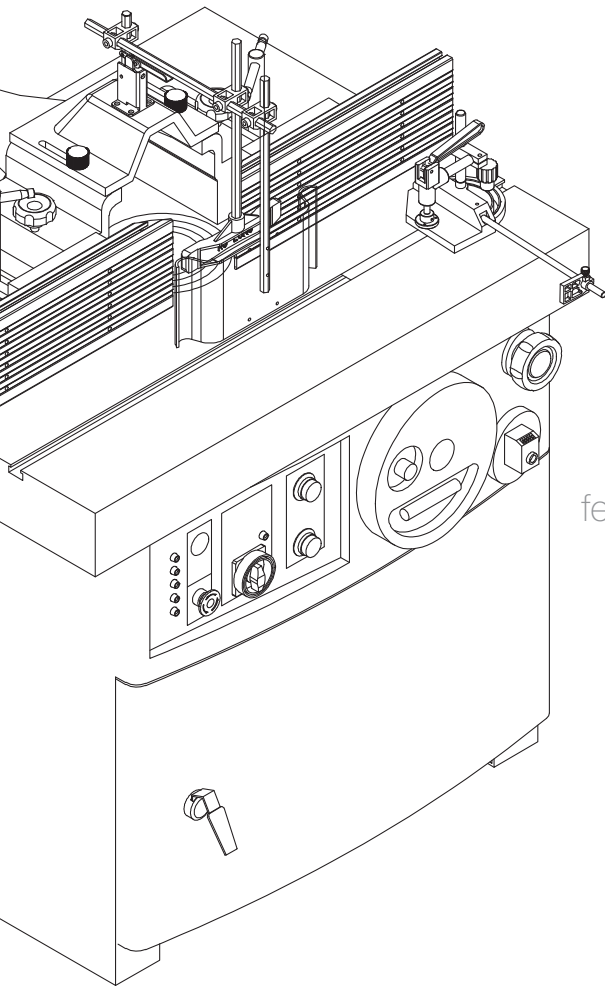

general information. features,
technical specifications, safety considerations,
delivery and installation. inspection,
receiving the machine, **assembly.**
fences and fence assembly, safety guard assembly,
operation. spindle height adjustment,
tool adjustments, noise reduction,
maintenance. troubleshooting,
periodic maintenance, **safety.**

IRONWOOD

stiles

Table of Contents

1.0	General Information	3
1.1	Thank You!	
1.2	Before Contacting Stiles	
1.3	Features	
1.4	Intended Use	
1.5	Technical Specifications	
1.6	Safety Considerations	
2.0	Facility Preparation	6
2.1	Floor	
2.2	Work Space	
2.3	Power	
3.0	Delivery and Installation	7
3.1	Receiving Your Machine	
3.2	Unpack the Machine	
3.3	Inspection	
3.4	Move Machine to Final Position	
3.5	Remove Machine from Pallet	
3.6	Level	
3.7	Pre-Operation Cleaning	
4.0	Assembly	10
4.1	Fence Assembly and Fences	
4.2	Spindle	
4.3	Cutter Head/Tooling	
4.4	Top Dust Cover	
4.5	Safety Guard Assembly	
4.6	Miter Gauge Assembly and Clamp	
5.0	Connect to Power	14
6.0	Safety.	15
7.0	Start the Machine.	16
7.1	Control Panel	
7.2	On/Off	
7.3	Reverse Spindle Rotation	
8.0	Operation.	17
8.1	Speed Change and Belt Adjustment	
8.2	Spindle Height Adjustment	
8.3	Using Fence(s)	
8.4	Adjusting Fence Extensions	
8.5	Positioning and Using Collars	
8.6	Tenoning	
8.7	Tool Adjustments	
8.8	Noise Reduction	
9.0	Maintenance.	21
9.1	Lubrication	
9.2	Inspection	
9.3	Periodic Maintenance	
10.0	Troubleshooting	22
10.1	Electrical Diagram	

 **PLEASE REVIEW AND OBSERVE ALL SAFETY INFORMATION / DIRECTIVES BEFORE INSTALLING, OPERATING, OR PERFORMING MAINTENANCE ON THIS MACHINERY.**

1.0 General Information

1.1 Thank You!

Thank you for your purchase of the Ironwood FX 550 Shaper. At Stiles Machinery, our goal is to ensure that you are fully satisfied with your purchase. This manual is provided so that you may properly assemble, operate, and maintain your FX 550. Should you need help, our team of dedicated service personnel are available to answer your questions and provide any resource recommendations you may need.

Warranty and Support

All Ironwood machines are designed to meet the exacting standards demanded by craftsmen like you. Ironwood machines include a one (1) year parts warranty and two (2) years of free 24/7 technical support beginning at date of shipment. Standard technical support remains in effect for free for the lifetime of the machine thereafter. Warranty service work is not covered by manufacturer's warranty. Stiles' service team is available for an additional charge.

1.2 Before Contacting Stiles

Please have your machine model and serial number available when contacting Stiles Machinery with questions. The machine's model and serial number are listed on the metallic plate located on the machine's frame.

Information regarding the electrical system is also listed on the metallic plate.

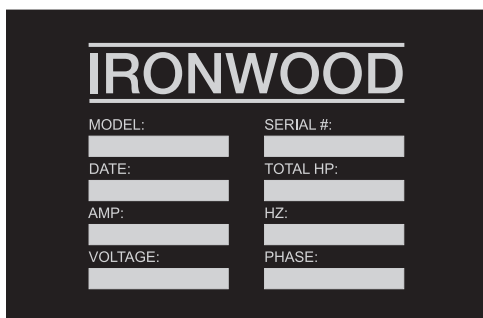

Stiles Technical Support
616.698.6615

Stiles Parts
800.PARTS.80 (800.727.8780)

Website
www.stilesmachinery.com/ironwood/fx550

Machine Model _____

Machine Serial Number _____

1.3 Features

- Cast iron, ground and polished table is designed for heavy cutting operations.
- Generous table size supports large workpieces
- 1¼" interchangeable spindle has over 6 ¼" (160mm) of spindle capacity under the nut. Other spindle diameters are also available. Contact Stiles Machinery for more information.
- Cast iron fence assembly provides independent fine adjustments for infeed and outfeed fence positioning.
- Directional indicator light for forward and reverse spindle rotation control ensure safe operation in clockwise and counterclockwise applications.
- Digital readouts for spindle height position and infeed and outfeed fence positions ensure precision.
- All control functions are located on the convenient and easy-to-use control panel.
- Electric mechanical spindle brake and spindle lock with safety limit switches enhance safety.
- Adjustable aluminum fingers on the fence protect the operator from the cutter and add support for the workpiece.

1.4 Intended Use

The Ironwood FX 550 shaper is designed for shaping and tenoning wood and wood material. Use your FX 550 to create outside profiles on workpieces such as raised panel doors, furniture components, trim, and custom moldings.

Performance and dependability are optimized when the machine is operated with care and maintained properly. When used according to the instructions in this manual, you can expect years of trouble-free operation.

The FX 550 shaper features a vertical spindle that protrudes from the table. The spindle turns at between 3,000-10,000 rpm. A cutter is mounted on the spindle. The workpiece is guided along the fence, passing over the cutter. The position of the cutter and the fence can be finely adjusted, allowing you to create a wide array of casings, moldings, trim, and more.

An optional sliding table or extension table should be used to support longer workpieces.

Power feeders are recommended to ensure consistent finish quality and improve operator safety.

All Ironwood shapers feature heavy-duty motors up to 10 hp and spindles driven by 5- or 6-speed balanced v-belt pulley systems for speeds ranging from 3,000 to 10,000 rpm (see section 4.2).

Ajustable Knobs both sides for infeed and outfeed fence positions help ensure precision

Large, cast iron, ground and polished table is rugged and stable, with maximum rigidity for heavy cutting operations

Generous table size provides support for larger workpieces

Adjustable fingers on the fence protect the operator from the cutter and add support for the workpiece.

Aluminum fence assembly provides independent fine adjustments for infeed and outfeed fence positioning

1 1/4" interchangeable spindle has over 6" of spindle capacity under the nut; other tooling diameters are also available

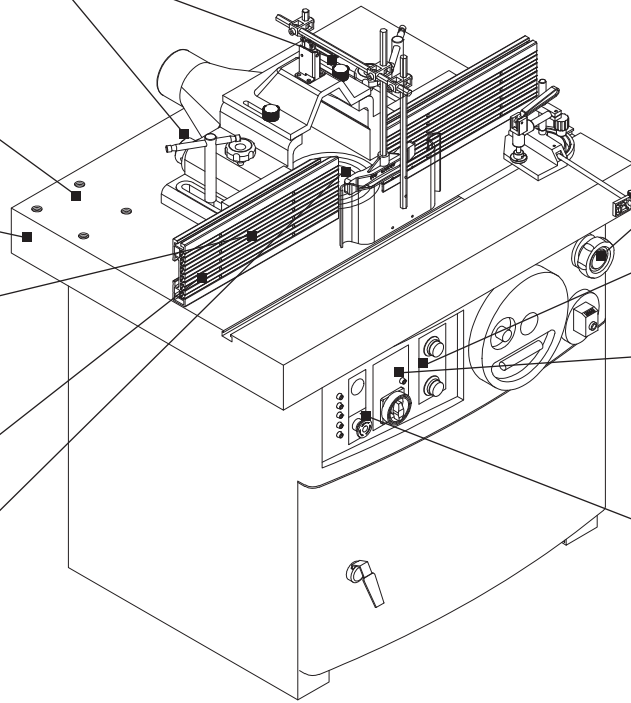

Spindle locks with safety limit switches enhance safety

Convenient and easy-to-use control panel handles all control functions

Directional indicator light for forward and reverse spindle rotation control ensures safe operation in clockwise and counterclockwise applications

Emergency stop for stopping motor with the spindle brake in 10 seconds

1.5 Technical Specifications

Description	Ironwood FX 550
Working Table	27-9/16" x 35-7/16" (700x900mm)
Table Height	35-7/16" (900mm)
Spindle Capacity (under the nut)	6" (152mm)
Vertical Spindle Stroke	7-1/16" (180mm)
Spindle Speed	5 Speeds (3000, 4000, 6000, 8000, 10000 RPM)
Spindle Height Adjustment	Handwheel
Spindle Position Display	Mechanical Digital Readout
Spindle Size	1-1/4" x 6" (31.75mm x 152.5mm)
Spindle Rotation	Forward/Reverse
Max. Tool Diameter (Below Table)	7-1/16" (180mm)
Max. Tool Diameter (Above Table)	8-7/8" (225mm)
Fence Assembly	Manual
Dust Port Diameter	2 @ 4"
Dust Extraction Requirements	1000 cfm @ 4,500 feet/min.
Motor	5.5 HP
Motor Power	230v (3 phase), 460v (3 phase)
Amperage	14.0 (230v) / 7.0 (460v)
Machine Weight	924 lbs. (420 kg.)
Shipping Dimensions (L x W x H)	42-15/16" x 34" x 42-1/8" (1090mm x 864mm x 1070mm)

1.6 Safety Considerations

For your safety, read these instructions thoroughly before you install and operate this machine. Always have these instructions available at the machine for reference.

Observe all codes and regulations that apply to the installation and operation of this machine.

Keep visitors at a safe distance from the workspace.

Keep children away from this and all machines. Childproof your work area!

Familiarize yourself with the safety notices used in this manual.

CAUTION

If cautions are ignored, personal injury and/or machine damage may result.

WARNING

If warnings are ignored, serious injury or death may result.

Warning Labels

This machine has warning labels attached to ensure safe operation. These warning labels are very important and should be kept clean and never be removed. If warning labels become damaged or lost, contact Stiles Machinery immediately for replacements.

Label 1 Safety rules and features

Label 2 Do not touch turning spindle or cutters

Label 3 Always wear eye and ear protection

Label 4 Optimum speed range

Label 5 Hazardous voltage

Label 6 Belt placement/speed diagram (inside access door)

Label 7 Spindle lock

Label 8 CE marking regulations

WARNING

Never use the FX 550 for purposes other than its intended use. Do not modify or remove any guards or other safety features. Improper use or modifications may affect your warranty or result in serious injury or death.







Training

This machine is intended for use by authorized, well-trained operators only.

Do not operate this machine until you have a complete working knowledge of this shaper and have been properly trained for its safe operation, correct adjustment and use. All operators should thoroughly read and understand this manual and the workings of this machine prior to operation.

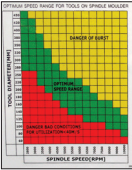
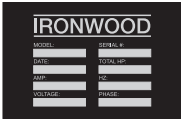
It is essential that all operators be aware of the following:

- The dangers associated with the operation of this machine.
- The use of personal protective equipment for ear and eye protection.
- The proper positioning of the operator and operator hands relative to the cutters.
- The principles of machine operation, proper use and adjustment of the fence, jigs, safety guards templates, extension tables and end stops.
- The correct selection of tools and the associated spindle speeds for each operation.
- The safe handling of the workpiece when cutting.
- The safe stacking of the workpiece before and after cutting.
- Connection of the optional power feed unit.

<p>MAIN MOTOR CAN START AND OPERATE THIS MACHINE ONLY IF THE DOOR IS COMPLETELY CLOSED AND SECURED.</p>		 	
LABEL NO. 1	LABEL NO. 2	LABEL NO. 3	LABEL NO. 4
		<p>*** WARNING ***</p>  <p>MAKE SURE SPINDLE LOCK KNOB IS INTO THE LOCKED POSITION (THREAD TO BOTTOM BEFORE TURNING ON THE MACHINE.</p>	
LABEL NO. 5	LABEL NO. 6	LABEL NO. 7	LABEL NO. 8

2.0 Facility Preparation

Prior to uncrating your machine confirm that your location can accommodate the Ironwood FX 550. Follow these guidelines:

2.1 Floor

- The floor must be flat and level.
- Although no special foundations are required, a concrete floor is recommended.
- All floors must have a load-bearing strength suitable for the machine weight of approximately 814 lbs.
- If anchoring the machine to the floor, purchase high quality anchor bolts appropriate to the floor construction and material.

2.2 Work Space

- Provide adequate work space surrounding the machine.
- Provide proper non-glare, overhead lighting.
- Place the machine so that any potential kickback area is not in line with aisles, doorways, or other work and traffic areas.
- Provide adequate dust extraction system. The dust extraction system should have a flow rate of 4,500 feet/min. at 1,000 cfm.
- Avoid exposure to any environment where vibration is present.

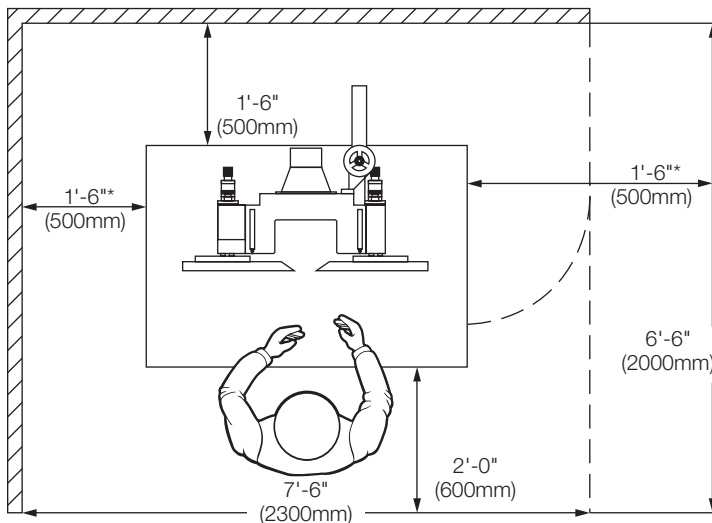

Standard machine clearance requirements*

*Actual clearance requirements may vary depending on length of material to be processed.

2.3 Power

⚠ WARNING

A licensed electrician must connect the FX 550 to the building power source.

- Do not use extension cords.
- Be sure that the electrical current of the power source is of the same characteristics as the electrical system supplied with your machine. If other machine voltage capabilities are required, contact Stiles Machinery.

	FX 550
Motor	5.5 HP
Motor Power	230v / 460v (3 phase)
Amperage	15.6 (230v) / 7.6 (460v)

- Ensure the machine is protected with an external over-current protective device per your local electrical codes.
- Electrical equipment operating conditions:
 - Air temperatures between +41°F (+5°C) and +113°F (+45°C).
 - Relative humidity not to exceed 50% at a maximum temperature of +113°F (+45°C).
- Electrical equipment is designed and protected to withstand the effects of transportation and storage temperatures within a range of -13°F (-25°C) to +131°F (+55°C), and for short periods of time not exceeding 24 hours at up to +158°F (+70°C).
- Ensure connection to factory ground system is wired correctly (IAW local electrical codes and NEC) and not connected to any electro magnetic interference source such as welders.

3.0 Delivery and Installation

3.1 Receiving Your Machine

You will be contacted to arrange delivery. Your machine will be delivered by truck to your location. If there is no loading dock, be sure that you have informed the carrier in advance so that they deliver using a truck with a lift gate to lower the machine to ground level.

Before accepting the machine and signing the bill of lading from carrier, please inspect crating and machine condition, note potential damage on the bill of lading, take pictures of potential damage, and contact Stiles Machinery immediately.

The machine will arrive fully crated and secured to a pallet. Use a hand truck or fork lift to move the machine on its pallet as close to its final position as possible.

If you do not intend to install the Ironwood Shaper immediately after delivery, store it in a protected, cool, and dry location.

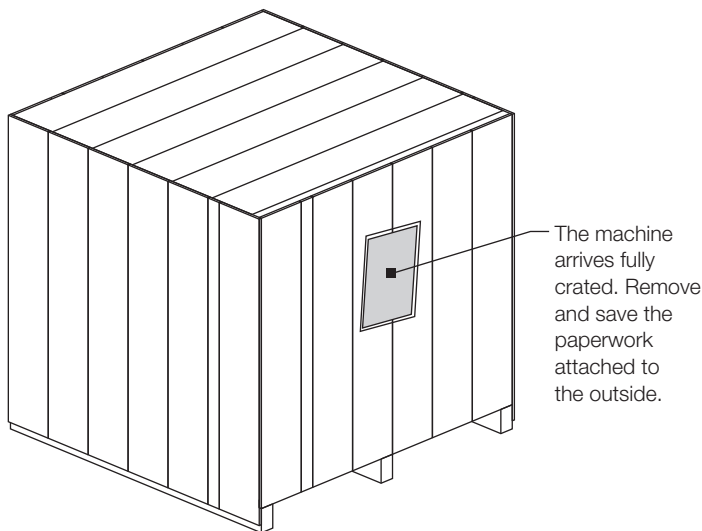
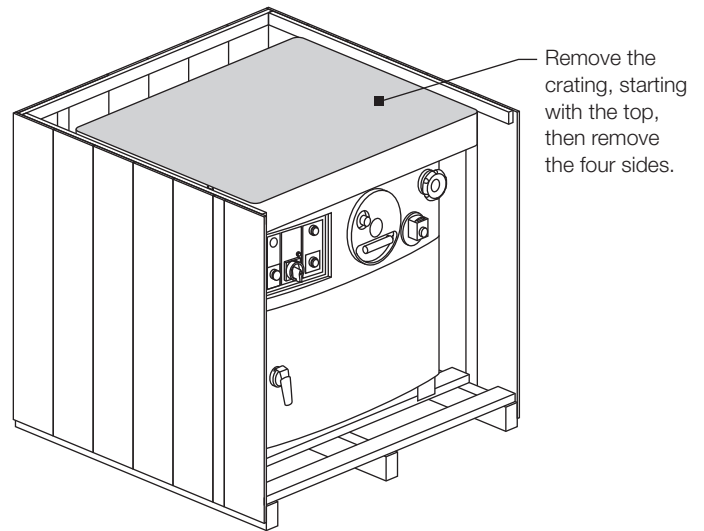

Do not remove the protective paper that covers the tabletop surface.

4. Remove the plastic sleeve from the front access door handle. The door is locked when the handle is in the vertical position. Turn the handle to the right to unlock and open the access door.
5. Remove the hardware, accessories, and a tool kit that are shipped inside the machine. If additional accessories are ordered, such as a power feeder, they are delivered on a separately.
6. Close and lock the front access door.

3.2 Unpack the Machine

TOOLS REQUIRED:

- Hammer
- Crowbar

Unpack as follows:

Do not remove the machine from the pallet.

1. Remove and save all paperwork attached to the outside of the crate.
2. Remove the crating, starting with the top, then remove the four sides. Use caution to avoid personal injury and prevent damage to the machine's finish.
3. Remove the protective plastic from the machine, starting at the bottom.

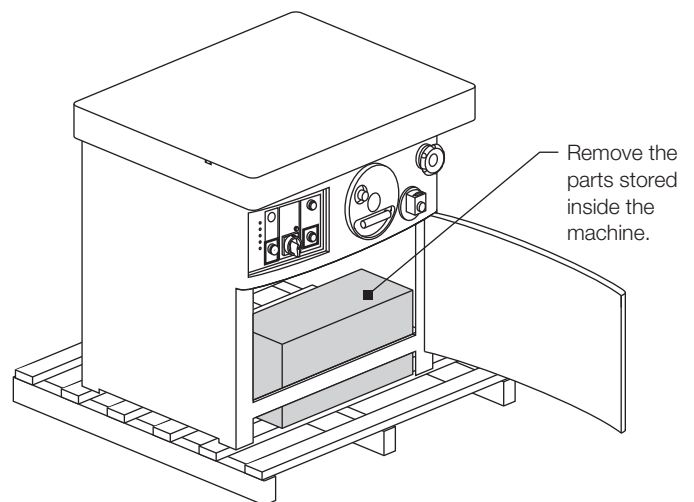

3.3 Inspection

Save all containers and packing materials until you are satisfied that your machine has arrived in good condition. If you discover the machine is damaged after you've signed for delivery, immediately call Stiles Customer Service.

When you are completely satisfied with the condition of your equipment, you should inventory its parts.

Open and check the contents of all containers to ensure all tools, hardware, and accessories are included. The tool kit should contain the following items:

1. 6-piece open end wrench set
2. T-wrench for fence with adjustable supporting bar
3. Spanner wrench for spindle retaining nut
4. 1¼" spindle nut wrench
5. 1¼" x 6" (152mm) spindle set with safety nut
6. 7-piece Allen wrench set
7. Grease gun
8. Cabinet handle key for locking/unlocking cabinet access door
9. Handwheel
10. Paint (2-color set)

3.4 Move Machine to Final Position

Be sure the site is properly prepared. Refer to section 2.0 for details.

Be sure the front access door is closed and locked before transporting.

TOOLS REQUIRED:

- Hand truck or fork lift

Use a hand truck or fork-lift to move the machine on its pallet to its final location. If using a fork lift, make sure fork travel is clear of any obstacles.

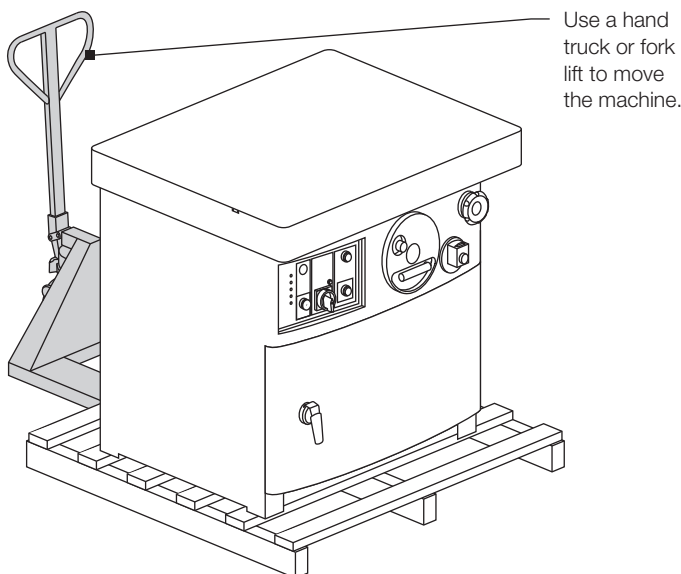

3.5 Remove Machine from Pallet

CAUTION

The FX 550 weighs 814 lbs. For this procedure, we recommend using four people.

TOOLS REQUIRED:

- Adjustable wrench
- Access door key

Carefully remove the machine from the pallet.

1. Remove the two bolts that secure the fence assembly.
2. Remove the fence assembly.
3. From inside the cabinet, remove the four 1/2" (13mm) bolts that secure the machine to the pallet at the interior corners.
4. Lift the machine from the pallet by one of 2 methods:
 - a. Team lift
 - b. Slide machine onto forks of fork lift
5. Carefully slide the machine into final position.

3.6 Level

TOOLS REQUIRED:

- Bubble Level
- Adjustable wrench

Use a bubble level along the length and width of the tabletop surface to check for level. Use an adjustable wrench to adjust leveling bolts to level machine.

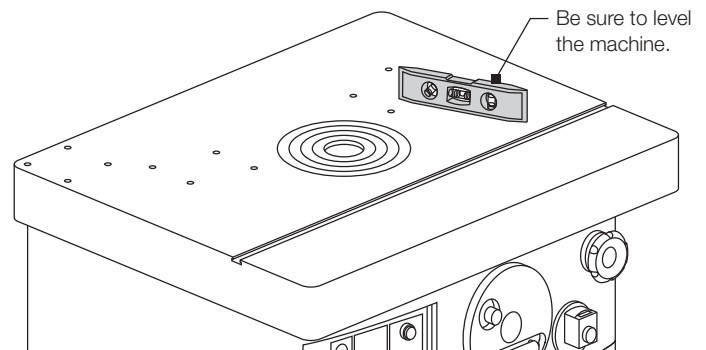

3.7 Pre-Operation Cleaning

⚠ WARNING

Use proper cleaning agents and methods described below. Do not use gasoline or other petroleum-based solvents. Risk of fire or explosion.

Machine Tabletop Surface

Remove and discard the protective paper from the top of the machine. Use a soft cloth and nonflammable degreasing agent, such as Simple Green or other citrus-based cleaners to carefully clean off all grease. Do not use abrasive pads.

Table Rings

Spindles are fitted with up to three table rings for a wide variety of tooling configurations. Table rings may be inserted or removed individually. Remove and clean the rings, starting with the innermost ring.

Be aware that the rings fit tightly. To remove a ring, place fingers inside ring and position on opposite sides. Gently rock the ring back and forth to release the pin. Remove all rings and clean with degreasing agent.

⚠ CAUTION

Threads on the spindle and spindle shaft are very sharp. Use care when cleaning to prevent injury.

With all rings removed, thoroughly clean the taper of the spindle and the internal taper of the spindle shaft.

To replace the rings, start with the outer ring. Align the locator pin on the bottom of the ring with the insert on the outer rim. Repeat for each ring.

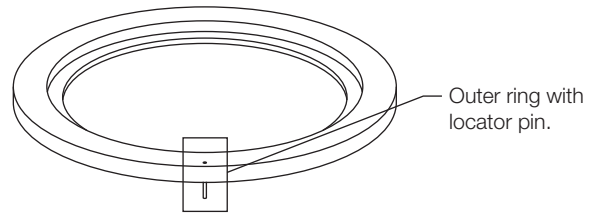
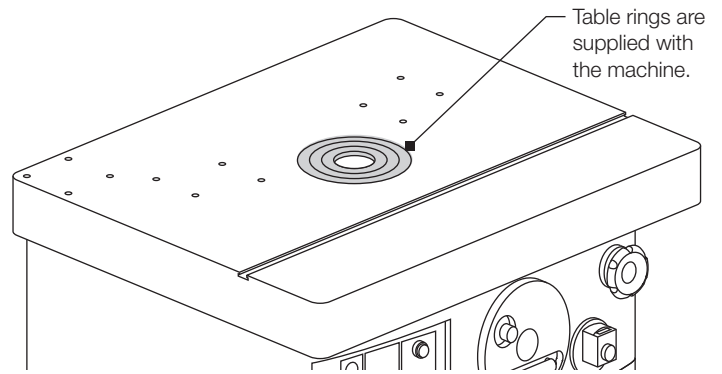

4.0 Assembly

To be assembled:

- Fence Assembly and Fences
- Spindle
- Cutter Head/Tooling
- Top Dust Cover
- Safety Guard Assembly
- Mitre Gauge Assembly and Clamp

4.1 Fence Assembly and Fences

⚠ CAUTION

For this procedure, we recommend using two people.

PARTS REQUIRED:

- Fence assembly

TOOLS REQUIRED:

- Allen wrench set
- Adjustable wrench

The fence should always be used for straight work cutting to guide the workpiece.

The fence has two halves: An infeed fence and an outfeed fence. Both must be installed to the fence assembly. The infeed fence is on the right as you face the machine; the outfeed fence is on the left.

The cast iron fence assembly is adjustable, and the slotted aluminum fences can be adjusted to maximize safety and allow precision shaping for every cutter used on the machine. Independent fine adjustments and digital readouts are included to precisely position infeed and outfeed fences. Quick fence changeovers provide the flexibility needed to create quality profiles in a short time.

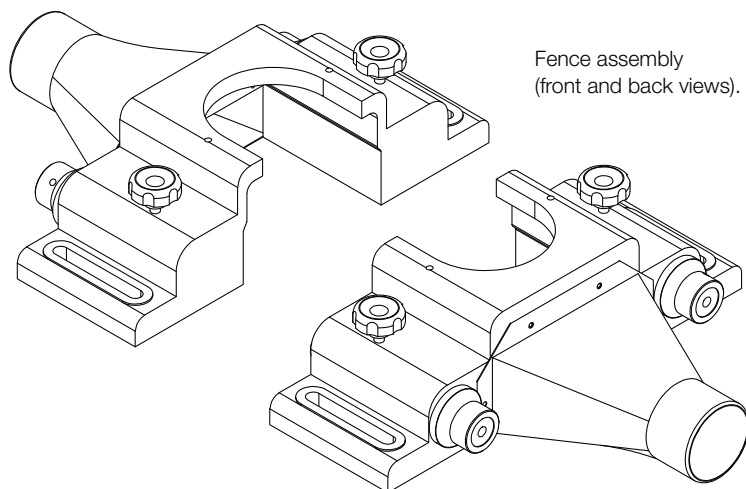

1. Locate the bracket at the rear of the table. Remove the screws from the horizontal arm of the bracket and set them aside.
2. Place the fence assembly body on the rear of the table as shown, aligning the forward set of pilot holes with the bracket holes.
3. Reattach the screws to secure the fence to the bracket. Do not fully tighten.
4. Fasten locking bars to the front of each fence block half using the locking lever and washer. Locking levers are spring-loaded and can be repositioned by pulling out the handle or by using an Allen wrench.
5. With the locking levers loosened, slide the infeed fence half and outfeed fence halves onto the locking bars. Be sure the beveled end of each fence faces the center of the table. Tighten each fence using its locking lever and washer.

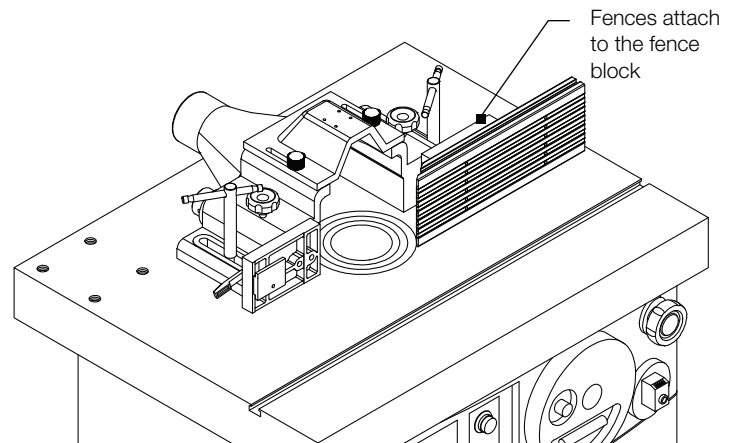

6. Locate the two fence locking handles and washers. Attach the handles in the slots. Position the fence so that the locking handles align with the forward two sets of holes located on the machine table. Tighten the locking handles.
7. To reposition the complete fence assembly on the table, loosen the two locking handles, move the fence assembly to the desired position, and tighten the two locking handles.

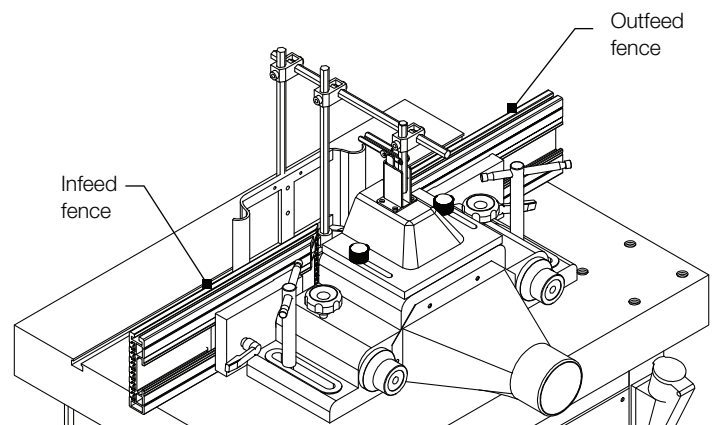

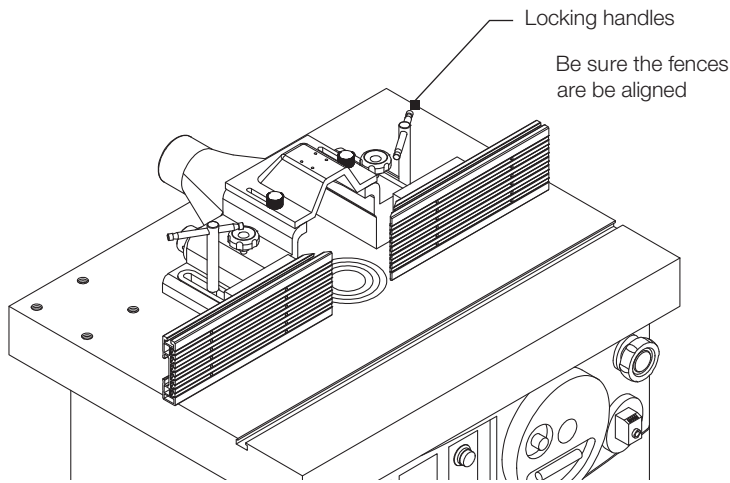

- Adjustment of the fences depends upon the configuration of your machine. If adjusting screws are present on your model, adjusting screws will be used for alignment. To adjust fences for parallelism, either adjust adjustment screws or place shims between the round rods and fence block until both fences are parallel to one another. Fences are aligned at the factory but may move during shipping. Check parallelism before continuing with procedure.

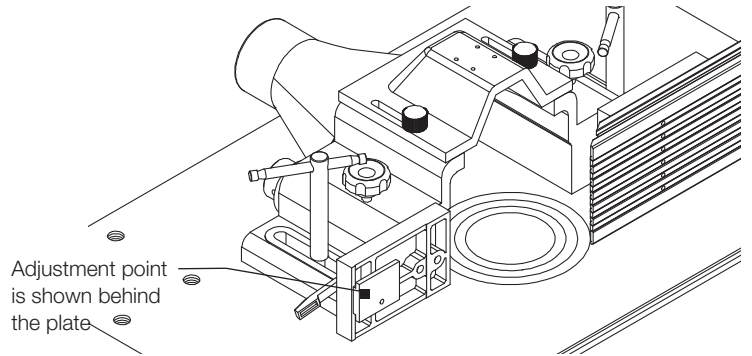

Moving fence assembly

The fence assembly is moved in an out to roughly align fence and move into the desired position.

To move the fence assembly, loosen locking handles located on top of the fence assembly until the fence assembly is in the desired position. Tighten the locking handles to secure.

Moving infeed and outfeed fences

Each fence half (infeed and outfeed fence) can be moved independently, in or out, depending upon the type of shaping operation to be performed.

To move fence(s) in or out, loosen one of the locking knobs and turn one of the adjusting knobs until the desired setting is obtained on the digital readout. Tighten the locking knob.

Aligning infeed and outfeed fences

- Place a solid steel ruler along the infeed and outfeed fences, adjust the fences so they are parallel to one another.

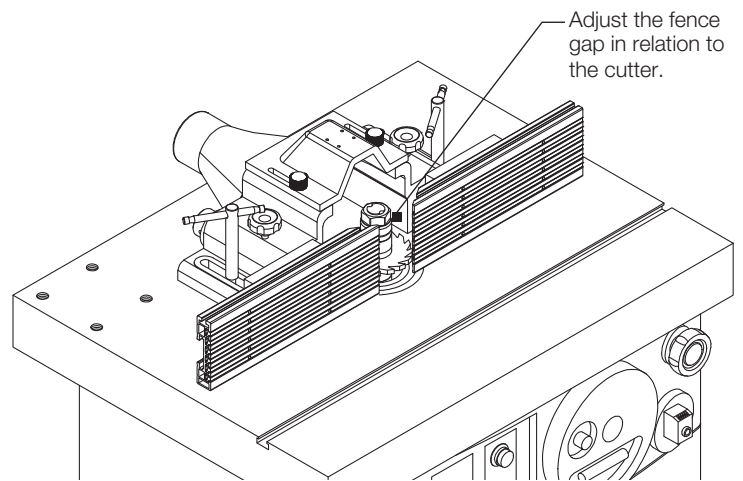
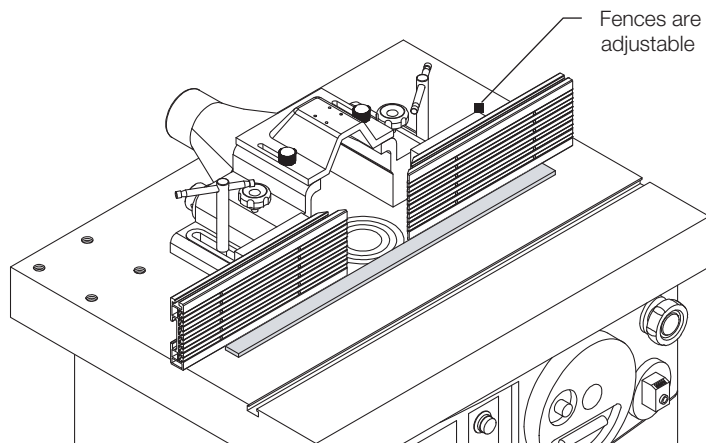

4.2 Spindle

PARTS REQUIRED:

- Spindle
- Drawbar

TOOLS REQUIRED:

- Spanner wrench
- Adjustable wrench

- Remove table rings for easy access to main shaft.
- To access the locking collar, use the handwheel on the front of the machine, raise the main shaft all the way to the top.
- Thread the short-threaded end of the draw bar into the threaded hole in the bottom of the spindle. This is the end without the 2 nuts and bevel washer.
- Remove the two lock nuts and bevel washer from the other end of the draw bar.
- Carefully insert the draw bar and spindle down through the shaft.

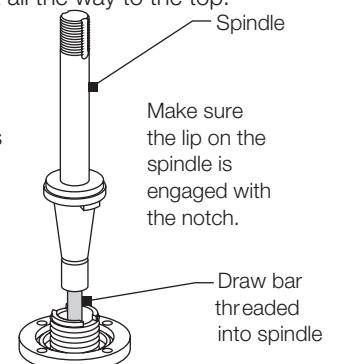

Make sure the lip on the spindle is engaged with the notch on the shaft. Open the front access door and hand tighten the 2 lock nuts and bevel washer on the bottom of the draw bar as shown in picture. Ensure the bevel washer is put on the draw bar before the 2 lock nuts. Tightening the drawbar will center the spindle.

- Engage the spindle lock. The spindle lock is provided to assist when changing the spindle or installing and removing cutters.

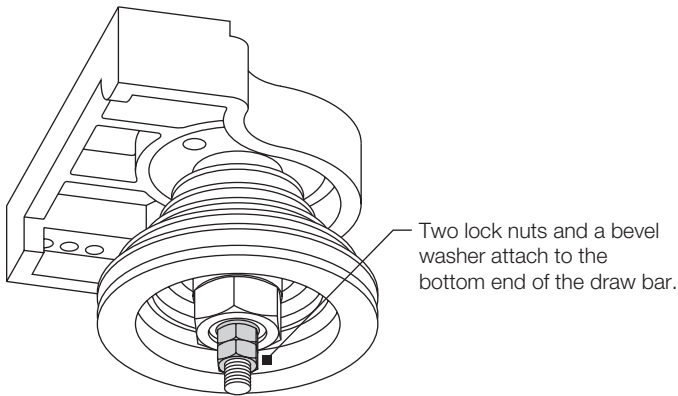

- To lock the spindle, turn the knob counterclockwise and push into the locked position.
- To unlock the spindle so it rotates freely, pull out the knob and turn clockwise. The knob will latch into the unlocked position.

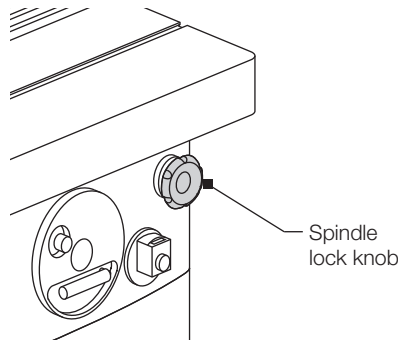

The manual lock has a limit switch to prevent the motor from starting when engaged.

- Securely tighten the two lock nuts with wrench.
- Thread the spindle safety nut onto the threads.
- Tighten the spindle safety nut, using the spanner wrench supplied with machine.

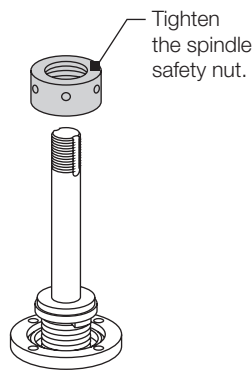

4.3 Cutter Head/Tooling

PARTS REQUIRED:

- Spacers
- Tool/cutter head (Not supplied. To source or for more information, contact Stiles Machinery.)

TOOLS REQUIRED:

- Spindle nut wrench

Install the cutter head or other tooling on the spindle.

⚠ WARNING

The cutter is extremely sharp. Use caution when handling or working with the cutter.

- Place the cutter head and spacers onto the spindle. Place the tool as close to the bottom of the spindle as possible.
- Attach the keyed washer on the spindle, making sure the washer engages the grooves on the spindle.

⚠ WARNING

Always place the keyed washer on the spindle before threading on the nut. The keyed washer prevents the nut from loosening when the spindle turns in a counterclockwise direction.

- Be sure that the top retaining nut and top spacer are in firm contact.

⚠ CAUTION

There must be no gap between the bottom of the retaining nut and the top of the uppermost spacer. Any gap that exists during operation could result in significant damage to the spindle.

- Attach and tighten the nut with all threads engaged using the provided spindle nut wrench.
- Disengage the spindle lock as explained in 4.2 Step 6.

⚠ CAUTION

The cutter should be positioned on the spindle so that the cut is performed from underneath the surface of the workpiece.

⚠ WARNING

After installing or replacing cutters and before operating the machine, carefully check to ensure that the direction of the cutter and keyed washer is correct, and that the spindle rings are directly underneath the spindle nut and securely tightened.

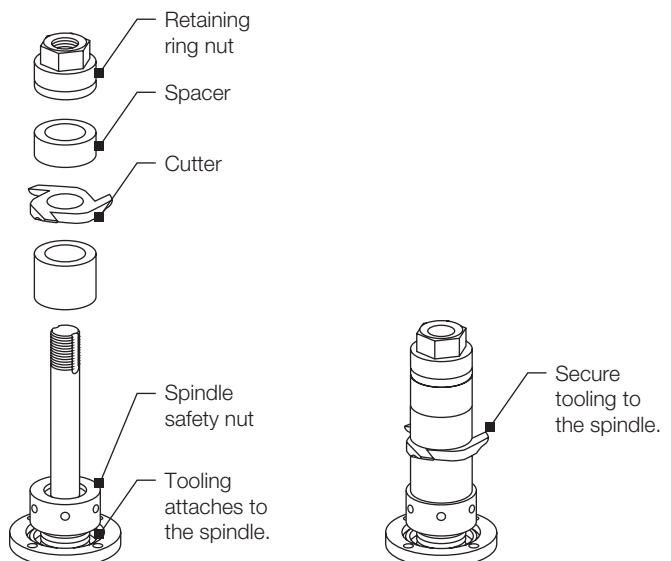

4.4 Top Dust Cover

PARTS REQUIRED:

- Dust cover assembly

TOOLS REQUIRED:

- Allen wrench

Assemble the top dust cover to the top of fence body using the two locking knobs and washers included in your attachment hardware pack.

WARNING

Do not operate the machine without the dust cover attached.

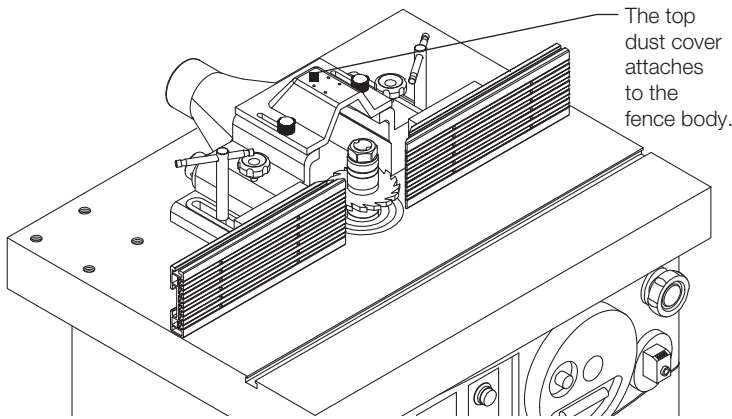

4.5 Safety Guard Assembly

WARNING

Always use the safety guard assembly and hold-down when operating the FX 550. Select and adjust the safety guard to the tooling currently being used.

PARTS REQUIRED:

- Safety guard assembly

TOOLS REQUIRED:

- Allen wrenches

1. Attach the guard base to the fence assembly body at the pilot hole locations using screws provided.
2. Attach a bracket to the vertical bar in the base, with the bracket facing the operator. Loosely attach the bar using an Allen wrench and set screw.
3. Loosely install a horizontal bar on the bracket. Loosely attach a bracket at the other end, with the bracket facing up. Loosely install the other horizontal bar so it extends toward the operator, beyond the fence. Attach two brackets with hand screws at the other end of the horizontal bar.
4. Attach the orange hold-down to the end of the inner vertical bar.
5. Attach the clear plastic safety guard to the outer vertical bar using set screws.

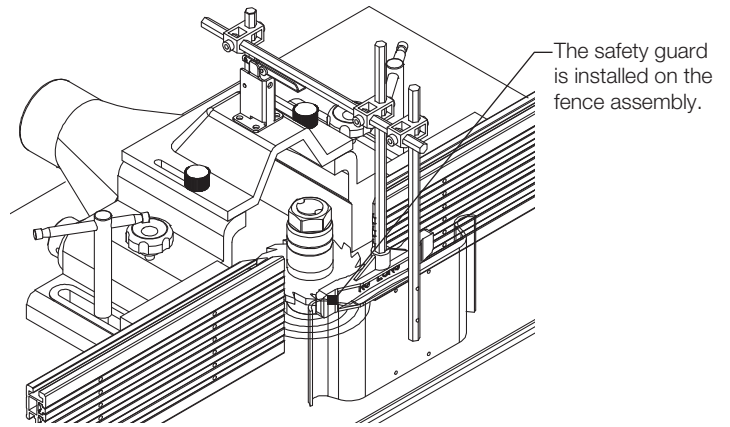
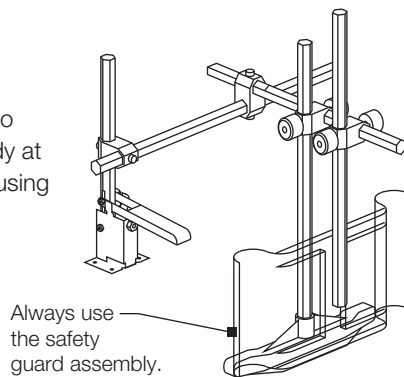

6. Once the safety guard assembly is configured as shown, tighten all set screws.

The safety guard hold-down assembly can be angled up out of the way using the adjustment lever.

4.6 Miter Gauge Assembly and Clamp

Use a miter gauge to make small or angled cuts.

PARTS REQUIRED:

- Miter gauge assembly

TOOLS REQUIRED:

- None

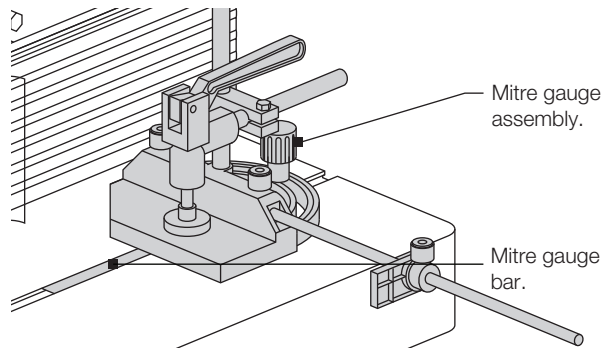

1. Angle the hold-down and safety guard up out of the way.
2. Locate the miter gauge bar and insert the bearing of the bar into the T-slot of the machine table.
3. Place the miter gauge on the bar, with the stud of the bar protruding up through the opening in the miter gauge body.
4. Fasten in place using washer and locking knob.

Stop Bar

1. Insert the stop bar into the hole on the side of miter gauge body, and lock into place with locking knobs.
2. Assemble the stop to the stop bar as shown in image above, and tighten the locking knob.

Clamp

A clamp is supplied with your miter gauge to securely hold workpieces. The clamp can be moved up or down as required.

5.0 Connect to Power

- Voltage – Steady state voltage +/- 10% of nominal voltage @230v +/- 10% of voltage @460v .
- Machine needs steady voltage at all times.

WARNING

Before connecting power to the machine, make sure all screws and fasteners are tightened, all mechanical functions work freely and the cutter turns freely without touching the table rings.

WARNING

All connections to electrical power should be completed by a licensed electrician.

Before connecting to a power source, confirm that the electrical current of the power source is the same as the electrical system supplied with your machine. Ensure the machine is protected with an external over current protective device per your local regulating authorities.

Machine must be properly grounded to prevent electric shock. Never connect the yellow/green wire to a live terminal.

Once connected to power source, terminals are electrified even while the power switch is off.

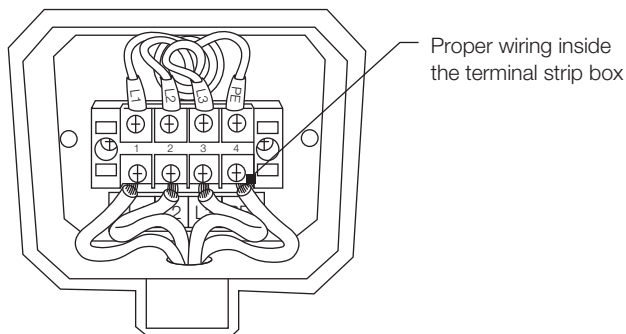

To connect source power to the machine:

1. Remove two screws and remove terminal box cover.
2. Remove clear plastic insulator that covers the terminals.
3. Insert source power cables through opening of terminal box.
4. Connect the three power cables to terminals L1, L2 and L3, and the yellow/green ground wire to ground terminal.
5. Replace the clear plastic insulator and the power box cover.
6. When wiring is complete, tape all terminal box joints to keep out dust and debris.

WARNING

Always shut off power at source before removing terminal box cover. Failure to comply with this action may result in electric shock.

CAUTION

We have covered some basic electrical requirements for the safe installation of your machine. These requirements may not cover all installation requirements. You must confirm that your particular electrical configuration complies with all local codes. Ensure compliance by checking with your local municipality and a licensed electrician.

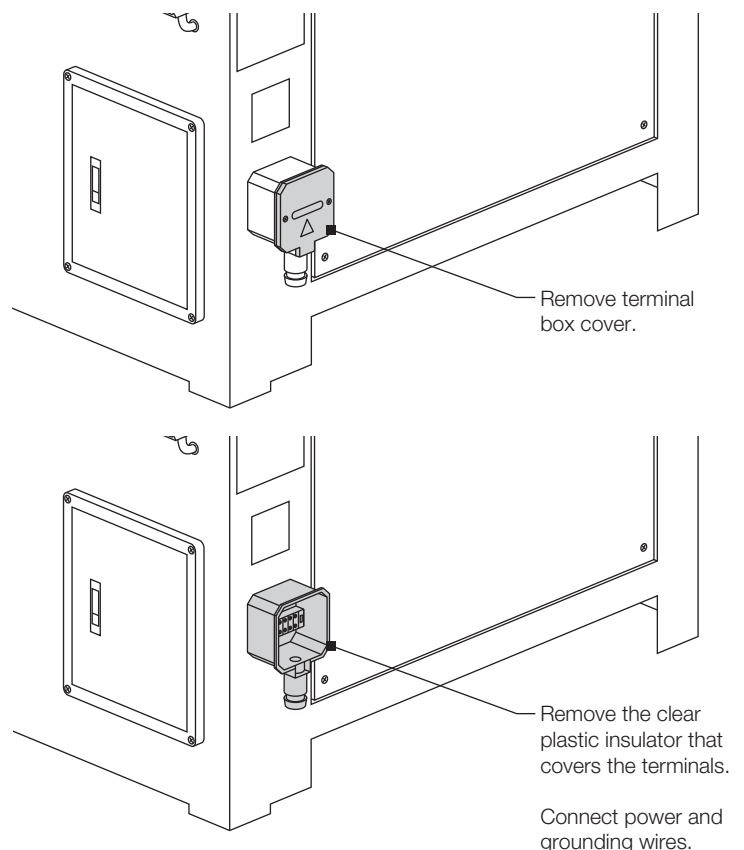

6.0 Safety

WARNING

Like all power equipment, there is danger associated with the Ironwood FX 550. Use caution and follow all safety instructions. Take every precaution to protect yourself, others around you, and the machine itself from improper use. Safety is a combination of common sense, training, and being alert at all times while operating your machine. If instructions, warnings, and cautions, are not followed, serious personal injury or death may occur.

EYE PROTECTION: Always wear approved safety glasses, or a face shield when operating this machine. Only use eye protection that meets or exceeds the standards of the American National Standards Institute (ANSI).

EAR PROTECTION: Always wear ear protection during machine operation.

DRESS CODE: Do not wear loose clothing, neckties, jewelry, or gloves that can get caught in moving parts. Confine long hair and keep sleeves above the elbow.

ELECTRICAL GROUNDING: Your machine must be electrically grounded. If a cord and plug are used, make certain the machine is properly grounded. Follow the grounding procedure indicated by the National Electric Code and local regulating authorities.

GUARDS: Make certain that machine guards are in place and in good working order. If a guard must be removed for any operation, replace it immediately following completion of that operation.

TOOLING AND ACCESSORIES: Use only recommended tooling and accessories. Improper tooling and accessories may cause damage to your machine or personal injury. Always run at the correct speed and feed rate. Never force a tool or accessory to perform a job for which it was not designed. Maintain your tools and accessories. Knives should be sharpened and cleaned for safe, optimal performance. Follow instructions for lubricating and changing tooling and accessories.

POWER: On machines equipped with a manual starter, make sure that the starter is in an "OFF" position before connecting power to machine or electrical maintenance.

Make certain the machine is either unplugged or electrically disconnected and locked out when performing all other maintenance, cleaning, or machine adjustments. Never leave the machine running unattended. Always turn the power off and stay by the machine until the cutterhead comes to a complete stop.

HOUSEKEEPING: Before turning machine on, remove all extra items on or around the machine. Keep the work area clean and free of scrap material, sawdust and other debris to minimize the danger of slipping. Use compressed air or a brush to remove chips or debris. NEVER use your hands.

7.0 Start the Machine

7.1 Control Panel

The control panel on the front of the machine handles all control functions. It has the following features:

- A. Speed indicator
- B. Emergency stop
- C. Forward/Reverse/Off switch
- D. Spindle Reverse light
- E. Control Power on Switch
- F. Control Power off Switch

7.2 On/Off

Use the following procedure to start or stop the machine:

1. Make certain that the spindle lock is disengaged and that the front access door is in the closed position.
2. Check rotation of spindle motor by turning motor on and off very quickly. Observe direction of rotation. If spindle rotation is backwards, do the following:
 - a. Turn power off to the machine.
 - b. Turn off main power supply / disconnect the machine.
 - c. Open terminal box, remove plastic covers and test with as multimeter to ensure there is no power at the machine.
 - d. Swap leads L1 and L2 to change phase rotation.
 - e. Reassemble terminal and plastic covers.
 - f. Turn on main power supply / connect the machine
 - g. Turn power on to the machine.
 - h. Repeat steps to check direction.

3. Rotate the Forward/Reverse/Off switch to either the forward or reverse rotation depending on tooling.
4. Push the Control Power On switch to start the machine.
5. To stop the machine, push either the Control Power Off button (preferred method), or turn the Forward/Reverse/Off switch to the middle.

In an emergency press the Emergency Stop button.

- a. When servicing the machine, press the power off button and turn the main on/off switch to 0, then place a sign on machine and install padlock on the main on/off switch before servicing it.

The electrical cabinet door must be closed except while servicing or troubleshooting.

⚠ WARNING

When opening the electrical door, make certain that the main power switch is shut OFF. Failure to comply with this action may result in electric shock.

7.3 Reverse Spindle Rotation

⚠ CAUTION

Never attempt to reverse the rotation of the spindle while the motor or spindle is in motion. Control power will drop out when the switch is turned to the middle/off position.

To reverse the rotation of the spindle, shut off the motor then rotate the forward/reverse/off switch after the spindle has come to a complete stop.

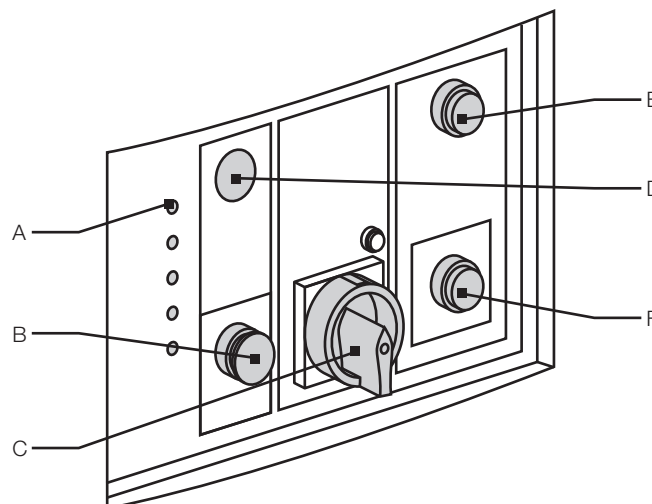

8.0 Operation

⚠ WARNING

Do not attempt to operate machine if you are not completely familiar with its operation. Obtain immediate advice from a supervisor, instructor, or other qualified personnel.

Use of this machine requires that you give your work your undivided attention, and careless acts or not paying close attention to work being performed may result in serious injury to yourself and/or others. Never operate this or any machine under the influence of drugs, alcohol, or any medication that may impair judgement.

SPINDLE: Make sure the direction of the spindle's rotation is correct. Start the machine to ensure it rotates in the correct direction. The rotation direction should correlate with the spindle rotation indicator light. The light is on only if the direction is in reverse. If the direction is incorrect, check the power phase sequence and have it corrected by a licensed electrician and see section 6.3.

Dust created by manufacturing activities may be harmful to your health.

Your risks from exposure may vary. Always work in a well-ventilated area and wear safety approved, protective dust masks specifically designed to filter out microscopic particles. Utilize wood dust collection systems appropriate to your machine type.

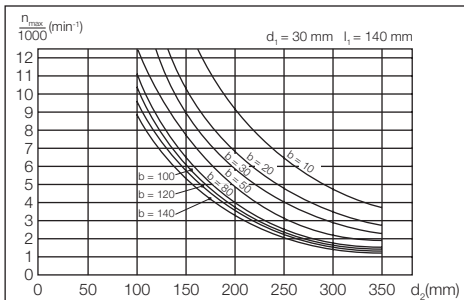
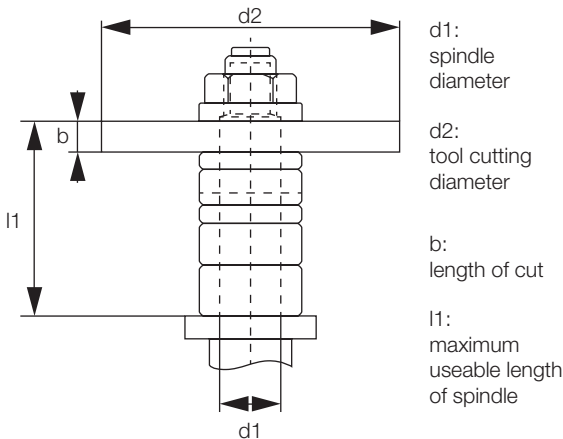

	10000 RPM
	8000 RPM
	6000 RPM
	4000 RPM
	3000 RPM

Spindle dia.	Tool length
30 mm	140

AVOID KICKBACK: It is very important that each workpiece be carefully inspected for stock condition and grain orientation before running through the machine. “Pull-out” and the danger of kicked back material can occur when the workpiece has knots, holes, or foreign materials such as nails. It can also occur when the material is fed against the grain on the shaper. The grain must run in the same direction you are cutting.

Use of a power feeder greatly reduces the risk of kickback.

⚠ CAUTION

During certain applications, it may be necessary to shape against the grain. This application requires that the operator use a shallow depth of cut and a slower feed rate.

8.1 Speed Change and Belt Adjustment

Confirm that the selected spindle speed matches the suggested spindle speed provided by the tooling manufacturer.

Before operation, check that all tools are sharp, are the correct tool for the work to be performed, properly maintained and adjusted according to the tool manufacturer's instructions.

There is a relationship between tool diameter, cutting length, and maximum rotation speed.

The maximum safe spindle speed depends on:

- Spindle diameter
- Usable length of spindle
- Length of cut
- Tool cutting diameter
- Tool specifications per the spindle manufacturer

The following charts can be used as a reference guide for the maximum spindle speed for various tool cutting diameters given the values of d, l, and b. Always refer back to the ratings provided by the tool manufacturer.

Reminder: Always place the tool as close to the bottom of the spindle as possible.

The FX 550 machines are supplied with a 5-step motor pulley and a 5-step spindle pulley that provides spindle standard speeds of 3000, 4000, 6000, 8000 and 10,000 RPM.

A chart (Label 6) is located on the inside of the access door for easy reference of the belt position on the pulleys for the five speeds available.

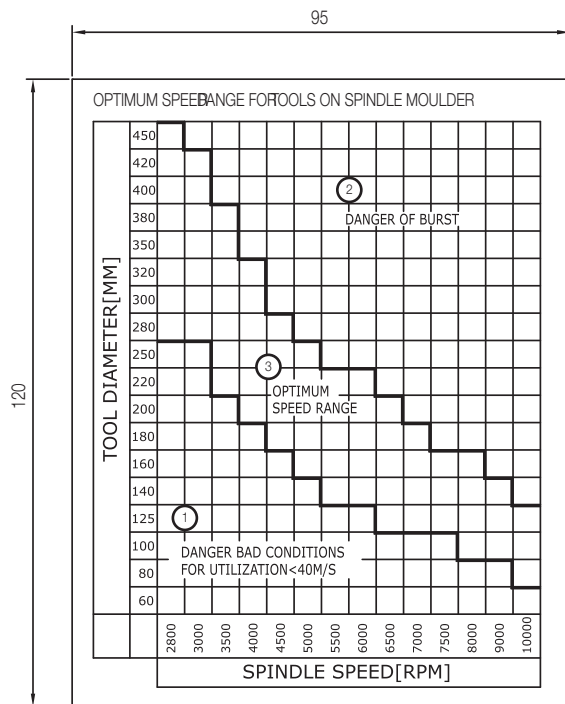

1. Hazard: bad machining conditions
2. Bursting hazard
3. Recommended spindle tool speed

Confirm the machine's speed settings before operating. Make certain that the cutter meets or exceeds speed rating of tool. The diagram is an example of choosing a speed in relation to the diameter of the tool, and the most appropriate peripheral speed for the type of material that is being worked on. Always refer back to the ratings provided by the tool manufacturer.

Cutting speed should always be sufficient to prevent kickback risk, but never fast enough to cause tool damage.

The cutting speed range m/sec (lower and upper) is selected according to the tool diameter (mm) D (left vertical axis), and the tool spindle speed N min⁻¹ (bottom horizontal axis).

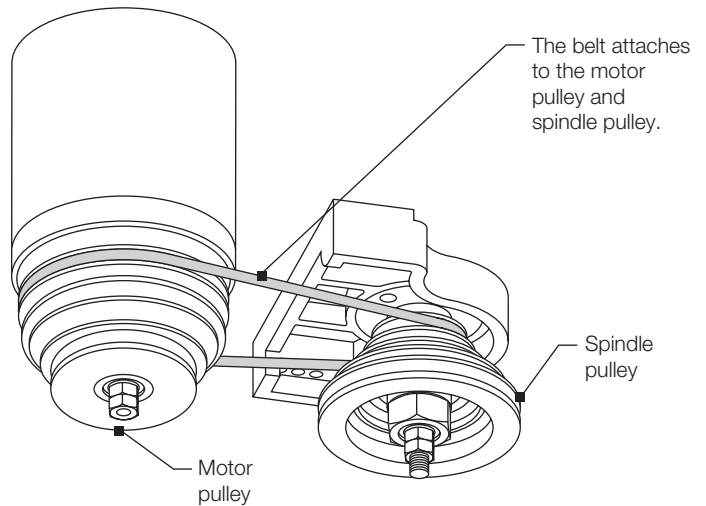

Guide values for cutting speed

Material	Cutter HS (m s ⁻¹)	Cutter HW (m s ⁻¹)
Softwood	50-80	60-90
Hardwood	40-60	50-80
Chipboard	—	60-80
Coreboard	—	60-80
Hard fibreboard	—	40-60
Plastic-coated board	—	40-60

Example:

Cutter: 160 mm diameter, $v_c = 76 \text{ m s}^{-1} \rightarrow n = 9000 \text{ min}^{-1}$

Cutter speed formula:

$$v = (D \times \pi \times N) / (60 \times 1000)$$

D: Tool diameter (mm)

N: Tool spindle speed (rpm)

⚠ WARNING

Always operate a tool at the speed range set by the manufacturer. Failure to do so may result in serious injury or machine damage.

To change the speed and adjust to proper belt tension:

1. Disconnect the machine from its power source.
2. Open the access door. NOTE: A limit switch is provided which prevents the machine from being turned on when the access door is open.
3. The belt can be moved to the desired steps of the motor pulley and spindle pulley. To loosen belt tension, move the belt tension lever to the right. At the same time, rotate the knob to slide the speed bar up or down so that the belt will be positioned in the cut-out in speed bar.
4. After the belt is positioned as desired, move the tension lever to the left to apply tension to the belt.
5. Close and latch the access door.

Note: After a short time, the belt may stretch. Check tension by pressing the center of the belt with a force of 6.6 lbs (3 kg.) Tension is correct when $\frac{3}{16}$ " (5mm) of deflection is observed. Turn the two nuts to adjust best belt tension.

Never place the V-belt under excessive strain, as this can overload the motor and damage the bearings, spindle or belt.

8.2 Spindle Height Adjustment

Adjust spindle height to achieve the desired cut. The spindle height can be precisely measured using the digital readout feature.

1. Loosen handwheel lock and spindle locking lever.
2. To raise the spindle, turn handwheel counterclockwise and to lower the spindle, turn handwheel clockwise.
3. Note: One complete turn of the handwheel moves the spindle up or down by 1mm or 2.5 mm indicated on the machine frame (sticker).
4. Tighten handwheel lock and spindle locking lever when desired spindle height is obtained.

8.3 Using Fence(s)

⚠ WARNING

Keep guards in place and in working order. Always use the fence assembly when work permits.

Using the fence is the safest and most accurate method of shaping, and should always be used when work permits. The majority of straight work can be performed using the fence.

For normal work, where a portion of the original edge of the stock is not touched by the cutter, both the infeed and outfeed fences are in a straight line.

When the shaping operation removes the entire edge of the workpiece, e.g. in jointing or making a full bull nose, the shaped edge will not be supported by the outfeed fence edge when both

fences are in line. In this case, the workpiece should be advanced to the position shown and stopped. The outfeed fence should then be moved forward to make contact with the workpiece. The outfeed fence will then be in line with the cutting circle, and the operation can continue.

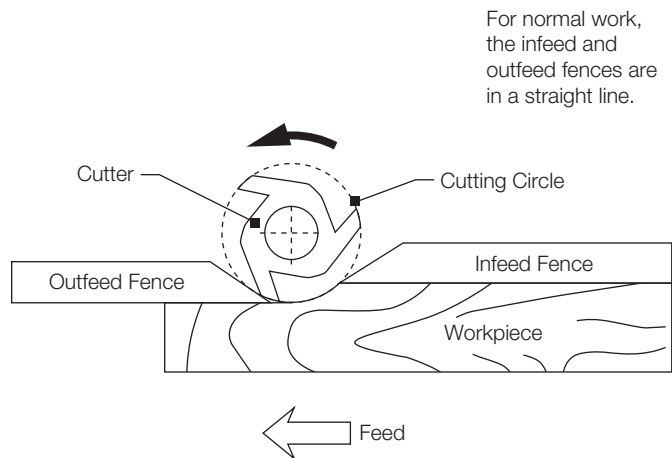
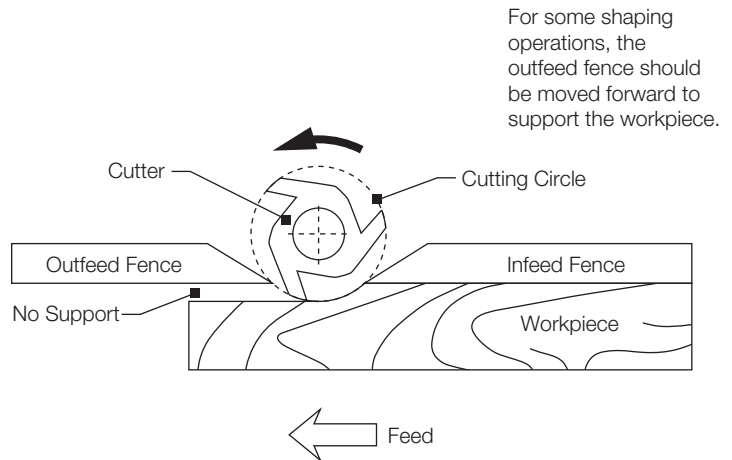

Note: All Ironwood shapers accommodate Stiles power feeders. Power ports are included on the rear of the machines. For more information review operators instructions included with the power feeder or contact Stiles machinery.

8.4 Adjusting Fence Extensions

⚠ WARNING

To eliminate gaps between the edges of the fence and cutter, both fences should be adjusted as close to the cutter spindle tooling as possible.

For added safety, the fence extensions can be adjusted to the height of the cutterhead so that you expose only the amount of tool required to make a safe cut is exposed.

Using an Allen wrench, loosen the aluminum fence extensions, slide them horizontally into desired position, and tighten.

8.5 Positioning and Using Collars

When shaping with collars, the collar must have sufficient bearing surface. Also, the workpiece must be fairly heavy relative to the cut being made.

The collars may be used above, below, or between the cutters.

Under no circumstances should you shape a short or light workpiece against the collars.

When the collar is used below the cutter, the progress of the cut can be seen throughout the operation. However, any accidental lifting of the workpiece will gouge the product and ruin the workpiece.

When the collar is used above the cutter, the cut cannot be seen, but this method offers an advantage: the cut is not affected by light variations in the thickness of the workpiece. Also, accidental lifting of the workpiece will not gouge the work piece; simply repeat the operation to correct the mistake.

Using the collar between two cutters has advantages and disadvantages of the first two procedures, and is frequently used where both edges of the work are to be molded.

Note: Place the cutter as low as possible on the spindle to reduce spindle deflection and ensure the best possible finish. Also, make sure that the contacting surfaces of the cutter are smooth, clean, and without dents.

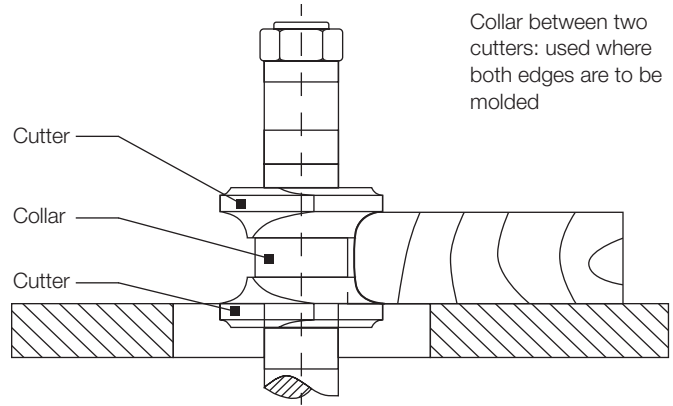
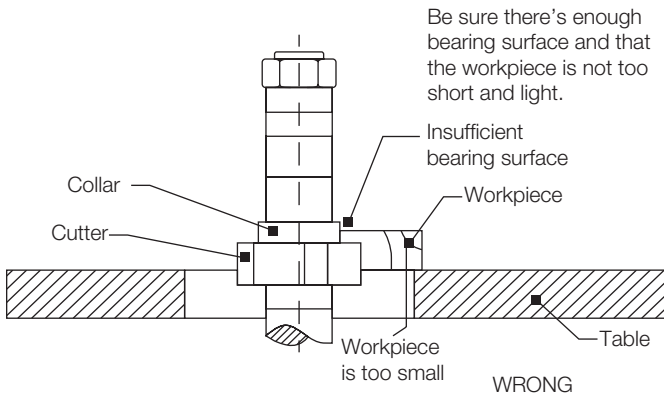
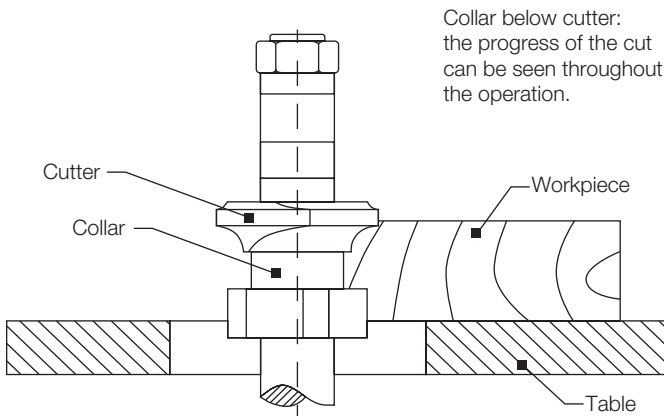

8.6 Tenoning

⚠ WARNING

Keep guards in place and in working order.

The miter gauge and clamp provided with the machine can be used for tenoning operations.

If your machine is equipped with a tenoning carriage, the tenoning hood fitted with adjustable sections is used to guard the tool from above the workpiece and from the sides.

Various tenoning carriages are available. For more details contact Stiles Machinery.

8.7 Tool Adjustments

⚠ WARNING

Tools are extremely sharp. Be careful when working with tooling as serious injury may occur.

⚠ CAUTION

Always disconnect the machine from its power source before making any adjustments.

To reduce kickback, use only tools that conform to EN 848-1:2005 and EN 848-2:2001, and that are marked MAN.

Refer to the tool manufacturer's recommendations for clamping and setting of tools.

To ensure safe and efficient cutting, the tooling should be suitable for the material being cut. The tools should be sharp and properly set with carefully balanced tool holders.

Use extra precautions when handling tools and always use tool carriers.

8.8 Noise Reduction

- Always use hearing protection.
- Make sure tooling is in proper working condition.
- Properly position material and guards.
- Use proper tooling speed.

9.0 Maintenance

WARNING

Never operate the machine until it has been properly lubricated and all necessary maintenance work has been completed.

Before performing any type of maintenance or adjustment, make certain that the machine is shut off and disconnected from its power source.

9.1 Lubrication

It is important to periodically apply a drop of light machine oil on the ledge and walls of the table opening to aid in the changing of table rings. Note: Do not get oil on the pulleys or belts.

The bearings in the motor are sealed for life and do not require lubrication.

The spindle bearings require lubrication every 200 hours of use.

To lubricate, use the grease gun provided with the machine:

1. Locate the two grease fittings positioned opposite each other on the spindle housing.
2. Clean the fittings thoroughly.
3. Lubricate using two pumps of the grease gun in each fitting.
4. Clean off any excess grease.

9.2 Inspection

CAUTION

After changing a setting, making an adjustment, performing repair, maintenance or troubleshooting, check that all safety functions are working properly before restarting machine.

9.3 Periodic Maintenance

Periodic cleaning increases the life of the machine and enhances performance. Vacuum the inside of the machine as wood shavings, dust or other debris will accumulate.

To replace ball bearings, contact Stiles Machinery's Parts Dept at 1-800-727-8780.

Feature	Interval/Situation
Spindle ball bearings	Lubricate every 200 hours of use.
Belt	Replace every 1,000 hours of use or whenever it becomes frayed.
Emergency stop	Every day. Press to check prior to operation.
Interlocked guards (door lock, spindle lock)	Monthly. Open each guard one at a time to stop the machine. Confirm machine will not start with each guard in the open position.
Mechanical brake	Every 100 hours of operation or by doing a brake function test to check that the machine stops within the specified time (less than 10 sec.)
Electrical cabinet/system	Monthly. Inspect for loose wiring terminals and insulation deterioration.
Spindle	Every day. Clean spindle and main shaft with compressed air daily.
Pulleys and Belts	Monthly. Inspect for wear and proper tension.
Table Surface	Monthly. Wax table surface to prevent rust and lubricate for easy panel movement.

10.0 Troubleshooting

Trouble	Possible Cause	Solution
Machine will not start.	Fuse is blown or circuit breaker is tripped. Cord is damaged. Access door is open. Spindle lock knob not released.	Replace fuse or reset circuit breaker. Have cord replaced by authorized service personnel. Close door or guard(s). Release spindle lock.
Spindle overload trips frequently.	Feeding stock too quickly. Cutter is dull or has debris build up on it. Bad bearings (rotate spindle to check). Check voltage to motor.	Feed stock at a slower rate. Clean or replace cutter. Replace bearings or spindle. Replace relay. Check gauge of incoming power line.
Tool does not come up to speed.	Low current / voltage. Motor is not wired for the correct voltage. Spindle is locked.	Contact licensed electrician. Check for correct motor wiring. Check or replace spindle lock knob.
Machine is making insufficient cuts.	Dull tool. Dirty tool. Dirty table causing erratic feed. Feeding workpiece in wrong direction. Tool rotation wrong direction.	Replace tool. Remove tool and clean with turpentine and steel wool. Clean table with turpentine and steel wool. Feed workpiece against tool rotation. Check spindle rotation direction.
Stock burns.	Dull tool. Cutter too deep. Forcing workpiece too fast.	Sharpen or replace tool. Make shallow cuts. Make a full depth cut with several passes. Feed slowly and steadily.
Machine vibrates excessively.	Damaged tool. Machine not level. Worn v-belt. V-belt does not have proper tension. Bent pulley. Improper motor mounting. Spindle bearings.	Replace tool. Reposition on flat, level surface. Replace v-belt. Adjust belt tension. Replace pulley. Check and adjust motor mounting. Replace spindle bearings.
Edge splits off on cross-grain cut.	Quality of cut. Improper or dull tooling. Improper wood moisture content.	Make cross-grain cuts first then finish with grain. Use scrap block to support end of cut. Replace or sharpen tooling. Humidify building / increase wood moisture content.
Raised areas on shaped edge.	Variation in workpiece pressure against cutter.	Keep work firmly against fence or collars throughout pass. Use a hold down device or power feeder.
Workpiece pulled from hand when cutting.	Not properly supported.	Use a miter gauge with a hold down device to start when performing a freehand cut; hold workpiece firmly against the fence. Adjust the tension of the spring plate. Use power feeder.
Depth of cut is not even.	Fences out of alignment. Side pressure is not even.	Adjust fences. Use hold-down device; keep consistent pressure against the fence or collars.
Variation in height of cut.	Variation in workpiece down pressure on table.	Keep pressure firm throughout pass. Use a hold down device or power feeder. Make pass slowly and steadily. Keep cutter under workpiece.
Uneven cuts. (Cuts not smooth)	Wrong cutter speed. Feeding stock too quickly. Working against the grain. Cutting too deep.	Use faster speed. Feed stock at a slower rate. Work in the direction of the grain whenever possible. Make several passes on deep cuts.
Spindle does not raise freely.	Sawdust, dirt or other debris stuck in raising mechanisms. Worn shaft/gear/sleeve worn.	Brush or blow out loose dust, dirt and other debris. Call Stiles service.

If you cannot resolve your issue, contact Stiles technical support at 616.698.6615.

10.1 Electrical Diagram

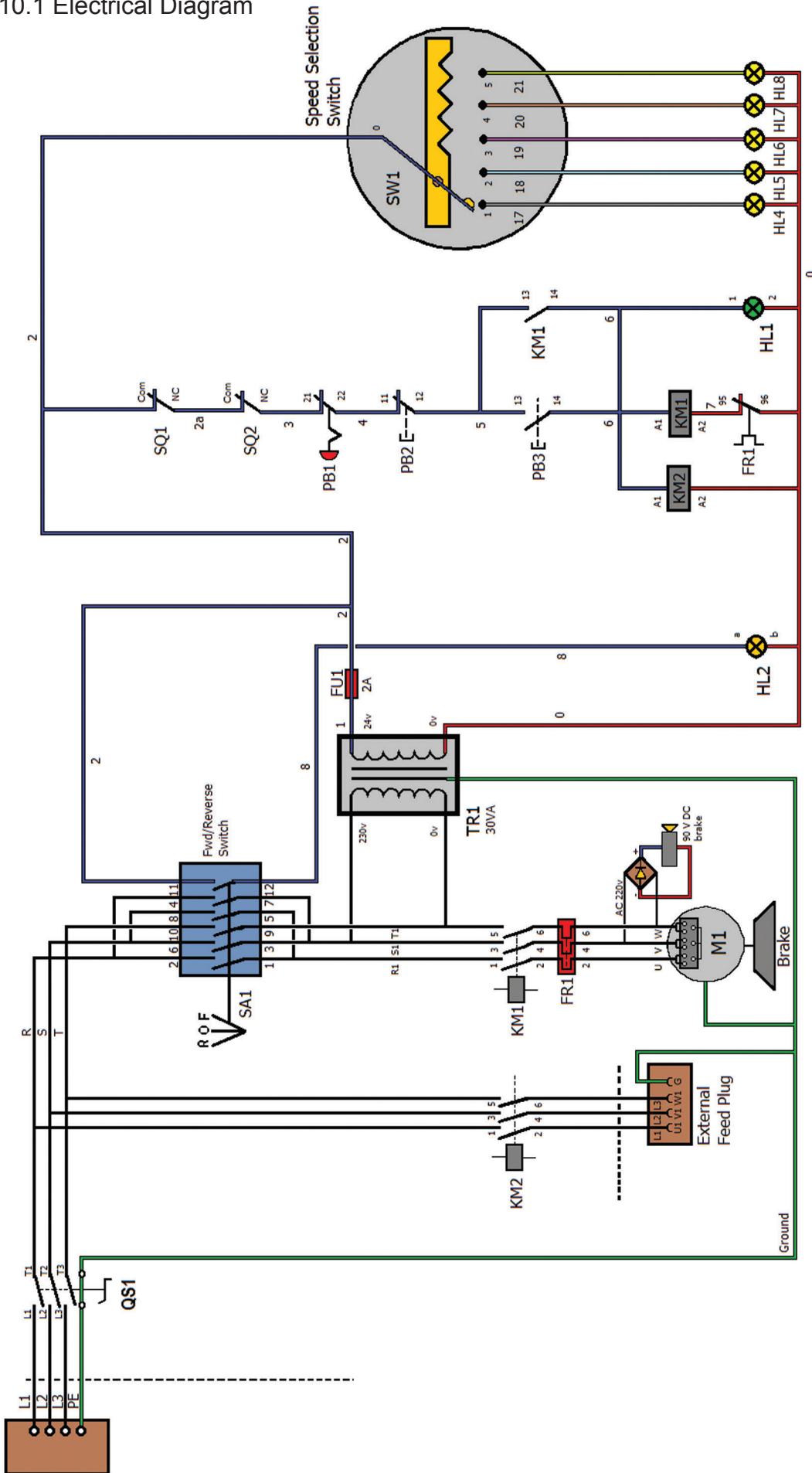

IRONWOOD

Version A
September 2013

© 2013 Stiles Machinery Inc.

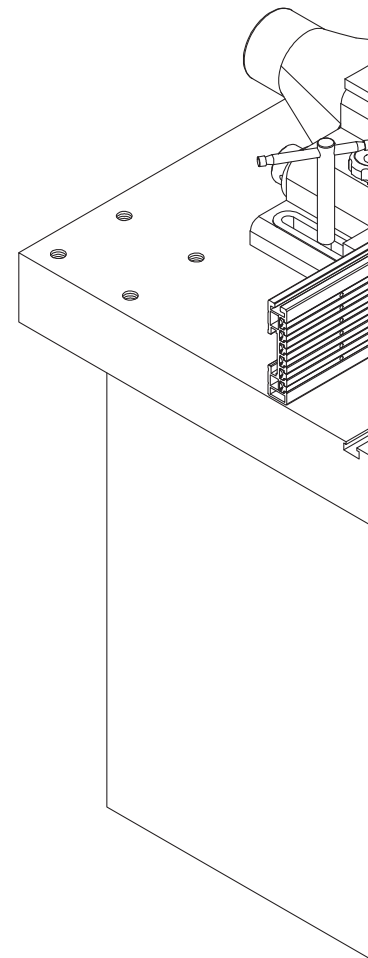

stiles

Stiles Machinery Inc.
3965 44th St. SE
Grand Rapids, MI 49512
p. 616.698.7500
f. 616.698.9411
www.stilesmachinery.com