

Ironwood CUT 14

User Manual

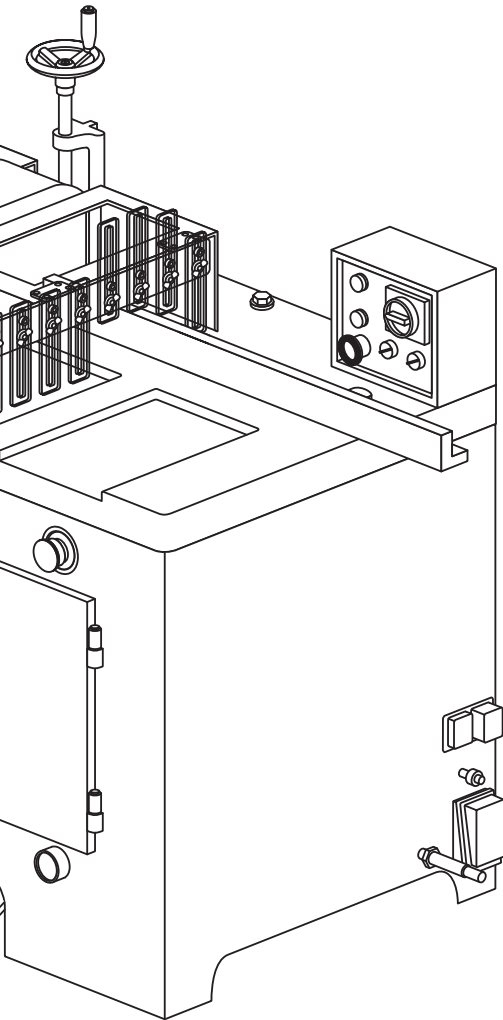

general information. features.

technical specifications. safety considerations.

delivery and installation. inspection.

receiving the machine. **assembly.**

connect to power. **safety.**

dust exhaust outlet. **operation and adjustments.**

adjust air pressure. cutting the workpiece.

maintenance. adjust v-belt tension.

troubleshooting. electrical diagram.

IRONWOOD

stiles

Table of Contents

1.0	General Information	3
1.1	Thank You!	
1.2	Before Contacting Stiles	
1.3	Features	
1.4	Intended Use	
1.5	Technical Specifications	
1.6	Safety Considerations	
2.0	Facility Preparation	6
2.1	Floor	
2.2	Work Space	
2.3	Power	
3.0	Delivery and Installation	7
3.1	Receiving Your Machine	
3.2	Unpack the Machine	
3.3	Inspection	
3.4	Move Machine to Final Position	
3.5	Remove Machine from Pallet	
3.6	Level	
3.7	Pre-Operation Cleaning	
4.0	Assembly	10
4.1	Saw Blade	
4.2	Dust Exhaust Outlet	
4.3	Safety Guard Assembly	
5.0	Connect to Power	12
6.0	Safety.	13
7.0	Operation and Adjustments	14
7.1	Control Panel	
7.2	Emergency Stop	
7.3	Pneumatic Control	
7.4	Adjust Hold-Down Clamp	
7.5	Adjust Air Pressure	
7.6	Adjust Fence Squareness to Saw Blade	
7.7	Cutting the Workpiece	
8.0	Maintenance.	18
8.1	Cleaning	
8.2	Lubrication	
8.3	Change the Saw Blade	
8.4	Adjust V-Belt Tension	
8.5	Replace V-Belts	
9.0	Troubleshooting	20
9.1	Air Circuit Diagram	
9.2	Electrical Diagram	

 **PLEASE REVIEW AND OBSERVE ALL SAFETY INFORMATION / DIRECTIVES BEFORE INSTALLING, OPERATING, OR PERFORMING MAINTENANCE ON THIS MACHINERY.**

1.0 General Information

1.1 Thank You!

Thank you for your purchase of the Ironwood CUT 14 cut-off saw. At Stiles Machinery, our goal is to ensure that you are fully satisfied with your purchase. This manual is provided so that you may properly assemble, operate, and maintain your CUT 14. Should you need help, our team of dedicated service personnel are available to answer your questions and provide any resource recommendations you may need.

Warranty and Support

All Ironwood machines are designed to meet the exacting standards demanded by craftsmen like you. Ironwood machines include a one (1) year parts warranty and two (2) years of free 24/7 technical support beginning at date of shipment. Standard technical support remains in effect for free for the lifetime of the machine thereafter. Warranty service work is not covered by manufacturer's warranty. Stiles' service team is available for an additional charge.

1.2 Before Contacting Stiles

Please have your machine model and serial number available when contacting Stiles Machinery with questions. The machine's model and serial numbers are listed on the metallic plate located on the machine's frame.

Information regarding the electrical system and pneumatic supply are also listed on the metallic plate.

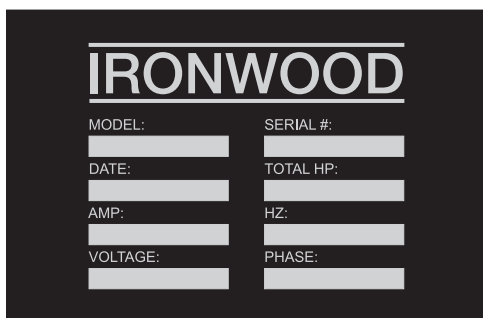

Stiles Technical Support
616.698.6615

Stiles Parts
800.PARTS.80 (800.727.8780)

Website
www.stilesmachinery.com/ironwood/cut14

Machine Model _____

Machine Serial Number _____

1.3 Features

- A convenient foot pedal, or dual push buttons (depending on saw configuration) controls the pneumatic operation of the cutting cycle; air pressure is used to raise the saw blade and lower the hold-down clamp.
- Solid steel construction and a precision ground table surface ensure cutting accuracy and stability during heavy cutting operations.
- Accommodates an 14" saw blade.
- Cutting capacity: up to 3" thick and 10" wide. See section 7.4 for cutting capacity chart.
- Powerful, high-torque, 5-hp motor provides stability at fast cutting speeds.
- Safety guard improves operator safety.
- 4" diameter dust extraction port keeps work area clean.
- Hold-down clamp adjusts to workpiece thickness.
- Doors are locked and unlocked only with a special unlocking handle.

1.4 Intended Use

Use your CUT 14 for accurate, safe, and reliable wood crosscutting for workpieces up to 3" thick and up to 10" wide. Rugged cast iron construction and powerful motor ensure stability for heavy cutting operations.

Performance and dependability are optimized when the machine is operated with care and maintained properly. When used according to the instructions in this manual, you can expect years of trouble-free operation.

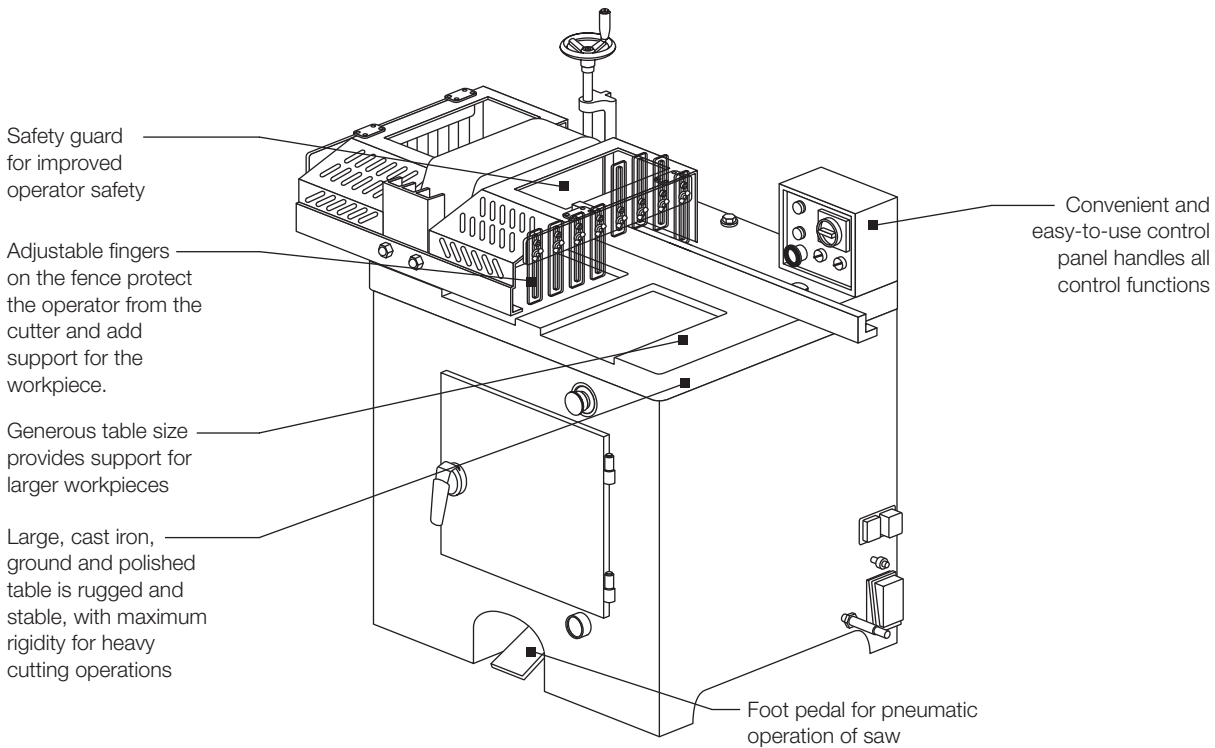

1.5 Technical Specifications

Description	Ironwood CUT 14
Cutting capacity (thickness x width)	1" x 10", 2" x 9", 3" x 8" (25mm x 254mm, 51mm x 229mm, 76mm x 203mm)
Cycle speed	95 cpm (cuts/min)
Cycle operation	Pneumatic
Air pressure requirement	70-80 psi
Air consumption	17 cfm
Saw blade size	14" (355mm)
Saw arbor diameter	1" (25.4mm)
Saw blade speed	4,100 rpm
Dust port diameter	4" (102mm)
Dust extraction requirements	450 cfm @ 4,500 feet/min.
Motor	5 hp
Power	230 v (3 phase) 460 v (3 phase)
Amperage	11.4 amps (@ 230 v) / 5.7 amps (@460 v)
Table size	25" x 23" (630mm x 590mm)
Working table height	34" (860mm)
Net weight	542 lbs. (245 kgs)
Gross weight	640 lbs. (290 kgs)
Packing dimensions (L x W x H)	30" x 30" x 45" (760mm x 760mm x 1,150 mm)

1.6 Safety Considerations

For your safety, read these instructions thoroughly before you install and operate this machine. Always have these instructions available at the machine for reference.

Observe all codes and regulations that apply to the installation and operation of this machine.

Keep visitors at a safe distance from the workspace.

Keep children away from this and all machines. Childproof your work area!

Familiarize yourself with the safety notices used in this manual.

CAUTION

If cautions are ignored, personal injury and/or machine damage may result.

WARNING

If warnings are ignored, serious injury or death may result.

Warning Labels

This machine has warning labels attached to ensure safe operation. These warning labels are very important and should be kept clean and never be removed. If warning labels become damaged or lost, contact Stiles Machinery immediately for replacements.

Label 1 Keep hands out of this area

Label 2 Do not operate the CUT 14 when the saw blade access door is open

Label 3 Always wear ear and eye protection

Label 4 Safety instructions for operating the CUT 14



WARNING

Never use the CUT 14 for purposes other than its intended use. Do not modify or remove any guards or other safety features. Improper use or modifications may affect your warranty or result in serious injury or death.

Training

This machine is intended for use by authorized, well-trained operators only.

Do not operate this machine until you have a complete working knowledge of this saw and have been properly trained for its safe operation, correct adjustment, and use. All operators should thoroughly read and understand this manual and the workings of this machine prior to operation.

It is essential that all operators be aware of the following:

- The dangers associated with the operation of this machine.
- The use of personal protective equipment for ear and eye protection.
- The proper positioning of the operator and operator's hands relative to the saw blade and pneumatic hold down clamp.
- The principles of machine operation, and proper use and adjustment of the fence, jigs, safety guards, extension tables and end stops.
- The correct selection of tooling for each operation.
- The safe handling of the workpiece when cutting.
- The safe stacking of the workpiece before and after cutting.

NOTE: Dust extraction equipment must be connected and turned on before starting all machine operations.

2.0 Facility Preparation

Prior to uncrating your machine confirm that your location can accommodate the Ironwood CUT 14. Follow these guidelines:

2.1 Floor

- The floor must be flat and level.
- Although no special foundations are required, a concrete floor is recommended.
- All floors must have a load-bearing strength suitable for the machine weight of approximately 600 pounds.
- The machine need not be anchored to the floor. However, if you decide to do so, purchase high quality anchor bolts appropriate to the floor construction and material.

2.2 Work Space

- Provide adequate work space surrounding the machine.
- Provide proper non-glare, overhead lighting to keep the work space well lit.
- Place the machine so that any potential kickback area is not in line with aisles, doorways, or other work and traffic areas.
- Provide an adequate dust extraction system. The dust extraction system should have a flow rate of 4500 feet/min at 450 cfm.
- Avoid exposure to any environment where vibration is present.
- Avoid exposure to direct sunlight or heat.

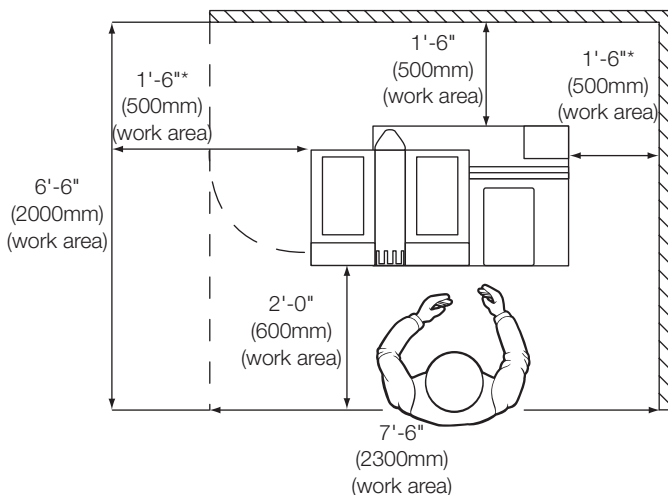

Machine clearance requirements*

*Actual clearance requirements may vary depending on length of material to be cut.

2.3 Power

⚠ WARNING

A licensed electrician must connect the CUT 14 to the building power source.

- Do not use extension cords.
- Be sure that the electrical current of the power source is of the same characteristics as the electrical system supplied with your machine. If other machine voltage capabilities are required, contact Stiles Machinery.
- Provide access to a suitable power source.

	CUT 14
Motor	5 HP
Motor Power	230v (3 phase) / 460v (3 phase)
Amperage	11.4 amps (230v) / 5.7 amps (460v)

- Ensure the machine is protected with an external over-current protective device per your local electrical codes.
- Electrical equipment operating conditions:
Air temperatures between +41°F (+5°C) and +113°F (+45°C).
Relative humidity not to exceed 50% at a maximum temperature of +113°F (+45°C).
- Electrical equipment is designed and protected to withstand the effects of transportation and storage temperatures within a range of -13°F (-25°C) to +131°F (+55°C), and for short periods of time not exceeding 24 hours at up to +158°F (+70°C).
- Ensure connection to factory ground system is wired correctly (according to IAW local electrical codes and National Electric Code) and not connected to any electromagnetic interference source such as welders.

3.0 Delivery and Installation

3.1 Receiving Your Machine

You will be contacted to arrange delivery. Your machine will be delivered by truck to your location. If there is no loading dock, be sure that you have informed the carrier in advance so that they deliver using a truck with a lift gate to lower the machine to ground level.

Before accepting the machine and signing the bill of lading from the carrier, please inspect crating and machine condition, note potential damage on the bill of lading, take pictures of potential damage, and contact Stiles Machinery immediately at 616.698.7500 and ask to speak with the traffic department.

The machine will arrive fully crated and secured to a pallet. Use a hand truck or fork lift to move the machine on its pallet as close to its final position as possible.

If you do not intend to install the Ironwood saw immediately after delivery, store it in a protected, cool, and dry location.

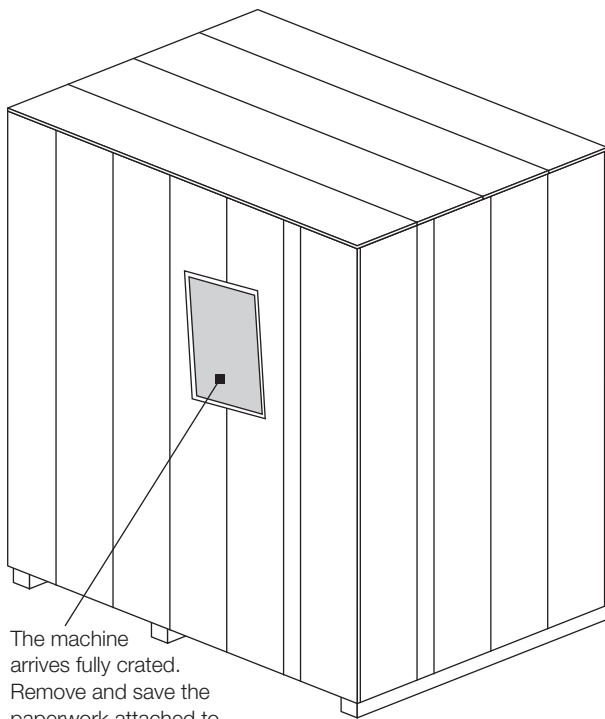

The machine arrives fully crated. Remove and save the paperwork attached to the outside.

3.2 Unpack the Machine

TOOLS REQUIRED:

- Hammer
- Crowbar

Unpack as follows:

Do not remove the machine from the pallet.

1. Remove and save all paperwork attached to the outside of the crate.
2. Remove the crating, starting with the top, then remove the four sides. Use caution to avoid personal injury and prevent damage to the machine's finish.
3. Remove the protective plastic from the machine, starting at the bottom.

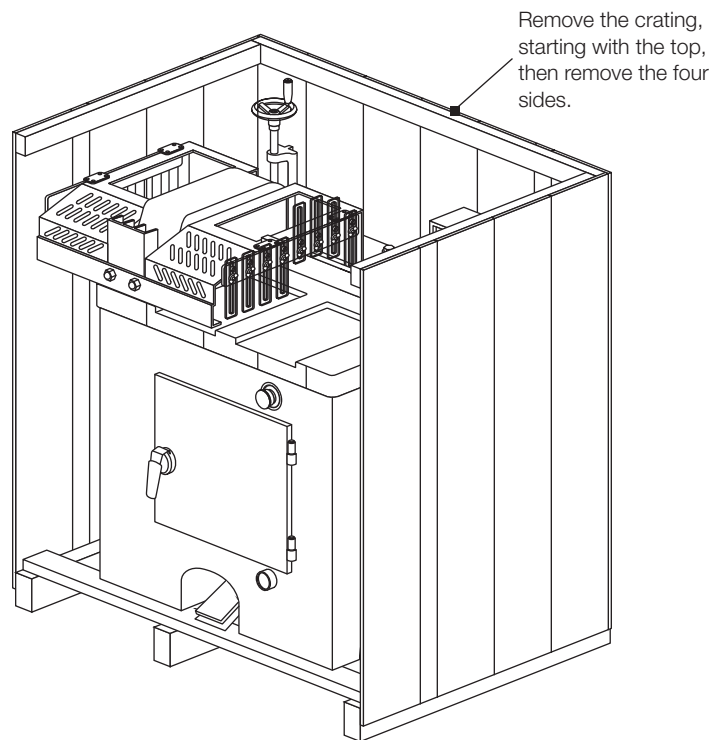

Remove the crating, starting with the top, then remove the four sides.

4. Remove the plastic sleeve from the front access door handle. The door is locked when the handle is in the vertical position. Turn the handle to the right to unlock and open the access door.

- Remove the hardware, accessories, and a tool kit that are shipped with the machine, noting that some hardware and accessories may be located inside the machine. If additional accessories are ordered, they may be delivered separately.

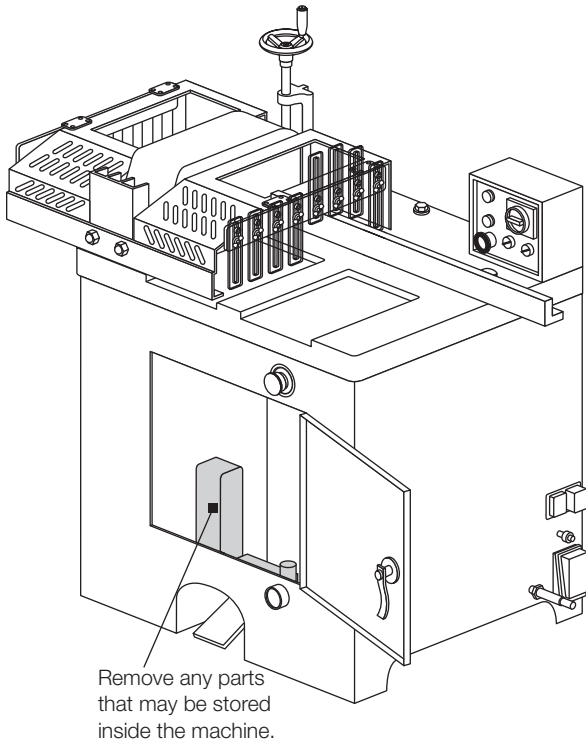

- Close and lock the front access door.

3.3 Inspection

Save all containers and packing materials until you are satisfied that your machine has arrived in good condition. If you discover the machine is damaged after you've signed for delivery, immediately call Stiles Customer Service at 616.698.7500.

When you are completely satisfied with the condition of your equipment, you should inventory its parts.

Open and check the contents of all containers to ensure all tools, hardware, and accessories are included. The tool kit should contain the following items:

- 19mm T-wrench
- 5mm Allen wrench
- Door key/handle
- Adjustment handle
- Leveling plates and bolts
- Dust port connection
- Acrylic fingers for infeed of safety guard
- Paint (2-color set)
- User manual

3.4 Move Machine to Final Position

Be sure the site is properly prepared. Refer to section 2.0 for details.

Be sure the front and side access doors are closed and locked before transporting.

TOOLS REQUIRED:

- Hand truck or fork lift

Use a hand truck or fork lift to move the machine on its pallet to its final location. If using a fork lift, make sure fork travel is clear of any obstacles.

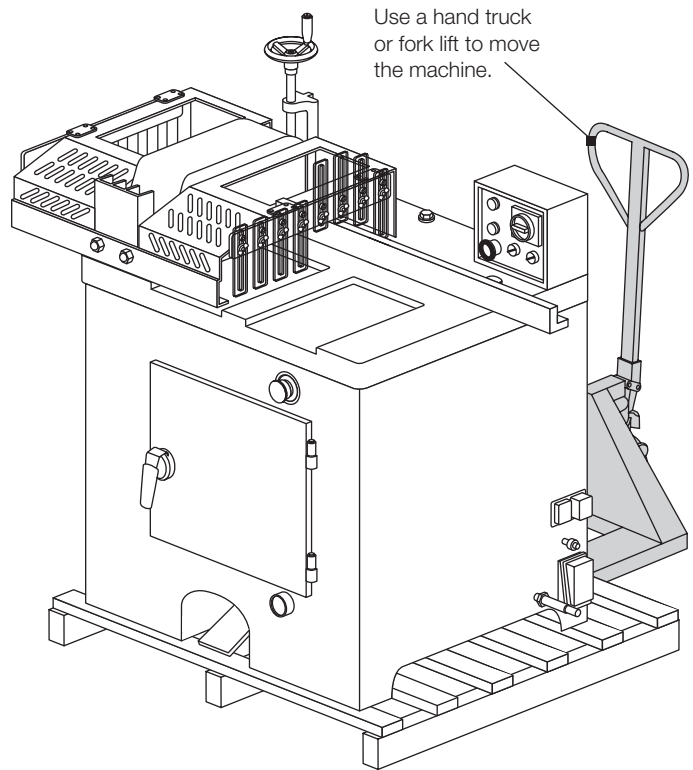

3.5 Remove Machine from Pallet

CAUTION

The CUT 14 weighs approximately 540 pounds. For this procedure, we recommend using four people.

TOOLS REQUIRED:

- Adjustable wrench
- Machine-door key

When the machine has been placed at its final location, carefully remove the machine from the pallet.

- From inside the cabinet, remove the bolts that secure the machine to the pallet at the interior corners.
- Lift the machine from the pallet by one of 2 methods:
 - Team lift
 - Slide machine onto forks of fork lift
- Carefully slide the machine into final position.

3.6 Level

TOOLS REQUIRED:

- Bubble Level
- Adjustable wrench

Use a bubble level along the length and width of the tabletop surface to check for level. Use an adjustable wrench to adjust leveling bolts to level the machine.

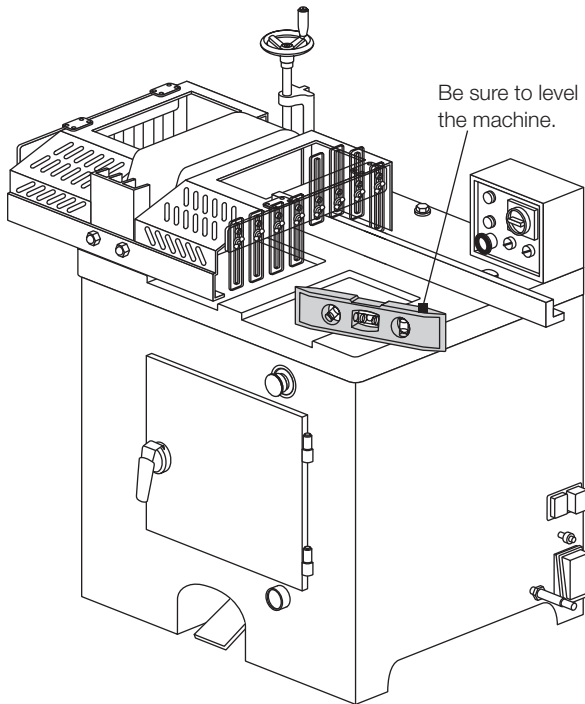

3.7 Pre-Operation Cleaning

⚠ WARNING

Use proper cleaning agents and methods described below. Do not use gasoline or other petroleum-based solvents. There is a risk of explosion and burning if these products are used. Serious personal injury may occur.

Machine Surfaces

After the machine is unpacked, remove the rust preventative oil that coats the machine. Use a soft cloth and nonflammable degreasing agent, such as Simple Green or other orange/citrus-based cleaner. Do not use abrasive pads.

Saw Blade Flanges

If blade is not pre-mounted, remove saw blade flanges and clean well to remove all rust-preventative oils. When cleaning, make sure no dust or debris is left on the saw blade flanges.

4.0 Assembly

To be assembled:

- Saw blade
- Dust exhaust outlet
- Safety guard assembly

4.1 Saw Blade

WARNING

Make sure the machine is disconnected from its power source before installing the saw blade.

CAUTION

The saw blade is extremely sharp. Wear gloves when installing the saw blade to prevent injury.

The CUT 14 requires an 14" diameter blade. Blade bore diameter is 1". Specific tooling requirements depend upon application. Please contact Stiles Machinery at 616.698.7500 for assistance with your tooling needs.

Use only saw blades with maximum safe operating speeds of 4,100 rpm or greater. The CUT 14 saw arbor runs at a fixed speed of 4,100 rpms.

Always keep the saw blade sharp for optimum cutting quality.

1. Before installing the saw blade, remove the rust-preventative oil that coats the surface.
2. Open the side access door by loosening the door safety bolt (long screw).

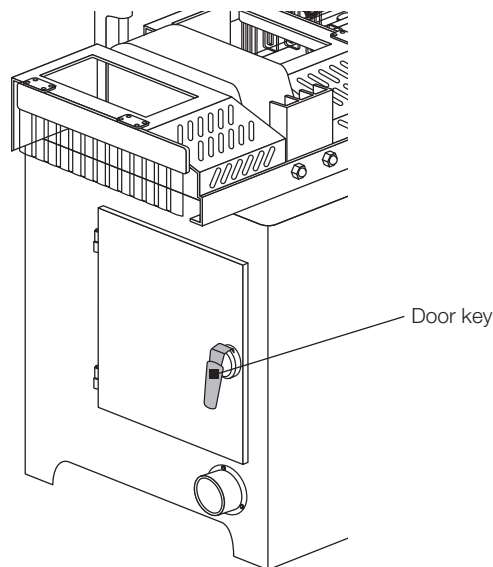

3. Ensure that the arbor and flange are clean and free of dust and debris.

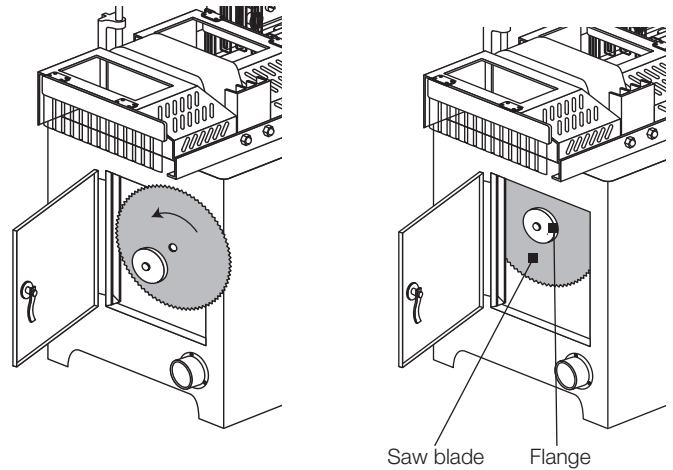

4. Attach the saw blade and flange onto the arbor.
5. Make certain the saw blade teeth point toward the blade's running direction.
6. Tighten the saw blade securely using the supplied T-wrench.
7. Close the saw blade access door and lock. Ensure the door safety locking bolt (long screw) is tightened.

4.2 Dust Exhaust Outlet

PARTS REQUIRED:

- Dust port connection

TOOLS REQUIRED:

- Allen wrench

The CUT 14 is equipped with a dust exhaust outlet, located on the left side of the machine.

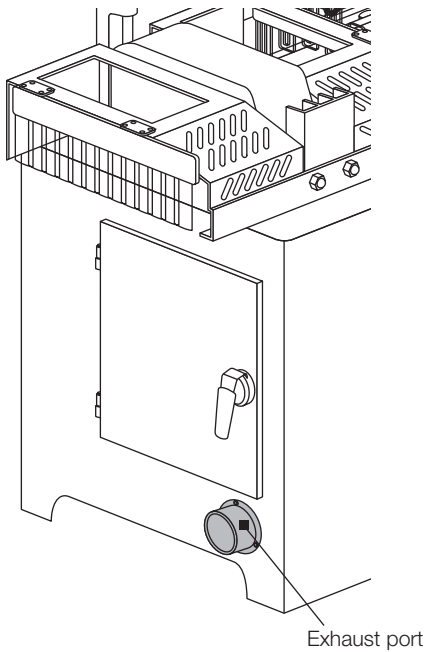

Attach the dust collection manifold to the machine frame with the three Allen bolts provided.

The dust exhaust outlet diameter is 4". Use a proper diameter of flexible hose to connect the exhaust outlet to an appropriately sized dust collector. Refer to section 1.5 for dust collection requirements.

4.3 Safety Guard Assembly

WARNING

Always use the safety guard assembly when using the CUT 14.

PARTS REQUIRED:

- Safety guard assembly

TOOLS REQUIRED:

- Adjustable wrench

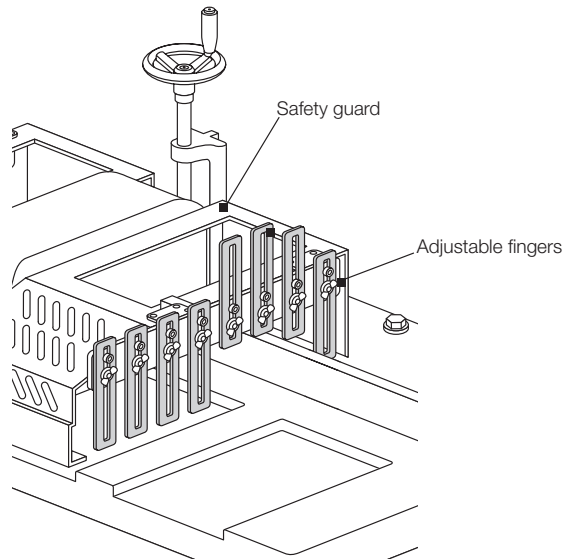

1. Attach the safety guard assembly body at the pilot hole locations using the hex nuts provided. There are four mounting points on the guard assembly body:
 - front of machine
 - inside-back on the table side of the guard assembly
 - outfeed side of the machine
2. Adjust the acrylic fingers on the safety guard to the height of your workpiece, leaving $\frac{1}{4}$ " – $\frac{3}{8}$ " clearance.

5.0 Connect to Power

- Voltage – Steady state voltage +/- 10% of nominal voltage.
- Machine needs steady voltage at all times.

WARNING

Before connecting power to the machine, make sure all screws and fasteners are tightened, all mechanical functions work freely, and the saw blade turns freely without touching the machine.

WARNING

All connections to electrical power should be completed by a licensed electrician.

Before connecting to a power source, confirm that the electrical current of the power source is the same as the electrical system supplied with your machine. Ensure the machine is protected with an external over current protective device per your local regulating authorities.

Machine must be properly grounded to prevent electric shock. Never connect the yellow/green wire to a live terminal.

Once connected to power source, terminals are electrified even while the power switch is off.

To connect source power to the machine:

1. Remove one screw (A) and remove terminal box cover (B).
2. Remove clear plastic insulator that covers the terminals (C).
3. Insert source power cables through opening of terminal box (D).
4. Connect the three power cables to terminals L1, L2 and L3, (E) and the yellow/green ground wire to ground terminal (F).
5. Replace the clear plastic insulator (C) and the power box cover (B).

Note: Before operating, the phasing will be tested to ensure sandblade is turning the correction direction. If not, L1 and L2 should be switched to change phasing.

WARNING

Always shut off power at source before removing terminal box cover. Failure to comply with this action may result in electric shock.

CAUTION

We have covered some basic electrical requirements for the safe installation of your machine. These requirements may not cover all installation requirements. You must confirm that your particular electrical configuration complies with all local codes. Ensure compliance by checking with your local municipality and a licensed electrician.

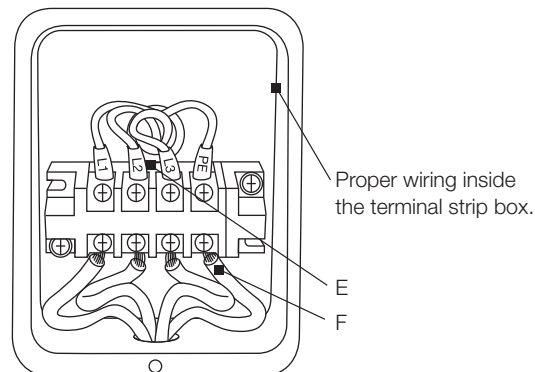
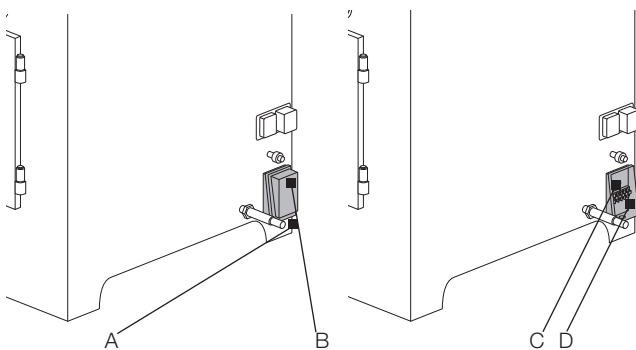

6.0 Safety

WARNING

Like all power equipment, there is danger associated with the Ironwood CUT 14. Use caution and follow all safety instructions. Take every precaution to protect yourself, others around you, and the machine itself from improper use. Safety is a combination of common sense, training, and being alert at all times while operating your machine. If instructions, warnings, and cautions are not followed, serious personal injury or death may occur.

EYE PROTECTION: Always wear approved safety glasses or a face shield when operating this machine. Only use eye protection that meets or exceeds the standards of the American National Standards Institute (ANSI).

EAR PROTECTION: Always wear ear protection during machine operation.

DRESS CODE: Do not wear loose clothing, neckties, jewelry, or gloves that can get caught in moving parts. Confine long hair and keep sleeves above the elbow.

ELECTRICAL GROUNDING: Your machine must be electrically grounded. If a cord and plug are used, make certain the machine is properly grounded. Follow the grounding procedure indicated by the National Electric Code and local regulating authorities.

GUARDS: Make certain that machine guards are in place and in good working order. The machine should never be operated without the safety guards in place.

TOOLING AND ACCESSORIES: Use only recommended tooling and accessories. Improper tooling and accessories may cause personal injury or damage to your machine. Regularly maintain your tools and accessories. The saw blade should be sharpened and cleaned for safe, optimal performance. Follow instructions for lubricating and changing tooling and accessories.

POWER: Make sure the starter is in the OFF position before connecting power to the machine.

Make certain the machine is either unplugged or electrically disconnected and locked out when performing all maintenance, cleaning, or machine adjustments. Never leave the machine running unattended. Always turn the power off and stay by the machine until the saw blade comes to a complete stop.

HOUSEKEEPING: Before turning the machine on, remove all extra items on or around the machine. Keep the work area clean and free of scrap material, sawdust, and other debris to minimize the danger of slipping. Use compressed air or a brush to remove chips or debris. NEVER use your hands.

7.0 Operation and Adjustments

7.1 Control Panel

The control panel on the front of the machine handles all machine control functions and has the following features:

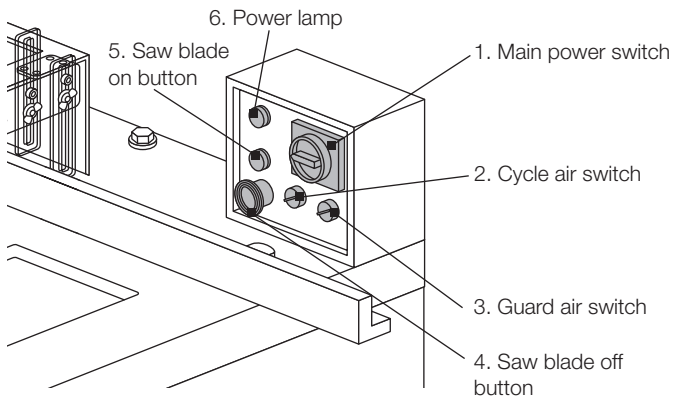

1. Main Power switch:

- Turn the switch to the ON position to turn on the power to the machine.
- Turn the switch to the OFF position to turn off the power to the machine.

2. Cycle Air Switch

- Turn the switch to the ON position to activate the air supply to the foot pedal or push button controls. The saw carriage stays in the down position until the foot pedal or push button controls are triggered.
- Turn the switch to the OFF position to de-activate the air supply to the foot pedal or push button controls.

3. Guard Air Switch

- Turn the switch to the ON position to activate the air to the blade guard / hold-down clamp. When the guard air switch is turned on, the hold-down clamp rises to the set position. The saw carriage stays in the down position.
- Turn the switch to the OFF position to de-activate the air to the blade guard / hold-down clamp. The hold-down clamp drops when air is turned off.

4. Saw Blade Off

- Stops the saw blade motor. After approximately 30 seconds, the saw blade stops rotating. The access door can be opened 60 seconds after the saw blade is turned off.

5. Saw Blade On

- Starts the saw blade motor.

6. Power Lamp

- Illuminates when the power switch is in the ON position.

7.2 Emergency Stop

⚠ CAUTION

There is an emergency stop switch for the air and electrical system. When the switch is pressed, the hold-down clamp raises immediately to release the work piece and the power will be cut to the motor.

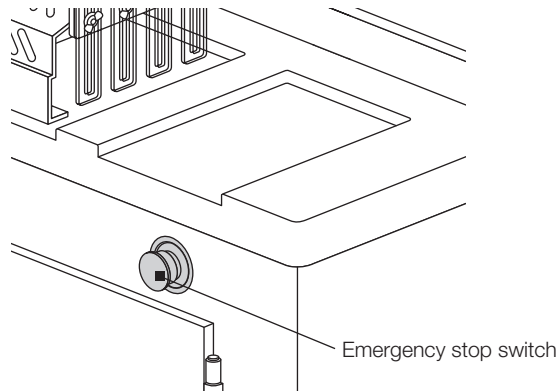

7.3 Pneumatic Control

Machine operation is controlled by either a foot pedal at the bottom of the machine front, or dual push buttons on the front of the machine, depending on machine configuration.

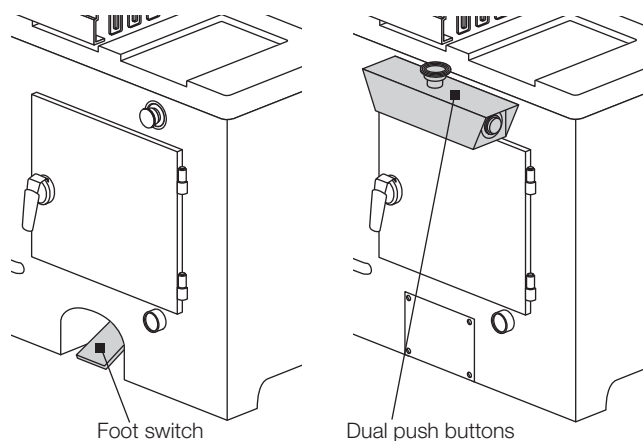

When you press the foot pedal or dual push buttons one time and release, the following occurs:

1. The hold-down clamp lowers to hold the workpiece securely.
2. The saw blade rises to cut the workpiece.
3. After the cut, the saw blade lowers under the table.
4. The hold-down clamp rises to release the workpiece.

Note: If you press the foot pedal or push buttons continuously for one minute, the saw blade will remain in the up position after the cut. To correct, press the Emergency Stop switch to lower the saw blade.

Do not activate the pneumatic control unless the saw blade is on and is operating at full rotational speed.

7.4 Adjust Hold-Down Clamp

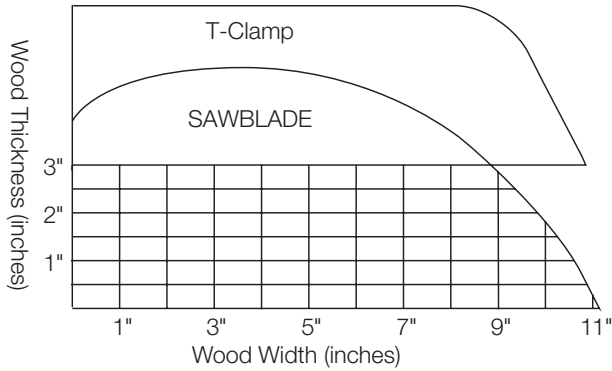

Adjust the position of the hold-down clamp, leaving $\frac{1}{4}$ " – $\frac{3}{8}$ " between the clamp and the workpiece.

1. Raise the hold-down clamp by turning the Guard Air switch to the right, or ON position.
2. Place workpiece to be cut under the hold-down clamp.
3. Turn the height-adjustment handle to raise or lower the hold-down clamp. If you feel resistance while turning the handle, turn the Guard Air switch to the left, or OFF position, until the handle turns easily.
4. Tighten the lock nut to set the height.

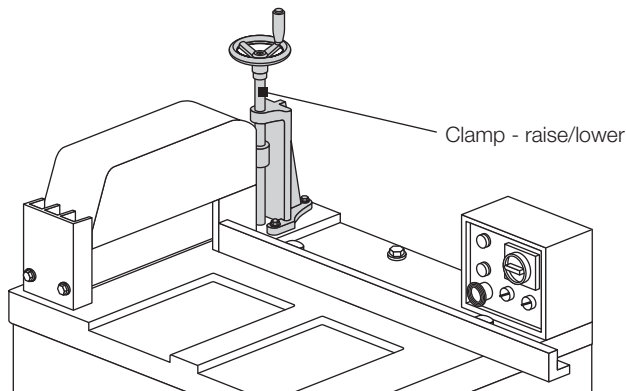

7.5 Adjust Air Pressure

CAUTION

Do not operate the machine if air pressure does not reach the normal working pressure of 75 psi.

The CUT 14 requires a normal working pressure of 75 psi (5 bar) with an air volume of 12 cfm for safe machine operation.

The main air connection point is located on the bottom-right side of the machine for CUT 14L, and bottom-left side for CUT 14R. The working pressure is indicated on the pressure gauge of the air regulator mounted inside the machine, behind the front access door, on the same side of the machine as the main air connection point.

To adjust working pressure, lift the pressure adjustment knob and turn clockwise to increase pressure, or counterclockwise to reduce pressure. Push back down to lock the adjustment knob and to maintain the working pressure at 75 psi.

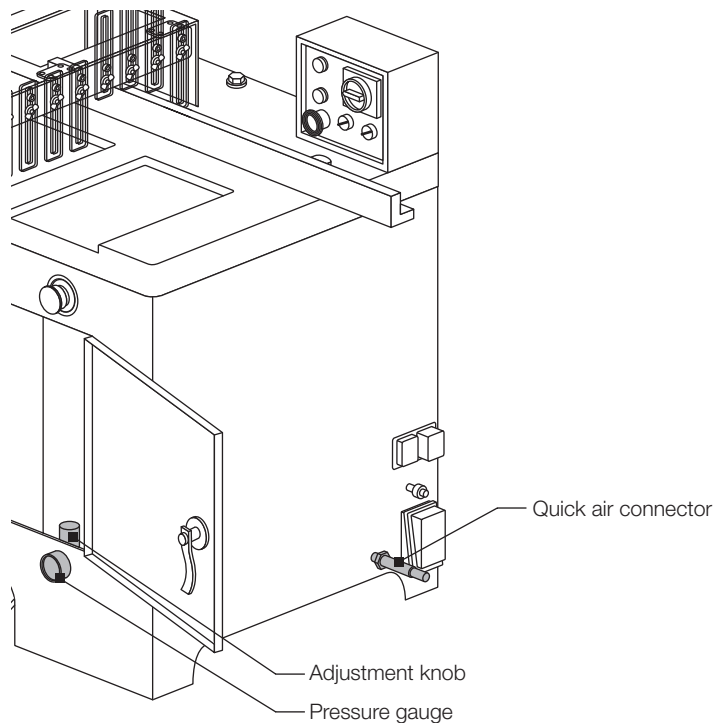

7.6 Adjust Fence Squareness to Saw Blade

The fence should be positioned at a 90-degree angle to the saw blade. This ensures that the workpiece is cut squarely. To adjust the fence:

1. Disconnect the machine from its power source.
2. Turn Guard Air switch to the ON position.
3. Turn the Cycle Air switch to the OFF position.
4. Place a wood block under the edge of the hold-down clamp to keep the clamp up, off of the table. To avoid machine damage, the wood block position should not interfere with or overlap the saw blade path / outline as it rises.

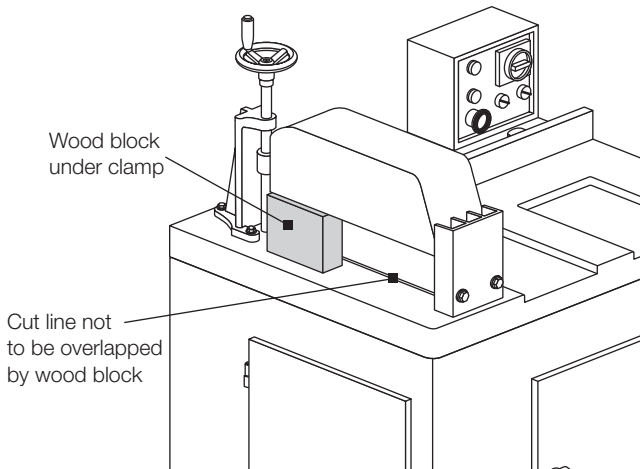

10. Adjust the fence until it is square to the saw blade.
11. Tighten the two lock screws located on the back side of the back fence.
12. Turn the Cycle Air switch to the ON position to lower the saw blade.

For a quick squareness adjustment: The table is marked with a reference line that is square to the saw blade. Align the fence with this line.

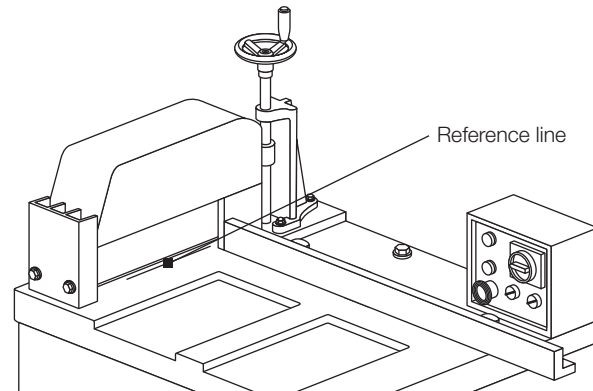

5. Turn the Cycle Air switch to the ON position.
6. Press the foot pedal or dual hand controls simultaneously to raise the saw blade.
7. Turn the Cycle Air switch to the OFF position to set the saw blade at the raised position.
8. Use a combination square to check squareness between the fence and the saw blade. Do not allow the combination square to touch the blade teeth.
9. If the fence is not square to the saw blade, loosen the two lock screws located on the back side of the back fence.

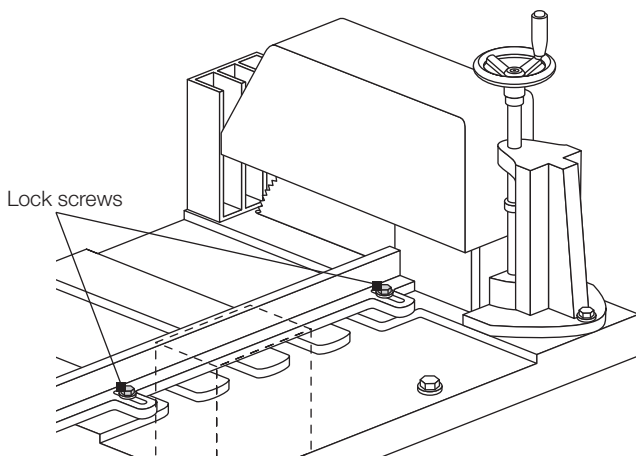

7.7 Cutting the Workpiece

⚠ WARNING

Do not attempt to operate machine if you are not completely familiar with its operation. Obtain immediate advice from a supervisor, instructor, or other qualified personnel.

Use of this machine requires that you give your work your undivided attention, and careless acts or not paying close attention to work being performed may result in serious injury to yourself and/or others. Never operate this or any machine under the influence of drugs, alcohol, or any medication that may impair judgment.

Do not cut badly warped wood. The workpiece must sit flat on the table without rocking.

Dust created by manufacturing activities may be harmful to your health.

Your risks from exposure may vary. Always work in a well-ventilated area and wear safety approved, protective dust masks specifically designed to filter out microscopic particles. Utilize wood dust collection systems appropriate to your machine type.

Stand to the right of the workpiece when feeding it through the saw to avoid potential injury from kickback and loose chips.

To cut a workpiece, perform the following steps:

Step 1: Turn on power to the machine.

Step 2: Make sure the dust collector is operating. If it is not, turn on dust collector. Note: when operating the CUT 14 for the first time, ensure the saw blade is turning in the correct direction and that the blade is mounted correctly. If not, please change the phasing of the machine so the saw blade turns in the correct direction. Refer to 5.0.

Step 3: Press Saw Blade ON.

Step 4: Turn on the Guard Air and the Cycle Air.

Step 5: Feed the workpiece through the machine. Always use the fence to position and guide the workpiece. When cutting a long workpiece, use an infeed and outfeed conveyor table for support.

Step 6: Press the pneumatic control foot pedal or dual push buttons one time.

Step 7: Wait for the saw to complete the cutting cycle and remove the workpiece.

⚠ WARNING

Never remove the cut-off piece until the cutting cycle is complete.

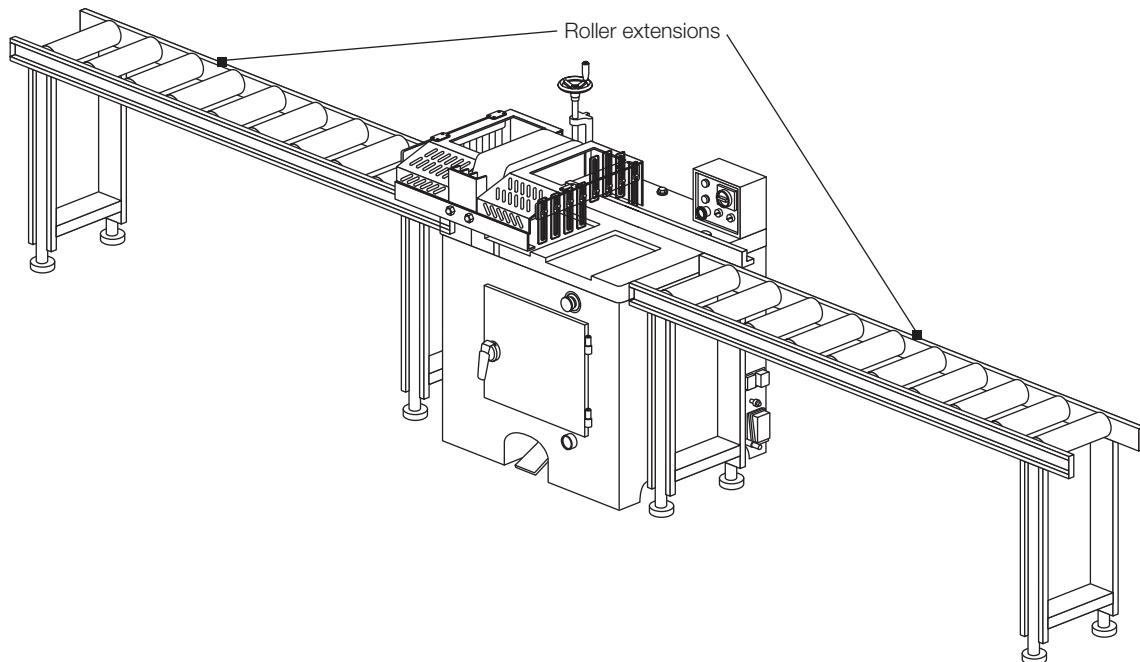

8.0 Maintenance

⚠ WARNING

Before performing any type of maintenance or adjustments, make certain that the machine is disconnected from its power source and completely shut off.

⚠ WARNING

Never operate the machine until it has been properly lubricated and all necessary maintenance work has been completed.

NOTE: After changing a setting, making an adjustment, performing repair/maintenance work, or troubleshooting, please check that all applicable safety functions are working properly before performing another operation.

8.1 Cleaning

Clean and remove sawdust and debris on the machine every day and in between jobs to maintain accurate cutting.

8.2 Lubrication

Every month, check the lubrication level in the lubrication bowl of the air regulator unit. If necessary, fill the bowl up to 80% of capacity to ensure that the air cylinder is properly lubricated. Before adding oil, turn the guard air switch and the cycle air switch to the off position. Use No. 32 light oil for the lubrication bowl.

Every week, check for accumulated water in the filter bowl of the air regulator unit. To release water, turn the Guard Air switch to the off position.

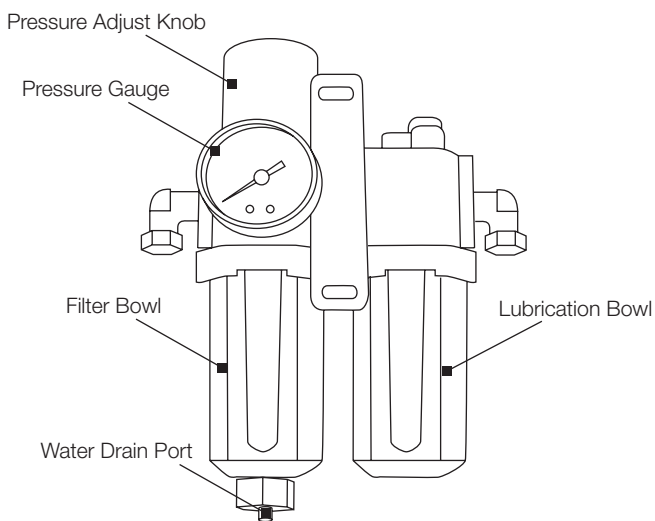

8.3 Change the Saw Blade

⚠ CAUTION

The saw blade is extremely sharp. Wear gloves during saw blade replacement.

1. Disconnect the machine from its power and air source.
2. Open the side access door using the supplied door handle.

Note: Loosen the door safety locking bolt (long screw) after the saw blade has been turned off to allow the saw blade to come to a complete stop.

3. Remove the saw blade lock screw and flange.
4. Remove the saw blade.

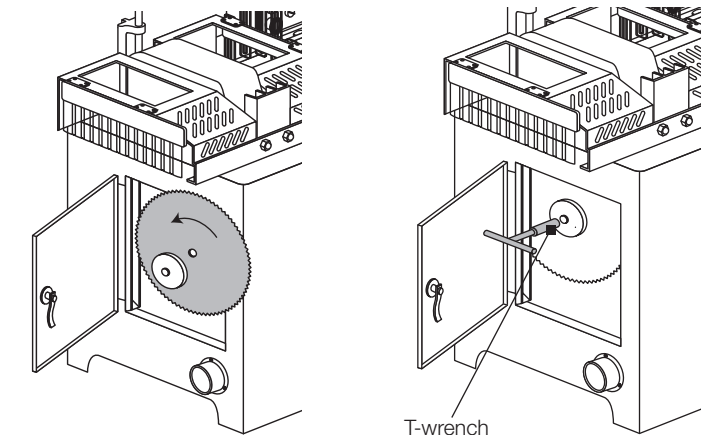
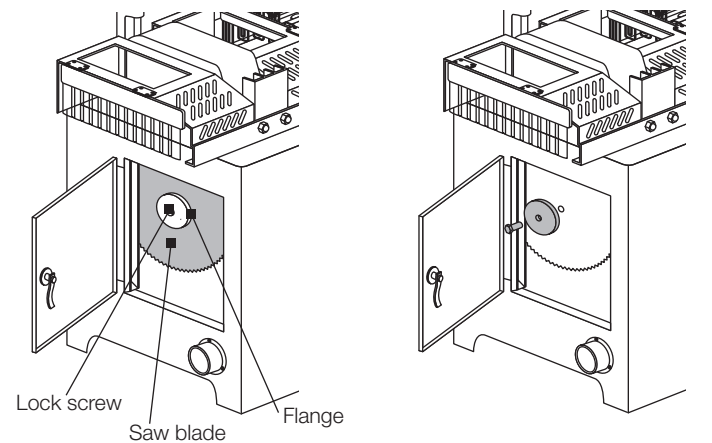

5. Attach the new saw blade and flange onto the arbor. Ensure that the arbor and flange are clean and free of dust and debris before fitting on the saw blade.
6. Make certain the saw blade teeth point toward its running direction.
7. Tighten the saw blade securely using the supplied T-wrench.
8. Ensure the blade access door is completely closed and locked and the door safety locking bolt (long screw) is tightened.

8.4 Adjust V-Belt Tension

Over time, V-belt tension may gradually loosen. To adjust belt tension:

1. Disconnect the machine from its power source.
2. Slightly loosen the 4 lock screws on the machine table.

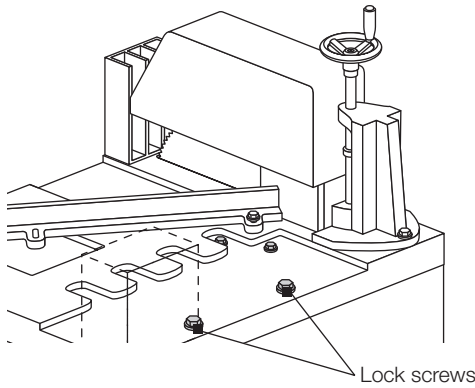

3. Open the front access door, using the supplied door handle.
4. Move the motor away from the arbor, towards the back of the machine, until the belts are taut.

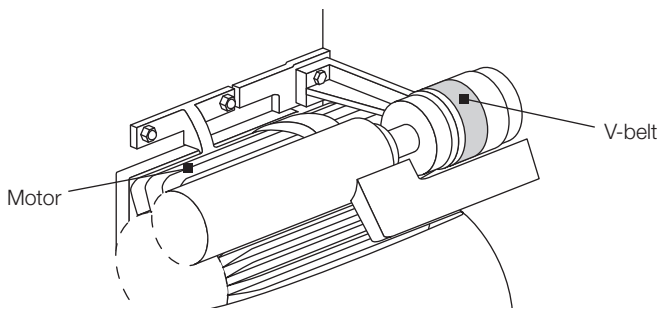

5. After V-belt tension is adjusted, tighten the 4 lock screws on the table to secure the motor in place.

Note: Ensure motor pulley and arbor pulley are square to prevent vibration.

6. If the back fence position was moved to access the top motor bolts, re-square the back fence to the saw blade.

Note: After belts have stretched and are re-tensioned, belt life span will be diminished. Do not replace 1 belt at a time. All 3 should be changed together to maintain equal pressure.

8.5 Replace V-Belts

Replace V-belts if the saw arbor speed decreases or makes an abnormal sound when starting the saw blade. Replace all three belts at the same time to ensure a consistent tension on each belt.

To replace V-belts:

1. Disconnect the machine from its power source.
2. Slightly loosen the 4 lock screws on the machine table.
3. Open the front access door, using the supplied door handle.
4. Move the motor towards the arbor until the belts can be mounted on the pulleys.
5. Once belts are mounted, adjust belt tension (see section 8.4, steps 4-6).

The V-belt specification is MF-1300. Stiles Part Number: 73-145-50000.

Note: It is recommended to change all 3 belts at the same time to avoid affecting accuracy of the parallel between the motor pulley and the spindle pulley. If they are not parallel, belts will wear very quickly.

9.0 Troubleshooting

Trouble	Possible Cause	Solution
Saw blade will not start up	<ol style="list-style-type: none"> 1. Power supply is abnormal. 2. Power wire is damaged. 3. Overload tripped. 4. Arbor spindle is locked up. 5. Motor not functioning. 	<ol style="list-style-type: none"> 1. Check with a volt meter. 2. Inspect wiring for damage. 3. Reset overload. 4. Replace arbor spindle. 5. Replace or repair motor.
Poor cutting quality	<ol style="list-style-type: none"> 1. Saw blade is dull. 2. Inaccurate fence alignment. 3. Improper wood moisture content. 	<ol style="list-style-type: none"> 1. Sharpen saw blade. 2. Adjust fence squareness. 3. Humidify plant or maintain proper wood moisture content.
Burn marks on work piece	<ol style="list-style-type: none"> 1. Saw blade is dull. 2. Blade teeth are worn out or broken. 3. Power phasing is backwards. 	<ol style="list-style-type: none"> 1. Sharpen saw blade. 2. Replace saw blade. 3. Re-phase incoming power.
Saw blade slows down during cutting	<ol style="list-style-type: none"> 1. Saw blade is dull. 2. V-belt tension is too loose. 3. Blade teeth are worn out or broken. 	<ol style="list-style-type: none"> 1. Sharpen saw blade. 2. Adjust V-belt tension. 3. Replace saw blade.
Motor does not run at full speed	<ol style="list-style-type: none"> 1. Power voltage is too low. 2. Overloaded tripped. 	<ol style="list-style-type: none"> 1. Test voltage with volt meter. 2. Reduce load.
Motor is overheating	<ol style="list-style-type: none"> 1. Motor is dirty. 2. Motor is damaged. 3. Arbor is locked up or damaged. 	<ol style="list-style-type: none"> 1. Clean motor. 2. Check and repair motor. 3. Check arbor spindle for free rotation.

If you cannot resolve your issue, contact Stiles technical support at 616.698.6615.

9.1 Air Circuit Diagram With Foot Pedal Control

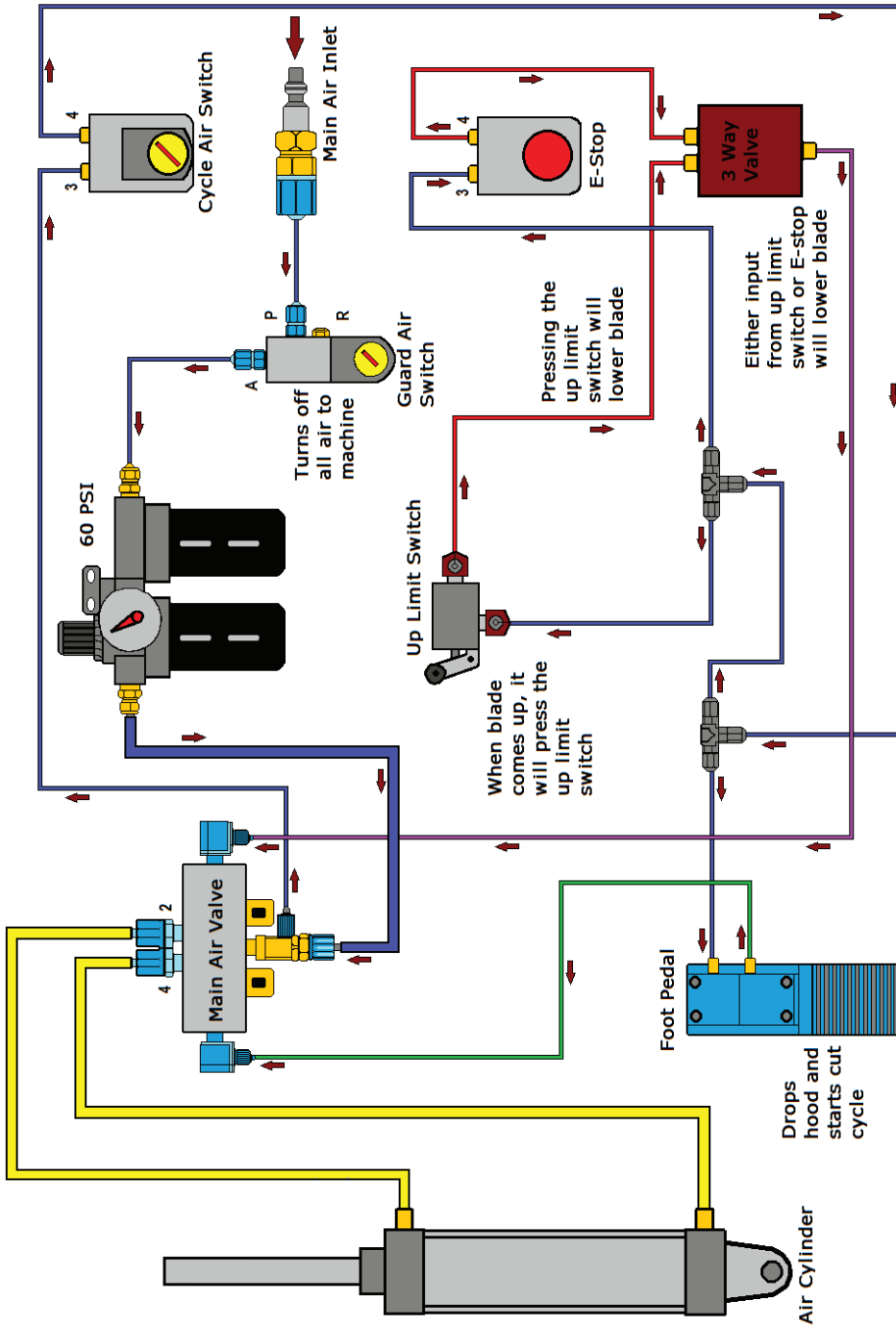

9.1 Air Circuit Diagram With Dual Push Button Controls

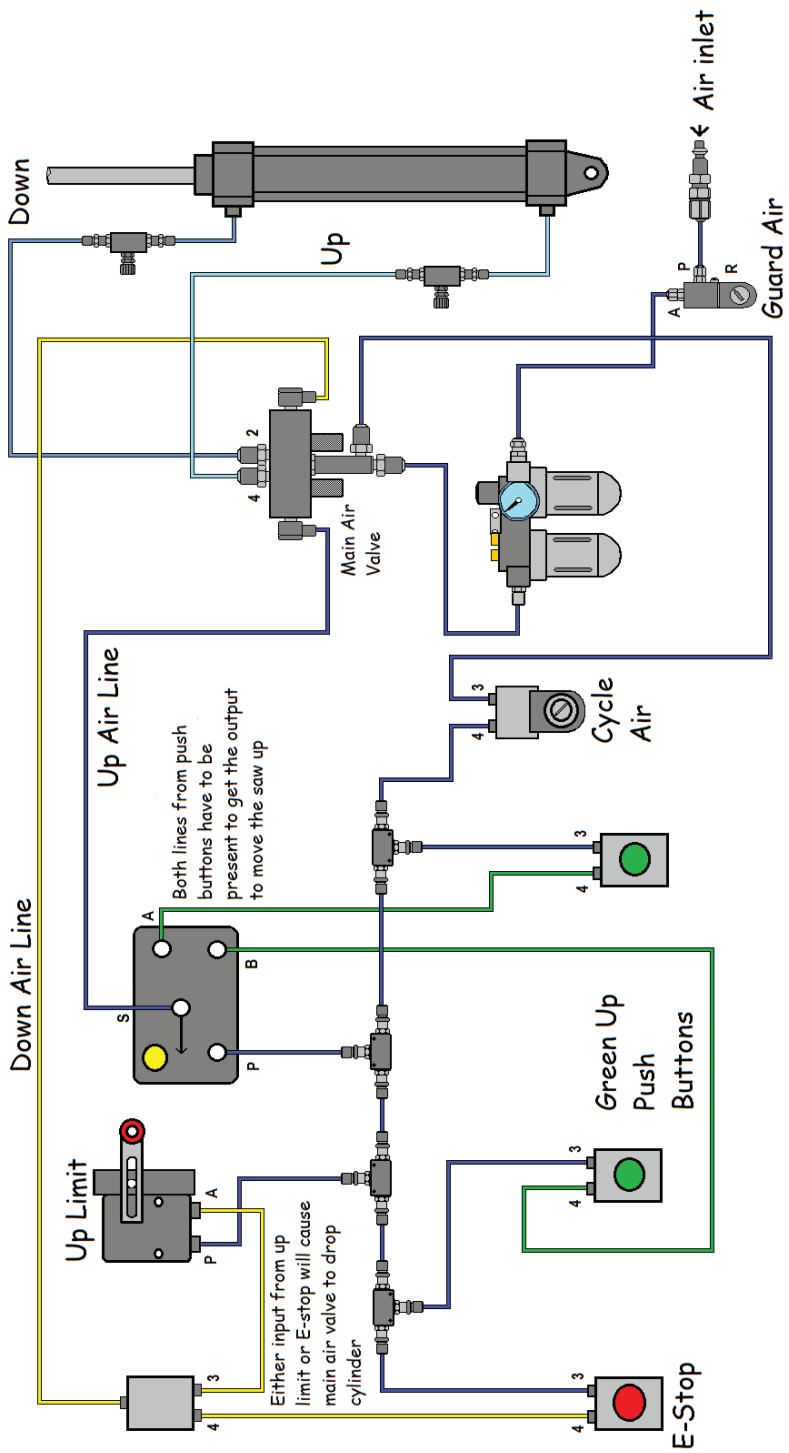

9.2 Electrical Diagram

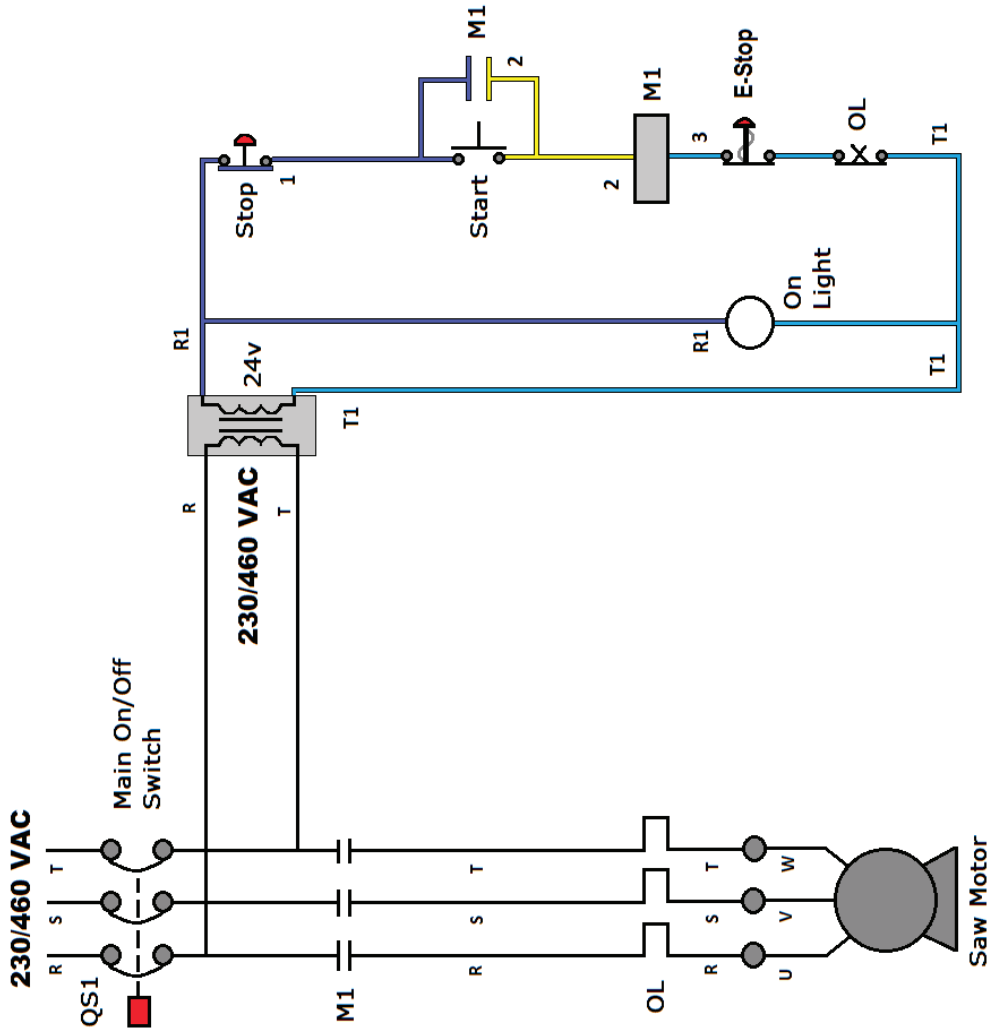

CUT 14R

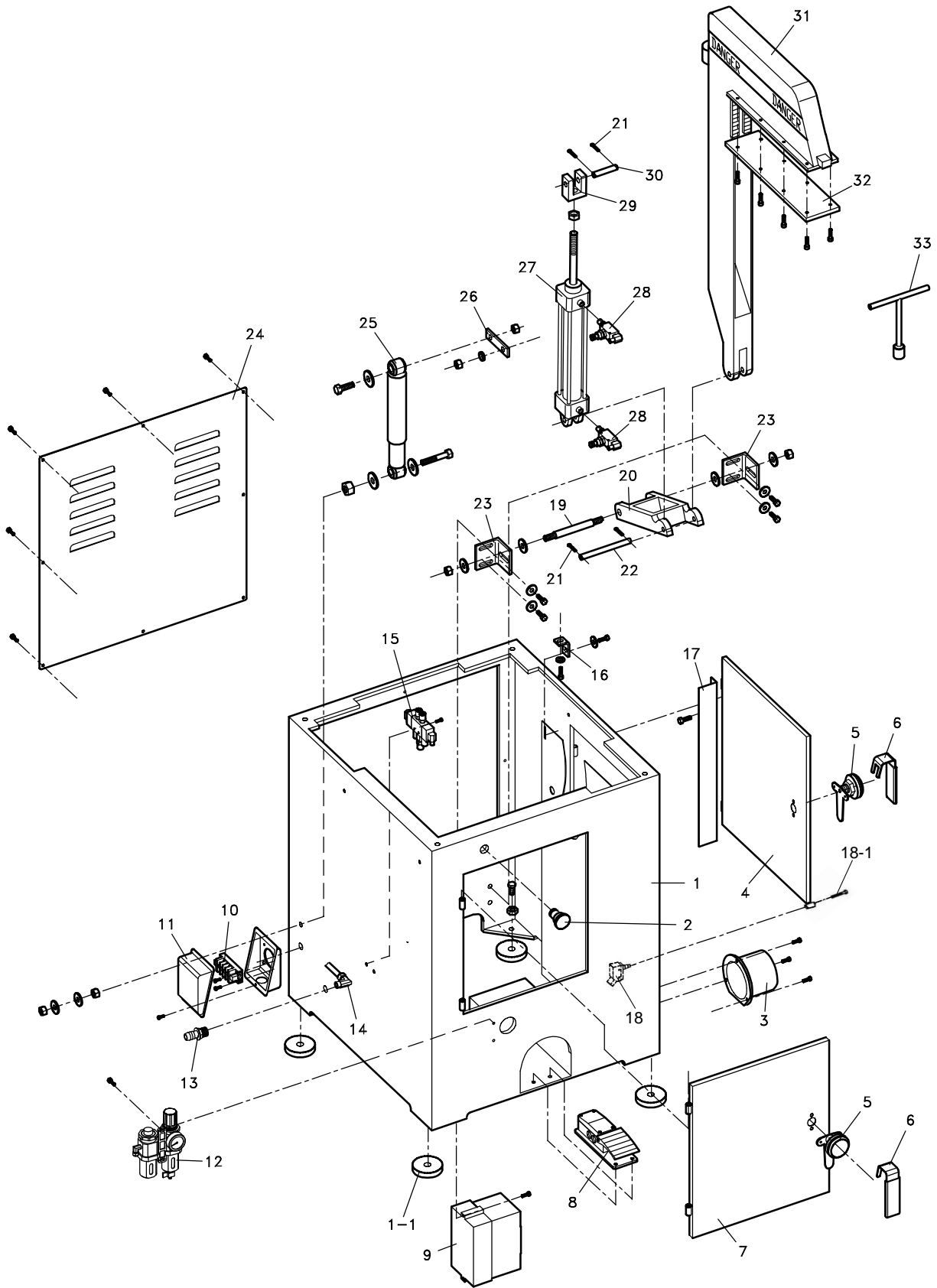

PART LIST

CUT14R					
REF	DESCRIPTION	Q'TY	REF	DESCRIPTION	Q'TY
14R-01	Cabinet	1	14R-18	Limit Switch (for sawbalde door)	1
14R-01-1	Circular Plate	4	14R-18-1	Long Screw	1
14R-02	Emergency Stop	1	14R-19	Stud Bolt	1
14R-03	Dust Port	1	14R-20	Support Frame	1
14R-04	Side Door	1	14R-21	Split Pin	4
14R-05	Door Lock	2	14R-22	Coupling Pin	1
14R-06	Lock Handle	2	14R-23	Support Angle Steel	2
14R-07	Front Door	1	14R-24	Back Door	1
14R-08	Pedal	1	14R-25	Cushion	1
14R-09	Magnetic Switch	1	14R-26	Connecting Link	1
14R-10	Wire Connecting Plate	1	14R-27	Air Cylinder	1
14R-11	Electrical Box	1	14R-28	Pressure Regulating Valve	2
14R-12	Air filter- Pressure regulator – Oil feeder	1	14R-29	Toggle	1
14R-13	Quick Air Connector	1	14R-30	Coupling Pin 1/2" x2"	1
14R-14	Air Copper Fitting	1	14R-31	T-clamp	1
14R-15	Air Valve	1	14R-32	Gasket	1
14R-16	Bracket	1	14R-33	Socket Wrench 19mm	1
14R-17	L Iron Plate	1			

CUT 14R

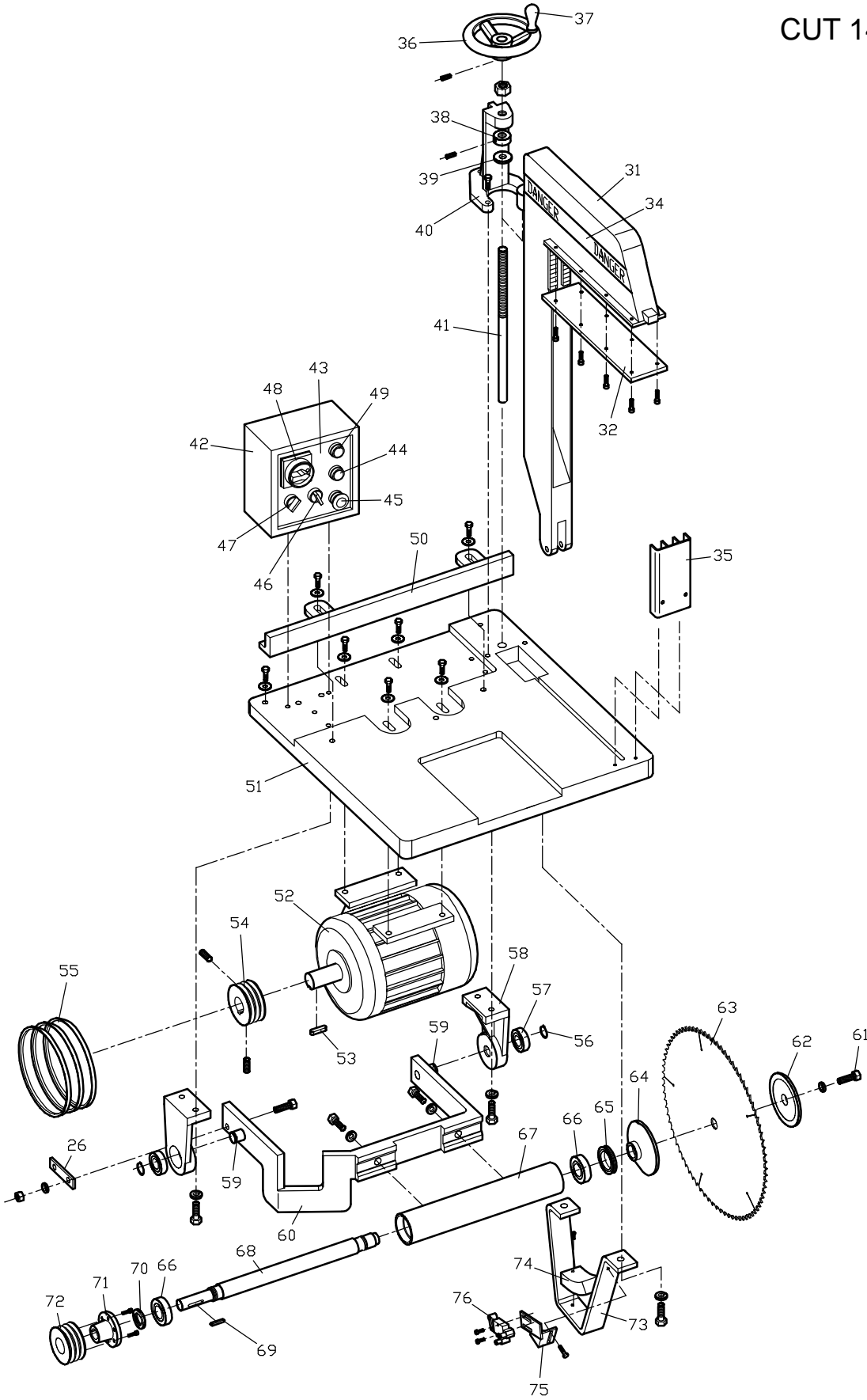

PART LIST

CUT14R					
REF	DESCRIPTION	Q'TY	REF	DESCRIPTION	Q'TY
14R-34	Danger Label	2	14R-56	C-ring	2
14R-35	Safety Guard	1	14R-57	Bearing 6205zz	2
14R-36	Adjusting Hand Wheel	1	14R-58	Bracket	2
14R-37	Drop Handle	1	14R-59	Shaft	2
14R-38	Lock Nut	1	14R-60	Suspension Bracket	1
14R-39	Rubber Ring	1	14R-61	SawBlade Screw	1
14R-40	Adjustable Seat	1	14R-62	Flange Washer	1
14R-41	Guide Screw	1	14R-63	Saw Blade	1
14R-42	Switch Box	1	14R-64	Inside Flange	1
14R-43	Switch Panel	1	14R-65	Locknut	1
14R-44	On Button	1	14R-66	Bearing 6206zz	2
14R-45	Off Button	1	14R-67	Quill	1
14R-46	Cycle Air Switch	1	14R-68	Main Spindle	1
14R-47	Guard Air Switch	1	14R-69	Key	1
14R-48	Power Switch	1	14R-70	Locknut-left	1
14R-49	Power Light	1	14R-71	Tapper Flange	1
14R-50	Fence	1	14R-72	Drive Pulley	1
14R-51	Table	1	14R-73	Lower Bracket	1
14R-52	Motor	1	14R-74	Lower Damper	1
14R-53	Key	1	14R-75	Limit Switch Bracket	1
14R-54	Motor Pulley	1	14R-76	Limit Switch	1
14R-55	V-belt MF1300	3			

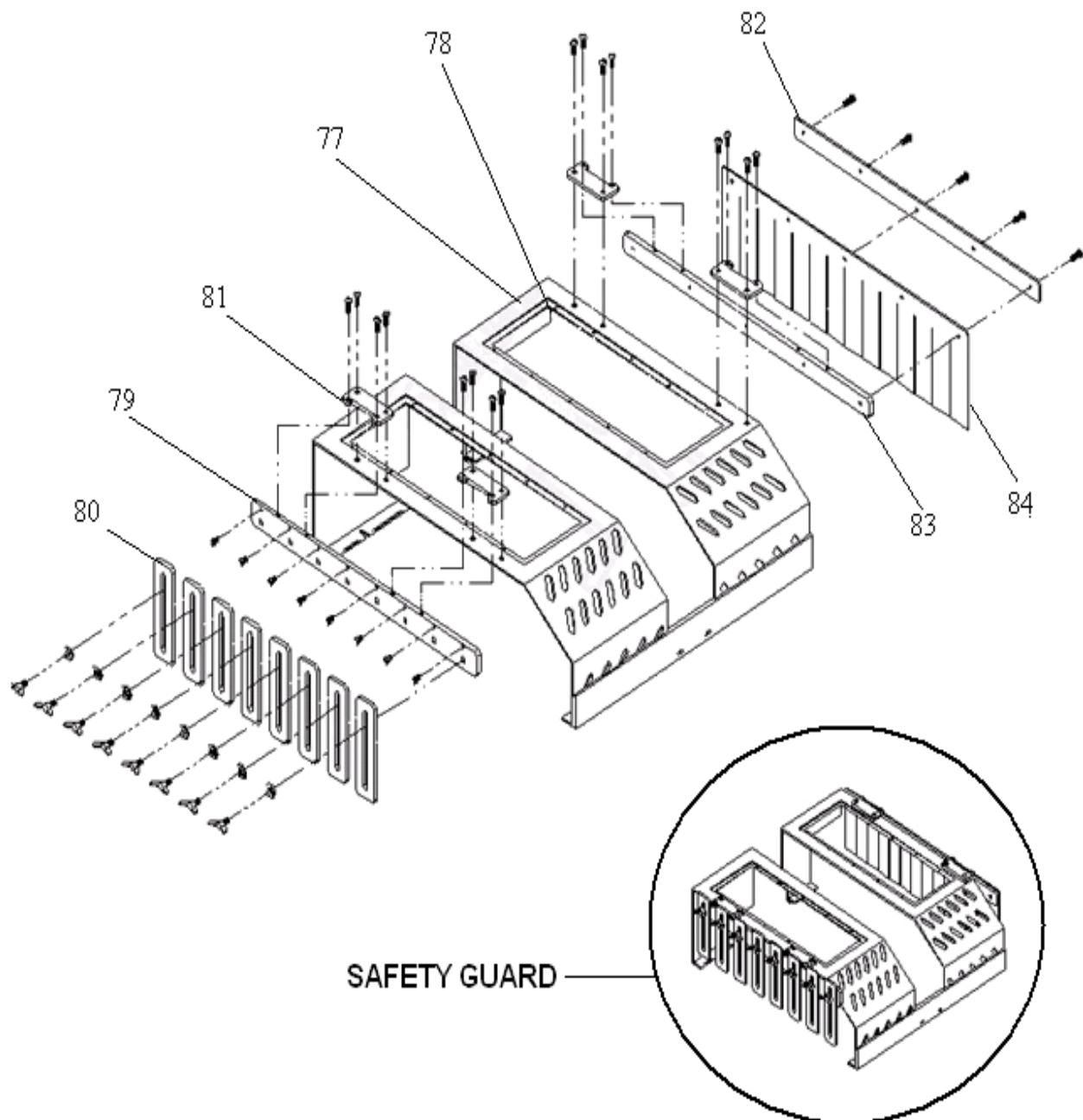

SAFETY GUARD		
REF	DESCRIPTION	Q'TY
14R-77	GUARD	1
14R-78	ACRYLIC PLATE	2
14R-79	FIXING PALLET (INFEED)	1
14R-80	SAFETY PLATE	8
14R-81	BRACKET	4
14R-82	FIXING PALLET (OUTSIDE)	1
14R-83	FIXING PALLET (INSIDE)	1
14R-84	PLASTIC STRIP	1

IRONWOOD

Version A
September 2013

© 2013 Stiles Machinery Inc.

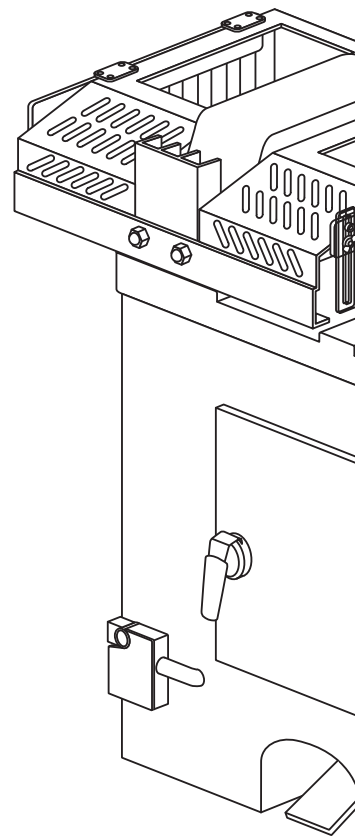

stiles

Stiles Machinery Inc.
3965 44th St. SE
Grand Rapids, MI 49512
p. 616.698.7500
f. 616.698.9411

www.stilesmachinery.com