

ADVENTURER 3 V2

Quick Start Guide

⚠ WARNING

-
1. Do not remove the wrapping around the nozzle.
 2. Hot! Avoid touching the heating nozzle in operation.
 3. Moving parts in printer may cause injury. Do not wear gloves or other sources of entanglement in operation.
-

Unpacking



1. Open the box.



2. Remove wrapping paper box on the top, there is a Quick start, an after-sales service, an accessory kit, a power cable and a roll of material on the plastic box.



3. Take out the printer of the carton, remove bubble pack outside the printer.



4. Tear off fixed tapes and front door protective bag.



5. Take power cable out and plug it into power input.

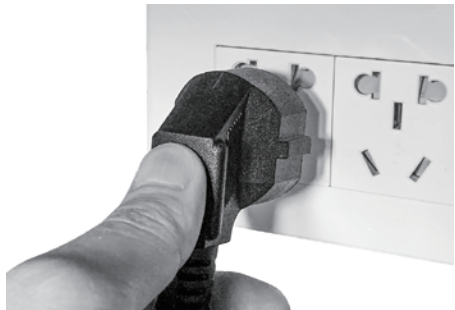

6. Plug the other end of the power cable into socket, turn on the power switch.



7. Turn on the power switch.



8. Open the front door.

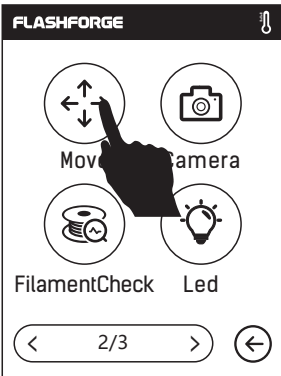
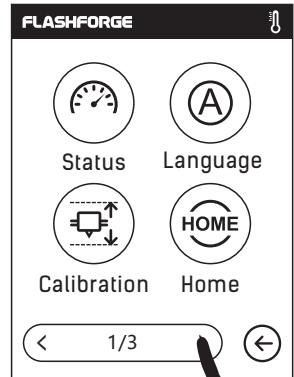
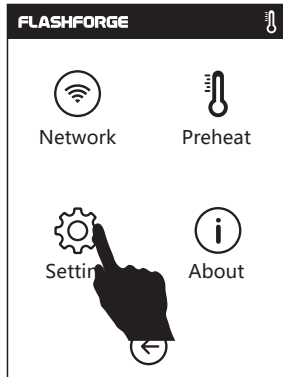
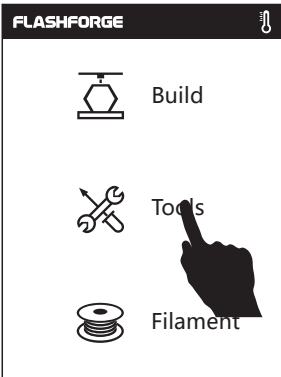

9. Tap [Tools]-[Setting] on the touch screen as the picture showed above, tap [Move].

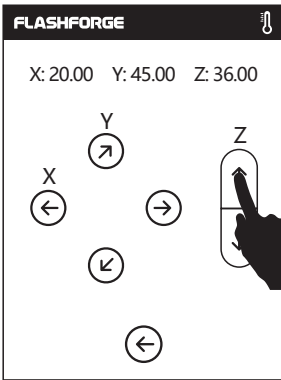

10. Tap the upper arrow in the moving page to make the extruder raises for removing the paper box on the bottom easier.



11. Squeeze wrapping paper box to the middle slightly and take it out.



12. Unboxing completed! Recommended that you take good care of packing materials for further carrying and keeping.

Kit Contents

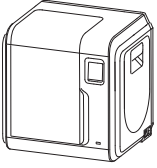

3D Printer



Filament



Power Cable



Flexible Build Plate



0.3mm 240°C Nozzle



**0.4mm 265°C
High Temperature
Nozzle**



Quick Start Guide



Screwdriver

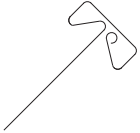

Unclogging Pin Tool



Allen Wrench

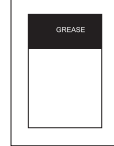

Grease

Getting to know your Adventurer 3 V2

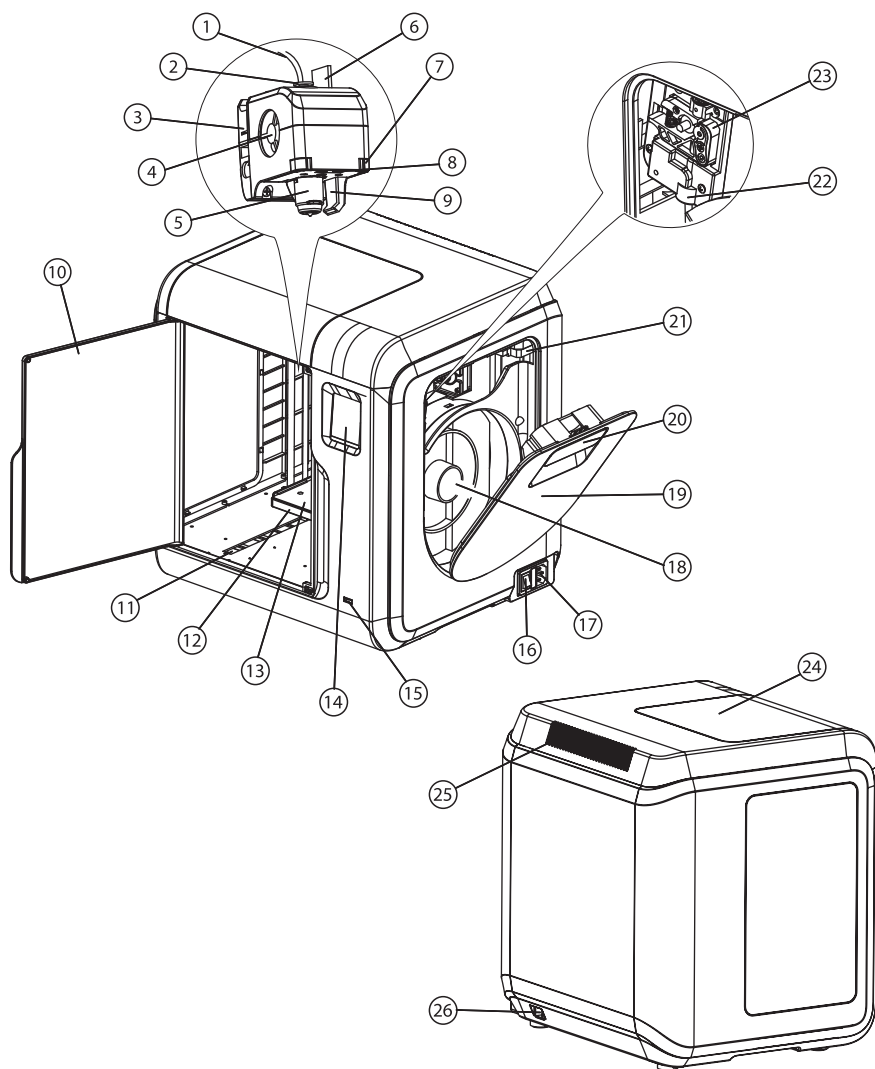

1. Filament guide tube 2. Filament guide tube joint 3. Extruder base
 4. Cooling Fan 5. Removable nozzle 6. Extruder cables 7. Clip 8. Led light
 9. Turbo Fan Baffle 10. Front door 11. Y-Axis sliding slot 12. Platform base
 13. Removable build plate 14. Touch-screen 15. USB stick input 16. Power switch
 17. Power input 18. Spool holder 19. Filament cover 20. Filament cover handle
 21. Moto 22. Filament intake 23. Filament feeding wheel 24. Top cover
 25. Air outlet 26. Ethernet input

First Print

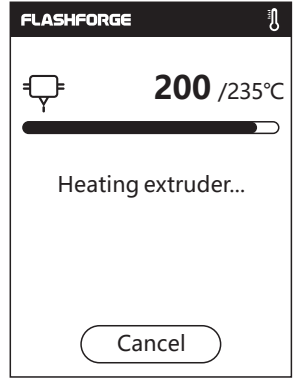
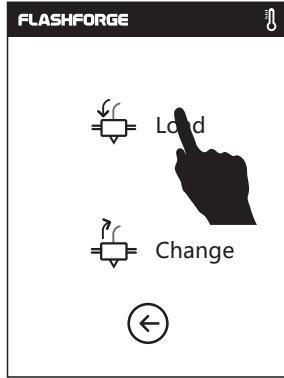
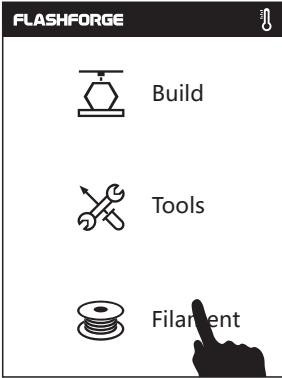

1. Tap [Filament], tap [Load], after load completed, tap [OK].

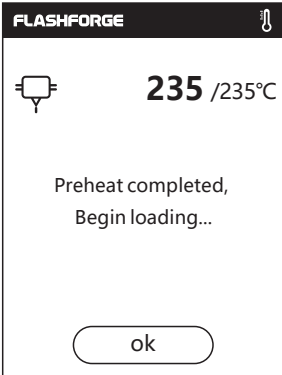

2. As shown on the left, loading starts when the extruder heated to target temperature.

3. Open the filament cover, insert the filament into the filament intake, push filament into the feeding wheel until some resistance is sensed.

Note: Please make sure filament has been pushed into the feeding wheel!

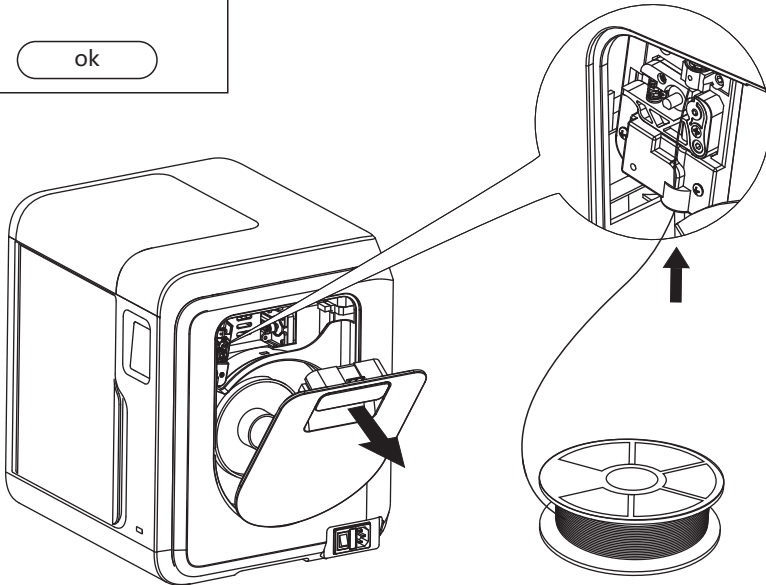

Mind the loading direction of filament, make sure to be clockwise as the picture showed.

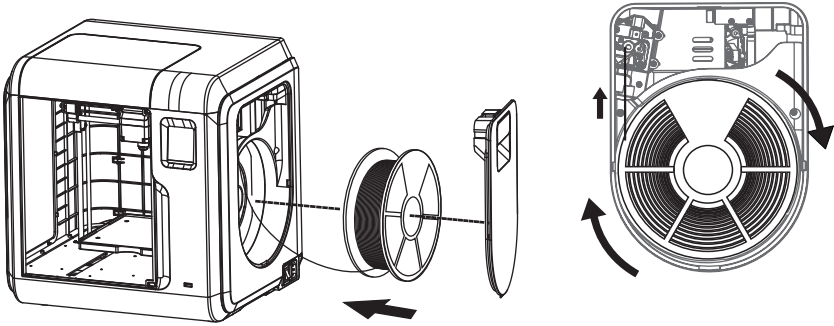

4. Load completed when you see filament come out of extruder, tap [OK]. Put the spool of filament on the spool holder, close the filament cover.

Model Print

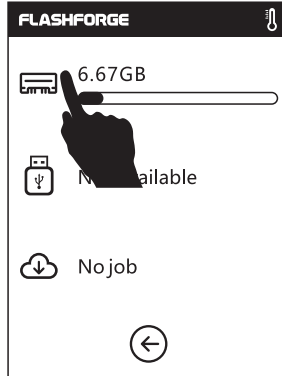
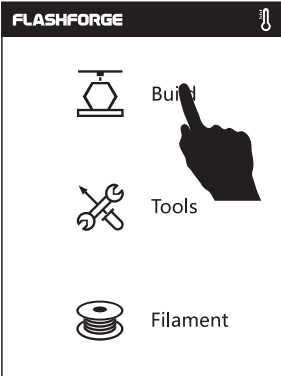

1. Tap [Build], choose the file path: Print from local memory card. 

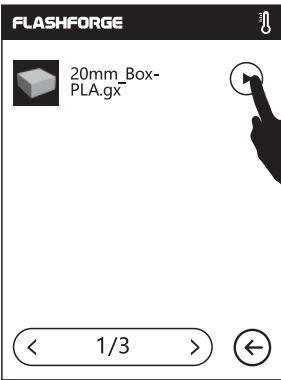

2. Locate the model file  in the model list, Tap  on its right to start printing; or tap model file picture or file name to enter model details page, tap  to start printing.

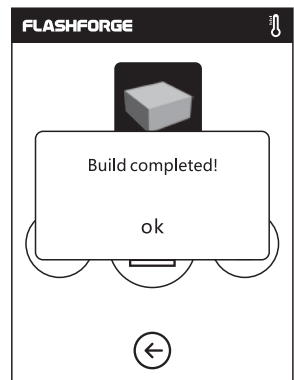
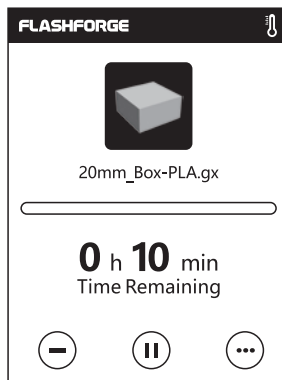
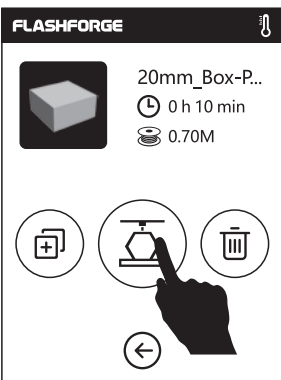

3. Extruder will heat up and printer will start printing after heating completed. After model printing finished, printer will sound a beep and pop out notice on touch screen.

Model Remove

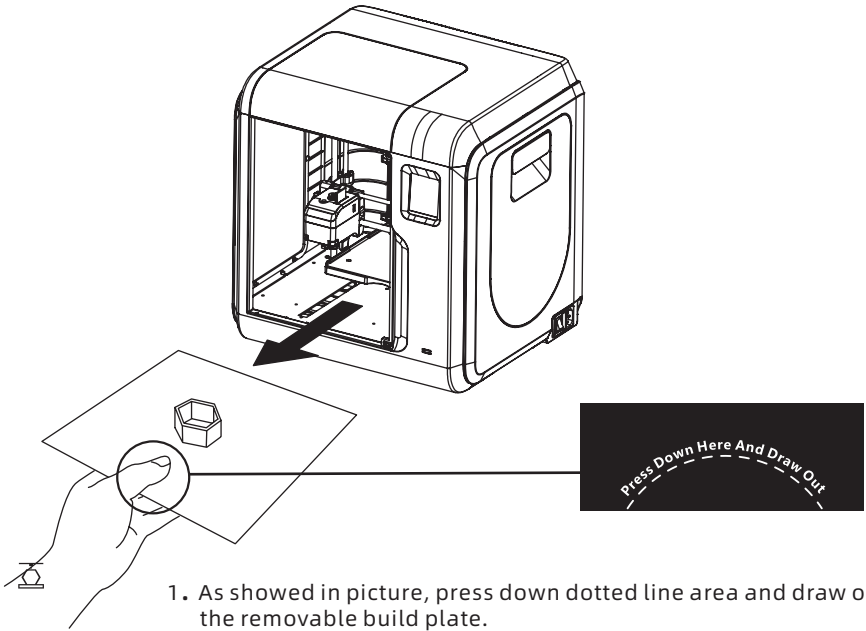

⚠ Notices

When printing completed, extruder and build plate may still hot, please start operating after cooling down!

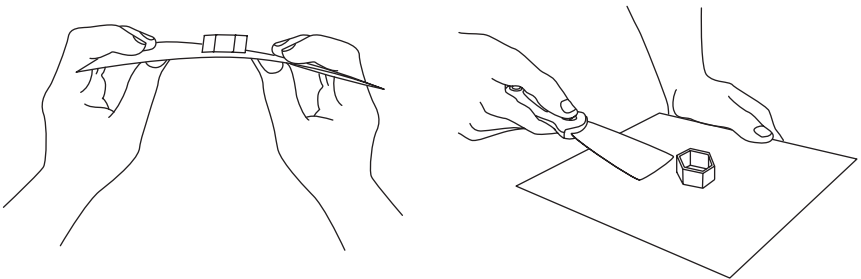

Change Filament

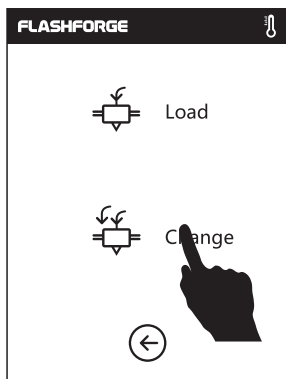

1. Tap [Filament], tap [Change], extruder starts preheating.

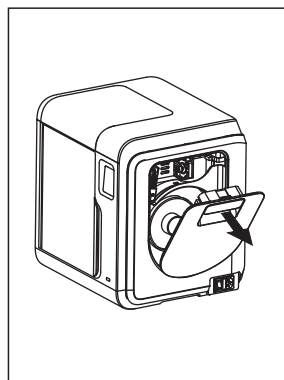
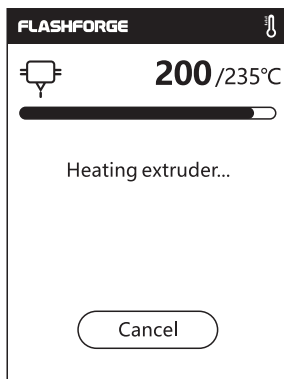

2. Open the filament cover.

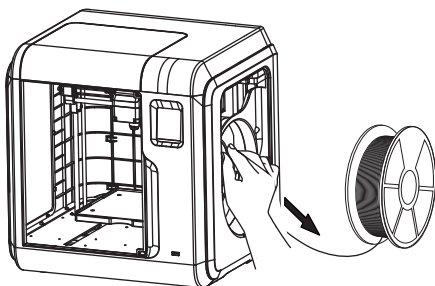

3. Pull out the filament as the picture showed above.

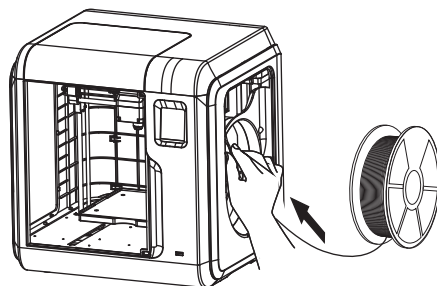

4. Insert new filament into the filament intake and push the filament into the feeding wheel until resistance is sensed.

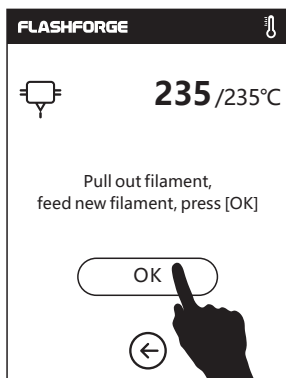

5. Tap [ok] after plugging in new filament, loading starts. When new filament come out of extruder steadily, replace is completed, tap [OK].

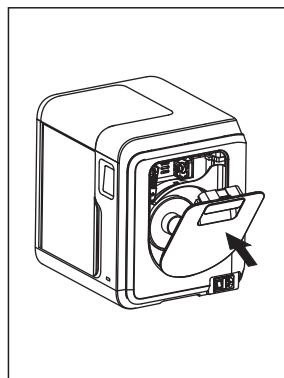
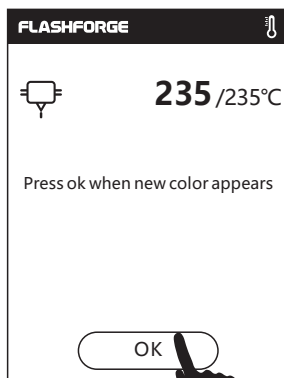

6. Put the spool of filament on the spool holder, close the filament cover.



**Scan QR to Get More
After-Sales Support**



Email: supports@flashforge-usa.com

Tel: (626)322-3855 Web: <https://flashforge-usa.com/>

Add: 17747 Railroad Street, City of Industry, CA 91748.