

FASCUT®

Model FS - 600 Rebar Cutter / Bender
Serial # 9478 and up



INSTRUCTION MANUAL

Built in the U.S.A. – Since 1979

FASCUT® Industries, 7248 Inama Rd., Sauk City, WI 53583

Phone: (608) 643-6678

Fax: (608) 643-2682

Website: www.fascut.com

Email: info@fascut.com

INTRODUCTION

FASCUT® incorporates both a cutter and a bender into one compact rebar fabrication machine. By following the enclosed instructions and maintenance schedule, your **FASCUT®** machine will provide you with years of trouble free service.

WARNING: DO NOT attempt to operate until you have read thoroughly and understand completely all instructions, rules, etc., contained in this manual. Failure to comply can and may result in accidents involving fire, electric shock, or serious personal injury. Maintain this instruction manual and review it frequently for continuing safe operation and instructing new or possible third-party users.

DO NOT: TURN ON MACHINE BEFORE REMOVING THE SHIPPING PLUG ON THE TOP OF THE OIL RESOVOIR AND REPLACING IT WITH THE SUPPLIED BREATHER CAP. FAILURE TO DO THIS COULD RESULT IN DAMAGE TO THE MACHINE!

ALWAYS: wear safety glasses when operating. **ALWAYS:** keep fingers away from cutting blades and bending rollers.

Model FS-600 Portable Bender/Cutter -- Specifications

Bend Capacity	1 bar - #6 ($\frac{3}{4}$ ") 19mm;	1 bar - #5 ($\frac{5}{8}$ ") 16mm
Grade 60 (420 MPa)	1 bar - #4 ($\frac{1}{2}$ ") 13mm;	2 bars - #3 ($\frac{3}{8}$ ") 10mm
Bend Angle Control	0 - 130°; infinitely variable with accurate repeat	
Bend Die Diameters	2 ($\frac{1}{2}$ ") and 3 ($\frac{3}{4}$ ") (64mm and 95mm)	
Bending Method	Three (3) point bending system	
Bend Time	Approx 3 seconds	
Shear Capacity	1 bar - #6 ($\frac{3}{4}$ ") 19mm;	1 bar - #5 ($\frac{5}{8}$ ") 16mm
Grade 60 (420 MPa)	2 bars - #4 ($\frac{1}{2}$ ") 13mm;	3 bars - #3 ($\frac{3}{8}$ ") 10mm
Shear Method	Open Jaw Shear	
Shear Time	Approx 2 seconds	
Dimensions (L x W x H)	26" x 13" x 16" 66cm x 33cm x 41cm	
Weight	180 pounds / 82kg; built in carrying handles	
Power Supply	Two stage hydraulic pump driven by a one (1) hp. continuous duty electric motor	
Voltage / Amps	110-120 volts @ 15 amps – 50/60 Hz, single phase 220-240 volts @ 7.5 amps – 50/60 Hz, single phase	

NORMAL OPERATION

1. **ALWAYS WEAR SAFETY GLASSES** when operating.
2. **ALWAYS KEEP FINGERS AWAY** from cutting blades and bending rollers.
3. **PLUG UNIT INTO** a 110-120Volt outlet on a circuit with no less than a 20 amp breaker. When using an extension cord, never use less than 12-guage wire. Excessive voltage drop at the unit will cause the motor to burn out.

Or if 220 Volt

WIRE UNIT TO a 220-240 Volt, 50/60 cycle, 1 phase power source. Unit will draw approximately 8 amps. When using an extension cord, never use less than 14-guage wire. Excessive voltage drop at the unit will cause the motor to burn out.

4. **GENERATOR MUST BE 5000 WATTS OR LARGER.** Disable idle down feature so generator engine is running at operating speed when turning on rebar cutter.
5. **TURN ON** using the toggle switch. In cold weather operations, turn unit on and allow to warm up for 5 to 10 minutes before using.
6. **ALWAYS TURN OFF** unit when not in use. **DO NOT** allow unit to idle for long periods of time.
7. **KEEP IN UPRIGHT POSITION** to prevent loss of hydraulic oil from the oil tank breather cap.
8. **TO CUT** a bar or bars, position bar between cutting blades. Bar must rest on the bottom of the cutter opening as shown on the diagram. Press the green button until cut is made and then release.

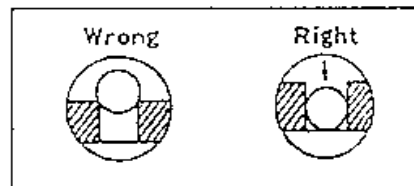

DO NOT cut very short pieces as they could fly out and cause personal injury to you or someone located close to you.

9. **TO BEND** a bar, rotate the adjustment knob to set the desired bend angle. Once set, all bends will be identical. Position bar between the bending rollers and bending die. Bar must be kept horizontal at all times.

BEND ONLY ONE BAR AT A TIME. Two $\frac{3}{8}$ " (#3) diameter bars or Three $\frac{1}{4}$ " (#2) diameter bars can be bent together.

DO NOT bend more than 1 - $\frac{1}{2}$ " (#4), 1 - $\frac{5}{8}$ " (#5) or 1 - $\frac{3}{4}$ " (#6) diameter bar at a time or injury to operator and/or damage to machine could result.

10. **TO CHANGE THE BENDING RADIUS** remove the bending die securing bolts with Allen wrench provided on the machine and rotate to desired radius. Move bending rollers to appropriate position by pulling drop pins up and out.

NOTE: *Bending rollers must be moved to the outside hole positions to be able to bend 5/8" (#5) or 3/4" (#6) diameter bar. With the rollers in the inside hole positions, only bars up thru 1/2" (#4) diameter will fit into the bender.*

BENDER SET-UP FOR SMALL RADIUS BENDS

Bending rollers are moved to the inside hole positions.

Bending die is secured in place with the **SMALL** radius facing the bending rollers.

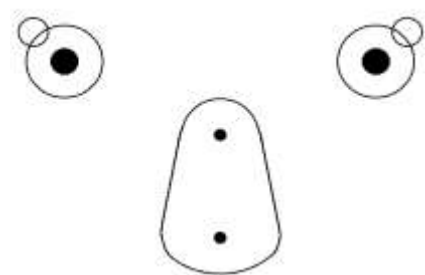

BENDER SET-UP FOR LARGE RADIUS BENDS

Bending rollers are moved to the outside hole positions.

Bending die is secured in place with the **LARGE** radius facing the bending rollers.

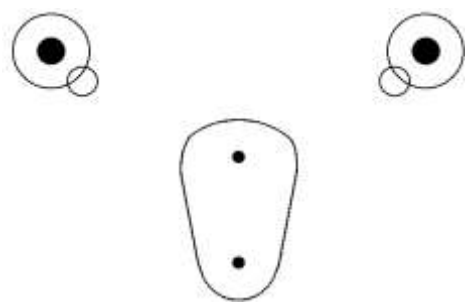

BENDER SET-UP FOR BENDING TIGHTER HOOKS USING UP TO 1/2" (#4) DIA. BAR

Bending rollers are moved to the inside hole positions.

Bending die is secured in place with the **LARGE** radius facing the bending rollers.

Maximum 1/2" (#4) dia. bar with this set-up!

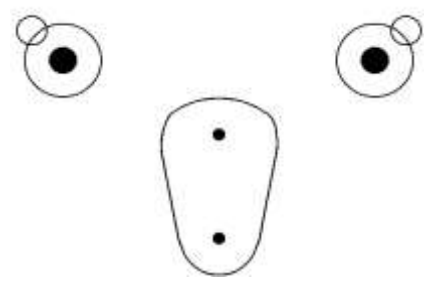

NOTE: *The bending die must be fastened using the 2 securing hex bolts and must be kept tight at all times or injury to operator and/or damage to machine could result.*

STIRRUP FABRICATION

Step 1: Determine dimensional size of stirrup to be fabricated.

Step 2: Determine the length of bar needed for specified stirrup using the following formula.

Stirrup “Cut” Factor

For #3 ($\frac{3}{8}$ ”) or #4 ($\frac{1}{2}$ ”) Rebar – Use the following formula.

Length X (2) + Width X (2) + 4” = Cutting Length

Example: 12” square stirrup – 12” X 2 = 24” + 12” X 2 = 24” + 4” == 52”

For #5 ($\frac{5}{8}$ ”) or #6 ($\frac{3}{4}$ ”) Rebar – Use the following formula.

Length X (2) + Width X (2) + 3” = Cutting Length

Example: 12” square stirrup – 12” X 2 = 24” + 12” X 2 = 24” + 3” == 51”

Step 3: Determine where to set reference fence in order to get the proper dimensional stirrup. Measurement is made from the center of the “pear” shaped bending die, to the fence.

Stirrup “Bend” Factor

If stirrup is square, adjust Fence using the following formula.

Length/Width – Diameter of Bar = Fence Position

Example: 12” square stirrup using #4 ($\frac{1}{2}$ ”) Rebar – 12” - $\frac{1}{2}$ ” == 11 $\frac{1}{2}$ ”

If stirrup is rectangular, adjust Fence using the following formula.

Length (minus) Diameter of Bar = Fence - “Right” Collar Setting

Width (minus) Diameter of Bar = Fence - “Left” Collar Setting

Example: 12” X 18” Stirrup using #4 ($\frac{1}{2}$ ”) Rebar

12” -- $\frac{1}{2}$ ” == 11 $\frac{1}{2}$ ” Setting for “Left” Collar

18” -- $\frac{1}{2}$ ” == 17 $\frac{1}{2}$ ” Setting for “Right” Collar

STIRRUP & HOOK BENDING SEQUENCE

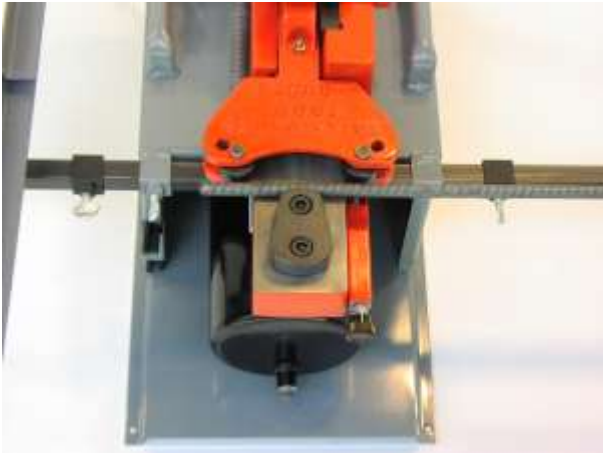

Bend #1

Position bar as shown;

Place end flush with the left side of the bending fork.

This is done by eye.

Bend 90°

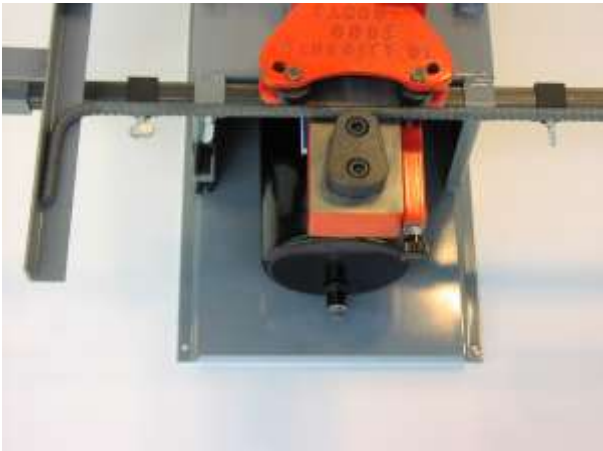

Bend #2

Reposition bar as shown;

Lay bent "hook" flat on the reference fence.

Bend 90°

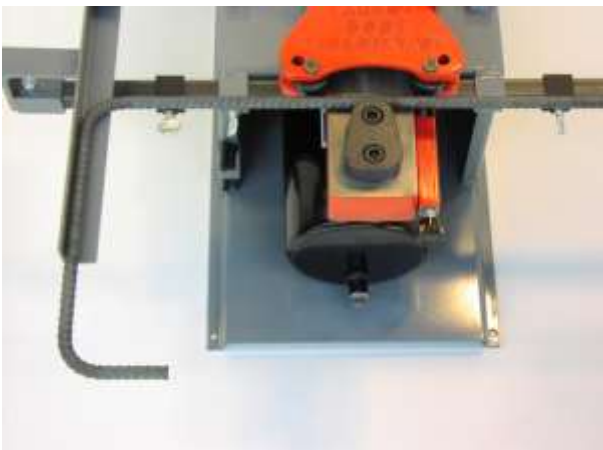

Bend #3

Reposition bar as shown;

Raise "hook" end of bar prior to bending.
(see Note below)

Bend 90°

Note:  Raise "hook" end of bar by the amount equal to the diameter of the bar.



Bend #4

Reposition bar as shown;

Raise “hook” end as bend is being made so hook ends up above the remaining bar.

Note: This is made easier because of raising “hook” end prior to bend #3.

Bend 90°

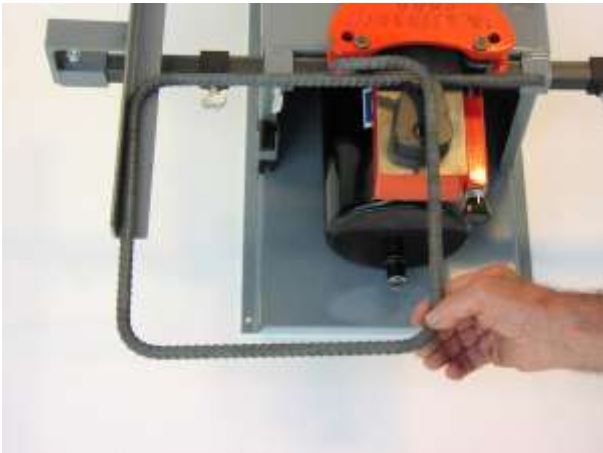

Bend #5

Reposition bar as shown;

While bending lift bar up slightly to slide up and over bending fork.

Bend 90°



PRESTO

(1)

CUSTOM STIRRUP

OPTIONS

REFERENCE FENCE ATTACHMENT

The reference fence can be adjusted to give the operator a material stop for cutting or bending uniformity. It is extremely useful in the fabrication of stirrups. Not only are all bends positioned properly, but all bends are in the same plane. The adjustable collars allow the operator to fabricate stirrups of different shapes, such as rectangular.



The FS-600 has the adapters for attaching the stop bar already built into the unit. No modification is required. Just slide it in and you are ready to go.

The reference fence attachment comes in 4 parts:

- 1) Thumb screw that is threaded into the left side adapter ring on the frame to secure the bar in the desired position.
- 2) A 60" length of 1" square steel bar.
- 3) T - shaped fence bracket that bolts to the end of the steel bar.
- 4) Two adjustable stop collars.

ASSEMBLY

Bolt the "T" shaped fence bracket to the end of the steel bar using the hardware included with the attachment. Next, slide one of the stop collars onto the bar with the thumb screw facing the operator. Now insert the bar thru the holder rings that are located on the frame from the LEFT side. Next, slide the other stop collar onto the bar with the thumb screw facing the operator from the right side. Finally screw the remaining thumb screw into the LEFT holder ring on the frame of the machine.

HOW TO USE

For normal operations, slide the fence left or right to the desired dimension and secure with the thumb screw. Use the two stop collars when making rectangular shaped stirrups. Push the fence to the right and set the left hand stop collar at the required dimension and secure with the thumb screw. Now push the fence to the left and set the right hand stop collar for the longer required dimension and secure with the thumb screw. Keep the thumb screw on the machine frame loose for this operation. The fence can now be slid alternately back and forth to each stop as the stirrup is being made.

FOOT PEDAL CONTROL



The Foot Pedal comes fully assembled and pre-wired. It can be plugged in at any time.

A jack is provided on the underside of the electric box. Push the plug into the jack until it locks in place. To remove, just push the release button on the jack.

When the foot pedal is plugged in, both the push button on the machine and the foot pedal will control the machine.

Note: *Extra caution must be observed when using the foot pedal to keep fingers away from cutting blades and bending rollers.*

Never: *Have one person work the foot pedal while another is feeding rebar into the machine.*

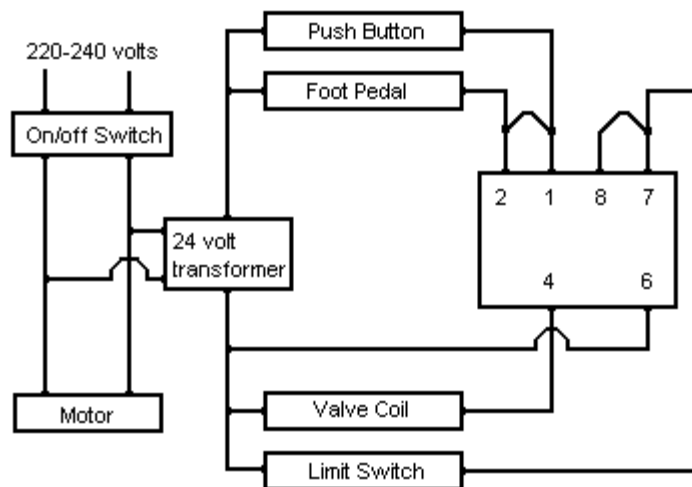
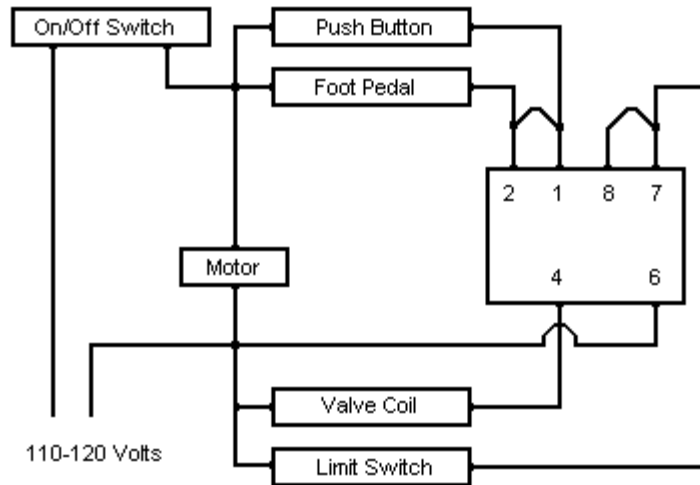

The on/off switch turns on power to both the electric motor and the valve coil control circuit. It must be 1 HP rated.

Pressing the push button or foot pedal completes the circuit to energize the valve coil. The limit switch is spring loaded and normally open. It is triggered by the slide casting when it moves out. When the limit switch is closed, it triggers the relay which will open the valve coil circuit, causing the slide casting to retract.

ROUTINE MAINTENANCE

- 1) **DRAIN & REPLACE HYDRAULIC OIL** at least once each year or 200 operating hours, whichever comes first. Allow unit to run for five minutes before draining to warm up the oil. Remove drain plug to drain oil. Remove breather cap to fill. Leave one (1) inch of air in the tank. **DO NOT OVERFILL**. Ease the breather cap back into the hole taking care not to push the rubber grommet into the tank. Use good quality hydraulic oil with a rating of **ISO-VG 46** for general year round use. Use heavier ISO VG-68 for continuous hot weather operation. The unit will take approximately 6 quarts of oil to refill.

Failure to re-install the breather cap will result in damage to the machine.

- 2) **GREASE** fitting on slide casting before **EACH** use period. Re-bar scale will quickly dry up grease. Removal of this scale often will help to reduce wear.

Failure to remove excessive scale and lubricate machine regularly, could result in increased wear and reduced life of the machine.

- 3) **TIGHTEN** blade securing hex bolts and bending die hex bolts with the supplied Allen wrenches before each use period.

Failure to keep cutting blades or bending die securing hex bolts tight at all times could result in injury to the operator and/or damage to the machine.

- 4) **CUTTING BLADES** have 8 indexable cutting edges. When one set of edges is worn out, simply remove blade securing bolt and rotate to a new edge. If old edge has mushroomed slightly, grind edge flat before installation to achieve proper "seating" of the blade in its new position.

Do not attempt to re-sharpen worn edges. You will change the hardening properties of the blade and reduce its overall useful life.

FASCUT® Model FS-600 Rebar Fabricator

Parts List for serial # 9478 and up

Breakdown A

Prices subject to change without notice. Jan 1, 2019

Index #	Description	Part #	Price/ea.	Qty Req'd
1	Bend adj. knob	62154	3.30	1
2	Bend adj. mechanism (includes knob)	62158	53.52	1
3	Bend adj. mounting bolt	62423	.20	2
4	Bend adj. mounting star washer	62427	.10	2
5	Bending Die	63221	67.05	1
6	Bend die securing bolt	63351	2.52	2
7	Bending roller (1-3/8" dia.)	63444	24.00	2
8	Bending roller securing drop pin	63475	4.30	2
9	Casting, base	64531	534.00	1
10	Casting, slide	64533	289.00	1
11	Casting (LB mounting bolt w/nut)	71522	1.65	1
12	Casting (LF mounting bolt – dome head)	71525	1.20	1
13	Casting (RF mounting bolt)	71529	1.30	1
14	Casting (mounting bolt star washer)	71533	.15	3
16	Cutting blade set w/bolts and washers	FAS600	75.00	1
17 & 18	Extra blade hardware set	FAS600b	1.75	1
19	Grease fitting	62547	1.24	1
20	Hydraulic Cylinder – complete	67425	647.00	1
	Hydraulic cylinder front block	67567	228.00	
	Hydraulic cylinder back block	67568	145.00	
	Hydraulic cylinder tube	67566	89.00	
21	Hyd Cyl. Body seal kit	67523	18.00	1
22	Hyd Cyl. Elbow fitting	73112	17.52	2
23a	Hyd Piston & rod assy. 4-3/4", #6993 +	67536	194.00	1
23b	Hyd Piston & rod assy. 5", #6726-6992	67564	194.00	
24	Hyd Piston seal and loader ring	67672	32.50	1
25a	Hyd Nylon rod bearing, #6896 +	67785	3.95	1
25b	Hyd Brass rod bearing, #6726-6895	67781	18.20	
26	Hyd Rod seal and wiper	67822	15.97	1
27	Limit switch (side wire)	74341	95.97	1
28	Limit switch mounting screw	74352	.10	2
29	Limit switch mounting lock washer	74354	.05	2
30	Limit switch trigger bolt w/nut	74356	1.25	1
31	Return spring	68386	9.21	1
32	Return spring slide casting bolt	77105	1.10	1
33	Safety cover plate w/decal	68642	7.29	1
34	Safety cover plate attach screw	68644	.15	2
35	Tie rod	69921	6.75	4
36	Tie rod nut	69923	.89	4

Breakdown B

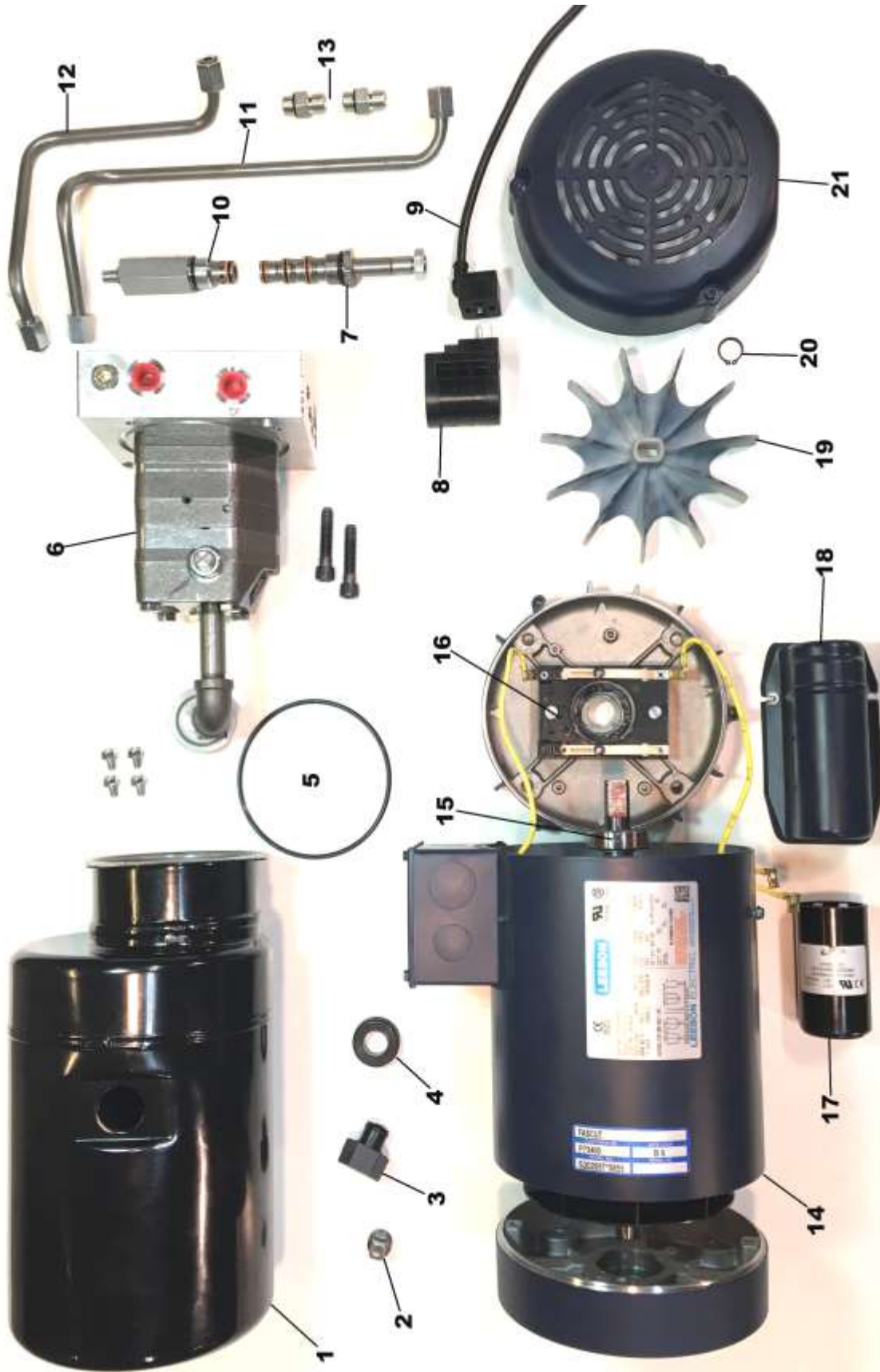

FASCUT® Model FS-600 Rebar Fabricator

Parts List serial # 9478 and up

Breakdown B

Prices subject to change without notice. Jan 1, 2019

Index #	Description	Part #	Price/ea.
1	Oil Tank, steel	76407	89.00
2	Oil tank drain plug	76245	.79
3	Breather cap	71063	9.00
4	Breather cap grommet	71064	2.70
5	Oil tank o-ring (steel tank)	76423	9.00
	Oil tank o-ring (plastic tank)	76424	9.00
6	Hydraulic Pump/valve block (MTE 600)	73426	634.00
7	Valve, directional #8 (serial #9478 – 9492)	78920	94.35
	Valve, directional #10 (serial #9493 and up)	78921	94.35
8	Valve coil, 110-v, #8 (serial #9478 – 9492)	78935	71.40
	Valve coil, 110-v, #10 (serial #9493 and up)	78936	71.40
	Valve coil, 24-VAC for 220-v units (serial #9493 and up)	78934	71.40
9	Valve coil cable	78940	27.48
10	Valve, pressure shut down	78989	102.11
11	Rear pressure tube w/nuts-ferrules (serial #9478 – 9492)	67951	12.60
	Elbow fitting (SAE) for serial #9478 – 9492. (not shown on breakdown)	73112	17.52
	Rear pressure tube w/nuts-ferrules (serial #9493 and up)	67953	12.60
12	Front return tube w/nuts-ferrules (serial #9478 – 9492)	67927	12.60
	Elbow fitting (NPT) with SAE extension for serial #9478 – 9492. (not shown on breakdown)	73114	19.65
	Front return tube w/nuts-ferrules (serial #9493 and up)	67929	12.60
13	Fitting, straight connector (SAE) (serial #9493 and up) (two required)	73119	15.20
14	Electric Motor	75703	673.00
15	Motor shaft bearing (2 req'd)	75872	16.02
16	Motor starting switch	75890	29.50
17	Motor starting capacitor (540-648 uf)	77256	18.07
18	Motor starting capacitor cover	77255	26.45
19	Motor fan	75736	27.09
20	Motor fan retaining ring	75737	.50
21	Motor fan guard	75723	37.62

Breakdown C



FASCUT® Model FS-600 Rebar Fabricator

Parts List serial # 9478 and up

Breakdown C

Prices subject to change without notice. Jan 1, 2019

Index #	Description	Part #	Price/ea.
1	Electric box only – 110-v	66745	73.65
	Electric box only – 220-v	66746	86.05
2	Electric box, wired – 110-v	66785	269.00
	Electric box, wired – 220-v	66786	297.00
3	Electric box mounting bolt (each)	71932	.25
4	Electric box star washer (each)	71938	.15
5	Motor connecting cord	75826	2.45
6	Cord grip (each)	71814	3.85
7	Relay socket	76953	7.80
8	Relay – 110-v	76951	23.55
	Relay – 24-v for 220-v unit	76952	30.39
9	Foot pedal socket	72373	23.66
10	Terminal block	77837	4.85
11	Push button control	76882	25.50
12	On/Off switch – 110-v	76619	8.12
	On/Off switch – 220-v	76620	9.60
13	On/Off switch boot	76633	2.97
14	Power cord w/plug – 110-v	76745	12.28
15	Allen wrench (3/8")	61048	4.36
16	Allen wrench (5/16")	61046	3.86
17	Motor mounting bolt (each)	75788	.30
18	Motor mounting nut (each)	75791	.30
19	Reference fence thumb screw	77554	1.15
20	Frame	66855	198.00
21	Hydraulic Power unit, complete	73407	1550.00
Xxx	Transformer, 24-v for 220-v unit (not shown)	78101	26.52
	Foot Pedal Control - standard	72365	129.00
	Foot pedal cord w/plug - standard	72369	27.50
	Foot pedal Safety Decal	71949	1.98
	Reference Fence Attachment	69725	75.00
	Reference fence head only	69727	55.00
	Reference fence collar w/thumb screw	77448	7.60

TROUBLESHOOTING FS-600 Rebar Cutter/Bender

TROUBLE	PROBABLE CAUSE	REMEDY
Motor will not start	<ol style="list-style-type: none"> 1. No power to unit. 2. Power cord or plug damaged. 3. On/off switch bad. 4. Motor wire connections loose. 	<ol style="list-style-type: none"> 1. Check supply cord, fuses, or circuit breaker. 2. Replace power core w/plug. 3. Replace on/off switch. 4. Tighten motor wire connections.
Motor hums, then blows circuit breaker, or motor is smoking	<ol style="list-style-type: none"> 1. Extension cord too long or not heavy enough. 2. Starting capacitor bad. 3. Starting switch bad. 4. Generator too small. 5. Generator running at idle before starting unit. 6. Motor windings burnt out. 	<ol style="list-style-type: none"> 1. Extension cord must be min. 12 gauge wire and no longer than 100 feet. 2. Replace starting capacitor. 3. Replace starting switch. 4. Use a 5 KW generator or larger. 5. Turn off or disconnect idle down feature. 6. Replace motor.
Motor runs, but nothing happens when push button is depressed.	<ol style="list-style-type: none"> 1. Relay has fallen out of its socket. 2. Relay socket is broken. 3. Bend angle adjuster is bent or damaged. 4. Bend angle adjuster is always triggering the limit switch. 5. Limit switch is bad. 6. Relay is bad. 7. Push Button is bad. 8. Loose wire. 9. Valve coil is bad. 10. Directional valve is bad. 	<ol style="list-style-type: none"> 1. Plug relay back into socket. 2. Replace relay socket. 3. Replace angle adjuster. 4. Readjust by loosening the jam nut behind the adjuster knob. Rotate the knob 1 turn counterclockwise and then retighten the jam nut. 5. Replace limit switch. 6. Replace relay. 7. Replace push button. 8. Check all wiring for loose connections. 9. Replace valve coil. 10. Replace directional valve.
Foot Pedal does not work. (push button does)	<ol style="list-style-type: none"> 1. Foot pedal cord or plug is damaged. 2. Jack is bad. 3. Switch inside foot pedal is bad. 	<ol style="list-style-type: none"> 1. Replace foot pedal cord w/plug. 2. Replace jack. 3. Replace inside switch.
Slide casting does not return	<ol style="list-style-type: none"> 1. Slide casting needs lubrication. 2. Something is jammed behind slide casting. 3. Slice casting is bent. 4. Weak return spring. 	<ol style="list-style-type: none"> 1. Apply WD-40 to slide casting to loosen rebar scale and old grease. Grease more often thru grease fitting. 2. Remove object jammed behind slide casting. 3. Replace slide casting or attempt to straighten. 4. Replace return spring.

Slide casting is bent	<ol style="list-style-type: none"> 1. Steel being bent is taller than gap between base casting and the plate between the bending rollers. 2. Tails of long bars being bent are dropping down, causing the bent bar to pry up on the slide casting. 3. A piece of material has been pinched between the bending die and the plate between the bending rollers. 	<ol style="list-style-type: none"> 1. Maximum bending capacity is $\frac{3}{4}$", #6 rebar or smaller, ONE BAR AT A TIME. 2. Support the ends of rebar being bent with a table or platform or extra worker holding onto end of bar. 3. Rest steel being bent flat on the base casting.
Cutting blade bolts breaking	<ol style="list-style-type: none"> 1. Cutting blade bolts are loose. 2. Cutting blades are dull. 3. Blade socket is deformed. 	<ol style="list-style-type: none"> 1. Retighten blade bolts regularly. 2. Turn blades to new cutting edge or replace blades. 3. Replace casting.
Cutting blades breaking	<ol style="list-style-type: none"> 1. Blades are dull. 2. Blade bolts are loose. 3. Rebar is being dropped into the cutter. 4. You are cutting "no grade" steel 5. Bar is being cut on the top corner of the cutting blade 	<ol style="list-style-type: none"> 1. Turn blades to a new edge sooner. 2. Check blade bolts for tightness more often. 3. Place rebar into the cutter with greater care. 4. Only cut grade 40 or grade 60 rebar. 5. Bar must rest on the bottom of the cutter opening.
Bending roller drop pin breaking	<ol style="list-style-type: none"> 1. Configuration of bending die and rollers is incorrect for material being bent. 2. Already bent steel is being placed back into the bender and bent a second time after moving bending rollers to the inside hole positions. 3. Steel is harder than Grade 60 rebar. 	<ol style="list-style-type: none"> 1. See instruction manual for correct die and roller positions. 2. Only bend straight bars ONCE. 3. Do not bend steel harder than Grade 60 rebar.
Oil is leaking	<ol style="list-style-type: none"> 1. Hydraulic tubes and fittings are loose or damaged. 2. Hydraulic cylinder body seals or rod seal is leaking 	<ol style="list-style-type: none"> 1. Check fittings for tightness. Replace damaged fittings or tube. 2. Install new body and/or rod seals in hydraulic cylinder.
Cutting is slow and lacks power	<ol style="list-style-type: none"> 1. Oil level is low. 2. Oil is contaminated. 3. Hydraulic pump is worn. 	<ol style="list-style-type: none"> 1. Add oil to tank. 2. Drain and refill oil tank with fresh ISO-46 hydraulic oil. 3. Replace hydraulic pump.

FASCUT® Industries, Inc.

LIMITED WARRANTY

This product has been thoroughly inspected and tested before leaving the factory. It is guaranteed against defective workmanship and materials for a period of 1 year to the original owner. Should any trouble develop, return defective part transportation prepaid to the factory. If inspection shows trouble is caused by defective workmanship or material, all repairs will be made without charge and returned, transportation prepaid. The guarantee does not apply where: repairs or attempted repairs have been made by persons other than the factory; repairs are due to normal wear; the tool has been abused or in an accident; misuse is evident – caused by overloading the tool beyond its rated capacity; use on improper voltage or current; use of the tool after partial failure or use with improper accessories.

This warranty is in lieu of all other warranties, expressed or implied, and there are no warranties on merchantability or fitness for a particular purpose. In no event shall seller be liable for incidental, consequential or special damages. This warrantee is void if Warrantee/Registration card is not filled out and returned. This warranty gives you specific legal rights, and you may also have other rights, which vary from state to state.

SERIAL NUMBER _____ **DATE** _____

FASCUT® Industries, Inc.

7248 Inama Rd.

Sauk City, WI 53583

Phone: (608) 643-6678

Fax: (608) 643-2682

www.fascut.com