



Model 2, 2-1/2, 2B

Compound Leverage Arbor Press

Instruction and Parts list

MODEL 2

<u>Item</u>	<u>Part Name</u>	<u>Part No.</u>
1	Main Casting – Model 2 only	194
2	Spindle	224
3	Compound Rest Pin	217
4	Pawl	211
5	Pawl Pin	219
6	Lever weight	210
7	Compound	209
8	Lever weight Pin	220
9	Retaining Ring Truarc 5160-118	67955
10	3/8"x5/8" Socket Head Set Screw	43446
11	Handle	218
12	Short Sliding Pin	222
13	Retaining Ring Nat'l 2SO-230	43978
14	3/8"x1" Socket Head Set Screw	43591
15	Hand wheel	232
16	Long Sliding Pin	221
17	Ram (1-1/2" x 1-1/2" x 19")	212
18	Name Plate	112

19	3/8"x1-1/4" Hex Cap Screw	43330
20	Ram Cap	201
21	Hand Brake Clamp	215
22	Hand Brake Stud	223
23	Hand Brake	214
24	Shim Paper (.008")	207
	Shim Paper (.015")	208
25&26	Table Plate Assembly Model 2	700936

MODEL 2-1/2

1	Main Casting – Model 2 1/2 only	233
17	Ram (1-1/2" x 1-1/2" x 27")	234

MODEL 2B

1	Main Casting – Model 2B only	228
1	Table Plate Assembly Model 2B	700937

Please contact factory for current prices.

This press can be operated with either simple or compound leverage. Simple leverage is used for exerting lighter pressures and the compound leverage is used for heavier pressures. If simple leverage is desired slide the short pin No. 222 to the left to its farthest position. Compound leverage is obtained by sliding the long pin No. 221 to its farthest right hand position, thereby disengaging simple leverage pin.

Ordering information: Please order all repair parts by part number and name, also mention model number of press. All parts are shipped F.O.B. Factory in Grand Haven, MI.

Lubrication: Keep all working parts of the press well oiled for easier operation. Also keep a light film of oil over the entire surface of the ram to prevent rust.

DAKE

Division of JSJ Corp.
724 Robbins Road
Grand Haven, MI 49417

Phone: 616-842-7110 800-937-3253
Fax: 616-842-0859 800-846-3253
E-Mail: customerservice@dakecorp.com
technicalservice@dakecorp.com
Website: www.dakecorp.com

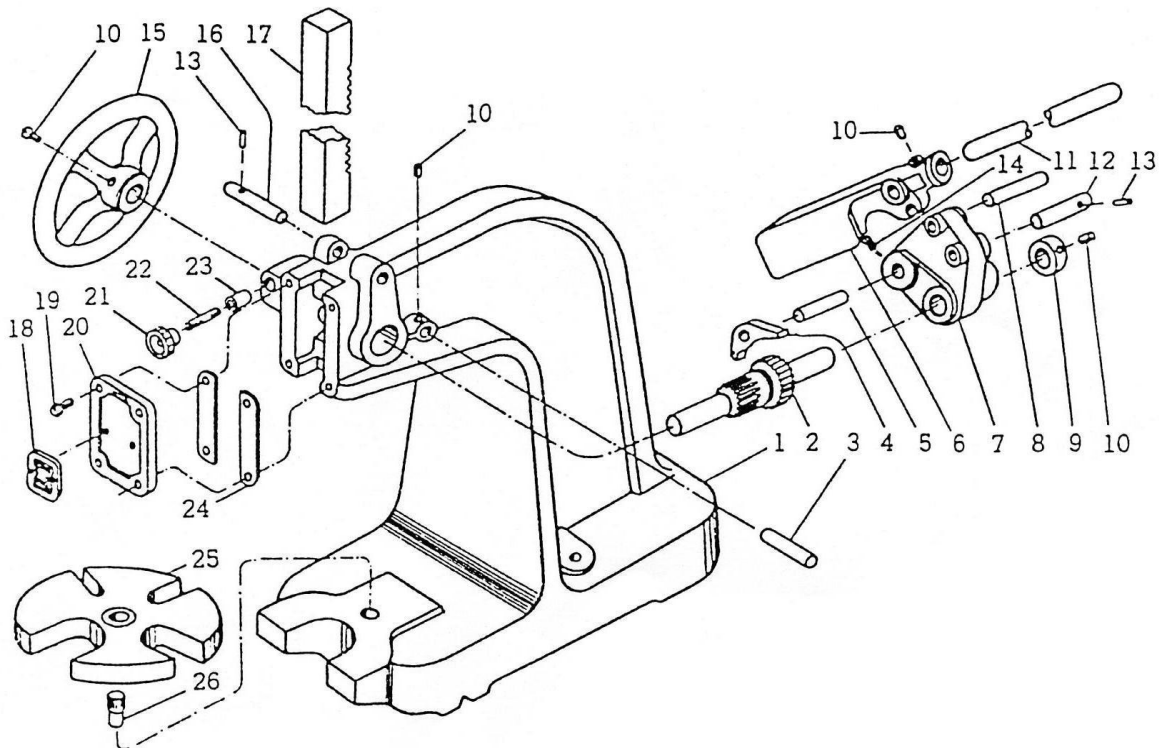

Label Part No. 300168

Label Part No.
300168

⚠ WARNING		
		
Establish solid footing to prevent falls.	Keep hand away from point of operation. Read instructions.	Guard workpiece to prevent projectiles from reaching operator. Wear eye protection.

⚠ WARNING
Equipment must be securely anchored to prevent tipping.



SAFETY

This is the safety alert symbol. When you see this symbol on your press, be alert to the potential for personal injury.

Follow recommended precautions and safe operating practices.

<p>Carefully read all safety messages in these instructions and on your press safety signs. Keep safety labels in good condition. Replace missing or damaged safety labels.</p>	<p>This machine is intended to be operated by one person. This person should be conscious of the press ram movement not only for themselves but also for persons in the immediate area of the machine.</p>	<p>Under no circumstances increase the leverage ratio of the press by using a longer handle or by placing a pipe over the handle. Never hammer on top of the ram.</p>
--	---	--

NOTE: Please refer to parts drawing for identification of components outlined on this safety warning sticker.

Model: 2, 2 ½ and 2B

⚠ WARNING



Beware of pinch points, handle to frame and ram to table or work.

Beware handle can free fall if pawl and gear are not engaged.

Never pull handle beyond horizontal plane allowing disengagement of pawl and gear.

Always bring ram to work or table with handwheel while holding pressing handle up ensuring engagement of pawl and gear.

Frame - Item 1 (Main Casting)
Table Plate Assembly - Items 26 & 27 (Part Number 700936)
Table Plate Assembly - Items 26 & 27 (Part Number 700937)

Pawl - Item 4
Gear - Item 2 (Spindle)
Handle - Item 11 (Spindle)

Handle - Item 11
Pawl - Item 4
Gear - Item 2 (Spindle)

Ram - Item 17
Table Plate Assembly - Item 26 & 27
Pawl - Item 4
Gear - Item 2 (Spindle)
Hand wheel - Item 15



Safety

This is the safety alert symbol. When you see this symbol on your press, be alert to the potential for personal injury.