**CHALLENGER MODEL 1800
PLASTIC MULCH LIFTER**

**OPERATING
MANUAL**

Rain-Flo Irrigation

929 Reading Road
East Earl, Pa 17519
PH: 717-445-3000

Table Of Contents

Center Colter	3
Cutting Discs	3
Depth Wheels	4
Features	13
Helpful Tips.....	13
Parts Breakdown, Descriptions	9-11
Parts Breakdown, Exploded Views.....	6-8
Plastic Width.....	5
Safety First	2
Top Link Adjustments.....	3
Trip Adjustments	5
Trouble Shooting	14
Warranty	12

!! Safety First !!

- ⚠ Keep people away when lifting and lowering the machine.
- ⚠ Do not crawl under the machine when lifted.
- ⚠ Do not adjust the machine when it is moving.
- ⚠ Be careful when turning around.
- ⚠ Do not stand on machine.
- ⚠ Stay clear from lifting prongs.
- ⚠ Rotating discs are sharp; keep hands away.
- ⚠ Tractor operator is responsible for extra worker (s) around machine.
- ⚠ Rain-Flo Irrigation is not responsible for accidents if any should occur.



Center Couler
Adj.

Vine Cutting
Disc Adj.

ADJUSTMENTS FOR VINE CUTTING DISC

Discs need to cut vines but not plastic.

Adjust side discs in line or a little to the outside of the lifting shanks.

Note: Top link can be lengthened to avoid front disc from cutting too deep. Setting discs too deep will keep machine from going down.

CENTER COULER

Center couler is to cut plastic in half for easier removal. With most crops, the center couler is very helpful; plastic will pull away easier when split in half.

Avoid adjusting it too deep.

Note: Center couler can also be removed if not needed.



Depth Wheel Adj.
Slide up 6" to 8" before use.

Top of Share Bracket
Keep 6" to 8" below plastic.

DEPTH ADJUSTMENT

Depth wheels need to be adjusted so that top of plow share stays approximately 4" to 6" below the plastic. Adjust lifting prongs to proper height that will lift plastic, but not too high that it will restrict plastic flow.

Note: Running machine too shallow may cause vines to drag or clog up plastic flow.

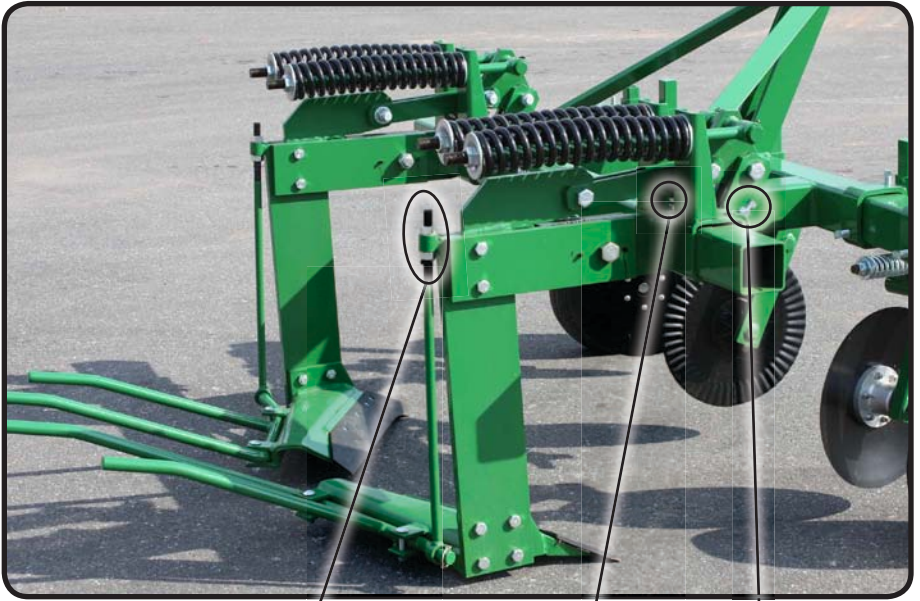

Prong
Height Adj.

Trip Adj.

Plastic
Width Adj.

PLASTIC WIDTH ADJUSTMENT

Adjust shanks approximately 6” wider than each side of the plastic bed top.

Adjustment is done by unlocking set screws and sliding shanks in or out.

TRIP ADJUSTMENT FOR AUTO RESET

Trip adjustment is under the front of the springs. For an easier trip turn bolt down; turn bolt up for a harder trip.

STANDARD 1800 LIFTER

#388

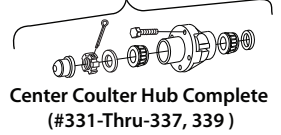

#461

Center Disc Complete
(#401 -thru- #407,411
331 - thru- 339)

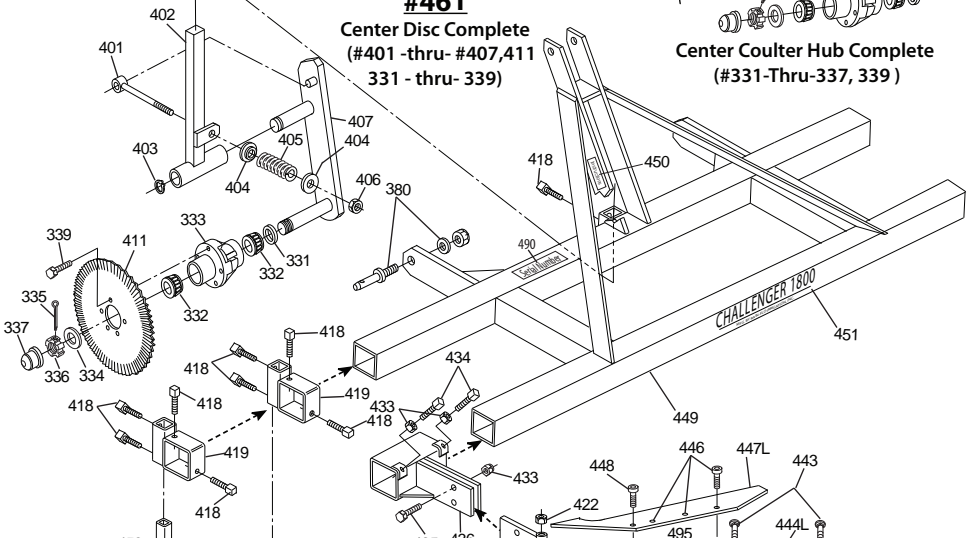

#463L

Complete shank Assembly
(#433 -thru- #448)

#464

Depth wheel complete
(#50-thru-#54,452)

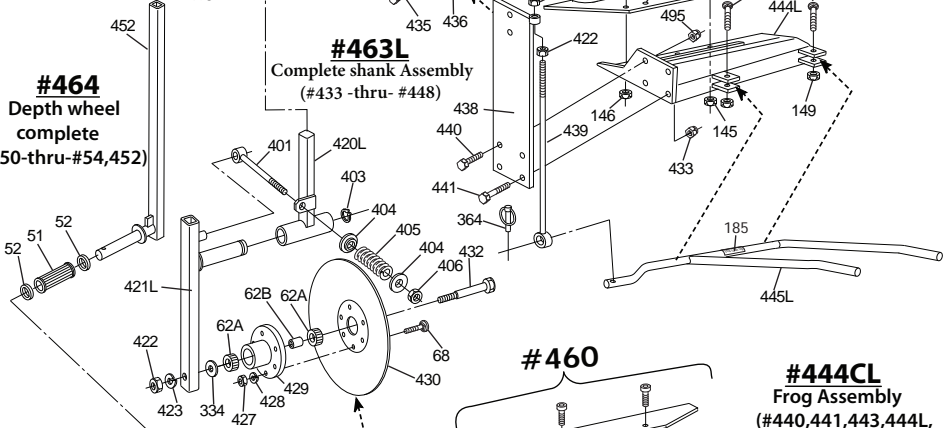

#460

Shear complete set

#444CL

Frog Assembly
(#440,441,443,444L,
446,447,448)

#462L

Side Disc complete
(#401, 403 -thru- 406,
420L -thru-432,
334,62A,62B,68)

#459

Side Disc Hub Complete
62A,62B,68,422,423,334,429,432

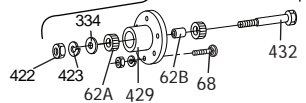
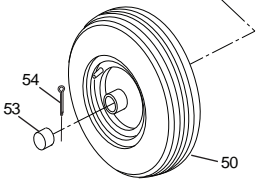

AUTO RESET 1800 LIFTER

#388

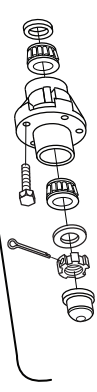

Center Coulter Hub Complete
 (#331-Thru-337, 339)

#461

Center Disc Complete
 (#401 -thru- #407,411
 331 - thru- 339)

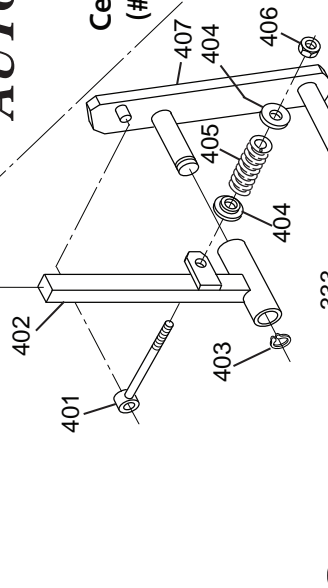

7

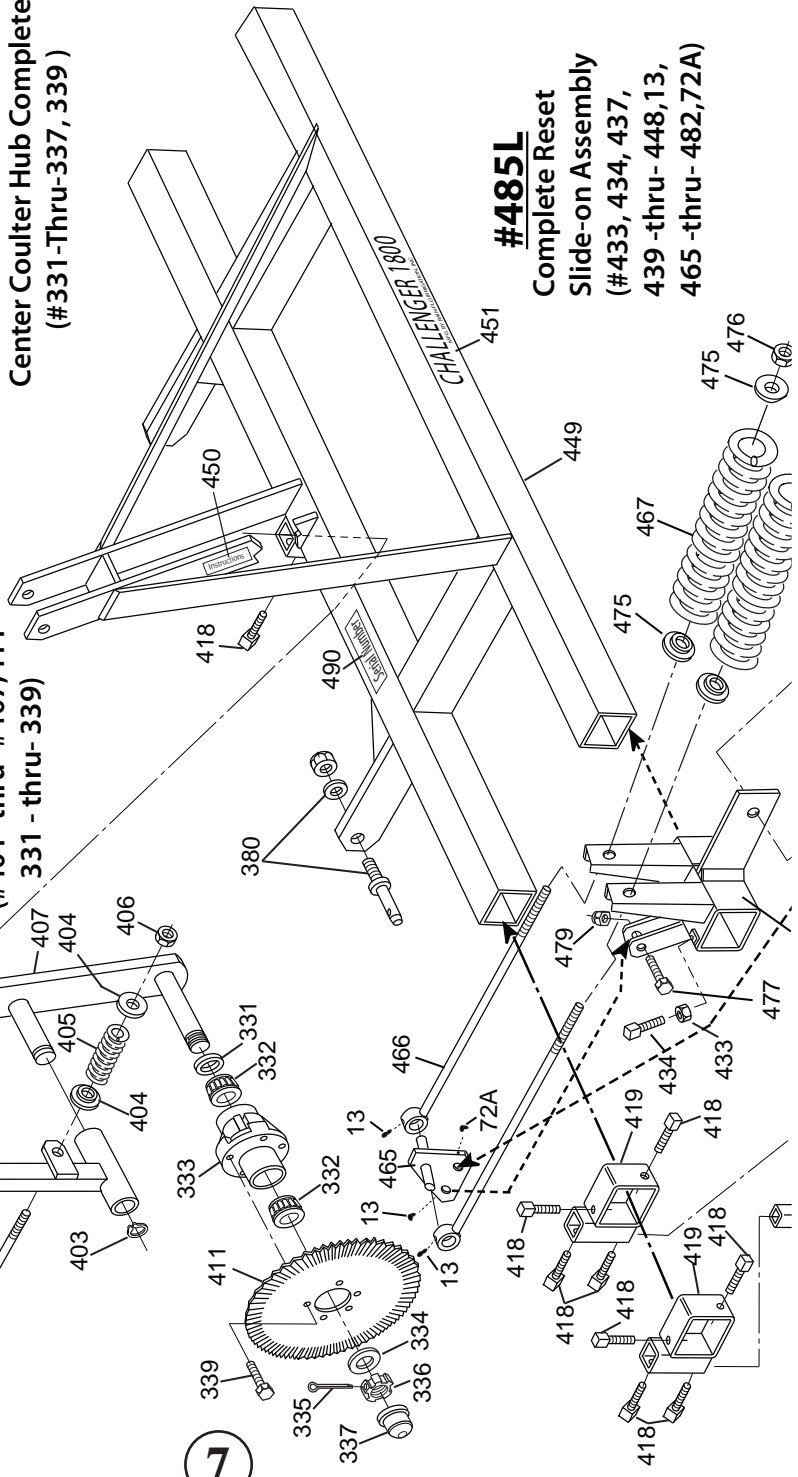

#485L

Complete Reset
Slide-on Assembly
 (#433, 434, 437,
 439 -thru- 448, 13,
 465 -thru- 482, 72A)

#444CL
Frog Assembly
 (#440, 441, 443, 444L,
 446, 447, 448)

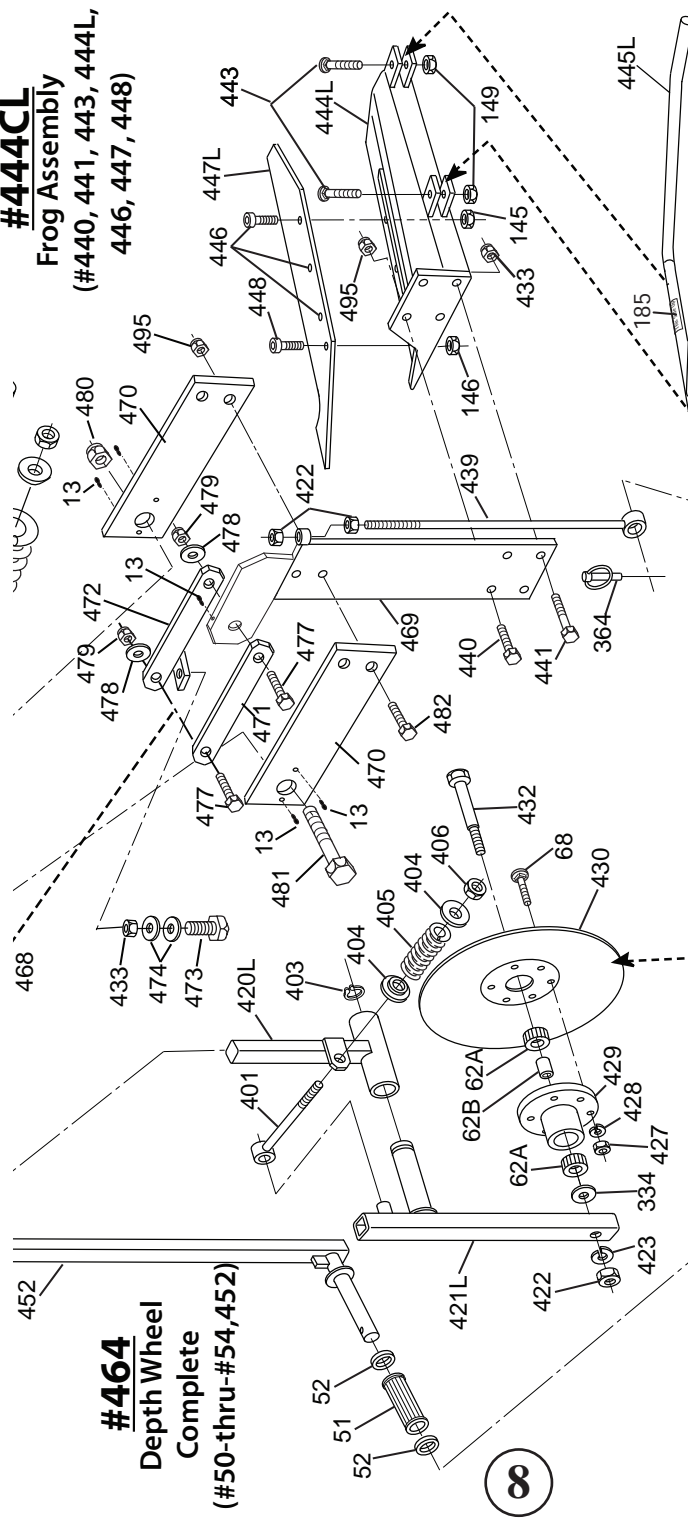

#459

Side Disc Hub Complete
 62A, 62B, 68, 422, 423, 424, 429, 432

#462L

Side Disc complete
 (#401, 403-thru-406,
 420L-thru-432,
 334, 62A, 62B, 68)

#460

Shear Complete set

#464
Depth Wheel Complete
 (#50-thru-#54, 452)

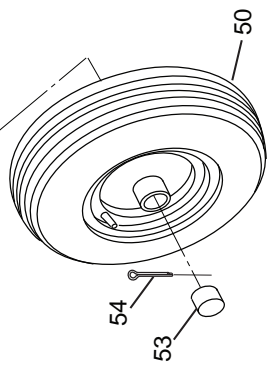

PARTS LIST

ITEM #	DESCRIPTION
13..... (11)	1/4" NFT Straight Grease Zert
50..... (2)	Wheel Complete with Bearings
51..... (2)	Needle Bearing
52..... (4)	Retainer
53..... (2)	Hub Cap
54..... (2)	Cotter Pin
62A..... (4)	Bearing
62B.....	Spacer
68..... (12)	Bolt 3/8" x 1 1/2"
72A..... (2)	1/4" NFT 45* Grease Zert
145..... (6)	7/16" hex nut
146..... (2)	1/2" hex nut
149..... (4)	1/2" nylon lock nut
185..... (2)	This Side Up label
331.....	Seal
332..... (2)	Bearings
333.....	Hub only
334..... (3)	SAE Washer
335.....	Cotter Pin
336.....	Nut
337.....	Hub Cap
339..... (5)	Bolt
364..... (2)	Lynch Pin
380..... (2)	Lift Pin Category II
388.....	Center coulter hub complete
401..... (3)	Eye Bolt
402.....	Center Coulter Stem
403..... (3)	Snap Ring 3/4"
404..... (6)	Pressed Washers
405..... (3)	Spring
406..... (3)	Nut
407.....	Center Coulter Hinge Arm
411.....	Blade 16" 5-bolt wavy (center coulter)
418..... (18)	Set Screw 5/8" x 1 1/2"
419..... (4)	Clamp
420L.....	Side Disc Stem "Left Side"
420R.....	Side Disc Stem "Right Side"
421L.....	Side Disc Arm "Left Side"
421R.....	Side Disc Arm "Right Side"
422..... (6)	Nut 3/4"

PARTS LIST

ITEM #	DESCRIPTION
423..... (2)	Lock Washer 3/4"
427..... (12)	Nut 3/8"
428..... (12)	Lock Washer 3/8"
429..... (2)	Alum. Hub only
430..... (2)	Blade 16" 6 hole
432..... (2)	Bolt 3/4" x 5"
433..... (12)	Nut 5/8"
434..... (4)	Set Screw 5/8" x 2"
435..... (4)	Nut & Bolt 5/8" x 3 1/4" (Shear)
436..... (2)	Shank Bracket
438..... (2)	Standard Shank
439..... (2)	Adjusting Rod
440..... (4)	Top Jam Nut & Bolt 5/8" x 2 1/4"
441..... (4)	Bottom Nut & Bolt 5/8" x 2 1/2"
443..... (4)	1/2" x 2 3/4" carriage bolt, lock nut
444L.....	Left Side Plow Shear Mounting Bracket
444R.....	Right Side Plow Shear Mounting Bracket
444CL.....	Left Side Frog Assembly Complete
444CR.....	Right Side Frog Assembly Complete
445L.....	Lifting Prongs "Left Side"
445R.....	Lifting Prongs "Right Side"
446..... (6)	Bolt & Nut 7/16" x 1 1/4"
447L.....	Left Side Plow Shear
447R.....	Right Side Plow Shear
448..... (2)	Bolt & Nut 1/2" x 1 1/4"
449.....	Frame Model 1800
450.....	Label Operating Instructions
451.....	Decal Challenger 1800
452..... (2)	Axle and Stem
459..... (2)	Side Disc Hub complete w/bolts
460.....	Plow Shear & Bolts complete
461.....	Center coulter assembly
462L.....	Left side disc complete
462R.....	Right side disc complete
463.....	Standard Shank Reset--Complete Set
463L.....	Left side complete shank assembly
463R.....	Right side complete shank assembly
464..... (2)	Depth wheel complete
490.....	1800 Serial Number Label
495..... (4)	5/8" jam nut

AUTO LIFTER PARTS LIST

ITEM #	DESCRIPTION
465	(2)..... Triangle
466.....	(4)..... Spring Rod
467.....	(4)..... Spring
468.....	(2)..... Auto Slide On
469.....	(2)..... Auto Shank
470.....	(4)..... Auto Side Plate
471.....	(2)..... Connector Bar
472.....	(2)..... Connector Bar with tension bracket
473.....	(2)..... 5/8" x 1-1/2" bolt
474.....	(4)..... 5/8" SAE Washer
475.....	(8)..... Reset Spring Washer
476.....	(4)..... 1" Nut
477.....	(6)..... 7/8" x 3 1/2" Bolt
478.....	(4)..... 7/8" SAE Washer
479.....	(6)..... 7/8" Lock Nut
480.....	(2)..... 1" Lock Nut
481.....	(2)..... 1" x 4" Bolt
482.....	(4)..... 5/8" x 3" Bolt
485L	Left side Auto Reset Slide-on Assembly
485R.....	Right side Auto Reset Slide-on Assembly



Warranty

All Rain-Flo mulch lifters have a two year warranty against defects and workmanship.

If any part is found defective, return the defective part with serial number of the machine. If Rain-Flo finds it defective, it will be replaced at no charge.

Call Customer Service at (717) 445-3000 Fax (717) 445-8304

Features

- Will lift plastics from 3 ft. to 5 ft. wide with fast and easy adjustments.
- Lifting plows uses Standard Case International 18” right and left hand “Deep-suck” Shares.
- To keep from clogging, machine has two spring loaded trash and vine cutting disks.
- Removable center disk to cut plastic in middle.
- Heavy shanks have 5/8” safety shear bolts. Auto-reset is optional.
- The Challenger is build to last and make your job easier.

Some Helpful Tips

Adjust 3-point top link to level machine.

Drive 2 to 4 MPH with plows 6” under plastic.

Adjust lifting rods 8 to 12” off the ground (must be lowered if dragging results).

Machine works best if weeds are mowed off first.

Adjust shanks approximately 2” narrower than original plastic width, (not bed top width).

After plastic is lifted, it is advisable to gather it up before any rains.

TRUBLE SHOOTING

1. **PROBLEM:** Machine does not go deep enough.

SOLUTION: Depth wheels are not set high enough.
Cutting disc are set too deep.

2. **PROBLEM:** Debris drags (plastic not flowing).

SOLUTION: Machine is not deep enough or lifting bars are set too high.

3. **PROBLEM:** Plastic mulch not flowing through lifter.

SOLUTION: Set vine cutting discs (side discs) to cut all vegetation to keep it from wrapping around the plow shank. See page 3. Discs should be in line or a little to the outside of the plow shank.

~2015 Edition~

Rain-Flo Irrigation
(717) 445-3000