

---

**MODEL 1600 SERIES II  
WATER WHEEL TRANSPLANTER**

---

**OPERATING  
MANUAL**

***Rain-Flo Irrigation***

929 Reading Road  
East Earl, Pa 17519  
PH: 717-445-3000

# Table Of Contents

Axle, Tire.....	3
Features .....	13
Foot Rest.....	4
Hand Wheel.....	4
Helpful Tips.....	14
Options .....	13
Parts Breakdown, Description .....	10-12
Parts Breakdown, Exploded Views.....	6-9
Planter Seat.....	4
Planting Wheel .....	3
Safety First .....	2
Super wheel.....	5
Third and/or Fourth Seat .....	4
Trailer Combination .....	5
Trouble Shooting .....	14
Warranty .....	13
Water Flow .....	3

# !! Safety First !!

---

- ⚠ No riders beyond the speed of 3 MPH. Be sure you read and understand all the precautions.
- ⚠ Keep people away when lifting and lowering the machine.
- ⚠ Be careful when turning around; machine is 8' long.
- ⚠ Do not crawl under the machine when lifted.
- ⚠ Do not adjust the machine when it is moving.
- ⚠ Do not stand on the machine.
- ⚠ Do not sit on machine except on designated seat.
- ⚠ Do not add chemicals to water tank unless planters wear hand protection.
- ⚠ Planter operators must keep their feet on foot rest when planting.
- ⚠ Tractor operator is responsible for extra worker(s) around machine.
- ⚠ Rain-Flo Irrigation is not responsible for accidents if any should occur.

# PLANTING WHEEL ADJUSTMENTS



**(S.S. Axle Shaft)** To hold planting wheels and plumbing.

**(Collars-2)** To hold position of plumbing valves.

**(Plumbing Valves)** To adjust water flow.

**(Water Shut-Off Handle)** To shut off water supply.

One to four planting wheels can be used at a time; standard is one or two wheels. When using only one wheel, slide plumbing to one side of wheel and keep one plumbing valve closed. Planting wheels are set in position with one bolt in center of wheel and can be moved sideways on the axle shaft.

Planting wheels will flex up and down over uneven terrain.

**Caution;** Make sure planting wheels are not puncturing drip tape underneath plastic.

---

## Tire Axle Adjustment

Tire axles need to be adjusted for high beds, and if more planting leg room is desired, shorten top link and lower tire axles.

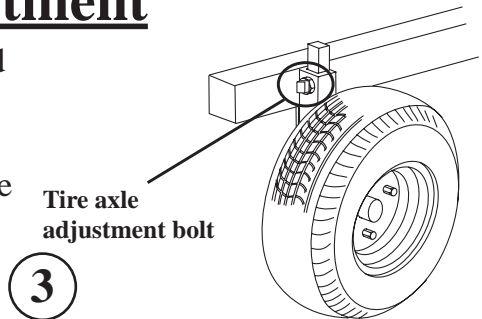

# SEAT ADJUSTMENTS

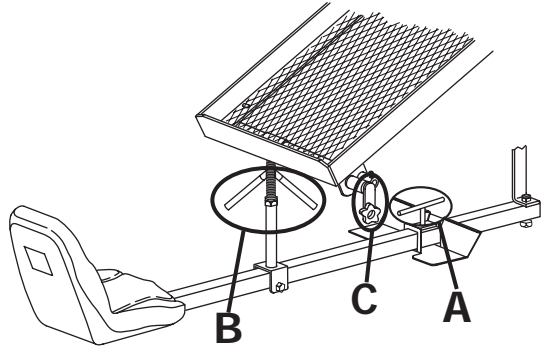

To adjust foot rest, loosen tee handle (A) and slide foot rest to desired place. Turn handles(B) to adjust seat height and handle(C) to adjust seat's "left-to-right" position for maximum comfort.

## INSTALLING 3RD AND/OR 4TH SEATS

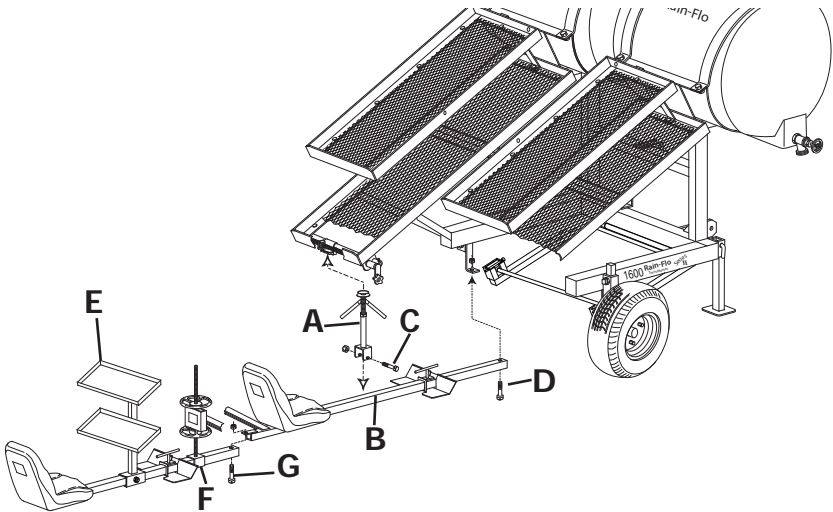

Seat with heavy bar needs to be mounted toward the front and the seat with light bar to the back. Remove 1st and 2nd seats if they are already on the planter and install the 3rd and/or 4th seats by sliding seat adjuster(A) onto seat mounting bar(B) and fasten it with bolt and nut(C). Also bolt end of seat mounting bar(B) onto frame with bolt and nut(D). Slide trays(E) and seat adjuster(F) onto 1st and 2nd seats and fasten it with bolt and nut(G) onto already installed 3rd and/or 4th seats as shown above.

# OPTIONAL SUPER WHEEL

## Removing Spike.

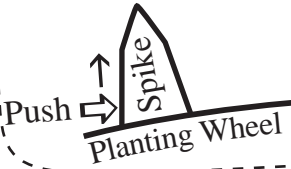

The super wheel is a very universal planting wheel. Spike size and spacing can be changed as preferred. A rubber grommet is used to close unused holes.

## Installing Spike.

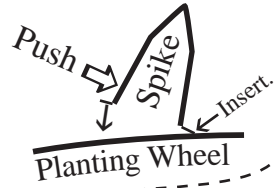

Note; lock pin is used in heavy or rocky soil conditions to avoid having spikes detaching.

## Installing lock pin.



How grommet should look when installed.



step 2.  
How to install grommet.



step 3.  
How to install grommet.  
Firmly push down.

Firmly push down.

# OPTIONAL TRAILER COMBINATION

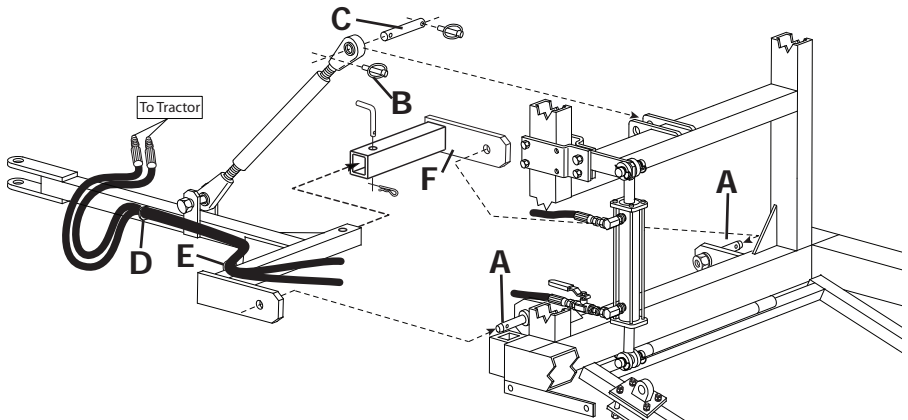

- (1) Install draw bar tongue by sliding onto the lifting pins (A).
- (2) Unsnap lynch pins (B), remove top link pin (C) and install as shown above.
- (3) Slide hydraulic hoses through loops (D) and (E).
- (4) Slide hitch bracket (F) onto lifting pin and over hitch tubing. Insert pin.

Figure 1

1600

**#340B**

Optional: 3rd or 4th Seat  
(#340A - 343A, 345,  
346, 387, 24, 27, 120)

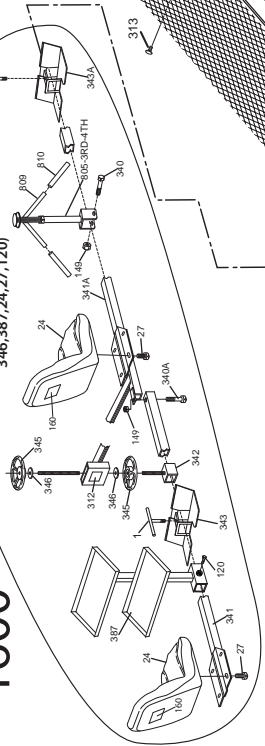

B  
See Figure 4

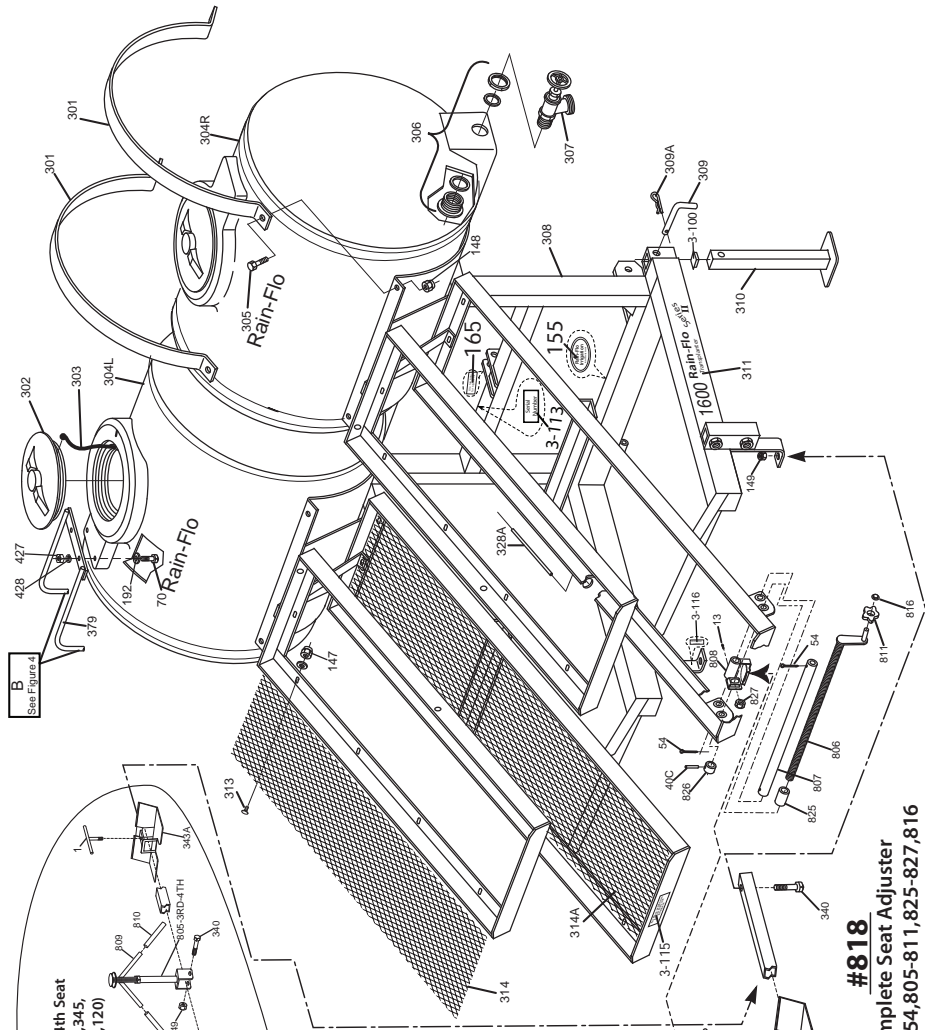

**#348C**

Plantering Seat Complete  
24, 27, 149, 340, 341, 343

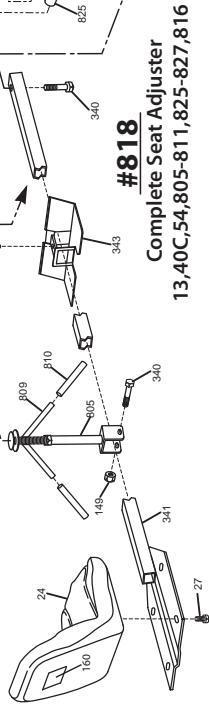

**#818**  
Complete Seat Adjuster  
13, 40C, 54, 805-811, 825-827, 816





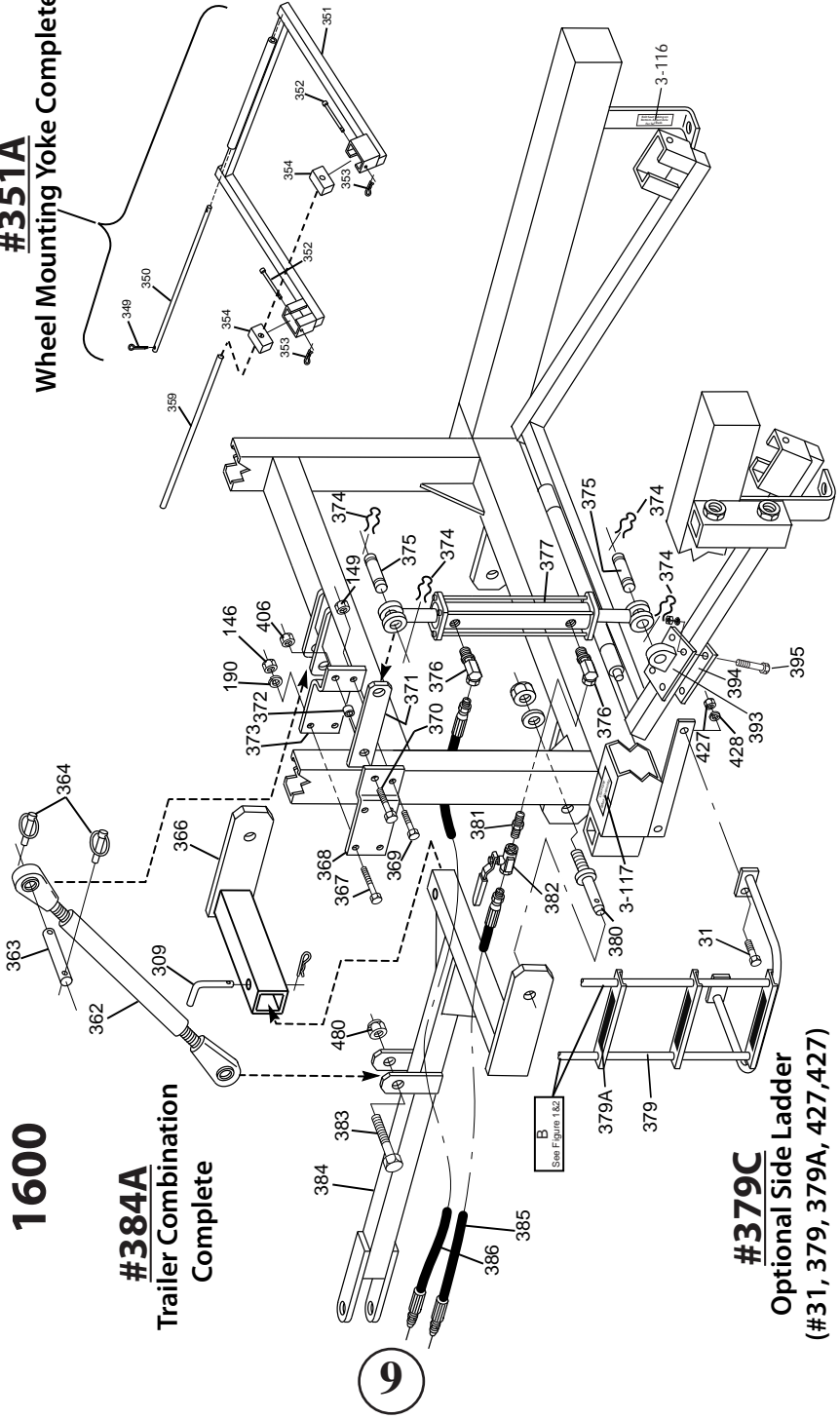

Figure 4

1600

**#384A**  
Trailer Combination  
Complete

**#351A**  
Wheel Mounting Yoke Complete



**#379C**  
Optional Side Ladder  
(#31, 379, 379A, 427, 427)

# *Model 1600 Series II Transplanter*

<b>ITEM #</b>	<b>DESCRIPTION</b>
1.....(2).....	Tee handle
5.....(2).....	3/8" x 3/4" sq. head lock bolt
13.....(2).....	1/4" NFT straight grease zert
24.....(2).....	Cushion seat
27.....(8).....	5/16" x 1/2" seat bolt
31.....(6).....	3/8" x 1" bolt
40C.....(2).....	1/4" x 1" roll pin
54.....(6).....	1/8" cotter pin
70.....(3).....	3/8" x 1 1/4" bolt
120.....	1/2" x 1 1/2" bolt
146.....(4).....	1/2" hex nut
147.....(50).....	1/4" nylon lock nut
148.....(9).....	3/8" nylon lock nut
149.....(5).....	1/2" nylon lock nut
155.....	Rain-Flo oval logo
160.....(2).....	Important notice label on seat
165.....	Use top hole for higher lift label
190.....(4).....	1/2" locking washer
192.....(2).....	3/8" flat washer
301.....(4).....	Saddle band
302.....(2).....	Tank lid
303.....(2).....	Rubber lid holder
304L.....	80 Gal. Rain-Flo tank with tank adapter
304R.....	80 Gal. Rain-Flo tank with valve in end
305.....	3/8" x 2 1/4" bolt
306.....	3/4" tank adapter
307.....	3/4" drain valve
308.....	Frame
309.....(2).....	Removal pin
309A.....(2).....	Removal safety pin
310.....(2).....	Support stand
311.....(2).....	Model No. label
312.....	Seat adjusting labels
313.....(50).....	1/4" x 3/4" elevator bolt
314.....(2).....	Top expanded metal
314A.....(2).....	Bottom expanded metal
316.....(2).....	2" tank adapter
317.....(2).....	2" insert male adapter
318.....(5).....	2" hose clamps
319.....(2).....	2" hose extension
320.....	2" x 2" x 1" tee
321.....(2).....	1" hose clamps
322.....	1" x 5" hose extension
323A.....	1" insert x female ell
324R.....	1" Planter Valve, [New Style For Cable Pull]
325.....	1/16" x 3/4" cotter pin
326.....	Weld-on male adapter
327.....	1" x 3/4" hose extension
327 A.....	3rd and 4th wheel plumbing
328A.....	On-off valve cable
328B.....	Cable adjustment turn buckle

# Model 1600 Series II Transplanter

ITEM #	DESCRIPTION
328C.....	Complete valve assembly
328D.....	Valve spring
328H.....	Water shut off handle
330.....(2).....	Adjusting axle stem
331.....(2).....	Seal
332.....(4).....	Tapered bearing
333.....(2).....	Metal hub
334.....(2).....	SAE washer
335.....(2).....	Cotter pin
336.....(2).....	Fine thread lock nut
337.....(2).....	Cap
338.....(2).....	20.5 x 8.0 - 10 tire wheel
339.....(10).....	Lug bolt
340.....(4).....	½" x 3½" bolt
340A.....	½" x 4" bolt
340B.....	Optional 3rd or 4th seat complete w/ tray
341.....(2).....	Seat mounting bar
341A.....	Optional 3rd or 4th seat bracket only
342.....	Seat adjustment mounting
343.....(2).....	Foot rest
343A.....	Foot rest for 3rd or 4th seat
345.....(2).....	Height adjusting wheel
346.....(2).....	Custom washer
348C.....	Cushion seat and bar complete
350.....	Yoke hinge pin
351.....	Wheel mounting yoke
351A.....	Wheel mounting yoke complete
352.....(2).....	Bushing locking pin
353.....(2).....	Safety pin
354.....(2).....	UHMW block bushing
355.....	Planting wheel (specify spacing & spike)
356.....(2).....	Plumbing collar
358.....	Snap pin
359.....	1" x 45¼" S.S. shaft
360.....	3/8" x 1" sq. head lock bolt
361.....	Two valve plumbing assembly
361A.....	Two valve plumbing tee adapter only
362.....	Top link
363.....	Top link pin
364.....(2).....	Lynch pin
366.....	Tongue bracket
367.....(4).....	½" x 4¾" bolt
368.....	Cylinder mount, left side (from back)
369.....	½" x 2¾" bolt
370.....	¾" x 3" bolt
371.....	Cylinder hinge plate
372.....(2).....	Hinge plate spacer
373.....	Cylinder mount, right side (from back)
374.....(4).....	Cylinder snap pin
375.....(2).....	Cylinder attach pin
376.....(2).....	Flow restricted fitting

# *Model 1600 Series II Transplanter*

<b>ITEM #</b>	<b>DESCRIPTION</b>
377.....	Hydraulic cylinder
379.....	Ladder
379A.....(3).....	Ladder step traction tape
379C.....	Side Ladder Complete
380.....(2).....	Cat II lift pin
381.....	3/8" nipple
382.....	3/8" Hyd. ball valve
383.....	1" x 5" bolt
384.....	Draw bar tongue
384A.....	Trailer combination complete
385.....	3/8" x 8' 3" Hyd. hose
386.....	3/8" x 8' 10" Hyd. hose
387.....	3rd and 4th seat top tray
388.....(2).....	Hub complete
389.....(2).....	Tire assembly complete
390.....	Top tray complete (with brackets)
390A.....	Top tray bracket only
391.....	Weld-on wheel spikes
392.....	Snap-on wheel spikes
393.....	Cylinder yoke bracket
394.....(4).....	Cylinder yoke bracket plate
396.....(2).....	Top tray front bolt-on plate
397.....(2).....	Top tray bolt-on plate
398.....	Expanded metal
406.....	3/4" lock nut
418.....(4).....	5/8" x 1½" set screw
427.....(10).....	3/8" nut
428.....(10).....	3/8" lock nut
480.....	1" lock nut
3-100.....(2).....	Rubber stand cap
3-101.....	Water shut off handle rubber grip
3-113.....	Serial number label
3-115.....(2).....	For more leg room label
3-116.....(2).....	Bolt seat tubing on bottom label
3-117.....	Close valve when transporting label
805.....(2).....	Seat adjuster bottom tube assembly
805-3rd-4th.....	Seat adjuster bottom tube assembly for 3rd/4th seat
806.....(2).....	Threaded rod with hand crank
807.....(2).....	Seat adjustment 1" rod
808.....(2).....	Seat adjustment hanger
809.....(2).....	Seat adjuster upright threaded rod
810.....(4).....	Seat adjuster handle rubber grip
811.....(2).....	Seat adjuster side knob
816.....(2).....	Seat adjuster side knob cap
818.....	Seat adjuster complete
826.....(2).....	Adjuster threaded rod collar w/roll pin
827.....(2).....	3/4" x 6" Acme thread nut
842.....(3).....	3/4" male adp MPT x Insert
843.....(2).....	3/4" brass gate valve
844.....(2).....	3/4" short YB nipple

# Features

- Capability of 8” to 36” row spacing and one to four planting wheels. (Standard)
- Four slant galvanized expanded metal trays.
- Specialty designed tanks so tractor operator can see people planting, making it easier to communicate.
- More Water Capacity, Two 80 gallon tanks. (Total 160 gallons)
- Quick change water wheel setup.
- Easy seat adjustment for comfort and foot rest adjustment.
- Large tires with highway bearings.
- Will plant minimum 60” row centers.
- Side valve for washing hands.
- Quality powder coated baked-on paint.

# Options

- \* Optional super wheel (spike changes to many sizes and spacings)
- \* Optional side ladder
- \* Optional top tray
- \* Optional 3 and 4 seat with trays
- \* Optional trailer\3-point combination

# Warranty

All Rain-Flo Water Wheel Transplanters have a two year warranty against defects in material and workmanship.

If any part found defective, return the defective part with Serial No. of the machine. If Rain-Flo finds it defective, it will be replaced or repaired at no charge.

Call Customer Service at (717) 445-3000. Fax (717) 445-8304

# Some Helpful Tips

---

For best crop stand, planting operators should firmly press plants into water-filled hole. If plenty of water is used, potted plants will be sealed and do not need to be covered with soil.

When using starter fertilizer, it needs to be agitated. Fertilizer is heavier than water and will settle to the bottom of the tank, resulting in possibly burning or killing the first couple hundred plants.

For faster planting, operators may put one tray of plants on their lap.

If soil is very sandy and does not paste on planting wheel, this machine can also be used on bare soil.

## TROUBLESHOOTING

---

**1. PROBLEM:** Planter is used on bare soil, and soil tends to paste onto planting wheel.

**SOLUTION:** Soil is too wet or wheel needs to be cleaned or repainted.

**2. PROBLEM:** Not enough leg room.

**SOLUTION:** Adjust foot rest. See page 4.  
Adjust top link and axle. See page 3.

**3. PROBLEM:** Tractor can't lift planter.

**SOLUTION:** Optional trailer hitch available. See pages 5 & 9  
Keep less water in tanks.

**~2015 Edition~**

**Rain-Flo Irrigation  
(717) 445-3000**